

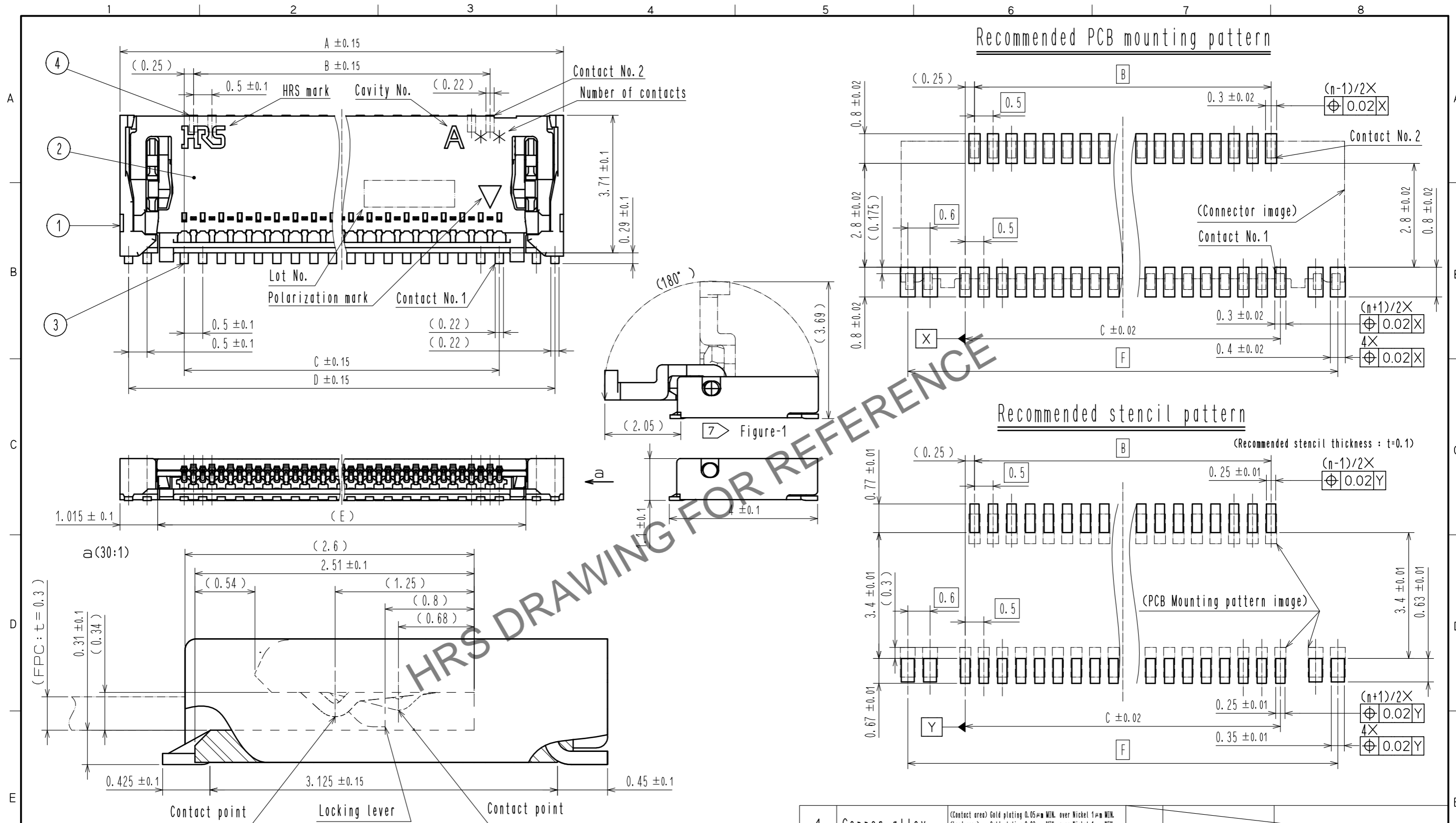

**THE DATASHEET OF
FH62-35S-0.25SHW(10)**



Jun.1.2024 Copyright 2024 HIROSE ELECTRIC CO., LTD. All Rights Reserved.
In case of consideration for using Automotive equipment / device which demand high reliability, kindly contact our sales window correspondents.



NOTES

- The dimension in parentheses are for reference.
- Lead co-planarity including reinforced metal fittings shall be 0.1 max.
- To be delivered with tape and reel packages.
See attached packaging specifications for details.
- Note that preventive hole for sink mark or slit could be added for improvement.
- The quality remains good, even with the dark spots, which could occasionally occur on molded plastic.
- This product satisfies halogen free requirements defined as 900ppm maximum chlorine, 900ppm maximum bromine, and 1500ppm maximum total of chlorine and bromine.
- Figure-1 is in state that opened the locking lever. After flip up the locking lever over 45 degrees withdraw the FPC.
8. 'n' represents the number of contacts.

4	Copper alloy	(Contact area) Gold plating 0.05μm MIN. over Nickel 1μm MIN. (Lead area) Gold plating 0.03μm MIN. over Nickel 1μm MIN. (Other) Nickel plating 1μm MIN.			
3	Copper alloy	(Contact area) Gold plating 0.05μm MIN. over Nickel 1μm MIN. (Lead area) Gold plating 0.03μm MIN. over Nickel 1μm MIN. (Other) Nickel plating 1μm MIN.	8	(Connector)	
2	PA	BLACK UL94V-0	6	Polyester	
1	LCP	BEIGE UL94V-0	5	Polystyrene	
NO.	MATERIAL	FINISH . REMARKS	NO.	MATERIAL	FINISH . REMARKS
UNITS mm		SCALE 10 : 1	COUNT 19	DESCRIPTION OF REVISIONS DIS-F-00016208	DESIGNED SE. YOKOYAMA
					CHECKED HS. HIRAHARA
					DATE 20221213
	HIROSE ELECTRIC CO., LTD.	APPROVED : NF. MIYAZAKI 20170404	DRAWING NO. EDC-368163-10-01		
		CHECKED : YN. TAKASHITA 20170404	PART NO. FH62-**S-0.25SHW(10)		
		DESIGNED : HH. MURAKAMI 20170404	CODE NO. CL580		
		DRAWN : HH. MURAKAMI 20170404	1/9		

Jun.1.2024 Copyright 2024 HIROSE ELECTRIC CO., LTD. All Rights Reserved.
 In case of consideration for using Automotive equipment / device which demand high reliability, kindly contact our sales window correspondents.

Embossed carrier tape dimension (2:1)

■ TAPE WIDTH : 24mm MAX

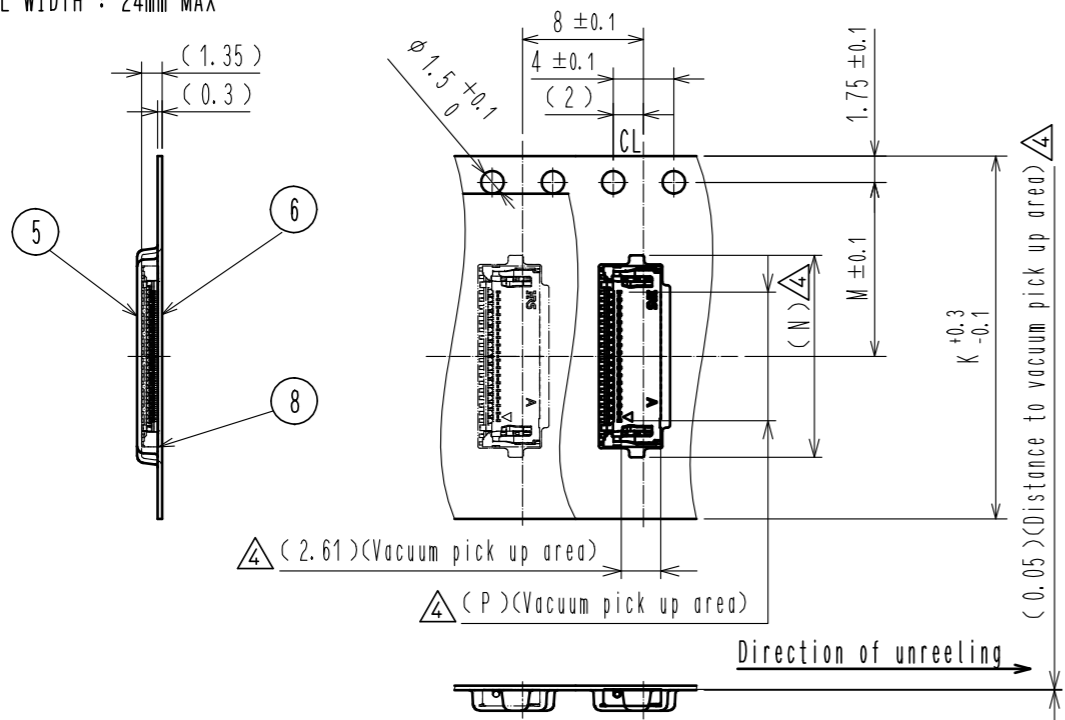

■ TAPE WIDTH : 32mm MIN

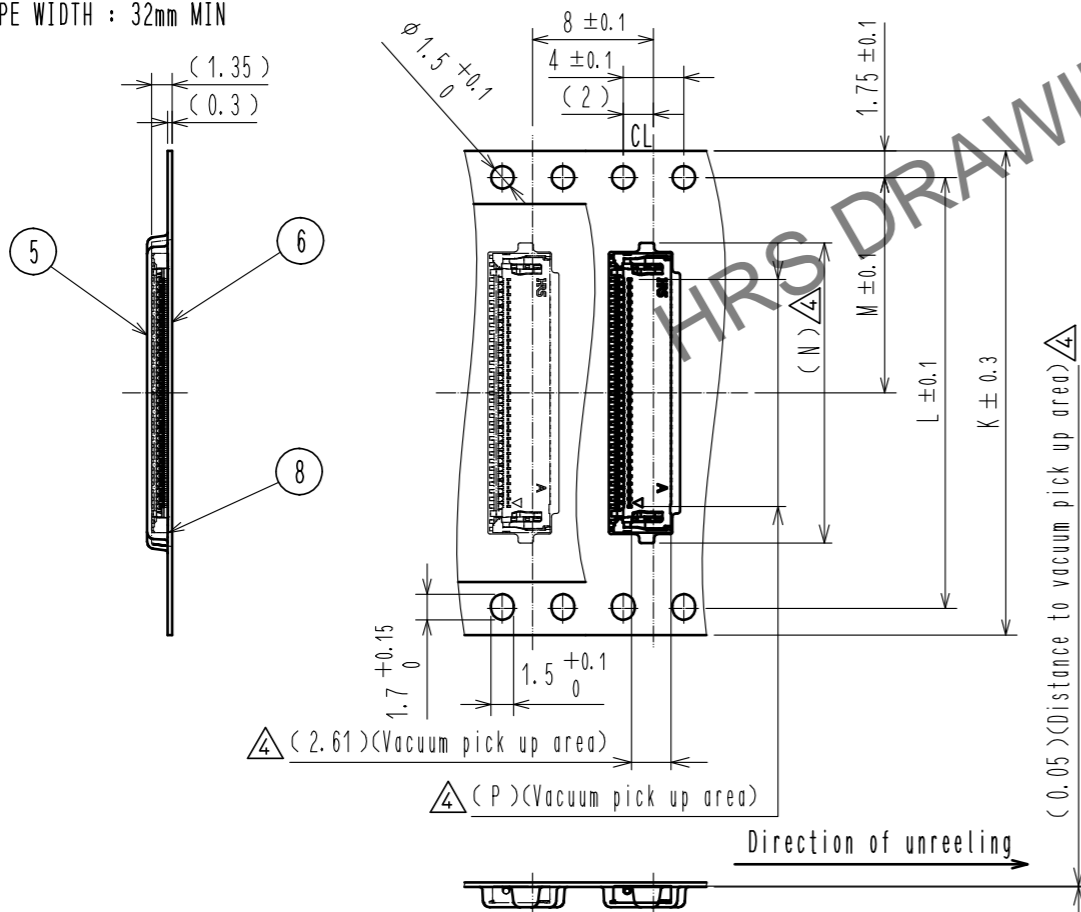

Reel dimension (FREE)

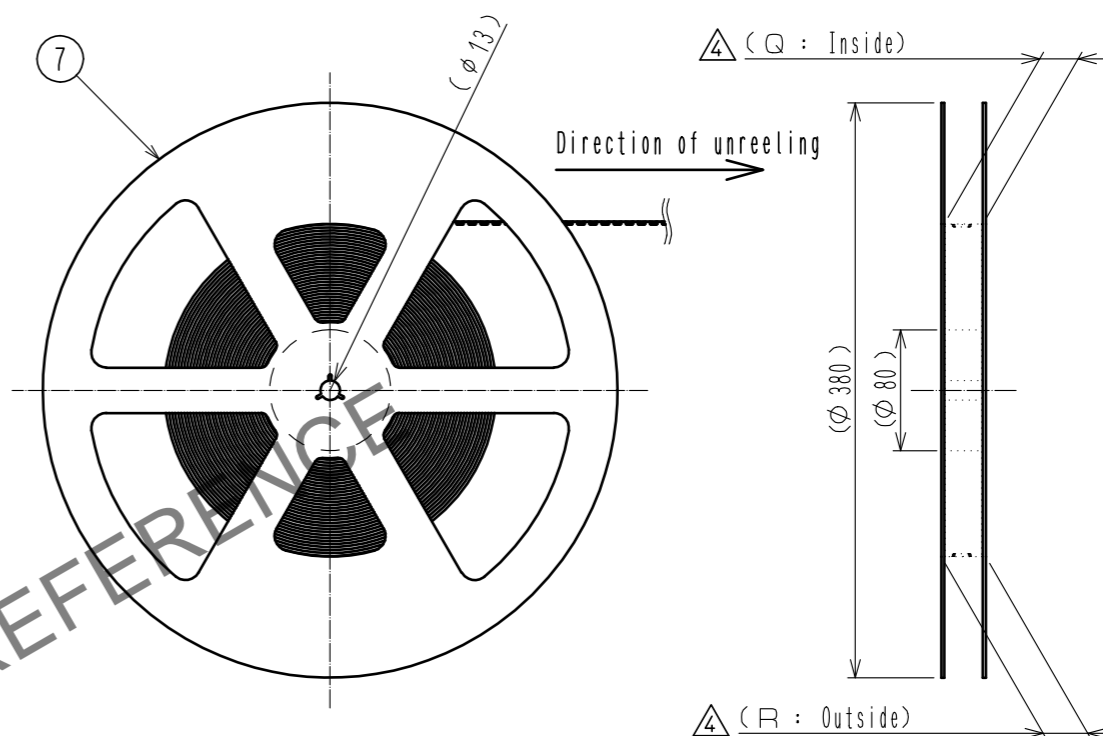

Leader, Trailer dimension (FREE)

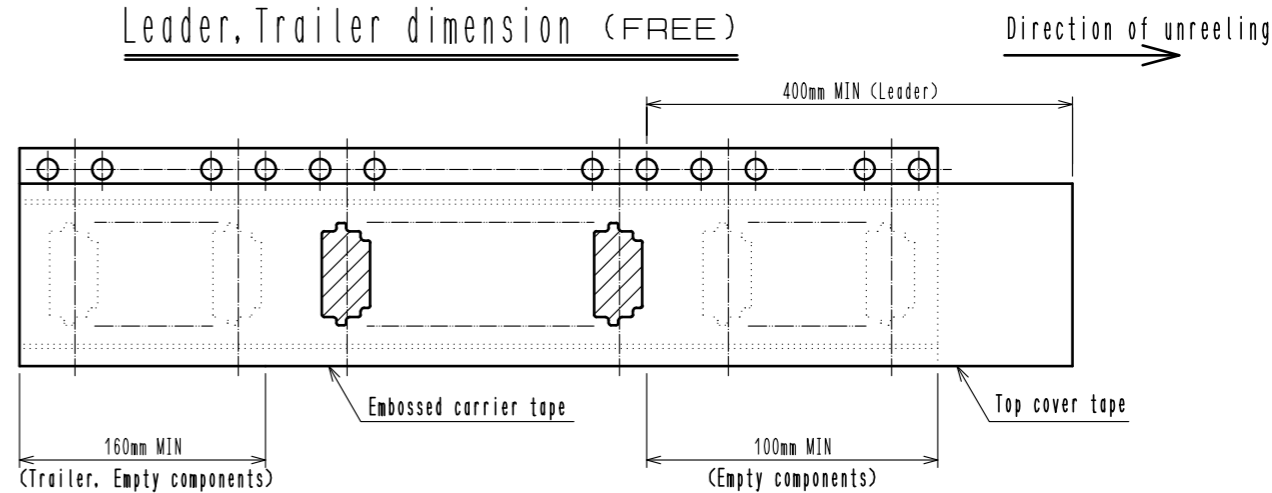

NOTES 14. Per reel : 5000 connectors.
 15. Refer to JIS C 0806 and IEC60286-3.
 (Packaging of components for automatic handling.)

<Packing specification>

HRS	DRAWING NO.	EDC-368163-10-01
	PART NO.	FH62-**S-0.25SHW(10)
	CODE NO.	CL580
		△ 3/9

Jun.1.2024 Copyright 2024 HIROSE ELECTRIC CO., LTD. All Rights Reserved.
In case of consideration for using Automotive equipment / device which demand high reliability, kindly contact our sales window correspondents.

Part Number	Code Number	Number of Contacts	Dimension of connector, PCB mounting pattern, metal mask, FPC										Dimension of drawing for packing					
			A	B	C	D	E	F	G	H	J	K	L	M	N	P	Q	R
FH62-11S-0.25SHW(10)		11	5.96	2	2.5	5.5	3.93	5.6	3.9	5.1	3.3	16	-	7.5	7.36	2.5	17.4	21.4
FH62-13S-0.25SHW(10)	CL0580-4308-0-10	13	6.46	2.5	3	6	4.43	6.1	4.4	5.6	3.8	16	-	7.5	7.86	3	17.4	21.4
FH62-15S-0.25SHW(10)		15	6.96	3	3.5	6.5	4.93	6.6	4.9	6.1	4.3	24	-	11.5	8.36	3.5	25.4	29.4
FH62-17S-0.25SHW(10)	CL0580-4303-0-10	17	7.46	3.5	4	7	5.43	7.1	5.4	6.6	4.8	24	-	11.5	8.86	4	25.4	29.4
FH62-19S-0.25SHW(10)		19	7.96	4	4.5	7.5	5.93	7.6	5.9	7.1	5.3	24	-	11.5	9.36	4.5	25.4	29.4
FH62-21S-0.25SHW(10)	CL0580-4312-0-10	21	8.46	4.5	5	8	6.43	8.1	6.4	7.6	5.8	24	-	11.5	9.86	5	25.4	29.4
FH62-23S-0.25SHW(10)		23	8.96	5	5.5	8.5	6.93	8.6	6.9	8.1	6.3	24	-	11.5	10.36	5.5	25.4	29.4
FH62-25S-0.25SHW(10)		25	9.46	5.5	6	9	7.43	9.1	7.4	8.6	6.8	24	-	11.5	10.86	6	25.4	29.4
FH62-27S-0.25SHW(10)		27	9.96	6	6.5	9.5	7.93	9.6	7.9	9.1	7.3	24	-	11.5	11.36	6.5	25.4	29.4
FH62-29S-0.25SHW(10)		29	10.46	6.5	7	10	8.43	10.1	8.4	9.6	7.8	24	-	11.5	11.86	7	25.4	29.4
FH62-31S-0.25SHW(10)	CL0580-4310-0-10	31	10.96	7	7.5	10.5	8.93	10.6	8.9	10.1	8.3	24	-	11.5	12.36	7.5	25.4	29.4
FH62-33S-0.25SHW(10)		33	11.46	7.5	8	11	9.43	11.1	9.4	10.6	8.8	24	-	11.5	12.86	8	25.4	29.4
FH62-35S-0.25SHW(10)	CL0580-4300-5-10	35	11.96	8	8.5	11.5	9.93	11.6	9.9	11.1	9.3	24	-	11.5	13.36	8.5	25.4	29.4
FH62-37S-0.25SHW(10)		37	12.46	8.5	9	12	10.43	12.1	10.4	11.6	9.8	24	-	11.5	13.86	9	25.4	29.4
FH62-39S-0.25SHW(10)	CL0580-4302-0-10	39	12.96	9	9.5	12.5	10.93	12.6	10.9	12.1	10.3	24	-	11.5	14.36	9.5	25.4	29.4
FH62-41S-0.25SHW(10)	CL0580-4305-0-10	41	13.46	9.5	10	13	11.43	13.1	11.4	12.6	10.8	24	-	11.5	14.86	10	25.4	29.4
FH62-43S-0.25SHW(10)		43	13.96	10	10.5	13.5	11.93	13.6	11.9	13.1	11.3	24	-	11.5	15.36	10.5	25.4	29.4
FH62-45S-0.25SHW(10)		45	14.46	10.5	11	14	12.43	14.1	12.4	13.6	11.8	24	-	11.5	15.86	11	25.4	29.4
FH62-47S-0.25SHW(10)		47	14.96	11	11.5	14.5	12.93	14.6	12.9	14.1	12.3	32	28.4	14.2	16.36	11.5	33.4	37.4
FH62-49S-0.25SHW(10)		49	15.46	11.5	12	15	13.43	15.1	13.4	14.6	12.8	32	28.4	14.2	16.86	12	33.4	37.4
FH62-51S-0.25SHW(10)		51	15.96	12	12.5	15.5	13.93	15.6	13.9	15.1	13.3	32	28.4	14.2	17.36	12.5	33.4	37.4
FH62-53S-0.25SHW(10)		53	16.46	12.5	13	16	14.43	16.1	14.4	15.6	13.8	32	28.4	14.2	17.86	13	33.4	37.4
FH62-55S-0.25SHW(10)	CL0580-4309-0-10	55	16.96	13	13.5	16.5	14.93	16.6	14.9	16.1	14.3	32	28.4	14.2	18.36	13.5	33.4	37.4
FH62-57S-0.25SHW(10)		57	17.46	13.5	14	17	15.43	17.1	15.4	16.6	14.8	32	28.4	14.2	18.86	14	33.4	37.4
FH62-59S-0.25SHW(10)		59	17.96	14	14.5	17.5	15.93	17.6	15.9	17.1	15.3	32	28.4	14.2	19.36	14.5	33.4	37.4
FH62-61S-0.25SHW(10)	CL0580-4306-0-10	61	18.46	14.5	15	18	16.43	18.1	16.4	17.6	15.8	32	28.4	14.2	19.86	15	33.4	37.4

※The products without code number are currently under planning.
Please contact HIROSE for detailed information about product variation.

<Dimension table>

HRS	DRAWING NO.	EDC-368163-10-01
	PART NO.	FH62-**-0.25SHW(10)
	CODE NO.	CL580

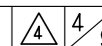

Jun.1.2024 Copyright 2024 HIROSE ELECTRIC CO., LTD. All Rights Reserved.
In case of consideration for using Automotive equipment / device which demand high reliability, kindly contact our sales window correspondents.

This connector features small and thin, requiring delicate and careful handling.
To prevent connector/FPC breakage and contact failure (mating failure, FPC pattern breakage, etc),
read through the instructions shown below and handle the connector properly.

[Connector Part Nomenclature]

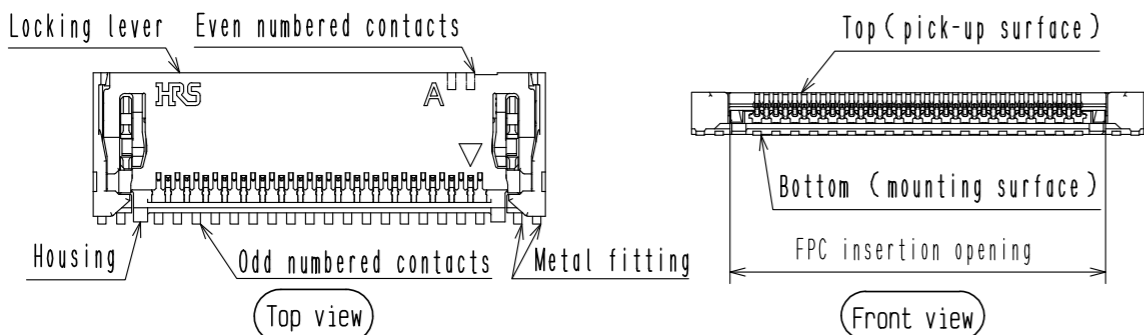

[Operation and precautions]

1. Initial condition

The product is supplied with the lock lever closed.
Locking lever does not have to be operated before inserting FPC.

[Caution]

- Do not open the locking lever when the FPC is not inserted.
The lock lever is to be used only when extracting the FPC (Example 1).
- Do not insert FPC or operate locking lever before mounting (Example 1).

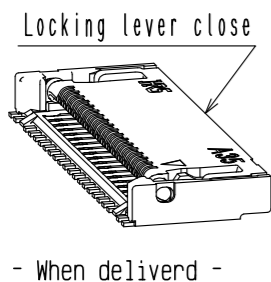

- When delivered -

Example 1)

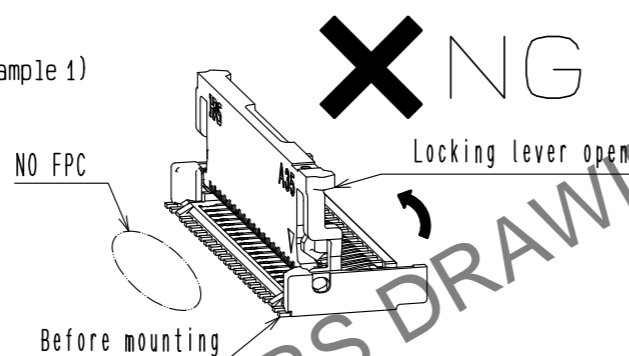

2. How to insert FPC

Insert the FPC into the connector opening horizontally to the PCB surface (Example 2).
Insert it properly to the very end.

[Caution]

- Make sure the lock lever is closed when inserting the FPC.
Do not insert the FPC when the lock lever is open (Example 3).
- Align both sides of FPC horizontally to the sides of the connector opening and insert straightforward.
- Do not twist the FPC to up and down or right and left or an angle (Example 4, 5).

Example 2)

FPC (Horizontal state)

Locking lever close

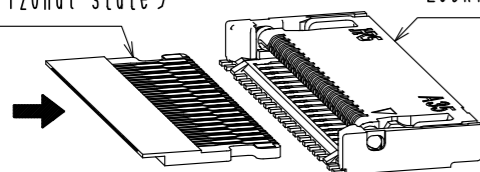

Locking lever close
FPC (Horizontal state)

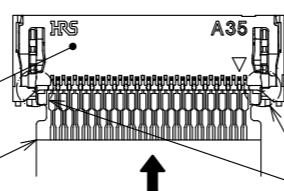

Align both sides of FPC horizontally to the sides of the connector opening and insert straightforward.

Example 3)

NG

Locking lever open

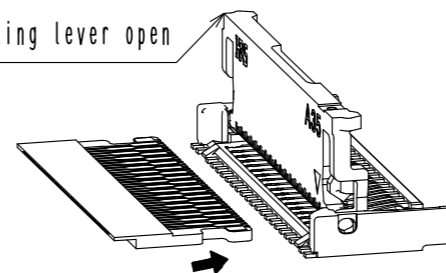

Example 4)

NG

Locking lever close

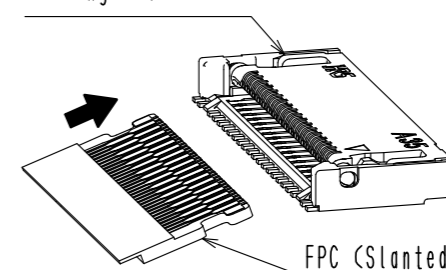

Example 5)

NG

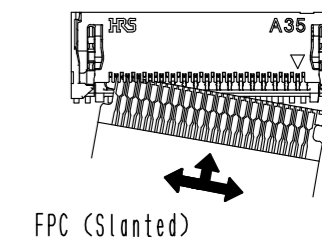

3. FPC insertion check

Make sure that the FPC is completely inserted to the end after FPC insertion (Example 6).
(The FPC position is to be aligned by the protrusion of the locking lever.)

[Caution]

- Do not insert the FPC at an angle and/or stop it before insertion is completed (Example 7, 8).
- As this product is designed for one action locking, the locking lever does not have to be operated after inserting FPC.

Example 6)

OK

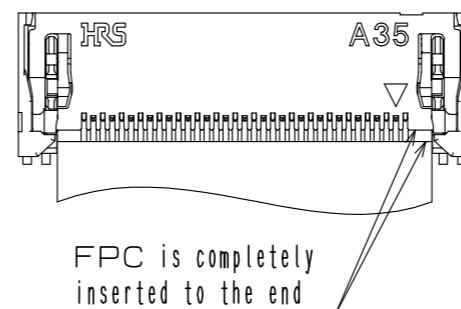

FPC is completely inserted to the end

Section - locking area -

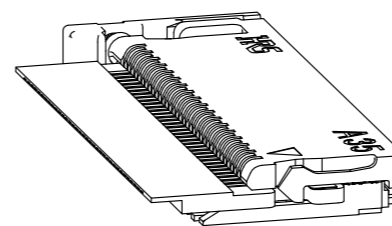

Example 7)

NG

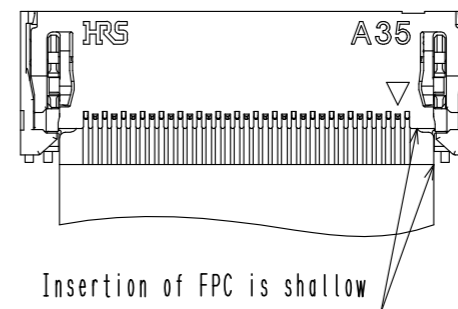

Insertion of FPC is shallow

Section - locking area -

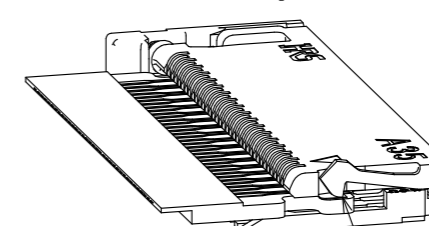

Locking Lever run on the FPC.

Example 8)

NG

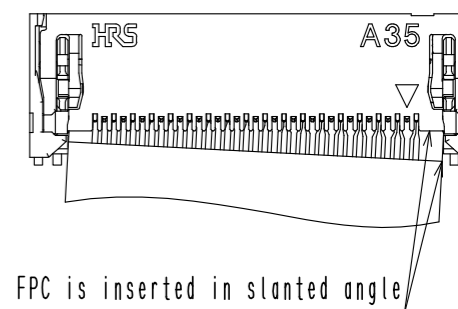

FPC is inserted in slanted angle

Section - locking area -

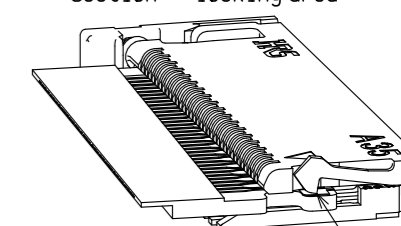

Locking Lever run on the FPC.

<Instruction manual(1)>

HRS

DRAWING NO.	EDC-368163-10-01
PART NO.	FH62-**-S-0.25SHW<10>
CODE NO.	CL580

4/5

Jun.1.2024 Copyright 2024 HIROSE ELECTRIC CO., LTD. All Rights Reserved.
In case of consideration for using Automotive equipment / device which demand high reliability, kindly contact our sales window correspondents.

4. How to release the lock

Slowly flip up the locking lever to release the lock (Example 9).

[Caution]

- To open the locking lever, operate at the center of the locking lever (Example 10).
- To open the locking lever, do not operate the locking lever at one end only (Example 11).
- The locking lever is opened up to the movable limit, 180 degree. Do not open the locking lever beyond the specified degree or apply excess force to the locking lever (Example 12).
- Do not touch contacts after the locking lever is opened (Example 13).
- Do not pick the locking lever to lift and pull it (Example 14).
- Operate the locking lever by hand without using sharp tool such as Tweezers. (Example 15).
- Do not apply excess force to the housing during the operation (Example 16).
- Do not try to open the lock lever from the FPC insertion side, as the lock lever is designed with the opposite direction from the FPC insertion direction (Example 17).

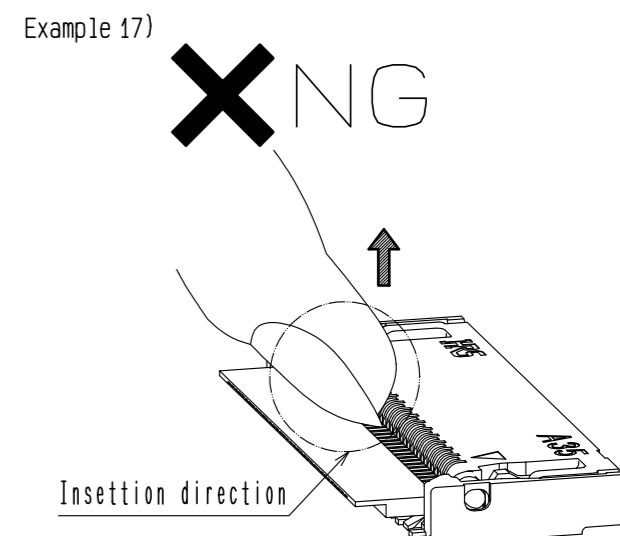
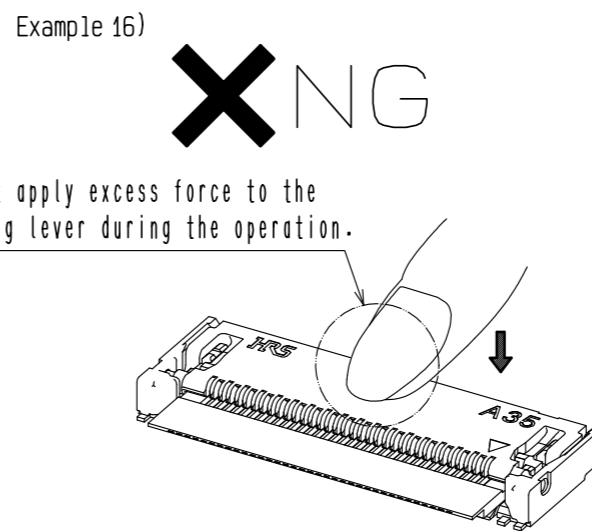
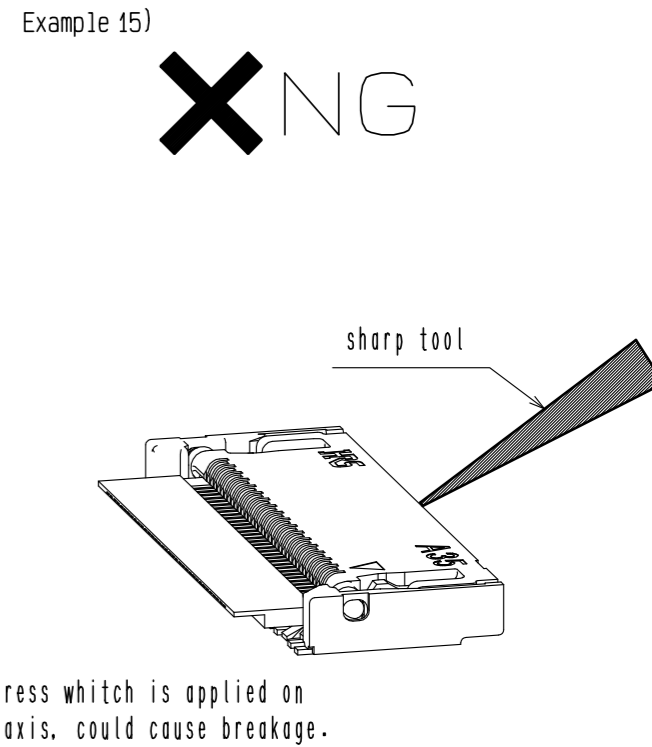
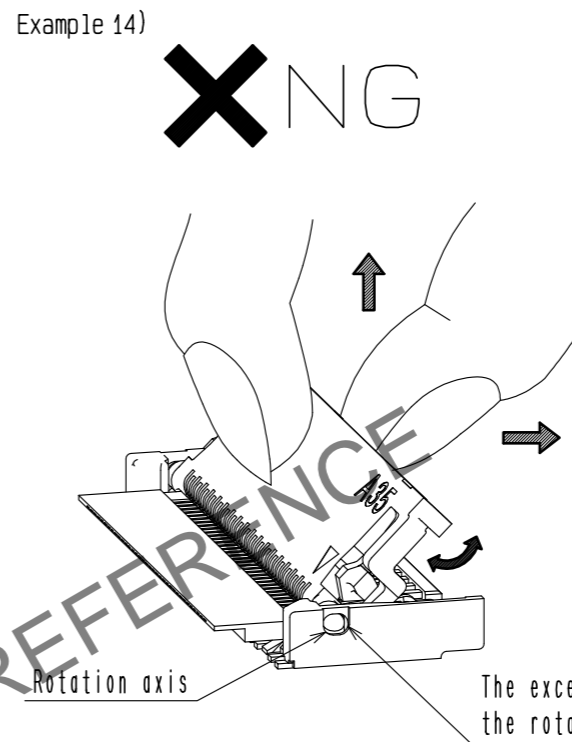
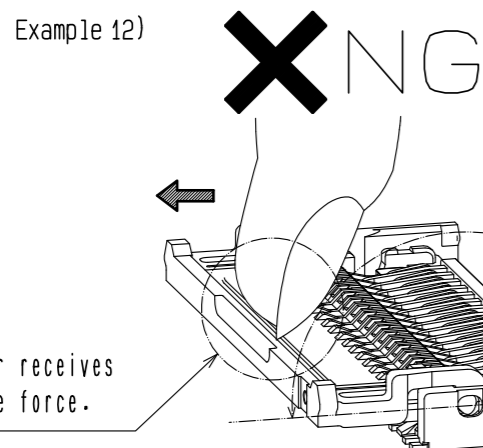
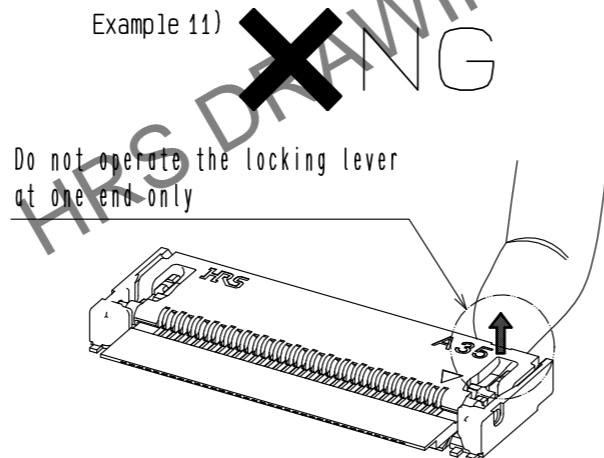
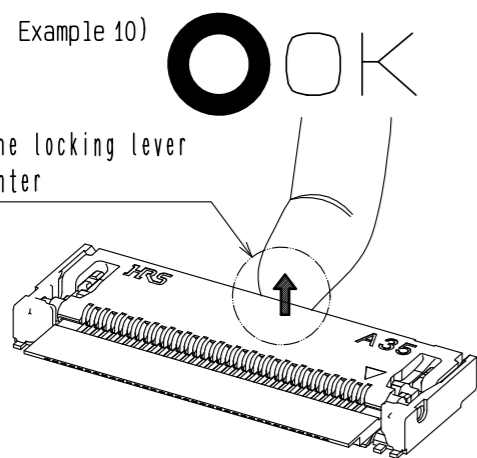
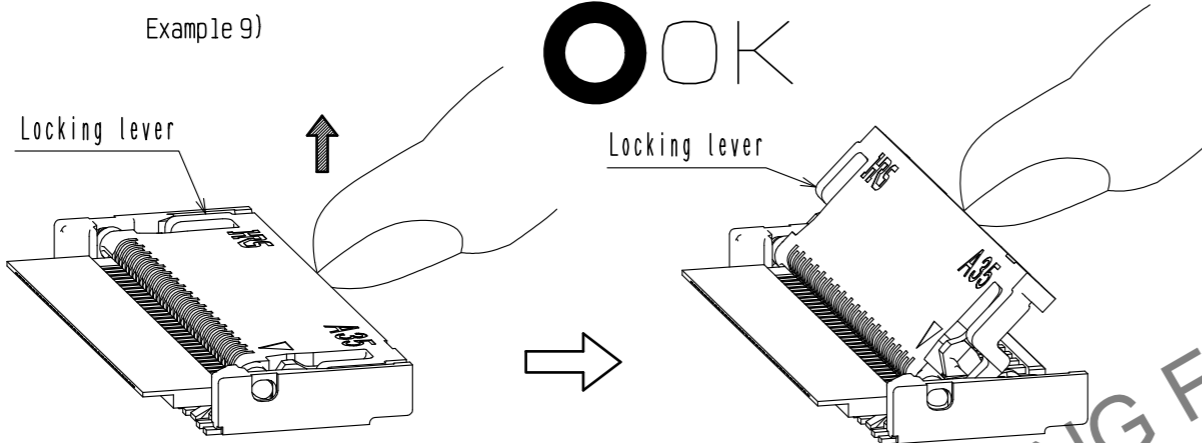

<Instruction manual(2)>

HRS	DRAWING NO.	EDC-368163-10-01
	PART NO.	FH62-**S-0.25SHW<10>
	CODE NO.	CL580
		4/6/9

Jun.1.2024 Copyright 2024 HIROSE ELECTRIC CO., LTD. All Rights Reserved.
In case of consideration for using Automotive equipment / device which demand high reliability, kindly contact our sales window correspondents.

5. How to remove FPC

After flip up the locking lever more than 45 degrees carefully withdraw the FPC (Example 18).
Close the locking lever after withdraw the FPC (Example 19).

[Caution]

- Do not attempt to pull the FPC when the locking lever is less than 45 degrees (Example 20).
- This connector has a temporary FPC holding structure with the locking lever.
For FPC removal, do not pull out the FPC upward or angled direction (Example 21).
- Close the both ends of the locking lever (Example 22).

Example 18)

OK

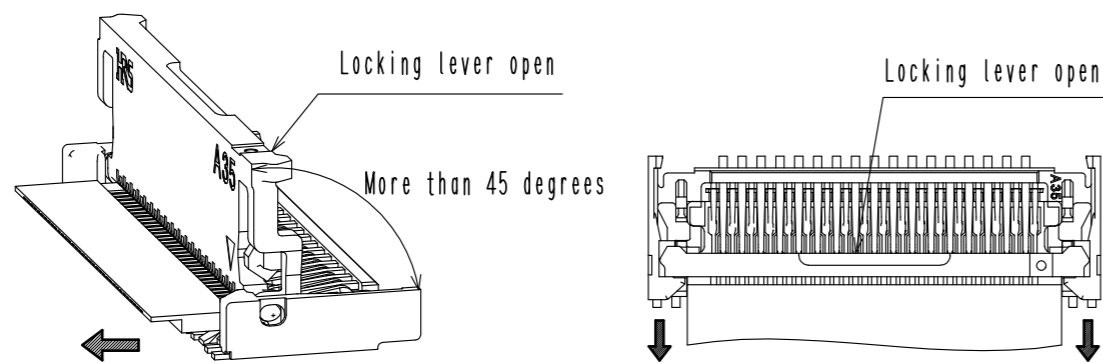

Example 19)

OK

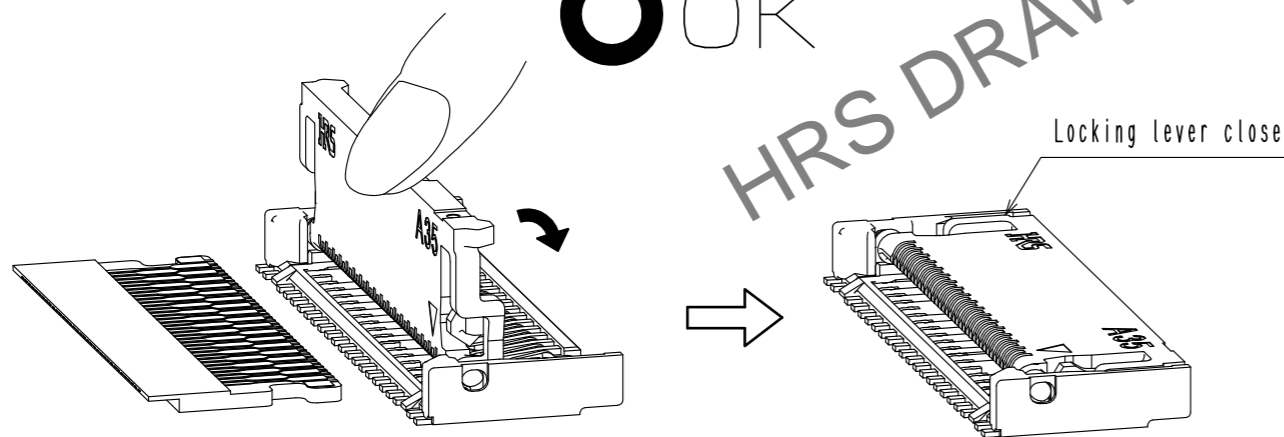

Example 20)

Section - locking area -

OK

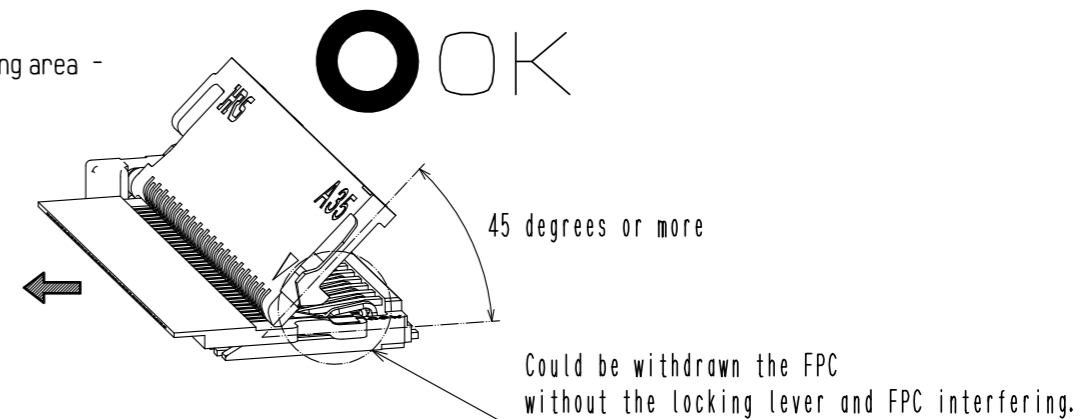

Locking lever close

NG

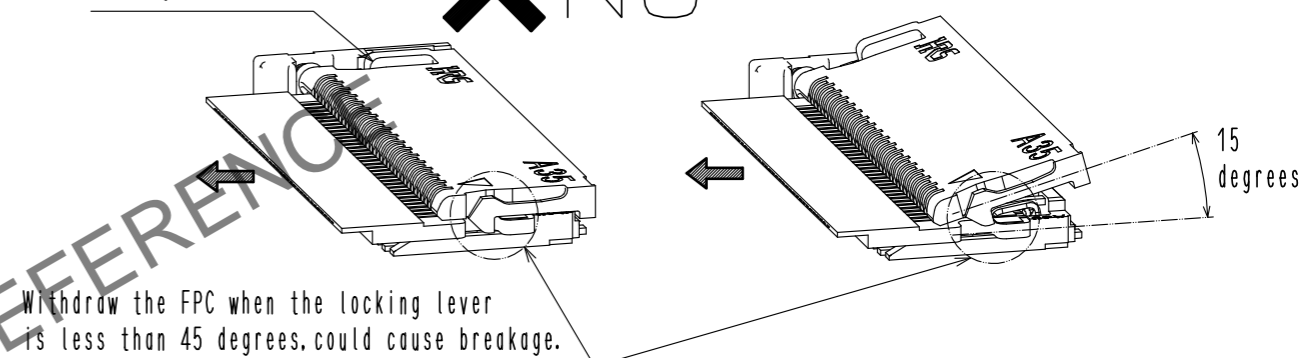

Example 21)

NG

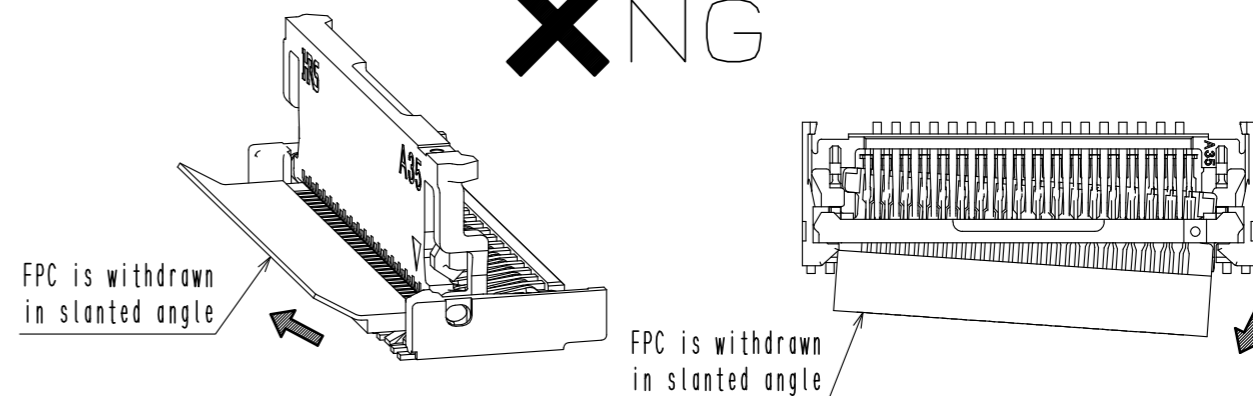

Example 22)

OK

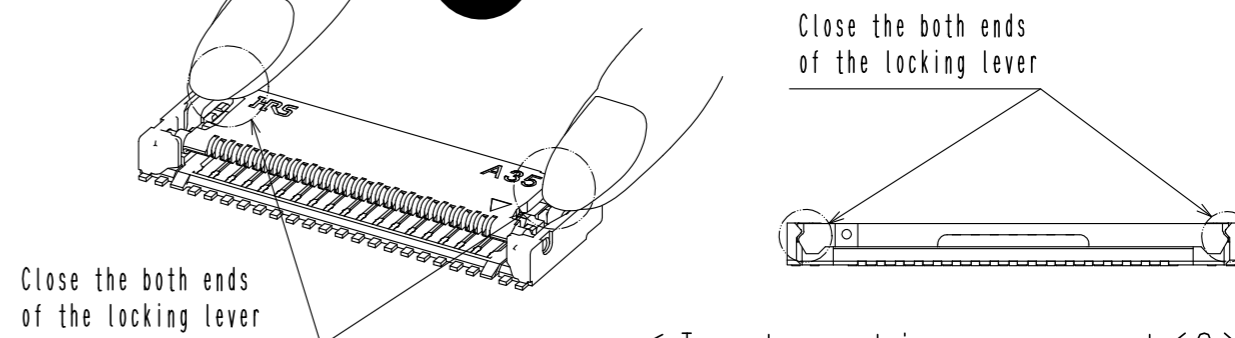

<Instruction manual(3)>

HRS

DRAWING NO.	EDC-368163-10-01
PART NO.	FH62-**S-0.25SHW<10>
CODE NO.	CL580

4/7/9

Jun.1.2024 Copyright 2024 HIROSE ELECTRIC CO., LTD. All Rights Reserved.
In case of consideration for using Automotive equipment / device which demand high reliability, kindly contact our sales window correspondents.

[Precautions for component layout]

Depending on a FPC rounding, a load is applied to the connector, and a contact failure may occur. To prevent a failure, take the following notes into a consideration during mechanism design.

[Caution]

- When fixing FPC after FPC cabling, avoid pulling FPC, and route the wire FPC with slack. In this regard, the stiffener is parallel to the PCB (Example23).
- Avoid applying forces to FPC in vertical or horizontal directions. Do not bend the FPC excessively near the connector during use, or it may cause contact failure or FPC breakage. Stabilizing the FPC is recommended (Example 24, 25).
- Do not mount other components touching to the FPC underneath the FPC stiffener (Example26).
- Make adjustments with the FPC manufacturer for FPC bending performance and wire breakage.
- Keep a sufficient FPC insertion space in the stage of the layout in order to avoid incorrect FPC insertion. Appropriate FPC length and component layout are recommended for assembly ease. Too short FPC length makes assembly difficult.
- Keep spaces for the locking lever movement and its operation for PCB design and component layout.
- ⚠ Please consult with our sales representative if you are using FPC with different configuration from our recommendation.

[Instructions for mounting on the PCB]

Follow the instructions shown below when mounting on the PCB.

[Caution]

- Refer to recommended layouts on the page 1 for PCB and stencil pattern.
- Shorter pattern width than the recommended PCB dimension, could cause solder wicking and/or flux penetration.
- Larger pattern than the recommended stencil dimension, could cause solder wicking and/or flux penetration.
- Clearance underneath the contact lead and the housing is very small. In case solder resist and/or silk screening are applied on PCB underneath the connector, verify the thickness, or it could push up the connector bottom and may cause soldering defect and/or insufficient fillet formation.
- Prevent warpage of PCB, where possible, since it can cause soldering failure :even with 0.1 mm max coplanarity.
- When mounting on the flexible board, please make sure to put a stiffener on the backside of the flexible board. We recommend a glass epoxy material with the thickness of 0.3 mm min.
- Do not add 1.0 N or greater external force when unreel or pick and place the connector etc. or it may get broken.
- ⚠ Apply reflow temperature profile within the specified conditions. For specific applications, the recommended temperature may vary depending on type/ volume/thickness of solder paste and size/thickness of PCB. Please consult with your solder paste and equipment manufacturer for specific recommendations. The temperatures mentioned below refer to the PCB surface temperature near the connector contact leads.
 - Reflow method: IR reflow
 - Number of reflow cycles: 2 cycles MAX.

Example 23)

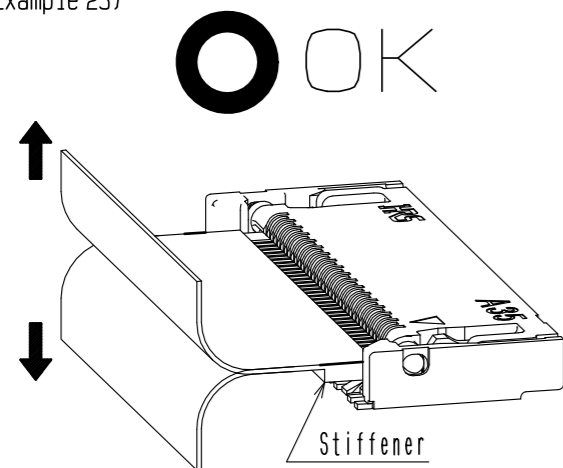

Example 24)

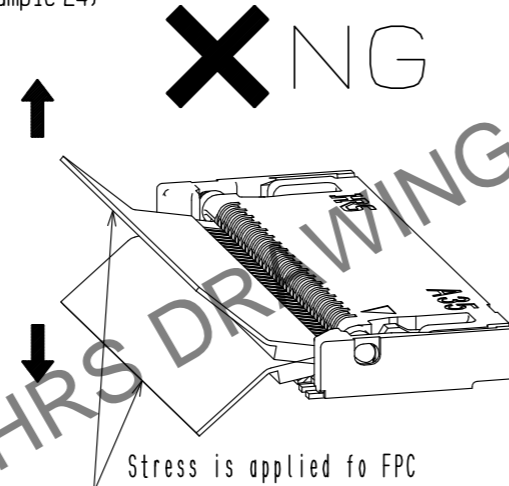

Example 25)

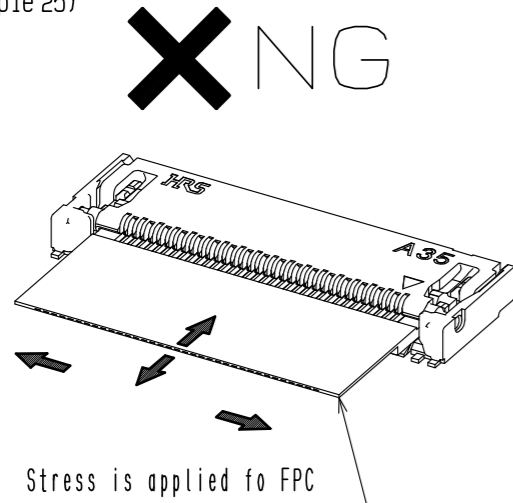

Example 26)

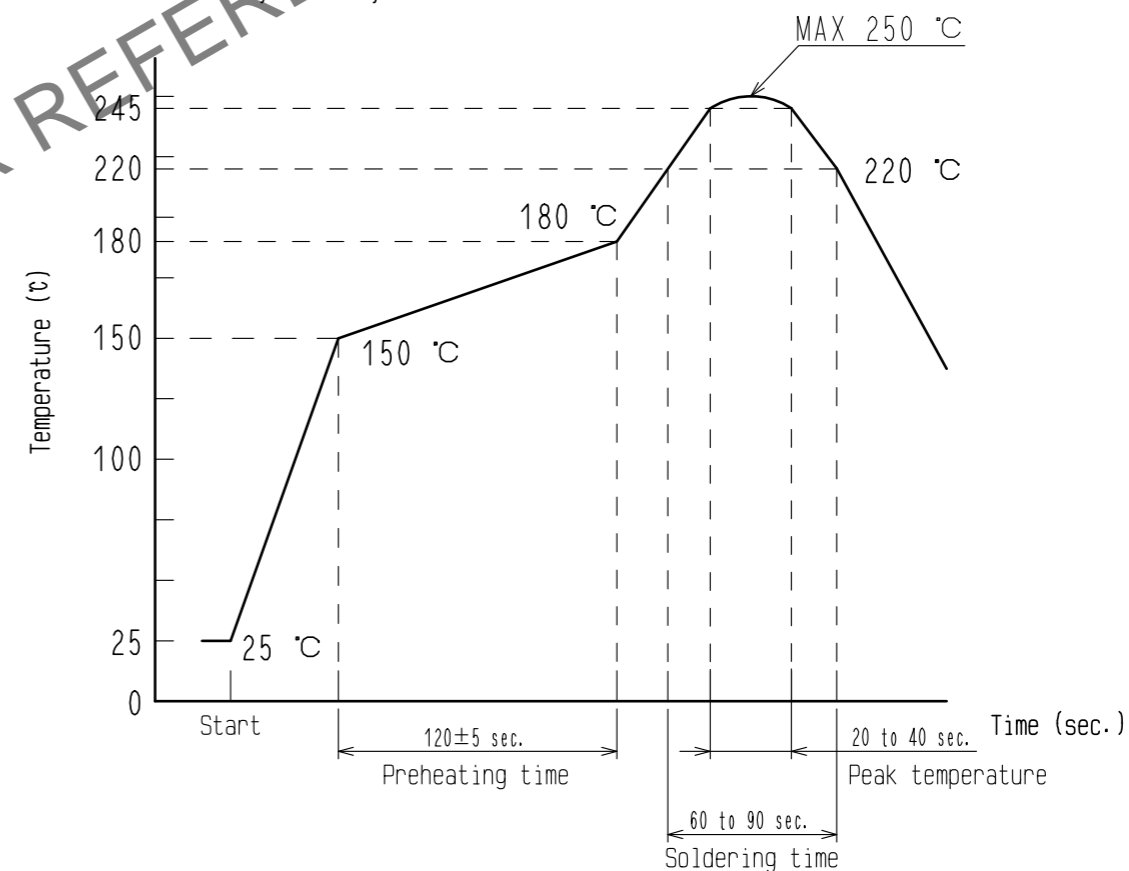
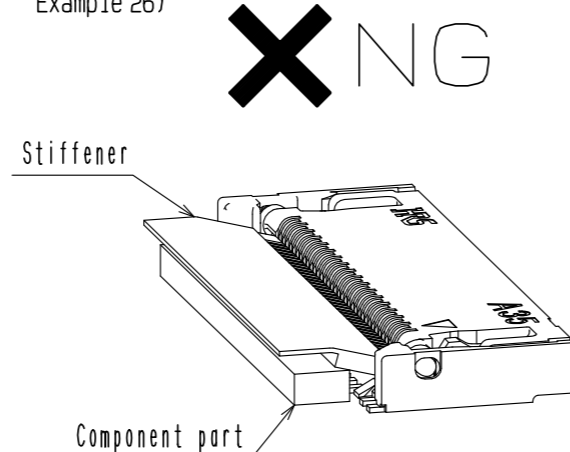

<Instruction manual(4)>

HRS	DRAWING NO.	EDC-368163-10-01
	PART NO.	FH62-**S-0.25SHW(10)
	CODE NO.	CL580
		⚠ 8/9

Jun.1.2024 Copyright 2024 HIROSE ELECTRIC CO., LTD. All Rights Reserved.
In case of consideration for using Automotive equipment / device which demand high reliability, kindly contact our sales window correspondents.

[Instructions for PCB handling after mounting the connector]
Follow the instructions shown below when mounting on the PCB.

[Caution]

- Splitting a large PCB into several pieces
- Screwing the PCB

During the handling described above, do not exert an excessive force on the PCB.
Otherwise, the connector may become defective.

- The warp of a 100 mm wide PCB should be 1.0 mm or less.
The warp of PCB suffers stress on connector and the connector may become defective (Example 27).

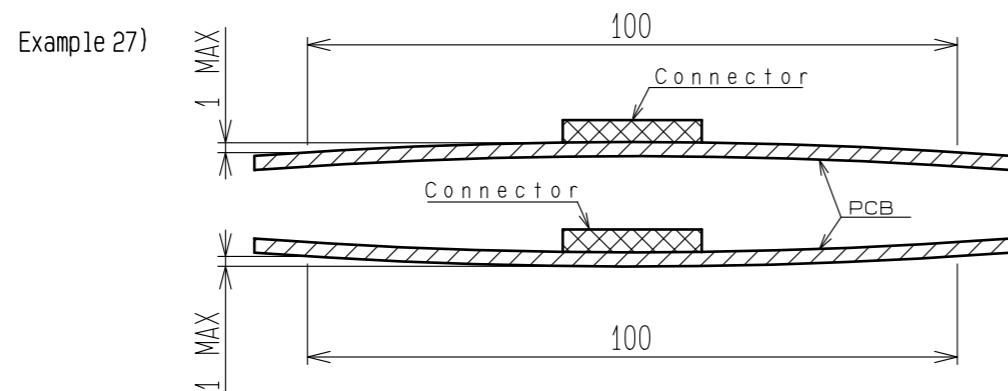

[Instructions on manual soldering]

Follow the instructions shown below when soldering the connector manually during repair work, etc.

[Caution]

- Do not perform manual soldering with the FPC inserted into the connector.
- Do not heat the connector excessively. Be very careful not to let the soldering iron contact any parts other than connector leads. Otherwise, the connector may be deformed or melt.
- Do not supply excessive solder (or flux).
If excessive solder (or flux) is supplied on the terminals, solder or flux may adhere to the contacts, resulting in poor contact.

HRS DRAWING FOR REFERENCE

<Instruction manual(5)>

HRS	DRAWING NO.	EDC-368163-10-01
	PART NO.	FH62-**-S-0.25SHW<10>
	CODE NO.	CL580

4/9

Looking for pricing, stock, or lifecycle information?

Click below to explore more details on WIN SOURCE:

- ⊖ [View FH62-35S-0.25SHW\(10\) on WIN SOURCE](#)
- ⊖ [Hirose Electric Co Ltd Information](#)

Optimize Your Supply Chain with WIN SOURCE Solutions

- ✓ Global Sourcing Solution
- ✓ Obsolete Management
- ✓ Cost Control Management
- ✓ Shortage Management
- ✓ Alternative Solution
- ✓ Excess Inventory Management