



**THE DATASHEET OF
831752AGILFT**



General Description

The 831752 is a high-performance, differential HCSL clock switch. The device is designed for the routing of PCIe clock signals in ATCA/AMC system and is optimized for PCIe Gen 1, Gen 2 and Gen 3. The device has one differential, bi-directional I/O (FCLK) for connection to ATCA clock sources and to clock receivers through a connector. The differential clock input CLK is the local clock input and the HCSL output Q is the local clock output. In the common clock mode, FCLK serves as an input and is routed to the differential HCSL output Q. There are two local clock modes. In the local clock mode 0, CLK is the input, Q is the clock output and FCLK is in high-impedance state. In the local clock mode 1, CLK is the input and both Q and FCLK are the outputs of the locally generated PCIe clock signal. The 831752 is characterized to operate from a 3.3V power or 2.5V power supply. The 831752 supports the switching of PCI Express (2.5 Gb/s), Gen 2 (5 Gb/s) and Gen 3 (8 Gb/s) clock signals.

Features

- Clock switch for PCIe and ATCA/AMC applications
- Supports local and common ATCA/AMC clock modes
- Bi-directional clock I/O FCLK:
 - When operating as an output, FCLK is a source-terminated HCSL signal.
 - When operating as an input, FCLK accepts HCSL, LVDS and LVPECL levels.
- Local clock input (CLK) accepts HCSL, LVDS and LVPECL differential signals
- Local HCSL clock output (Q)
- Maximum input/output clock frequency: 500MHz
- Maximum input/output data rate: 1000Mb/s (NRZ)
- LVCMOS interface levels for the control inputs
- PCI Express (2.5 Gb/s), Gen 2 (5 Gb/s) and Gen 3 (8 Gb/s) jitter compliant
- Full 3.3V or 2.5V supply voltage
- Lead-free (RoHS 6) 16-lead TSSOP package
- -40°C to 85°C ambient operating temperature

Pin Assignment

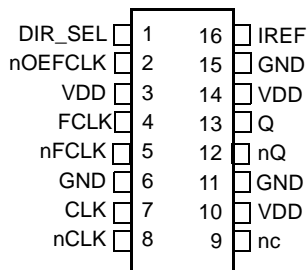

831752

16-lead TSSOP

4.4mm x 5.0mm x 0.925mm package body
G Package, Top View

Block Diagram

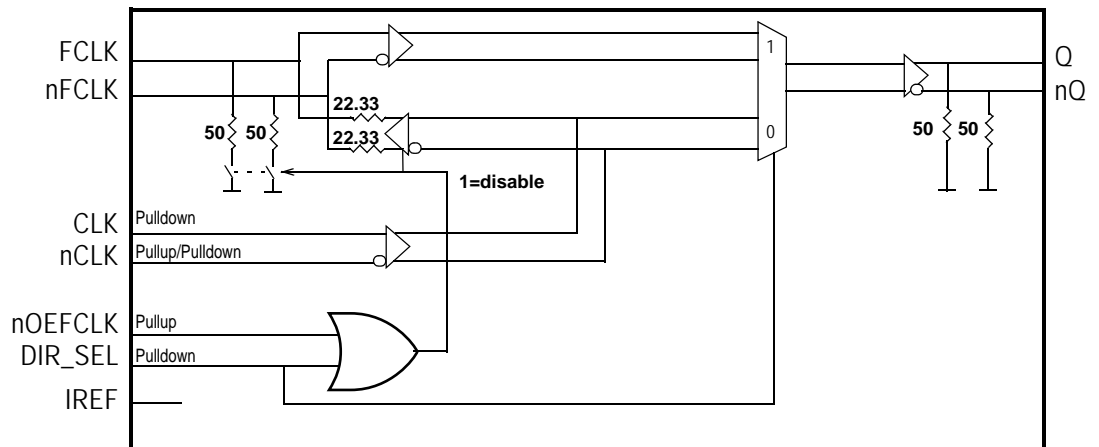

Table 1. Pin Descriptions

Number	Name	Type		Description
1	DIR_SEL	Input	Pulldown	Direction control for the FCLK I/O. Works in conjunction with nOEFCLK. See Table 3 for function. LVCMOS/LVTTL interface levels.
2	nOEFCLK	Input	Pullup	Output enable for the FCLK I/O output. Works in conjunction with DIR_SEL. See Table 3 for function. LVCMOS/LVTTL interface levels.
3, 10, 14	V _{DD}	Power		Core and output power supply pin.
4, 5	FCLK, nFCLK	I/O		Differential I/O. Signal direction is controlled by DIR_SEL. Accepts differential signals when operating as an input. Differential HCSL signals when operating as an output. Internal source termination can be disabled. See Table 3 for function.
6, 11, 15	GND	Power		Power supply ground.
7	CLK	Input	Pulldown	Non-inverting input.
8	nCLK	Input	Pulldown/Pullup	Inverting differential clock input.
9	nc	Unused		No connect.
12, 13	nQ, Q	Output		Differential output pair. HCSL interface levels.
16	IREF	Input		An external fixed precision resistor (475Ω) from this pin to ground provides a reference current used for the differential current-mode Q and FCLK outputs.

NOTE: Pullup and pulldown refer to internal input resistors. See Table 2, *Pin Characteristics*, for typical values.

Table 2. Pin Characteristics

Symbol	Parameter	Test Conditions	Minimum	Typical	Maximum	Units
C _{IN}	Input Capacitance			4		pF
R _{PULLDOWN}	Input Pulldown Resistor			51		kΩ
R _{PULLUP}	Input Pullup Resistor			51		kΩ

Function Table

Table 3. Direction Control Function Table

Input	Input	Operation	FCLK Function
DIR_SEL	nOEFCLK		
0	0	Local clock mode 0. The input signal at CLK is routed to both outputs Q and FCLK.	Differential HCSL output with internal 50Ω source termination
0 (default)	1 (default)	Local clock mode 1. The input signal at CLK is routed to the output Q.	Output is disabled (high impedance). Internal 50Ω termination is disabled.
1	X	Common reference clock mode. FCLK is the clock input. Q is the clock output.	Differential clock input. Internal 50Ω source termination is disabled as well as output driver and 22.33Ω resistors.

NOTE: X = 0 or 1

Absolute Maximum Ratings

NOTE: Stresses beyond those listed under *Absolute Maximum Ratings* may cause permanent damage to the device. These ratings are stress specifications only. Functional operation of product at these conditions or any conditions beyond those listed in the *DC Characteristics* or *AC Characteristics* is not implied. Exposure to absolute maximum rating conditions for extended periods may affect product reliability.

Item	Rating
Supply Voltage, V_{DD}	4.6V
Inputs, V_I	-0.5V to $V_{DD} + 0.5V$
Outputs, V_O	-0.5V to $V_{DD} + 0.5V$
Package Thermal Impedance, θ_{JA}	81.2°C/W (0 mps)
Storage Temperature, T_{STG}	-65°C to 150°C

DC Electrical Characteristics

Table 4A. Power Supply DC Characteristics, $V_{DD} = 3.3V \pm 5\%$ or $2.5V \pm 5\%$, $T_A = -40^\circ\text{C}$ to 85°C

Symbol	Parameter	Test Conditions	Minimum	Typical	Maximum	Units
V_{DD}	Core Supply Voltage		3.135	3.3	3.465	V
			2.375	2.5	2.625	V
I_{DD}	Power Supply Current				64	mA

Table 4B. LVCMOS/LVTTL DC Characteristics, $V_{DD} = 3.3V \pm 5\%$ or $2.5V \pm 5\%$, $T_A = -40^\circ\text{C}$ to 85°C

Symbol	Parameter	Test Conditions	Minimum	Typical	Maximum	Units
V_{IH}	Input High Voltage	$V_{DD} = 3.3V$	2		$V_{DD} + 0.3$	V
		$V_{DD} = 2.5V$	1.7		$V_{DD} + 0.3$	V
V_{IL}	Input Low Voltage	$V_{DD} = 3.3V$	-0.3		0.8	V
		$V_{DD} = 2.5V$	-0.3		0.7	V
I_{IH}	Input High Current	$V_{DD} = V_{IN} = 2.625V$ or $3.465V$			150	μA
					5	μA
I_{IL}	Input Low Current	$V_{DD} = 2.625V$ or $3.465V$, $V_{IN} = 0V$		-5		μA
				-150		μA

Table 4C. Differential DC Characteristics, $V_{DD} = 3.3V \pm 5\%$ or $2.5V \pm 5\%$, $T_A = -40^\circ\text{C}$ to 85°C

Symbol	Parameter	Test Conditions	Minimum	Typical	Maximum	Units
I_{IH}	Input High Current	CLK, nCLK $V_{DD} = V_{IN} = 3.3V$			150	μA
I_{IL}	Input Low Current	CLK $V_{DD} = 3.3V$, $V_{IN} = 0V$	-5			μA
		nCLK $V_{DD} = 3.3V$, $V_{IN} = 0V$	-150			μA
V_{PP}	Peak-to-Peak Voltage; NOTE 1		0.15		1.3	V
V_{CMR}	Common Mode Input Voltage; NOTE 1, 2		0.5		$V_{DD} - 0.85$	V

NOTE 1: V_{IL} should not be less than -0.3V.

NOTE 2: Common mode input voltage is defined as V_{IH} .

AC Electrical Characteristics

Table 5A. PCI Express Jitter Specifications, $V_{DD} = 3.3V \pm 5\%$ or $2.5V \pm 5\%$, $T_A = -40^\circ C$ to $85^\circ C$

Symbol	Parameter	Test Conditions	Minimum	Typical	Maximum	PCIe Industry Specification	Units
t_j (PCIe Gen 1)	Phase Jitter Peak-to-Peak; NOTE 1, 4	$f = 100MHz$ Evaluation Band: 0Hz - Nyquist (clock frequency/2)		9.95	15.5	86	ps
$t_{REFCLK_HF_RMS}$ (PCIe Gen 2)	Phase Jitter RMS; NOTE 2, 4	$f = 100MHz$ High Band: 1.5MHz - Nyquist (clock frequency/2)		0.82	1.12	3.1	ps
$t_{REFCLK_LF_RMS}$ (PCIe Gen 2)	Phase Jitter RMS; NOTE 2, 4	$f = 100MHz$ Low Band: 10kHz - 1.5MHz		0.04	0.08	3.0	ps
t_{REFCLK_RMS} (PCIe Gen 3)	Phase Jitter RMS; NOTE 3, 4	$f = 100MHz$ Evaluation Band: 0Hz - Nyquist (clock frequency/2)		0.153	0.203	0.8	ps

NOTE: Electrical parameters are guaranteed over the specified ambient operating temperature range, which is established when the device is mounted in a test socket with maintained transverse airflow greater than 500 lfm. The device will meet specifications after thermal equilibrium has been reached under these conditions. For additional information, refer to the *PCI Express Application Note section* in the datasheet.

NOTE: PCI Express Jitter Specifications apply to FCLK and nFCLK and Q, nQ operating as outputs. The source generator used in the PCI Express Jitter measurements is the Stanford Research Systems CG635 2.0GHz Synthesized Clock Generator.

NOTE 1: Peak-to-Peak jitter after applying system transfer function for the Common Clock Architecture. Maximum limit for PCI Express Gen 1 is 86ps peak-to-peak for a sample size of 10^6 clock periods.

NOTE 2: RMS jitter after applying the two evaluation bands to the two transfer functions defined in the Common Clock Architecture and reporting the worst case results for each evaluation band. Maximum limit for PCI Express Gen 2 is 3.1ps RMS for $t_{REFCLK_HF_RMS}$ (High Band) and 3.0ps RMS for $t_{REFCLK_LF_RMS}$ (Low Band).

NOTE 3: RMS jitter after applying system transfer function for the common clock architecture. This specification is based on the *PCI Express Base Specification Revision 0.7, October 2009* and is subject to change pending the final release version of the specification.

NOTE 4: This parameter is guaranteed by characterization. Not tested in production.

Table 5B. HCSL AC Characteristics, $V_{DD} = 3.3V \pm 5\%$ or $2.5V \pm 5\%$, $T_A = -40^\circ C$ to $85^\circ C$

Symbol	Parameter	Test Conditions	Minimum	Typical	Maximum	Units
f_{OUT}	Output Frequency			100	500	MHz
f_{jit}	Buffer Additive Phase Jitter, RMS; refer to Additive Phase Jitter Plot	100MHz, Integration Range: 12kHz – 20MHz		0.3	0.505	ps
t_{PD}	Propagation Delay, NOTE 1	FCLK to Q	1.75		3.65	ns
		CLK to Q	1.95		3.90	ns
		CLK to FCLK	1.50		3.70	ns
MUX_{ISOL}	Mux Isolation	$f = 100MHz$		-70		dB
Edge Rate	Rise/Fall Edge Rate; NOTE 2, 3		0.6		4	V/ns
V_{RB}	Ringback Voltage; NOTE 2, 4		-100		100	mV
t_{STABLE}	Time before V_{RB} is allowed; NOTE 2, 4		500			ps
V_{MAX}	Absolute Max Output Voltage; NOTE 5, 6			800	1350	mV
V_{MIN}	Absolute Min Output Voltage; NOTE 5, 7		-300	-35		mV
V_{CROSS}	Absolute Crossing Voltage; NOTE 5, 8, 9		250	385	650	mV
ΔV_{CROSS}	Total Variation of V_{CROSS} over all edges; NOTE 5, 8, 10			40	140	mV
odc	Output Duty Cycle; NOTE 11	$f \leq 312.5MHz$	44	50	56	%
		$f > 312.5MHz$	40	50	60	

NOTE: Measurements taken with Q output and FCLK output.

NOTE: Electrical parameters are guaranteed over the specified ambient operating temperature range, which is established when the device is mounted in a test socket with maintained transverse airflow greater than 500 lpm. The device will meet specifications after thermal equilibrium has been reached under these conditions.

NOTE: All measurements were taken with FCLK, nFCLK and Q, nQ operating as outputs unless otherwise noted.

NOTE 1: Measured from the differential input cross point to the differential output crossing point.

NOTE 2: Measurement taken from differential waveform.

NOTE 3: Measurement from -150mV to +150mV on the differential waveform (derived from Q minus nQ). The signal must be monotonic through the measurement region for rise and fall time. The 300mV measurement window is centered on the differential zero crossing.

NOTE 4: T_{STABLE} is the time the differential clock must maintain a minimum $\pm 150mV$ differential voltage after rising/falling edges before it is allowed to drop back into the $V_{RB} \pm 100$ differential range. See Parameter Measurement Information Section.

NOTE 5: Measurement taken from single-ended waveform.

NOTE 6: Defined as the maximum instantaneous voltage including overshoot. See Parameter Measurement Information Section.

NOTE 7: Defined as the minimum instantaneous voltage including undershoot. See Parameter Measurement Information Section.

NOTE 8: Measured at crossing point where the instantaneous voltage value of the rising edge of Q equals the falling edge of nQ.

See Parameter Measurement Information Section.

NOTE 9: Refers to the total variation from the lowest crossing point to the highest, regardless of which edge is crossing. Refers to all crossing points for this measurement. See Parameter Measurement Information Section.

NOTE 10: Defined as the total variation of all crossing voltage of rising Q and falling nQ. This is the maximum allowed variance in the V_{CROSS} for any particular system. See Parameter Measurement Information Section.

NOTE 11: Input duty cycle must be 50%.

NOTE 12: Matching applies to rising edge rate for Q and falling edge rate for nQ. It is measured using a $\pm 75mV$ window centered on the median crosspoint where Q meets nQ falling. The median crosspoint is used to calculate the voltage thresholds the oscilloscope is to use for the edge rate calculations. The rise edge rate of Q should be compared to the fall edge rate of nQ, the maximum allowed difference should not exceed 20% of the slowest edge rate.

Parameter Measurement Information

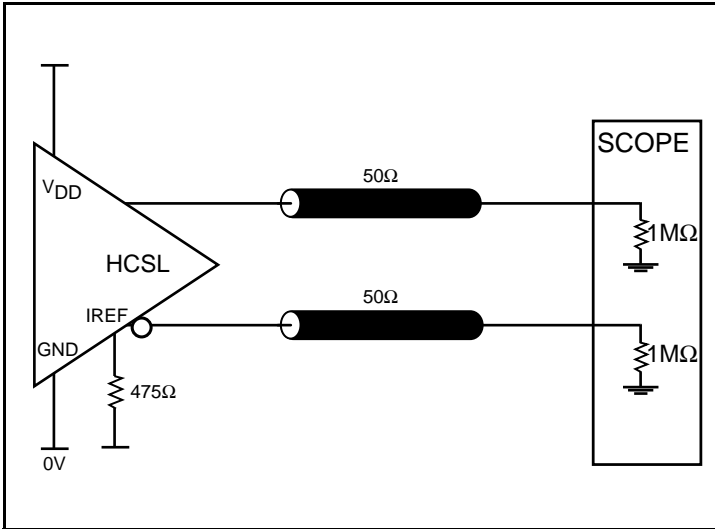

HCSL Output Load AC Test Circuit

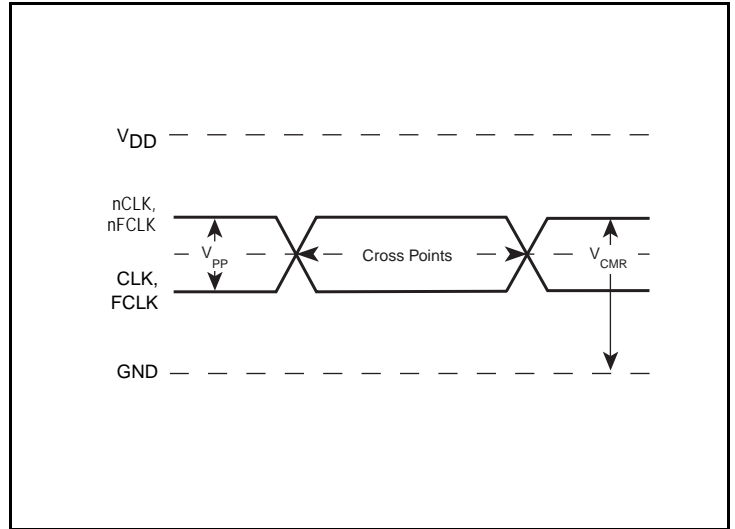

Differential Input Levels

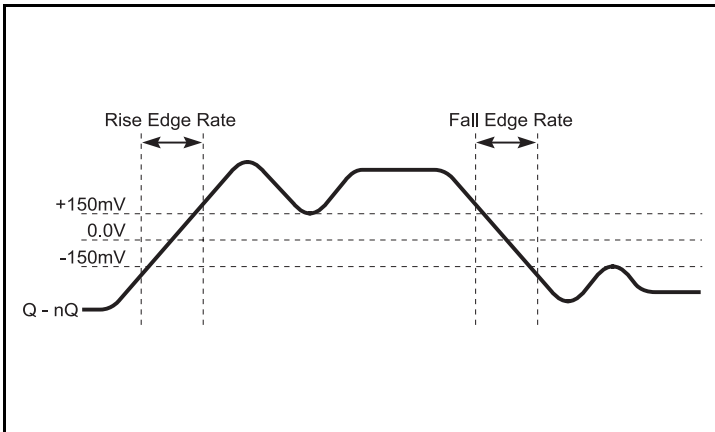

Differential Measurement Points for Rise/Fall Edge Rate

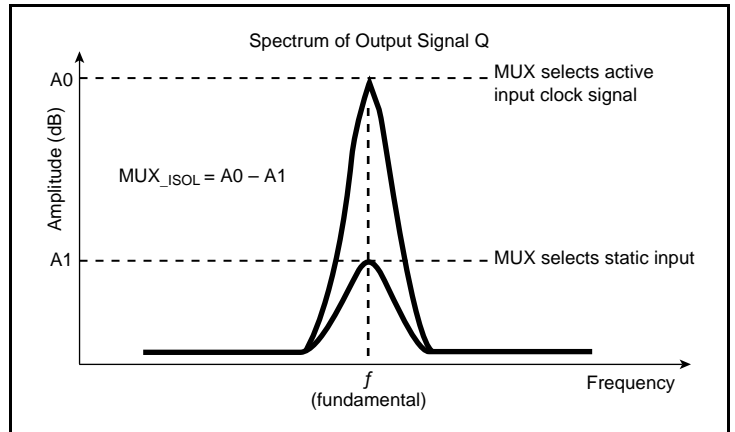

MUX_ISOLATION

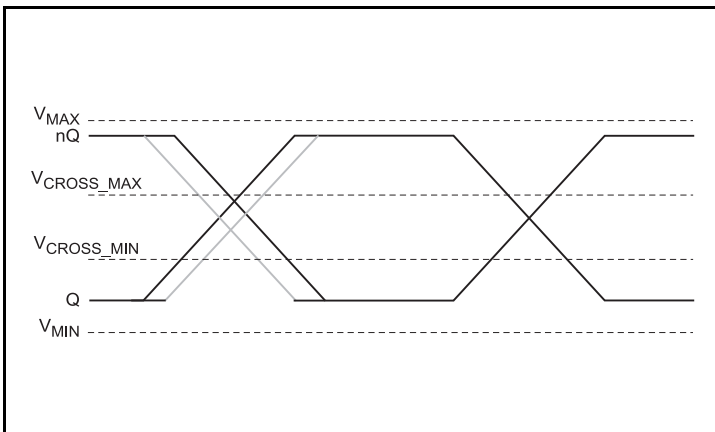

Single-ended Measurement Points for Absolute Cross Point/Swing

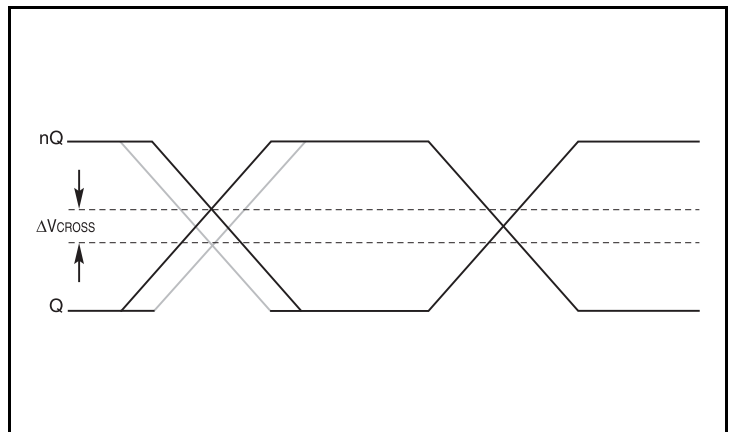

Single-ended Measurement Points for Delta Cross Point

Parameter Measurement Information, continued

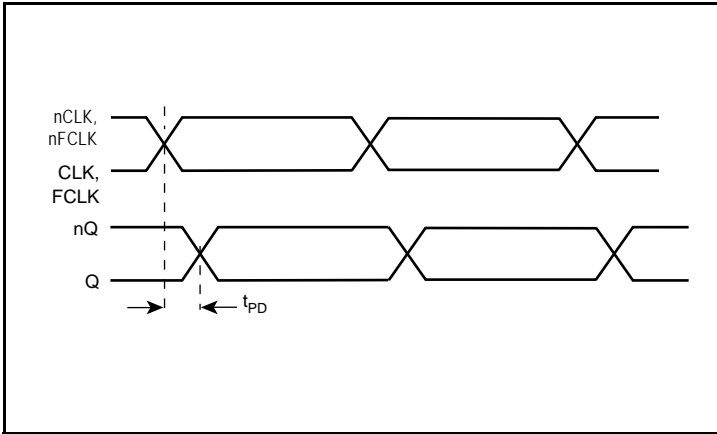

Propagation Delay

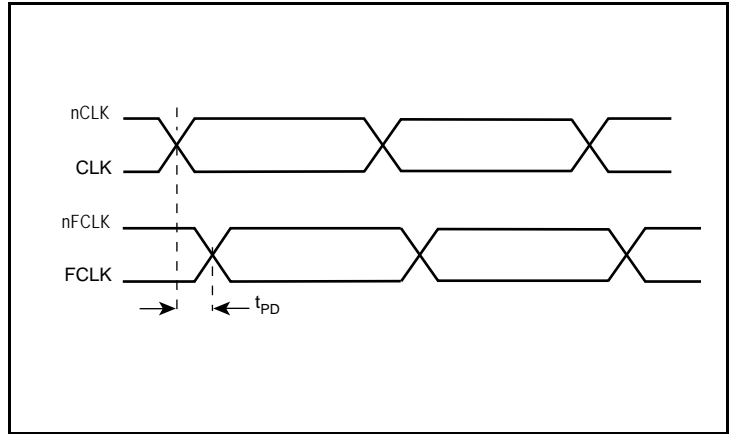

Propagation Delay

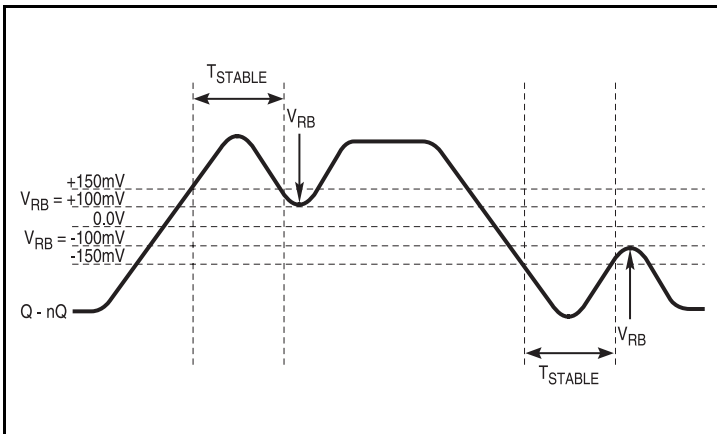

Differential Measurement Points for Ringback

Applications Information

Recommended Termination

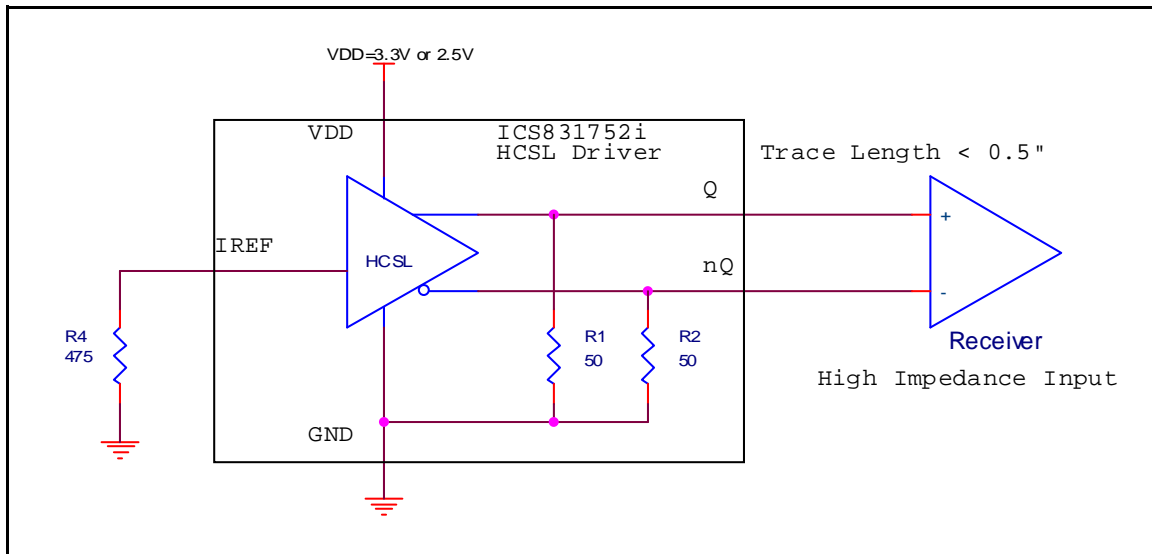

Figure 1. Interface for 831752I HCSL driver with built-in 50 ohm Termination to Receiver with High Input Impedance

Recommendations for Unused Input Pins

Inputs:

LVC MOS Control Pins

All control pins have internal pullups or pulldowns; additional resistance is not required but can be added for additional protection. A 1kΩ resistor can be used.

CLK/nCLK Inputs

For applications not requiring the use of the differential input, both CLK and nCLK can be left floating. Though not required, but for additional protection, a 1kΩ resistor can be tied from CLK to ground.

FCLK/nFCLK Pins

In case FCLK/nFCLK are unused, one of the following two configurations can be used: either FCLK/nFCLK are configured as an output (DIR_SEL = 1) and left floating, or FCLK/nFCLK are configured as an input (DIR_SEL = 0). In this case 1kΩ pulldown is required on FCLK and 1kΩ Pullup is required on nFCLK.

Wiring the Differential Input to Accept Single-Ended Levels

Figure 2 shows how a differential input can be wired to accept single ended levels. The reference voltage $V_1 = V_{DD}/2$ is generated by the bias resistors R1 and R2. The bypass capacitor (C1) is used to help filter noise on the DC bias. This bias circuit should be located as close to the input pin as possible. The ratio of R1 and R2 might need to be adjusted to position the V_1 in the center of the input voltage swing. For example, if the input clock swing is 2.5V and $V_{DD} = 3.3V$, R1 and R2 value should be adjusted to set V_1 at 1.25V. The values below are for when both the single ended swing and V_{DD} are at the same voltage. This configuration requires that the sum of the output impedance of the driver (R_o) and the series resistance (R_s) equals the transmission line impedance. In addition, matched termination at the input will attenuate the signal in half. This can be done in one of two ways. First, R3 and R4 in parallel should equal the transmission

line impedance. For most 50Ω applications, R3 and R4 can be 100Ω. The values of the resistors can be increased to reduce the loading for slower and weaker LVC MOS driver. When using single-ended signaling, the noise rejection benefits of differential signaling are reduced. Even though the differential input can handle full rail LVC MOS signaling, it is recommended that the amplitude be reduced. The datasheet specifies a lower differential amplitude, however this only applies to differential signals. For single-ended applications, the swing can be larger, however V_{IL} cannot be less than -0.3V and V_{IH} cannot be more than $V_{DD} + 0.3V$. Though some of the recommended components might not be used, the pads should be placed in the layout. They can be utilized for debugging purposes. The datasheet specifications are characterized and guaranteed by using a differential signal.

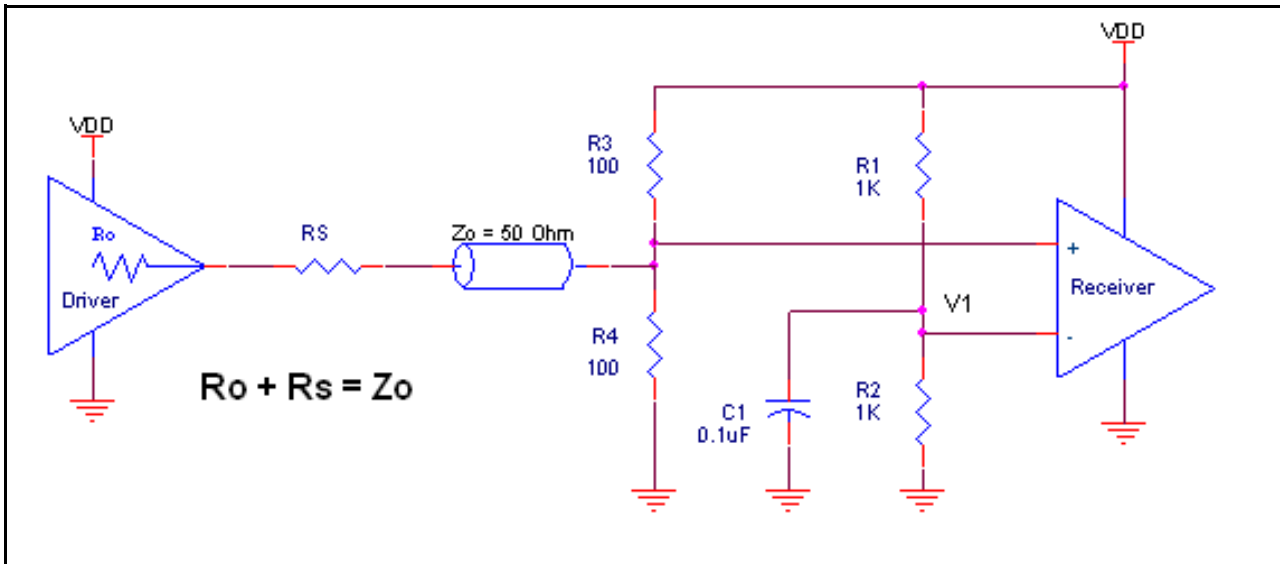

Figure 2. Recommended Schematic for Wiring a Differential Input to Accept Single-ended Levels

3.3V Differential Clock Input Interface

The CLK/nCLK accepts HCSL, LVDS and LVPECL and other differential signals. Both differential signals must meet the V_{PP} and V_{CMR} input requirements. Figures 2A to 2E show interface examples for the CLK/nCLK input driven by the most common driver types. The input interfaces suggested here are examples only. If the driver is

from another vendor, use their termination recommendation. Please consult with the vendor of the driver component to confirm the driver termination requirements. The figures below also apply to FCLK/nFCLK operating as an input.

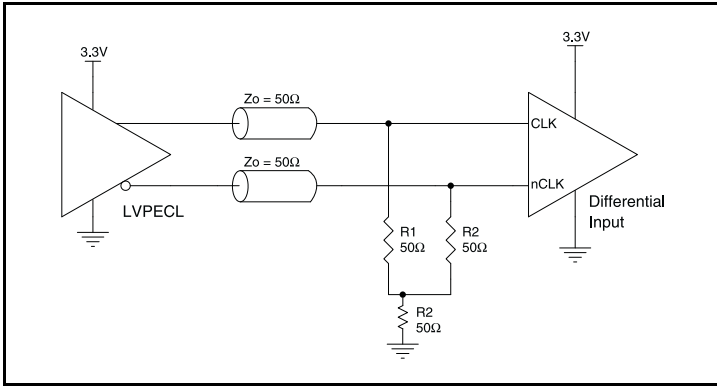

Figure 3A. CLK/nCLK Input Driven by a 3.3V LVPECL Driver

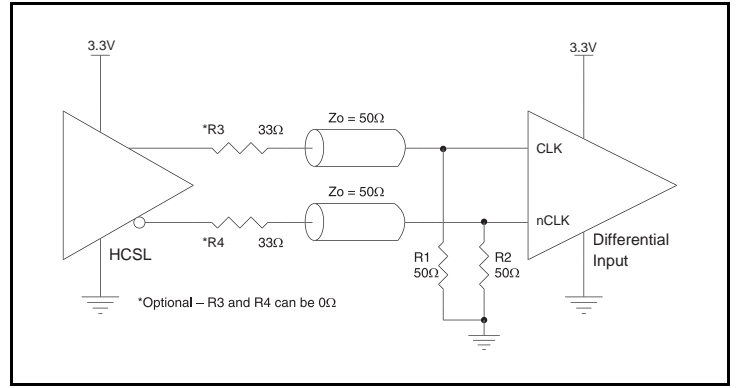

Figure 3B. CLK/nCLK Input Driven by a 3.3V HCSL Driver

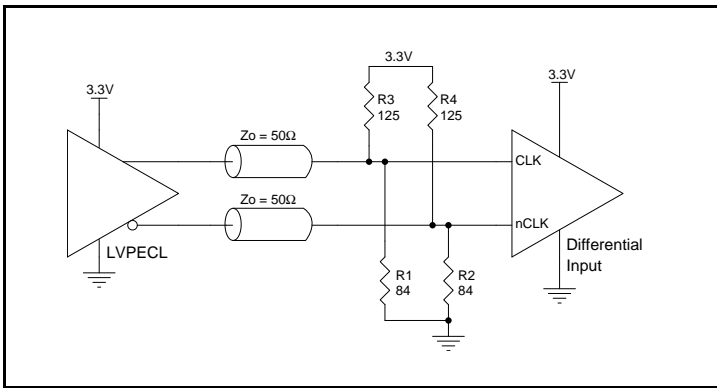

Figure 3C. CLK/nCLK Input Driven by a 3.3V LVPECL Driver

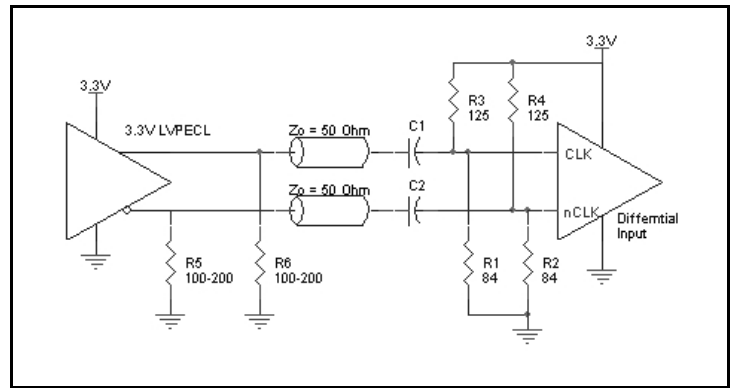

Figure 3D. CLK/nCLK Input Driven by a 3.3V LVPECL Driver with AC Couple

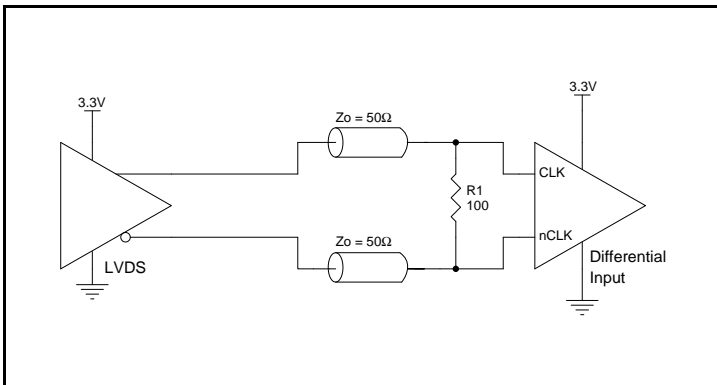

Figure 3E. CLK/nCLK Input Driven by a 3.3V LVDS Driver

2.5V Differential Clock Input Interface

The CLK/nCLK accepts HCSSL, LVDS and LVPECL and other differential signals. Both differential signals must meet the V_{PP} and V_{CMR} input requirements. *Figures 4A to 4 E* show interface examples for the CLK/nCLK input driven by the most common driver types. The input interfaces suggested here are examples only. If the driver is

from another vendor, use their termination recommendation. Please consult with the vendor of the driver component to confirm the driver termination requirements. The figures below also apply to FCLK/nFCLK operating as an input.

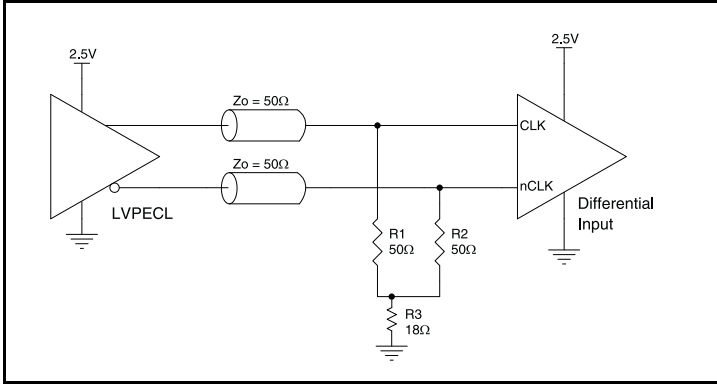

Figure 4A. CLK/nCLK Input Driven by a 2.5V LVPECL Driver

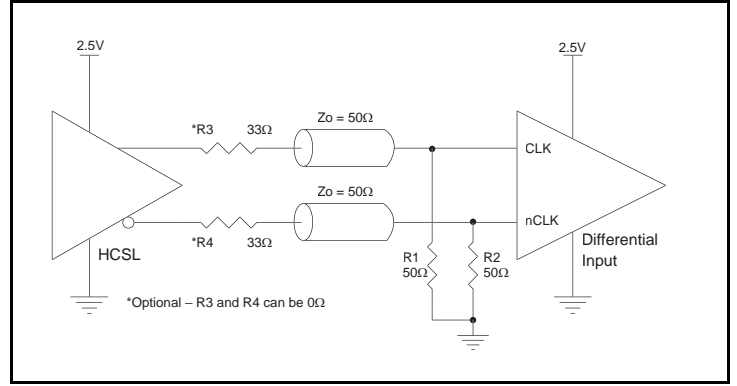

Figure 4B. CLK/nCLK Input Driven by a 2.5V HCSSL Driver

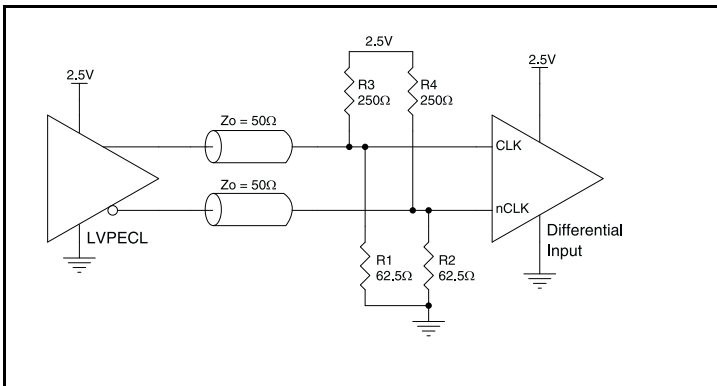

Figure 4C. CLK/nCLK Input Driven by a 2.5V LVPECL Driver

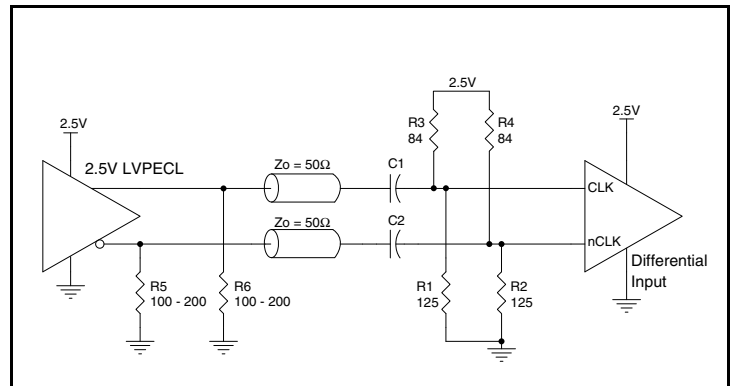

Figure 4D. CLK/nCLK Input Driven by a 2.5V LVPECL Driver with AC Couple

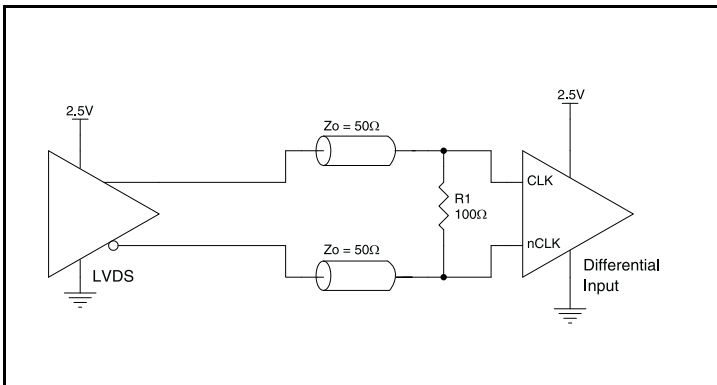

Figure 4E. CLK/nCLK Input Driven by a 2.5V LVDS Driver

PCI Express Application Note

PCI Express jitter analysis methodology models the system response to reference clock jitter. The block diagram below shows the most frequently used *Common Clock Architecture* in which a copy of the reference clock is provided to both ends of the PCI Express Link.

In the jitter analysis, the transmit (Tx) and receive (Rx) serdes PLLs are modeled as well as the phase interpolator in the receiver. These transfer functions are called H1, H2, and H3 respectively. The overall system transfer function at the receiver is:

$$Ht(s) = H3(s) \times [H1(s) - H2(s)]$$

The jitter spectrum seen by the receiver is the result of applying this system transfer function to the clock spectrum X(s) and is:

$$Y(s) = X(s) \times H3(s) \times [H1(s) - H2(s)]$$

In order to generate time domain jitter numbers, an inverse Fourier Transform is performed on $X(s) \times H3(s) \times [H1(s) - H2(s)]$.

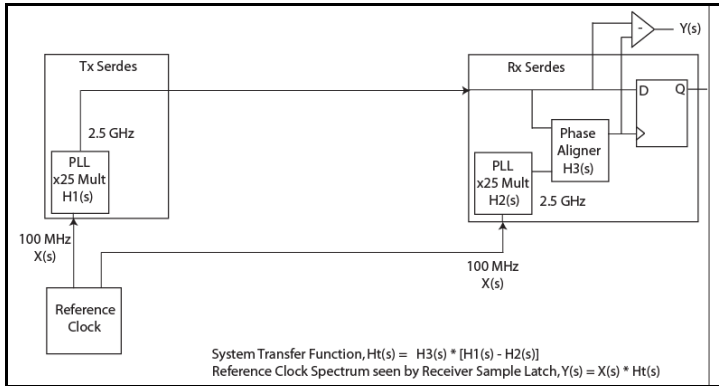

PCI Express Common Clock Architecture

For PCI Express Gen 1, one transfer function is defined and the evaluation is performed over the entire spectrum: DC to Nyquist (e.g for a 100MHz reference clock: 0Hz – 50MHz) and the jitter result is reported in peak-peak.

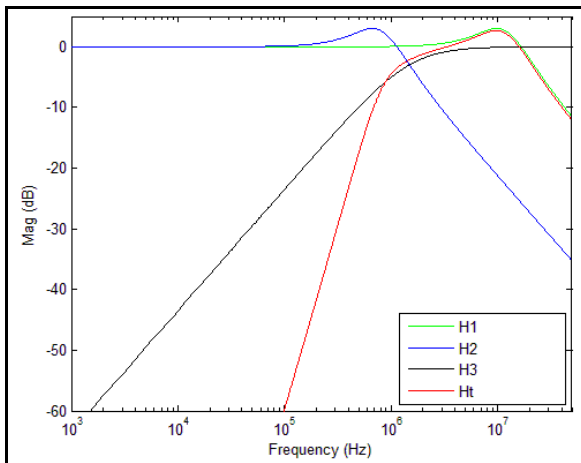

PCI Express Gen 1 Magnitude of Transfer Function

For PCI Express Gen 2, two transfer functions are defined with 2 evaluation ranges and the final jitter number is reported in rms. The two evaluation ranges for PCI Express Gen 2 are 10kHz – 1.5MHz (Low Band) and 1.5MHz – Nyquist (High Band). The plots show the individual transfer functions as well as the overall transfer function Ht.

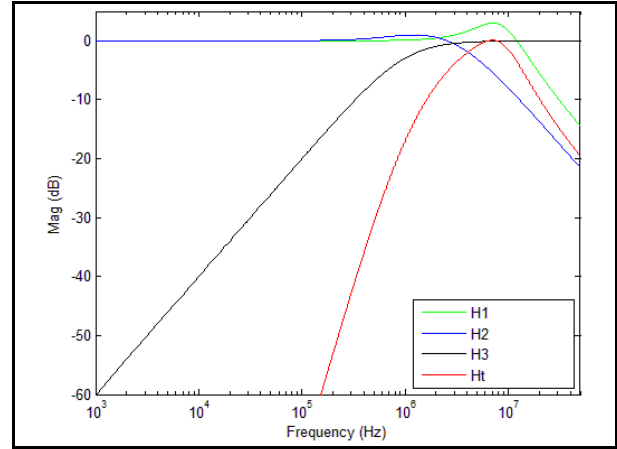

PCI Express Gen 2A Magnitude of Transfer Function

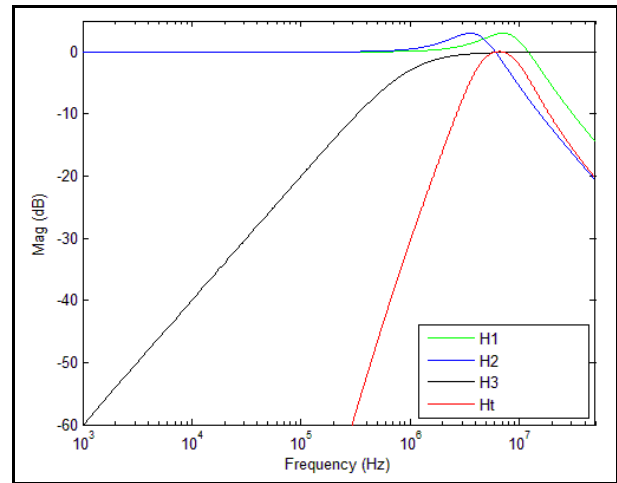

PCI Express Gen 2B Magnitude of Transfer Function

PCI Express Application Note.

For PCI Express Gen 3, one transfer function is defined and the evaluation is performed over the entire spectrum. The transfer function parameters are different from Gen 1 and the jitter result is reported in RMS.

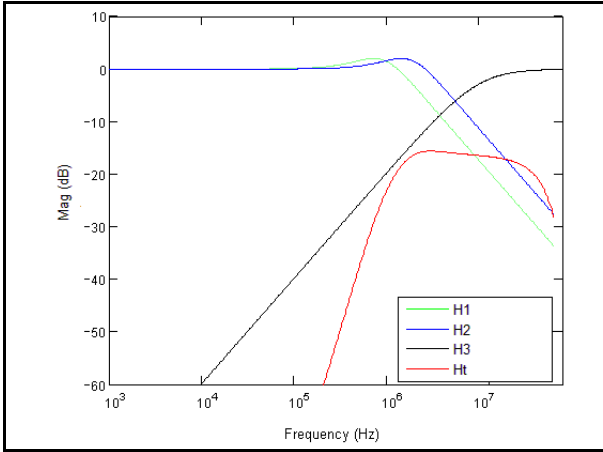

PCIe Gen 3 Magnitude of Transfer Function

For a more thorough overview of PCI Express jitter analysis methodology, please refer to IDT Application Note *PCI Express Reference Clock Requirements*.

Power Considerations

This section provides information on power dissipation and junction temperature for the 831752I. Equations and example calculations are also provided.

1. Power Dissipation.

The total power dissipation for the 831752I is the sum of the core power plus the analog power plus the power dissipated in the load(s). The following is the power dissipation for $V_{DD} = 3.3V + 5\% = 3.465V$, which gives worst case results.

- Power (core)_{MAX} = $V_{DD_MAX} * I_{DD_MAX} = 3.465V * 64mA = 221.76mW$

Power dissipation for the FCLK, nFCLK input internal 50ohm termination. Assume the FCLK, nFCLK input is driven by a HCSL driver. Logic High input current ~ 17mA. Logic low current ~ 0mA.

- Power (input) = $50ohm * (17mA)^2 = 14.45mW$

Total Power_{MAX} (3.465V, with all outputs switching) = $221.76mW + 14.45mW = 236.21mW$

2. Junction Temperature.

Junction temperature, T_j , is the temperature at the junction of the bond wire and bond pad directly affects the reliability of the device. The maximum recommended junction temperature is 125°C. Limiting the internal transistor junction temperature, T_j , to 125°C ensures that the bond wire and bond pad temperature remains below 125°C.

The equation for T_j is as follows: $T_j = \theta_{JA} * Pd_total + T_A$

T_j = Junction Temperature

θ_{JA} = Junction-to-Ambient Thermal Resistance

Pd_total = Total Device Power Dissipation (example calculation is in section 1 above)

T_A = Ambient Temperature

In order to calculate junction temperature, the appropriate junction-to-ambient thermal resistance θ_{JA} must be used. Assuming no air flow and a multi-layer board, the appropriate value is 81.2°C/W per Table 6 below.

Therefore, T_j for an ambient temperature of 85°C with all outputs switching is:

$$85^\circ C + 0.236W * 81.2^\circ C/W = 104.2^\circ C. \text{ This is below the limit of } 125^\circ C.$$

This calculation is only an example. T_j will obviously vary depending on the number of loaded outputs, supply voltage, air flow and the type of board (multi-layer).

Table 6. Thermal Resistance θ_{JA} for 16 Lead TSSOP, Forced Convection

θ_{JA} vs. Air Flow			
Meters per Second	0	1	2.5
Multi-Layer PCB, JEDEC Standard Test Boards	81.2°C/W	73.9°C/W	70.2°C/W

Package Outline and Package Dimensions

Table 7. θ_{JA} vs. Air Flow Table for a 16 Lead TSSOP

θ_{JA} vs. Air Flow			
Meters per Second	0	1	2.5
Multi-Layer PCB, JEDEC Standard Test Boards	81.2°C/W	73.9°C/W	70.2°C/W

Transistor Count

The transistor count for 831752I is: 446

Package Outline and Package Dimensions

Package Outline - G Suffix for 16 Lead TSSOP

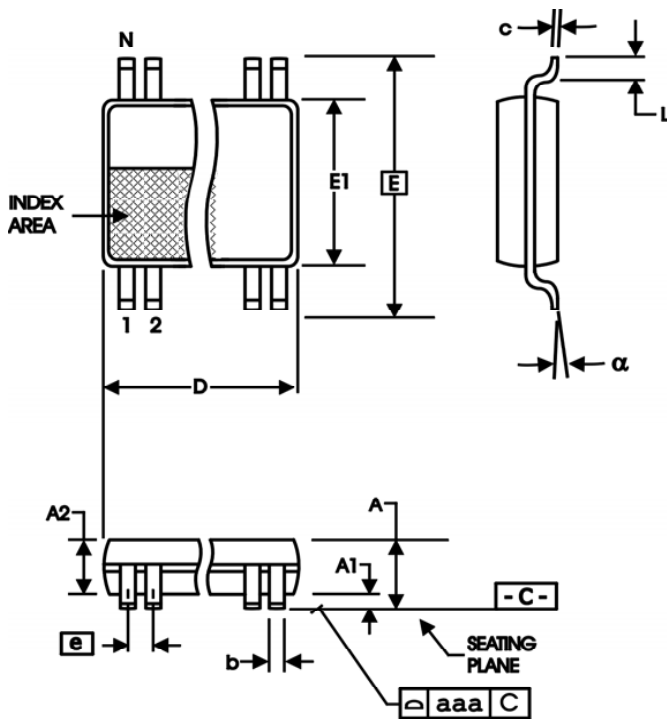

Table 8. Package Dimensions for 16 Lead TSSOP

All Dimensions in Millimeters		
Symbol	Minimum	Maximum
N	16	
A		1.20
A1	0.05	0.15
A2	0.80	1.05
b	0.19	0.30
c	0.09	0.20
D	4.90	5.10
E	6.40 Basic	
E1	4.30	4.50
e	0.65 Basic	
L	0.45	0.75
α	0°	8°
aaa		0.10

Reference Document: JEDEC Publication 95, MO-153

Ordering Information

Table 9. Ordering Information

Part/Order Number	Marking	Package	Shipping Packaging	Temperature
831752AGILF	31752AIL	Lead-Free, 16-lead TSSOP	Tube	-40°C to 85°C
831752AGILFT	31752AIL	Lead-Free, 16-lead TSSOP	Tape & Reel	-40°C to 85°C

Revision History Sheet

Rev	Table	Page	Description of Change	Date
A	9	15	Ordering Information Table - corrected marking	12/20/13
A			Removed ICS from part number where needed. Updated header and footer.	4/5/16
B		1	Block Diagram - corrected labels. Deleted "I" suffix from part number.	6/28/16

IMPORTANT NOTICE AND DISCLAIMER

RENESAS ELECTRONICS CORPORATION AND ITS SUBSIDIARIES (“RENESAS”) PROVIDES TECHNICAL SPECIFICATIONS AND RELIABILITY DATA (INCLUDING DATASHEETS), DESIGN RESOURCES (INCLUDING REFERENCE DESIGNS), APPLICATION OR OTHER DESIGN ADVICE, WEB TOOLS, SAFETY INFORMATION, AND OTHER RESOURCES “AS IS” AND WITH ALL FAULTS, AND DISCLAIMS ALL WARRANTIES, EXPRESS OR IMPLIED, INCLUDING, WITHOUT LIMITATION, ANY IMPLIED WARRANTIES OF MERCHANTABILITY, FITNESS FOR A PARTICULAR PURPOSE, OR NON-INFRINGEMENT OF THIRD PARTY INTELLECTUAL PROPERTY RIGHTS.

These resources are intended for developers skilled in the art designing with Renesas products. You are solely responsible for (1) selecting the appropriate products for your application, (2) designing, validating, and testing your application, and (3) ensuring your application meets applicable standards, and any other safety, security, or other requirements. These resources are subject to change without notice. Renesas grants you permission to use these resources only for development of an application that uses Renesas products. Other reproduction or use of these resources is strictly prohibited. No license is granted to any other Renesas intellectual property or to any third party intellectual property. Renesas disclaims responsibility for, and you will fully indemnify Renesas and its representatives against, any claims, damages, costs, losses, or liabilities arising out of your use of these resources. Renesas' products are provided only subject to Renesas' Terms and Conditions of Sale or other applicable terms agreed to in writing. No use of any Renesas resources expands or otherwise alters any applicable warranties or warranty disclaimers for these products.

(Rev.1.0 Mar 2020)

Corporate Headquarters

TOYOSU FORESIA, 3-2-24 Toyosu,
Koto-ku, Tokyo 135-0061, Japan
www.renesas.com

Contact Information

For further information on a product, technology, the most up-to-date version of a document, or your nearest sales office, please visit:
www.renesas.com/contact/

Trademarks

Renesas and the Renesas logo are trademarks of Renesas Electronics Corporation. All trademarks and registered trademarks are the property of their respective owners.

Mouser Electronics

Authorized Distributor

Click to View Pricing, Inventory, Delivery & Lifecycle Information:

[Renesas Electronics:](#)

[831752AGILF](#)

Looking for pricing, stock, or lifecycle information?

Click below to explore more details on WIN SOURCE:

-  [View 831752AGILFT on WIN SOURCE](#)
-  [Renesas Electronics America](#) Information

Optimize Your Supply Chain with WIN SOURCE Solutions

-  Global Sourcing Solution
-  Obsolete Management
-  Cost Control Management
-  Shortage Management
-  Alternative Solution
-  Excess Inventory Management