



**THE DATASHEET OF
MAX77757JFEG420+T**



MAX77757

3.15A USB Type-C Autonomous Charger with JEITA for 1-Cell Li-ion/LiFePO4 Batteries

General Description

The MAX77757 is a standalone 3.15A charger with integrated USB Type-C® CC detection with JEITA compliance that supports reverse boost capability. The fast-charge current is easily configured with resistors. The MAX77757 operates with an input voltage of 4.5V to 13.7V and has a maximum input current limit of 3A. The IC also implements the adaptive input current limit (AICL) function that regulates the input voltage by reducing input current to prevent the voltage of a weak adapter from collapsing or folding back.

The USB Type-C Configuration Channel (CC) detection pins on the MAX77757 enable automatic USB Type-C power source detection and input current limit configuration. To support a variety of legacy USB types as well as proprietary adapters, the IC also integrates BC1.2 detection using the D+ and D- pins. The IC runs the CC pin and BC1.2 detection automatically as soon as a USB plug is inserted without any software control.

The IC also offers reverse-boost capability up to 5.1V and 1.5A, which can be enabled with the ENBST pin. The STAT pin indicates charging status while the INOKB pin indicates valid input voltage. Charging can be stopped by pulling the THM pin low.

The MAX77757 is equipped with a Smart Power Selector™ and a battery true-disconnect FET to control the charging and discharging of the battery or to isolate the battery in case of a fault. The MAX77757 is offered in several variants to support Li-ion batteries with various termination voltages from 4.1V to 4.5V. It also has a 3.6V termination voltage option for LiFePO₄ batteries. The IC comes in a 3mm x 3mm, 0.4mm pitch, 24-lead FC2QFN package making it suitable for low-cost PCB assembly.

Applications

- Mobile Point-of-Sale (mPOS) Terminals
- Portable Medical Devices
- Wireless Headphones
- GPS Trackers
- Charging Cradles for Wearable Devices
- Power Banks
- Mobile Routers

Benefits and Features

- Up to 16V Protection
- 13.7V Maximum Input Operating Voltage
- 3.15A Maximum Charging Current
- 6A Discharge Current Protection
 - No Firmware or Communication Required
 - Integrated CC Detection for USB Type-C
 - Integrated BC1.2 Detection for Legacy SDP, DCP, CDP, and DCD Timeout
 - Integrated USB Detection for Common Proprietary Charger Types
 - Automatic Input Current Limit Configuration
 - Input Voltage Regulation with Adaptive Input Current Limit (AICL)
- Reverse Boost Capability up to 5.1V, 1.5A
- Termination Voltage
 - 4.1V to 4.5V for Li-ion and Li-poly Batteries
 - 3.6V/3.7V for LiFePO₄ Battery
- Safety
 - Charge Safety Timer
 - JEITA Compliance with NTC Thermistor (MAX77757J)
 - HOT/COLD Stop Charging with NTC Thermistor (MAX77757H)
 - Thermal Shutdown
- Pin Control of All Functions
 - Resistor Configurable Fast-Charge Current
 - ENBST Pin to Enable and Disable Reverse Boost
 - STAT Pin to Indicate Charging Status
 - INOKB Pin to Indicate Input Power-OK
 - THM Pin to Disable Charge
- Integrated Power Path
- Integrated Battery True-Disconnect FET
- 3mm x 3mm, 24-Lead FC2QFN Package

Ordering Information appears at end of data sheet.

Simplified Block Diagram

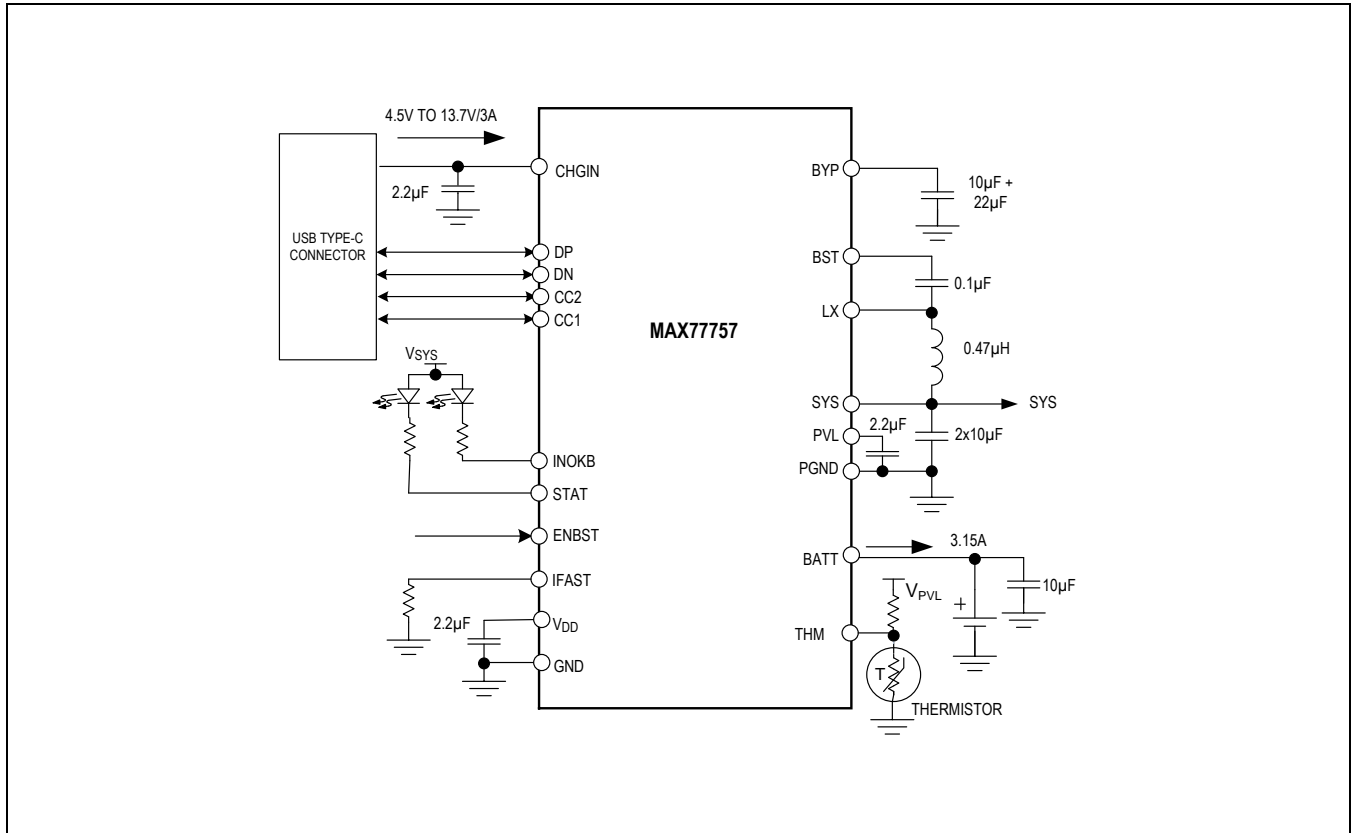

Absolute Maximum Ratings

CHGIN to GND.....	-0.3V to +16.0V	V _{DD} , PVL, IFAST, THM to GND.....	-0.2V to +2.2V
BYP, LX to PGND	-0.3V to +16.0V	V _{CHGIN} , BYP Continuous Current	3.2A _{RMS}
BATT, SYS, INOKB, STAT, ENBST to GND	-0.3V to +6.0V	LX, PGND Continuous Current	3.5A _{RMS}
BST to PVL.....	-0.3V to +16.0V	SYS, BATT Continuous Current.....	4.5A _{RMS}
BST to LX.....	-0.3V to +2.2V	Operating Temperature Range	-40°C to +85°C
DN, DP to GND	-0.3V to +6.0V	Storage Temperature Range	-65°C to +150°C
CC1, CC2 to GND	-0.3V to +6.0V		

Stresses beyond those listed under "Absolute Maximum Ratings" may cause permanent damage to the device. These are stress ratings only, and functional operation of the device at these or any other conditions beyond those indicated in the operational sections of the specifications is not implied. Exposure to absolute maximum rating conditions for extended periods may affect device reliability.

Package Information

24-Lead FC2QFN

Package Code	F243A3F+1
Outline Number	21-100385B
Land Pattern Number	90-100128A
Thermal Resistance, Four-Layer Board:	
Junction-to-Ambient (θ_{JA})	31°C/W
Junction-to-Case Thermal Resistance (θ_{JC})	7.5°C/W

For the latest package outline information and land patterns (footprints), go to www.maximintegrated.com/packages. Note that a "+", "#", or "-" in the package code indicates RoHS status only. Package drawings may show a different suffix character, but the drawing pertains to the package regardless of RoHS status.

Package thermal resistances were obtained using the method described in JEDEC specification JESD51-7, using a four-layer board. For detailed information on package thermal considerations, refer to www.maximintegrated.com/thermal-tutorial.

Electrical Characteristics

(Limits are 100% tested at T_A = +25°C. Limits over the operating temperature range and relevant supply voltage range are guaranteed by design and characterization.)

PARAMETER	SYMBOL	CONDITIONS	MIN	TYP	MAX	UNITS
GENERAL ELECTRICAL CHARACTERISTICS						
Battery Only Quiescent Current	I _{BATT_Q}	USBC as UFP and BATT = SYS = 3.6V		30	50	μA
SWITCHING MODE CHARGER						
CHGIN Voltage Range	V _{CHGIN}	Operating voltage (Note 1)	V _{CHGIN_UVLO}		V _{CHGIN_OVLO}	V
CHGIN Overvoltage Threshold	V _{CHGIN_OVLO}	V _{CHGIN} rising	13.4	13.7	14	V
CHGIN Overvoltage-Threshold Hysteresis	V _{CHGINH_OVLO}	V _{CHGIN} falling		300		mV
CHGIN to GND Minimum Turn-On Threshold Accuracy	V _{CHGIN_UVLO}	V _{CHGIN} rising	4.6	4.7	4.8	V
CHGIN to SYS Minimum Turn-On Threshold	V _{CHGIN2SYS}	V _{CHGIN} rising	V _{SYS} + 0.12	V _{SYS} + 0.20	V _{SYS} + 0.28	V

(Limits are 100% tested at $T_A = +25^\circ\text{C}$. Limits over the operating temperature range and relevant supply voltage range are guaranteed by design and characterization.)

PARAMETER	SYMBOL	CONDITIONS	MIN	TYP	MAX	UNITS
CHGIN Adaptive Voltage Regulation Threshold Accuracy	$V_{\text{CHGIN_REG}}$		4.4	4.5	4.6	V
CHGIN Current Limit Range	CHGIN_ILIM	Automatically configured after charger type detection	0.5		3.0	A
CHGIN Supply Current	I_{IN}	$V_{\text{CHGIN}} = 5.0\text{V}$, charger enabled, $V_{\text{SYS}} = V_{\text{BATT}} = 4.5\text{V}$, (no switching, battery charged)		2.7	4	mA
V_{CHGIN} Input Current Limit	I_{INLIMIT}	Charger enabled, 500mA input current setting	423	460	500	mA
		Charger enabled, 1500mA input current setting	1300	1400	1500	
		Charger enabled, 3000mA input current setting	2600	2800	3000	
CHGIN Self-Discharge Down to UVLO Time	t_{INSD}	Time required for the charger input to cause CHGIN capacitor to decay from 6.0V to 4.3V		100		ms
CHGIN Input Self-Discharge Resistance	R_{INSD}			44		k Ω
CHGIN to BYP Resistance	$R_{\text{CHGIN2BYP}}$	Bidirectional		21.5		m Ω
LX High-Side Resistance	R_{HS}			44		m Ω
LX Low-Side Resistance	R_{LS}			42		m Ω
BATT to SYS Dropout Resistance	R_{BAT2SYS}			13		m Ω
CHGIN to BATT Dropout Resistance	$R_{\text{CHGIN2BAT}}$	Calculation estimates a 0.04 Ω inductor resistance (R_L) $R_{\text{CHGIN2BAT}} = R_{\text{CHGIN2BYP}} + R_{\text{HS}} + R_L + R_{\text{BAT2SYS}}$		118.5		m Ω
LX Leakage Current		LX = PGND or BYP, $T_A = +25^\circ\text{C}$		0.01	10	μA
		LX = PGND or BYP, $T_A = +85^\circ\text{C}$		1		
BST Leakage Current		BST = PGND or 1.8V, $T_A = +25^\circ\text{C}$		0.01	10	μA
		BST = PGND or 1.8V, $T_A = +85^\circ\text{C}$		1		
BYP Leakage Current		$V_{\text{BYP}} = 5\text{V}$, $V_{\text{CHGIN}} = 0\text{V}$, LX = 0V, charger disabled, $T_A = +25^\circ\text{C}$		0.01	10	μA
		$V_{\text{BYP}} = 5\text{V}$, $V_{\text{CHGIN}} = 0\text{V}$, LX = 0V, charger disabled, $T_A = +85^\circ\text{C}$		1		
SYS Leakage Current		$V_{\text{SYS}} = 0\text{V}$, $V_{\text{BATT}} = 4.2\text{V}$, charger disabled, $T_A = +25^\circ\text{C}$		0.01	10	μA
		$V_{\text{SYS}} = 0\text{V}$, $V_{\text{BATT}} = 4.2\text{V}$, charger disabled, $T_A = +85^\circ\text{C}$		1		
Minimum ON Time	$t_{\text{ON-MIN}}$			75		ns
Minimum OFF Time	$t_{\text{OFF-MIN}}$			75		ns
Buck Current Limit	I_{LIM}		5.16	6.0	6.84	A

(Limits are 100% tested at $T_A = +25^\circ\text{C}$. Limits over the operating temperature range and relevant supply voltage range are guaranteed by design and characterization.)

PARAMETER	SYMBOL	CONDITIONS	MIN	TYP	MAX	UNITS
Reverse Boost Quiescent Current		Non-switching; output forced 200mV above its target regulation voltage		2000		μA
Reverse Boost BYP Voltage in OTG Mode	$V_{\text{BYP.OTG}}$		4.94	5.1	5.26	V
CHGIN Output Current Limit	$I_{\text{CHGIN.OTG.LIM}}$	$3.4\text{V} < V_{\text{BATT}} < 4.5\text{V}$	1500		1725	mA
Reverse Boost Output Voltage Ripple		Discontinuous inductor current (i.e., skip mode)		± 150		mV
		Continuous inductor current		± 150		
BATT Regulation Voltage Accuracy		$T_A = +25^\circ\text{C}$, BATT regulation voltage (See the Ordering Information table)	-0.9	-0.3	+0.3	%
		$T_A = 0^\circ\text{C}$ to $+85^\circ\text{C}$, BATT regulation voltage (See the Ordering Information table)	-1	-0.3	+0.5	
Fast-Charge Current Program Range		External resistor programmable	0.5		3.15	A
Fast-Charge Currents	I_{FC}	$V_{\text{BATT}} > V_{\text{SYSMIN}}$, programmed for 3.0A	2850	3000	3150	mA
		$V_{\text{BATT}} > V_{\text{SYSMIN}}$, programmed for 2.0A	1900	2000	2100	
		$V_{\text{BATT}} > V_{\text{SYSMIN}}$, programmed for 0.5A	465	500	535	
Trickle Charge Threshold	V_{TRICKLE}	V_{BATT} rising for termination voltage from 4.1V to 4.5V; trickle charge is disabled for 3.6V option	3.0	3.1	3.2	V
Precharge Threshold	V_{PRECHG}	V_{BATT} rising	2.4	2.5	2.6	V
Prequalification Threshold Hysteresis	$V_{\text{PQ-H}}$	Applies to both V_{TRICKLE} and V_{PRECHG}		100		mV
Trickle Charge Current	I_{TRICKLE}	I_{TRICKLE} for termination voltage from 4.1V to 4.5V option; trickle charge is disabled for 3.6V option	270	300	330	mA
Precharge Charge Current	I_{PRECHG}		40	55	80	mA
Charger Restart Threshold	V_{RSTRT}		50	100	150	mV
Charger Restart Deglitch Time		10mV overdrive, 100ns rise time		130		ms
Top-Off Current Program Range	I_{TO}	See Table 3	50		150	mA
Top-Off Current Accuracy	I_{TO}	Programmed for 150mA	130	150	170	mA
		Programmed for 50mA	25	50	75	
Charge Termination Deglitch Time	t_{TERM}	2mV overdrive, 100ns rise/fall time		30		ms
Charger Soft-Start Time	t_{SS}			1.5		ms
BATT to SYS Reverse Regulation Voltage	V_{BSREG}	$I_{\text{BATT}} = 10\text{mA}$		70		mV
		Load regulation during the reverse regulation mode		1		mV/A
Minimum SYS Voltage	V_{SYSMIN}	For termination voltage from 4.1V to 4.5V		3.5		V
		For 3.6V termination voltage		3.0		

(Limits are 100% tested at $T_A = +25^\circ\text{C}$. Limits over the operating temperature range and relevant supply voltage range are guaranteed by design and characterization.)

PARAMETER	SYMBOL	CONDITIONS	MIN	TYP	MAX	UNITS
Minimum SYS Voltage Accuracy	V_{SYSMIN}		-3		+3	%
Prequalification Time	t_{PQ}	Applies to both low-battery precharge and trickle modes		30		min
Fast-Charge Constant Current Plus Fast-Charge Constant Voltage Time	t_{FC}			6		h
Top-Off Time	t_{TO}			30		s
Timer Accuracy			-20		+20	%
Junction Temperature Thermal Regulation Loop Setpoint Program Range	T_{REG}	Junction temperature when charge current is reduced		130		$^\circ\text{C}$
Thermal Regulation Gain	AT_{JREG}	$I_{\text{FC}} = 3.15\text{A}$		-157.5		$\text{mA}/^\circ\text{C}$
THM Threshold, COLD	THM_COLD	$V_{\text{THM}}/V_{\text{PVL}}$ rising, 1% hysteresis (thermistor temperature falling)	72.5	74	75.5	%
THM Threshold, COOL	THM_COOL	$V_{\text{THM}}/V_{\text{PVL}}$ rising, 1% hysteresis (thermistor temperature falling)	63.5	65	66.5	%
THM Threshold, WARM	THM_WARM	$V_{\text{THM}}/V_{\text{PVL}}$ falling, 1% hysteresis (thermistor temperature rising)	31	32.5	34	%
THM Threshold, HOT	THM_HOT	$V_{\text{THM}}/V_{\text{PVL}}$ falling, 1% hysteresis (thermistor temperature rising)	21.5	23	24.5	%
Charger Disable Threshold	$V_{\text{CHGR_EN}}$	$V_{\text{THM}}/V_{\text{PVL}}$ falling, 1% hysteresis (charger is disabled below this threshold)	4.5	6	7.5	%
THM Input Leakage Current		$V_{\text{THM}} = \text{GND}$ or V_{PVL} ; $T_A = +25^\circ\text{C}$		0.1	1	μA
		$V_{\text{THM}} = \text{GND}$ or V_{PVL} ; $T_A = +85^\circ\text{C}$		0.1		μA
Battery Overcurrent Threshold	I_{BOVCR}			6.0		A
Battery Overcurrent Debounce Time	t_{BOVRC}		6			ms
Battery Overcurrent Retry	$t_{\text{OCP_RETRY}}$			0.15		s
Battery Overcurrent Protection Quiescent Current	I_{BOVRC}			$3 + I_{\text{BATT}}/18040$		μA
System Power-Up Current	I_{SYSPU}		35	50	80	mA
System Power-Up Voltage	V_{SYSPU}	V_{SYS} rising, 100mV hysteresis	1.9	2.0	2.1	V
INOKB, STAT						
Logic Input Leakage Current				0.1	1	μA

(Limits are 100% tested at $T_A = +25^\circ\text{C}$. Limits over the operating temperature range and relevant supply voltage range are guaranteed by design and characterization.)

PARAMETER	SYMBOL	CONDITIONS	MIN	TYP	MAX	UNITS
Output Low Voltage INOKB, STAT		$I_{\text{source}} = 5\text{mA}$			0.4	V
Output High Leakage INOKB, STAT		$V_{\text{SYS}} = 5.5\text{V}$, $T_A = +25^\circ\text{C}$	-1	0	+1	μA
		$V_{\text{SYS}} = 5.5\text{V}$, $T_A = +85^\circ\text{C}$		0.1		
ENBST						
ENBST Logic Input Low Threshold	V_{IL}				0.4	V
ENBST Logic Input High Threshold	V_{IH}		1.4			V
ENBST Logic Input Leakage Current	I_{ENBST}	ENBST = 5.5V (including current through pulldown resistor)		24	60	μA
ENBST Pulldown Resistor	R_{ENBST}			235		$\text{k}\Omega$
CHARGER DETECTION						
BC1.2 State Timeout	t_{TMO}		180	200	220	ms
Data Contact Detect Time-Out	t_{DCDtmO}		700	800	900	ms
Proprietary Charger Debounce	t_{PRDeb}		5	7.5	10	ms
Primary to Secondary Timer	t_{PDSWait}		27	35	39	ms
Charger Detection Debounce	t_{CDDeb}		45	50	55	ms
VBUS64 Threshold	V_{BUS64}	DP and DN pins; threshold in percent of V_{BUS} voltage $3\text{V} < V_{\text{BUS}} < 5.5\text{V}$	57	64	71	%
VBUS64 Hysteresis	$V_{\text{BUS64_H}}$			0.015		V
VBUS47 Threshold	V_{BUS47}	DP and DN pins; threshold in percent of V_{BUS} voltage $3\text{V} < V_{\text{BUS}} < 5.5\text{V}$	43.3	47	51.7	%
VBUS47 Hysteresis				0.015		V
VBUS31 Threshold	V_{BUS31}	DP and DN pins; threshold in percent of V_{BUS} voltage $3\text{V} < V_{\text{BUS}} < 5.5\text{V}$	26	31	36	%
VBUS31 Hysteresis				0.015		V
IWEAK Current	I_{WEAK}		0.01	0.1	0.5	μA
RDM_DWN Resistor	$R_{\text{DM_DWN}}$		14.25	20	24.8	$\text{k}\Omega$
IDP_SRC Current	$I_{\text{DP_SRC}}/I_{\text{DCD}}$	Accurate over 0V to 2.5V	7	10	13	μA
IDM_SINK Current	$I_{\text{DM_SINK}}/I_{\text{DATSINK}}$	Accurate over 0.15V to 3.6V	45	80	125	μA

(Limits are 100% tested at $T_A = +25^\circ\text{C}$. Limits over the operating temperature range and relevant supply voltage range are guaranteed by design and characterization.)

PARAMETER	SYMBOL	CONDITIONS	MIN	TYP	MAX	UNITS
VLGC Threshold	V_{LGC}		1.62	1.7	1.9	V
VLGC Hysteresis	V_{LGC_H}			0.015		V
VDAT_REF Threshold	V_{DAT_REF}		0.25	0.32	0.4	V
VDAT_REF Hysteresis	$V_{DAT_REF_H}$			0.015		V
VDN_SRC Voltage	$V_{DN_SRC}/$ V_{SRC06}	Accurate over $I_{LOAD} = 0$ to $200\mu\text{A}$	0.5	0.6	0.7	V
VDP_SRC Voltage	$V_{DP_SRC}/$ V_{SRC06}	Accurate over $I_{LOAD} = 0$ to $200\mu\text{A}$	0.5	0.6	0.7	V
COMP2 Load Resistor	R_{USB}	Load resistor on DP/DN	3	6.1	12	$\text{M}\Omega$
CC DETECTION						
CC Pin Voltage in DFP 1.5A Mode	V_{CC_PIN}	Measured at CC pins with $126\text{k}\Omega$ load; IDFP1.5_CC enable and $V_{AVL} \geq 2.5\text{V}$	1.85			V
CC Pin Clamp Voltage	V_{CC_CIAMP}	$60\mu\text{A} \leq I_{CC} \leq 600\mu\text{A}$		1.1	1.32	V
CC Pin Clamp Voltage (5.5V)		$I_{CC} < 2\text{mA}$		5.25	5.5	V
CC UFP Pulldown Resistance	R_{PD_UFP}		-10%	5.1K	+10%	Ω
CC DFP 1.5A Current Source	$I_{DFP1.5_CC}$		-8%	180	+8%	μA
CC RA RD Threshold	$V_{RA_RD0.5}$		0.15	0.2	0.25	V
CC UFP 0.5A RD Threshold	$V_{UFP_RD0.5}$		0.61	0.66	0.7	V
CC UFP 0.5A RD Hysteresis	$V_{UFP_RD0.5_H}$			0.015		V
CC UFP 1.5A RD Threshold	$V_{UFP_RD1.5}$		1.16	1.23	1.31	V
CC UFP 1.5A RD Hysteresis	$V_{UFP_RD1.5_H}$			0.15		V
CC Pin Power-Up Time	$t_{ClampSwap}$	Max time allowed from removal of voltage clamp till $5.1\text{k}\Omega$ resistor attached			15	ms
CC Detection Debounce	t_{CCDeb}		100	119	200	ms
Type-C Debounce	t_{PDDeb}		10	15	20	ms
Type-C Quick Debounce	t_{QDeb}		0.9	1	1.1	ms

Note 1: The CHGIN input must be less than V_{CHGIN_OVLO} and greater than both V_{CHGIN_UVLO} and $V_{CHGIN2SYS}$ for the charger to turn on.

Pin Configuration

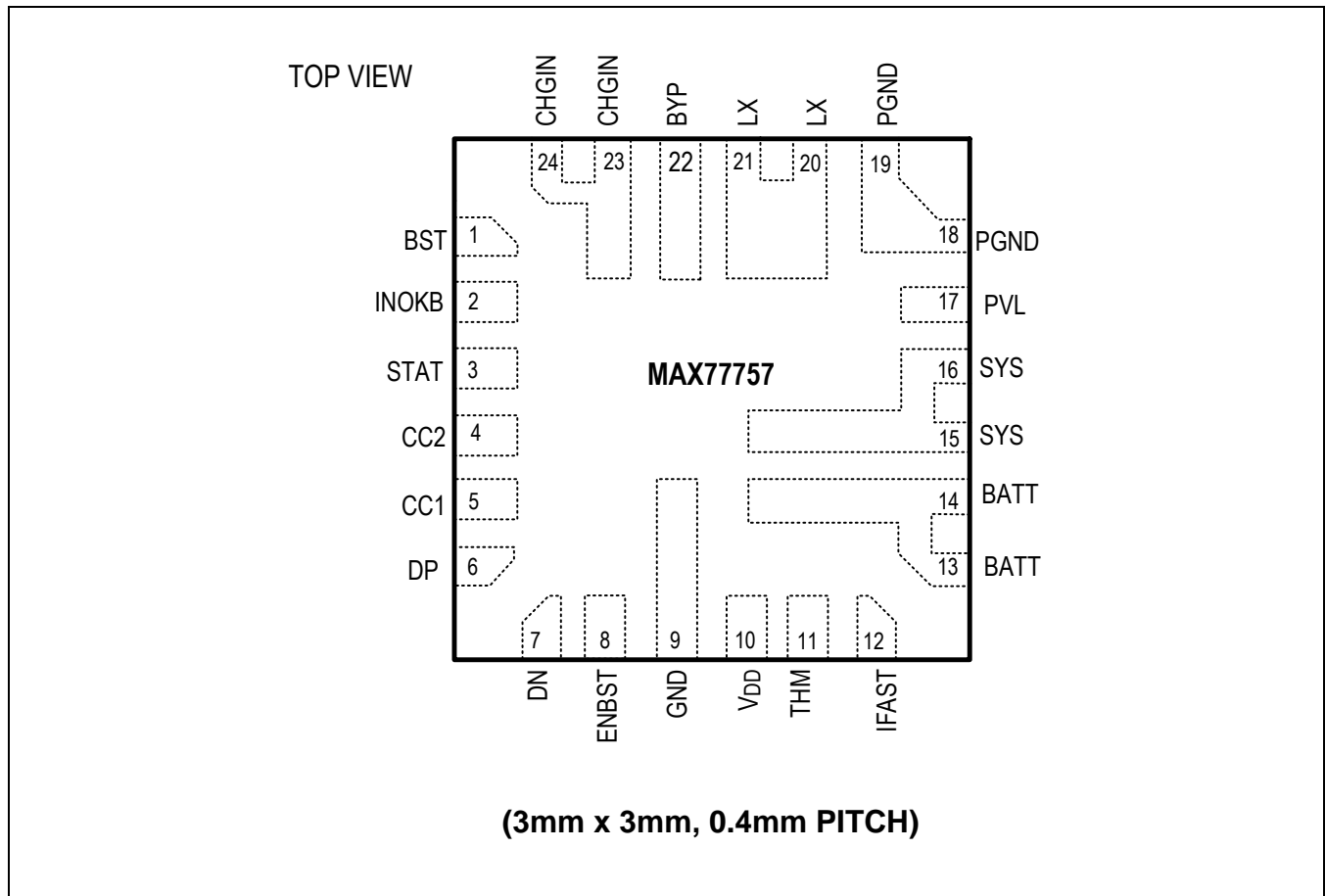

Pin Descriptions

PIN	NAME	FUNCTION
1	BST	Provides Drive To High-Side Internal nMOS. Connect a 0.1µF/6.3V bootstrap capacitor between this pin and the LX node.
2	INOKB	Charger Input Valid, Active-Low Logic Output Flag. Open-drain output indicates when valid voltage is present at CHGIN.
3	STAT	Open-Drain Charge Status Indication Output. STAT is toggling low and high impedance during charge. STAT becomes low when top-off threshold is detected and in done state. STAT becomes high impedance when charge faults happen.
4	CC2	USB Type-C CC2 Connection
5	CC1	USB Type-C CC1 Connection
6	DP	Common Positive Output 1. Connect to D+ on USB Type-C or micro-USB connector.
7	DN	Common Negative Output 1. Connect to D- on USB Type-C or micro-USB connector.
8	ENBST	Active-High Logic Input. Enable/disable the reverse boost converter.
9	GND	Analog Ground. Short to ground plane.
10	VDD	Output of On-Chip LDO Used to Power On-Chip, Low-Noise Circuits. Bypass with a 2.2µF/10V ceramic capacitor to GND. Powering external loads from V _{DD} is not recommended other than pullup resistors.

11	THM	Thermistor Connection. Connect an external negative temperature coefficient (NTC) thermistor from THM to GND. Connect a resistor equal to the thermistor +25°C resistance from THM to PVL.
12	IFAST	Fast-Charge Current Setting Pin. Connect a resistor (RIFAST) from IFAST to GND to program the fast charge current. Use 24.9kΩ for 3.15A fast charge current. See the Application Information section.
13, 14	BATT	Battery Power Connection. Connect to the positive terminal of a single-cell (or parallel cell) Li-ion battery. Bypass BATT to PGND ground plane with a 10μF ceramic capacitor.
15, 16	SYS	System Power Node. Bypass SYS to PGND with a 2x10μF/10V ceramic capacitor.
17	PVL	Output of On-Chip LDO, Noisy Rail due to Bootstrap Operation. Bypass with a 2.2μF/10V ceramic capacitor to PGND. Powering external loads from PVL is not recommended.
18, 19	PGND	Power Ground. Connect the return of the buck output capacitor close to these pins.
20, 21	LX	Switching Node. Connect an inductor between LX and SYS. When the buck converter is enabled, LX switches between BYP and PGND to control the input current, battery current, battery voltage, and die temperature.
22	BYP	System Power Connection. Output of OVP adapter input block and input to switching charger. Bypass with a 22μF/16V ceramic capacitor from BYP to PGND.
23, 24	CHGIN	Charger Input. Up to 13.7V operating, 16VDC withstand input pin connected to an adapter or USB power source. Connect a 2.2μF/16V ceramic capacitor from CHGIN to GND.

Functional Diagram

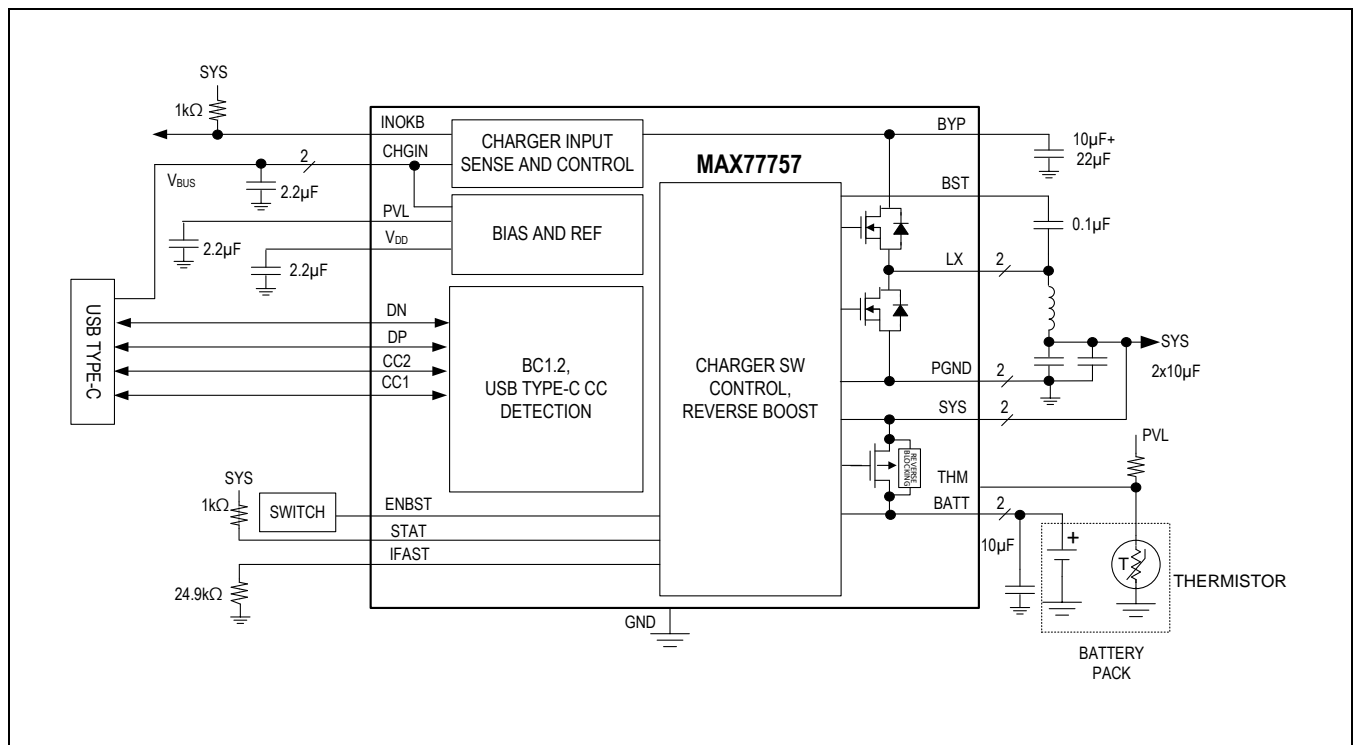

Detailed Description

The MAX77757 is a highly integrated USB Type-C Charger with autonomous configuration. The MAX77757 can operate from an input range of 4.5V to 13.7V to support 5V, 9V, and 12V AC adapters as well as USB input. The fast-charge current is up to 3.15A and the max input current limit is 3.0A.

The MAX77757 can run BC1.2 and USB Type-C CC detection upon input insertion and configure input source to max power option and charger input current limit to max power.

Fast-charge current and top-off current threshold can be programmed with an external resistor. The input voltage regulation feature (AICL) even allows users to use weak AC adapters without preventing a charge.

The power path design provides system power even when the battery is fully discharged, and it supplements current from the battery and charge input automatically when the system demands a higher current.

A reverse boost from the battery can be enabled by the ENBST pin to allow 5.1V/1.5A OTG to V_{BUS} .

Switching Mode Charger

Features

- Complete Li+/LiPoly/LiFePO₄ Battery Charger
 - Prequalification, Constant Current, Constant Voltage
 - 55mA Precharge Current
 - 300mA Trickle Charge Current for Charge Termination Voltage from 4.1V to 4.5V. For the 3.6V/3.7V Termination Voltage Options, Trickle Charge Current is Disabled
 - Resistor Adjustable Constant Current Charge
 - 500mA to 3.15A
 - Resistor Adjustable Charge Termination Threshold
 - 50mA to 150mA
 - Battery Regulation Voltage
 - 3.60V, 4.20V, 4.35V, and 4.40V
 - -0.9/+0.3% Accuracy at +25°C
 - -1/+0.5% Accuracy from 0°C to +85°C
- Synchronous Switch-Mode Based Design
- Smart Power Selector
 - Optimally Distributes Power Between the Charge Adapter, System, and Main Battery
 - When Powered by a Charge Adapter, the Main Battery can Provide Supplemental Current to the System
 - The Charge Adapter can Support the System without the Main Battery
- No External MOSFETs Required
- Single Input Operation
 - Reverse Leakage Protection (Prevents the Battery from Leaking Current to the Inputs)
 - $V_{CHGIN_OVLO} = 13.7V$
 - Supports AC-to-DC Wall Adapters
 - Automatic Input Current Limit Selection After Charger Type Detection
 - 500mA, 1A, 2A, 2.5A, and 3A
- Charge Safety Timer
 - 6 Hours
- Die Temperature Monitor with Thermal Foldback Loop
 - Die Temperature Thresholds: 130°C
- Input Voltage Regulation Allows Operation from High-Impedance Sources (AICL)
- BATT to SYS Switch is 20mΩ Typical
 - Capable of 4.5A Steady-State Operation from BATT to SYS
- Short Circuit Protection
 - BATT to SYS Overcurrent Threshold: 6A
 - SYS Short-to-Ground
 - Buck Operates with Input Current Limit to 200mA when $V_{SYS} < V_{SYSPU}$

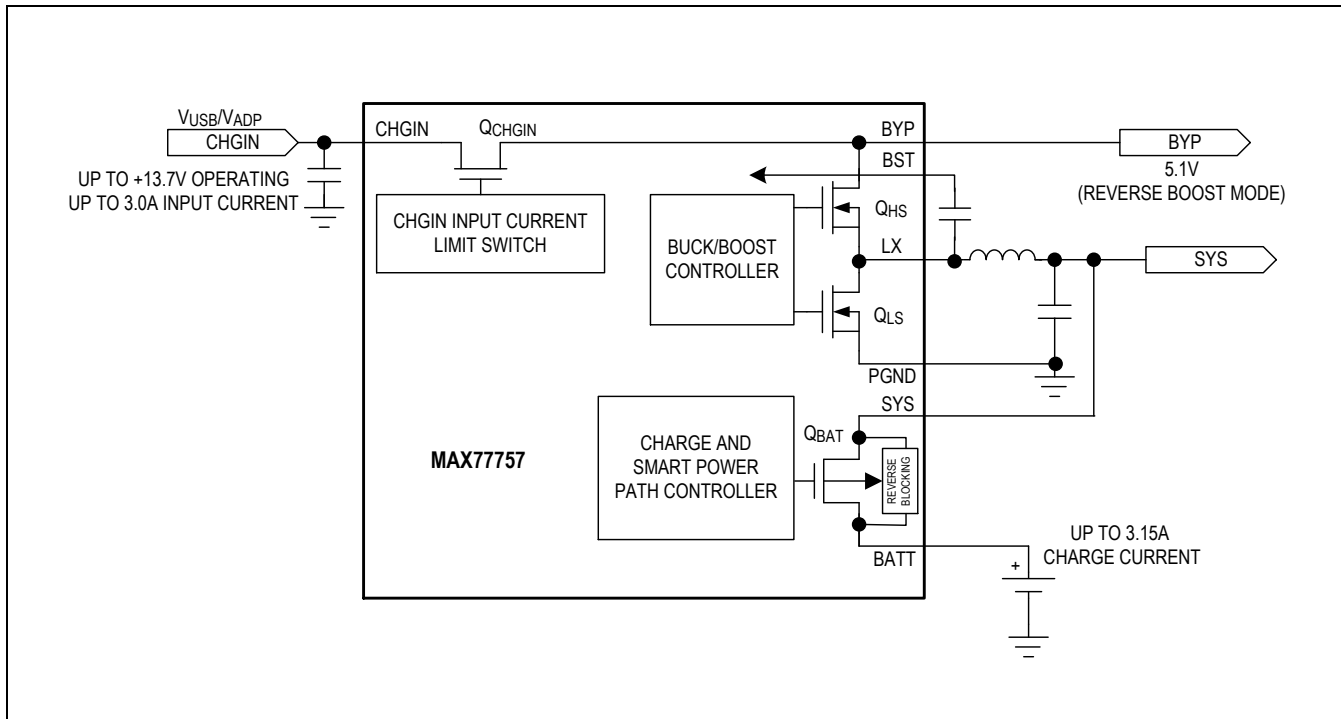

Figure 1. Simplified Functional Diagram

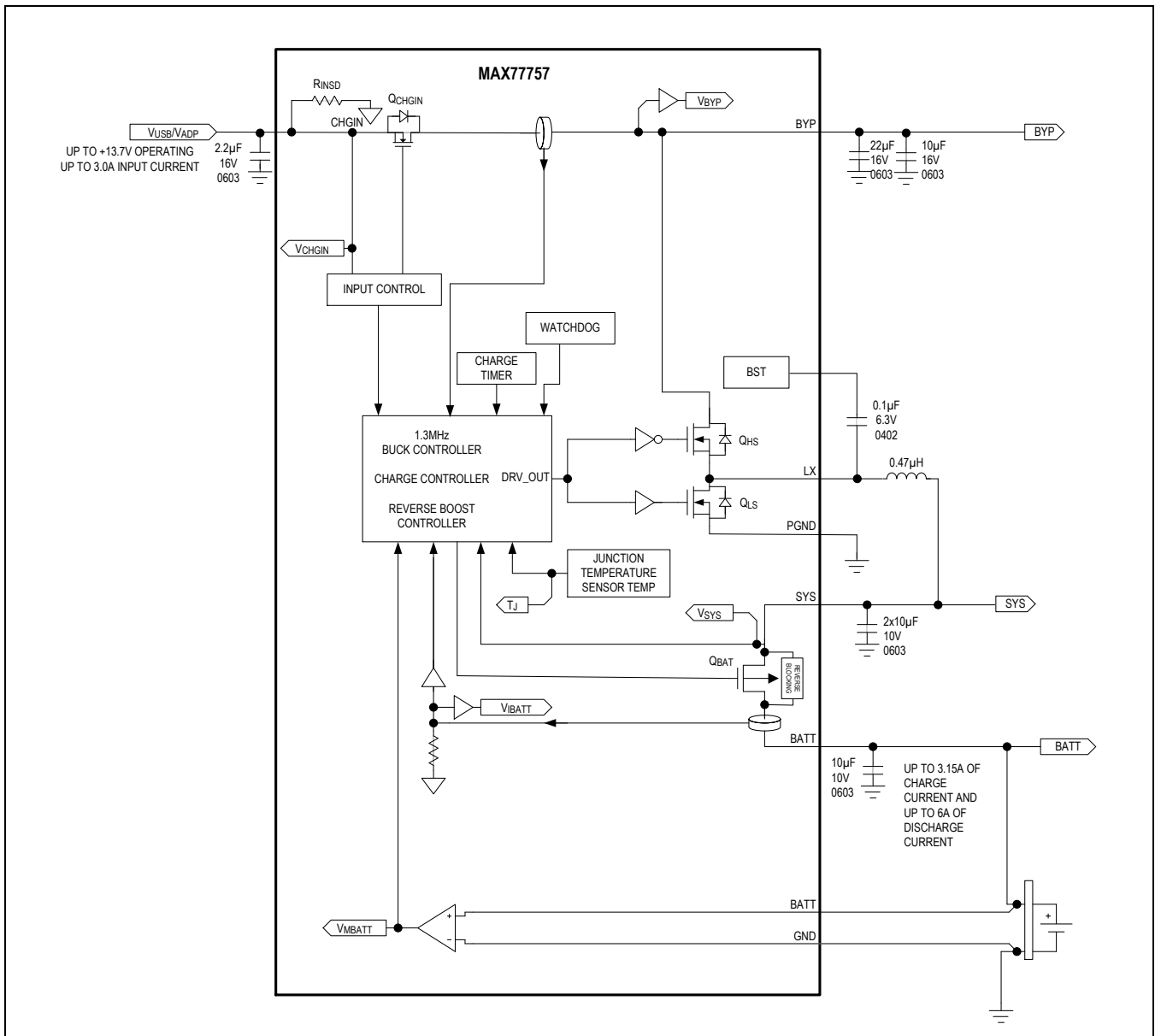

Figure 2. Main Battery Charger Detailed Functional Diagram

Detailed Description

The MAX77757 is a switch-mode charger for a one-cell lithium-ion (Li+), lithium polymer (Li-polymer), or LiFePO₄ battery. The current limit for CHGIN input is configured automatically allowing the flexibility to connect to either an AC-to-DC wall charger or a USB port, as shown in [Figure 2](#).

The synchronous switch-mode DC-DC converter utilizes a high 1.3MHz switching frequency, which is ideal for portable devices since it allows the use of small components while eliminating excessive heat generation. The DC-DC converter has both a buck and a boost mode of operation. When charging, the main battery converter operates in buck mode. The DC-DC buck operates from a 4.3V to 13.7V source and delivers up to 3.15A to the battery. The battery charge current is programmable from 500mA to 3.15A with an external resistor.

As a boost converter, the DC-DC uses energy from the main battery to boost the voltage at BYP. The boosted BYP voltage is used to supply the USB OTG voltage which is fixed to 5.1V.

Maxim Integrated's Smart Power Selector architecture makes the best use of the limited adapter power and the battery's power at all times to supply up to buck current limit from the buck to the system. (Additionally, supplement mode provides additional current from the battery to the system up to B2SOVRC.) Adapter power that is not used for the system is used to charge the battery. All power switches for charging and switching the system load between the battery and adapter power are included on-chip—no external MOSFETs are required.

Maxim Integrated's proprietary process technology allows for low-RDSON devices in a small solution size. The total dropout resistance from the adapter power input to the battery is 165mΩ (typ), assuming that the inductor has 0.04Ω of ESR. This 165mΩ typical dropout resistance allows for charging a battery up to 3.0A from a 5V supply. The resistance from the BATT-to-SYS node is 20mΩ, allowing for low power dissipation and long battery life.

A multitude of safety features ensures reliable charging. Features include a charge timer, junction thermal regulation, over/undervoltage protection, and short circuit protection.

The BATT-to-SYS switch has overcurrent protection (see the [Main Battery Overcurrent Protection During System Power-Up](#) section for more information).

Smart Power Selector (SPS)

The SPS architecture is a network of internal switches and control loops that distribute energy between external power sources CHGIN, BYP, SYS, and BATT.

[Figure 1](#) shows a simplified arrangement for the smart power selector's power steering switches. [Figure 2](#) shows a more detailed arrangement of the smart power selector switches with the following names: Q_{CHGIN}, Q_{HS}, Q_{LS}, and Q_{BAT}.

Switch and Control Loop Descriptions

- CHGIN Input Switch: Q_{CHGIN} provides the input overvoltage protection of +16V. The input switch is either completely on or completely off. As shown in [Figure 2](#), there are SPS control loops that monitor the current through the input switches as well as the input voltage.
- DC-DC Switches: Q_{HS} and Q_{LS} are the DC-DC switches that can operate as a buck (step-down) or a boost (step-up). When operating as a buck, energy is moved from BYP to SYS. When operating as a boost, energy is moved from SYS to BYP. SPS control loops monitor the DC-DC switch current, the SYS voltage, and the BYP voltage.
- Battery-to-System Switch: Q_{BAT} controls the battery charging and discharging. Additionally, Q_{BAT} allows the battery to be isolated from the system (SYS). An SPS control loop monitors the Q_{BAT} current.

SYS Regulation Voltage

- When DC-DC is enabled as a buck and the charger is enabled but in a non-charging state such as done, thermal shutdown, or timer fault, V_{SYS} is regulated to V_{BATTREG} and Q_{BAT} is off.
- When the DC-DC is enabled as a buck and charging in trickle-charge, fast-charge, or top-off modes, V_{SYS} is regulated to V_{SYSMIN} when the V_{PRECHG} < V_{BATT} < V_{SYSMIN}. And, when the DC-DC is enabled as a buck and charging in precharge mode (V_{BATT} < V_{PRECHG}), V_{SYS} is regulated to V_{BATTREG}. In these modes, the Q_{BAT} switch acts as a linear regulator and dissipates power ($P = (V_{SYS} - V_{BATT}) \times I_{BATT}$). When V_{BATT} > V_{SYSMIN}, then V_{SYS} = V_{BATT} + I_{BATT} × R_{BAT2SYS}. In this mode, the Q_{BAT} switch is closed.

In all of the previous modes, if the combined SYS load exceeds the input current limit, then V_{SYS} drops to V_{BATT} – V_{BSREG}, and the battery provides supplemental current.

Input Validation

The charger input is compared with several voltage thresholds to determine if it is valid. A charger input must meet the following three characteristics to be valid:

- CHGIN must be above V_{CHGIN_UVLO} to be valid. Once CHGIN is above the UVLO threshold, the information (together with LIN2SYS, described as follows) is latched and only can be reset when the charger is in adaptive input current loop (AICL) and input current is lower than the IULO threshold of 60mA. Note that V_{CHGIN_REG} is lower than their UVLO falling threshold, respectively.

- CHGIN must be below its overvoltage lockout threshold (V_{CHGIN_OVLO}).
- CHGIN must be above the system voltage by $V_{CHGIN2SYS}$.

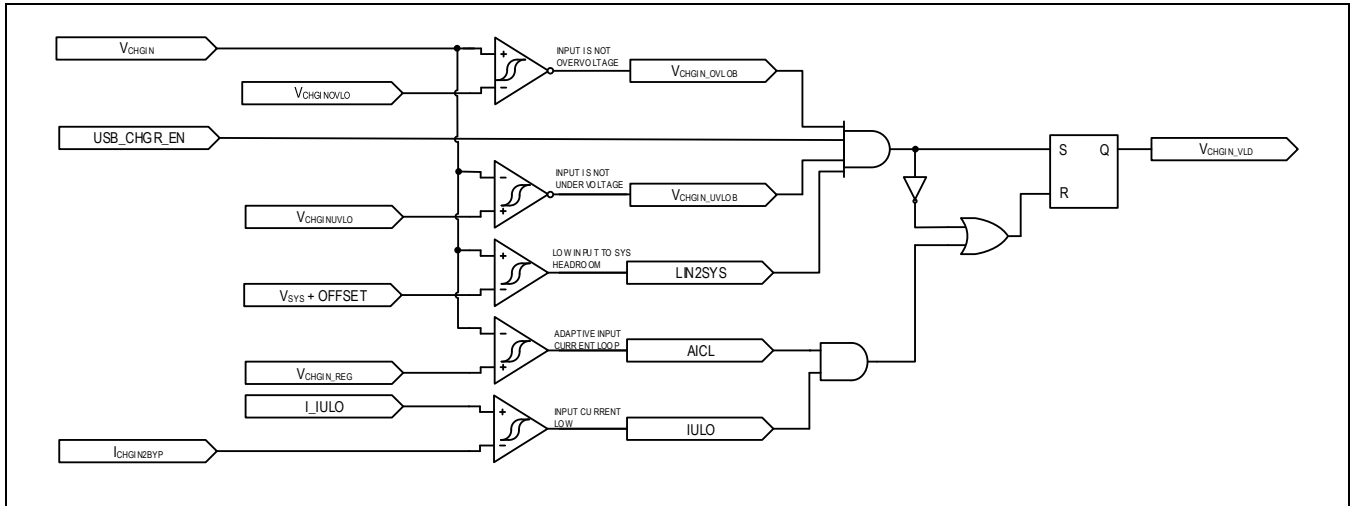

Figure 3. CHGIN Valid Signal Generation Logic

INOKB pin is pulled down when CHGINOK = 1 and the switcher starts.

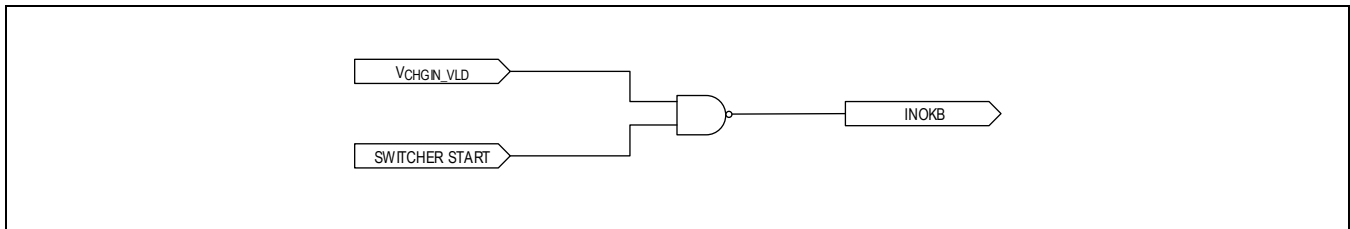

Figure 4. INOKB Signal Generation Logic

Input Current Limit

After the charger type detection is complete, the MAX77757 automatically configures the input current limit to the highest setting that the source can provide. If the input source is not a standard power source described by BC1.2, USB Type-C, or a proprietary charger type that the MAX77757 can detect, the MAX77757 sets the input current limit to 3A.

Input Voltage Regulation Loop

An input voltage regulation loop allows the charger to function well when it is attached to a poor-quality charge source. The loop improves performance with relatively high resistance charge sources that exist when long cables are used or devices are charged with non-compliant USB hub configurations.

The input voltage regulation loop automatically reduces the input current limit in order to keep the input voltage at V_{CHGIN_REG} . If the input current limit is reduced to $I_{CHGIN_REG_OFF}$ (50mA, typ) and the input voltage is below V_{CHGIN_REG} , then the charger input is turned off.

Input Self-Discharge

To ensure that a rapid removal and reinsertion of a charge source always results in a charger input interrupt, the charger input presents loading to the input capacitor to ensure that when the charge source is removed the input voltage decays below the UVLO threshold in a reasonable time (t_{1NSD}). The input self-discharge is implemented with a 44k Ω resistor (R_{1NSD}) from CHGIN input to ground.

Charger States

Li+/Li-Poly Battery

The MAX77757 utilizes several charging states to safely and quickly charge Li+/Li-Poly batteries as shown in [Figure 5](#) and [Figure 6](#). [Figure 5](#) shows an exaggerated view of the Li+/Li-Poly battery progressing through the following charge states when there is no system load and the die and battery are close to room temperature: precharge → trickle → fast-charge → top-off → done.

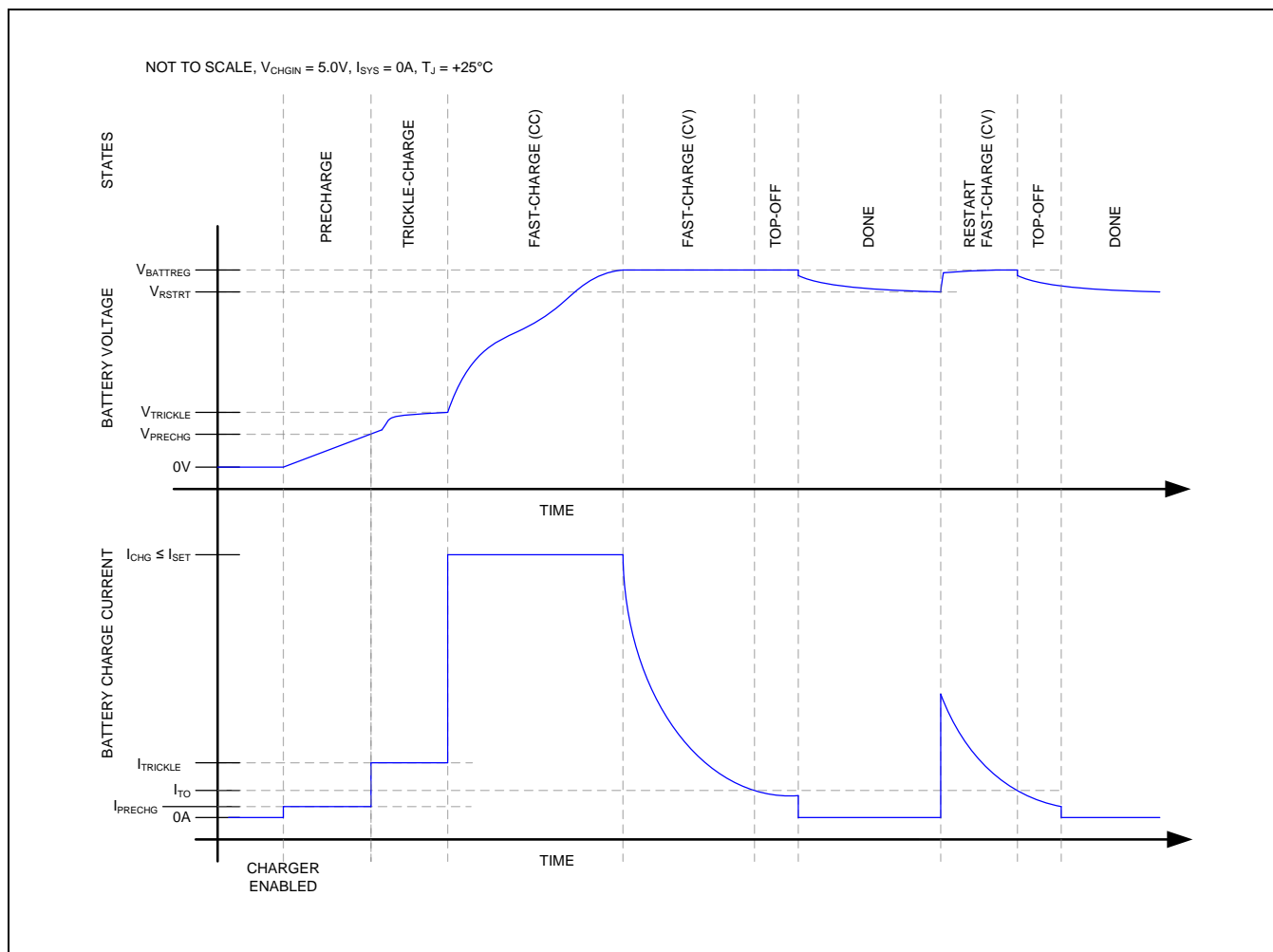

Figure 5. Li+/Li-Poly Charge Profile

LiFePO₄ Battery

As for the LiFePO₄ battery, the MAX77757 skips the trickle charge state and directly enters the fast-charge state after the precharge state. [Figure 7](#) and [Figure 8](#) presents the LiFePO₄ battery charge profile and state machine: precharge → trickle → fast-charge → top-off → done.

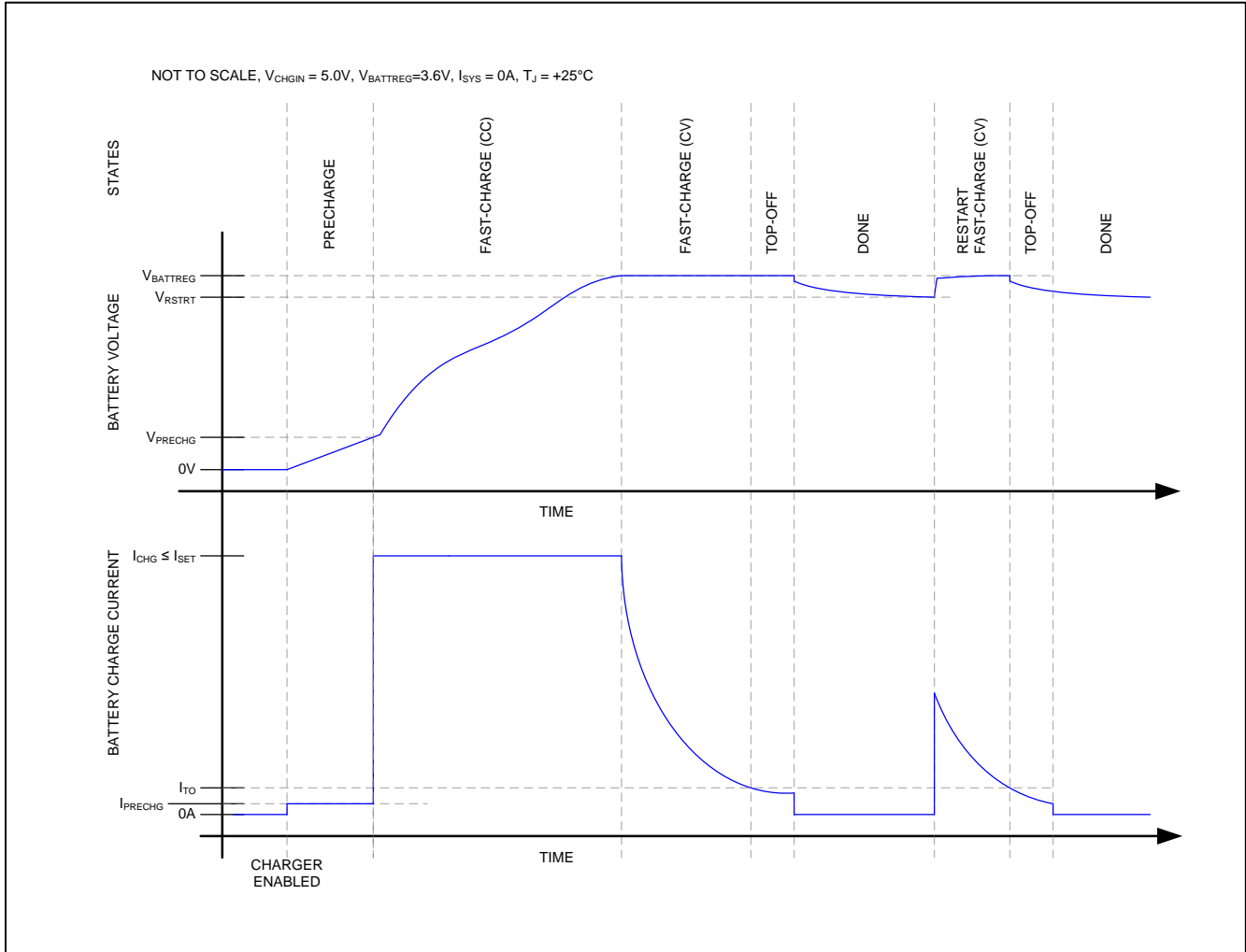

Figure 7. LiFePO₄ Battery Charge Profile

Buck State

In the buck state, battery charging is disabled while the charger input CHGIN is valid. Entering or leaving the buck state is controlled by the voltage of the THM pin. If the voltage of this pin is pulled down by an external device (e.g., MCU) under V_{CHGR_EN} , the chip goes to the buck state from any state if CHGIN is valid as shown in [Figure 6](#). Charging is disabled in the buck state, which means Q_{BAT} is off unless it is in supplement mode. If the voltage of this pin is over V_{CHGR_EN} , the chip leaves the buck state and resumes charging. It should be noted that it is only when CHGIN is valid that charging can be enabled or disabled. Therefore, the external device (e.g., MCU) should check the INOKB signal if CHGIN is valid before trying to enable or disable charging.

Precharge State

As shown in [Figure 6](#), the precharge state occurs when the main battery voltage is less than V_{PRECHG} . In the precharge state, charge current into the battery is I_{PRECHG} .

The following events cause the state machine to exit this state:

- The main battery voltage rises above V_{PRECHG} and the charger enters the next state in the charging cycle, trickle charge.
- If the battery charger remains in this state for longer than t_{PQ} , the charger state machine transitions to the timer fault state.

Note that the precharge state works with battery voltages down to 0V. The low 0V operation typically allows this battery charger to recover batteries that have an “open” internal pack protector. Typically a pack internal protection circuit opens if the battery has seen an overcurrent, undervoltage, or overvoltage. When a battery with an “open” internal pack protector is used with this charger, the precharge mode current flows into the 0V battery—this current raises the pack’s terminal voltage to the point where the internal pack protection switch closes.

Note that a normal battery typically stays in the precharge state for several minutes or less; therefore, a battery that stays in the precharge state for longer than t_{PQ} might be experiencing a problem.

Trickle Charge State

The trickle charge mode described below is for Li-ion and Li-poly batteries only, with charge termination voltage from 4.1V to 4.5V.

The trickle charge state occurs when $V_{BATT} > V_{PRECHG}$ and $V_{BATT} < V_{TRICKLE}$, as shown in [Figure 6](#).

When the MAX77757 is in its trickle charge state, the charge current in the battery is less than or equal to $I_{TRICKLE}$.

Charge current might be less than $I_{TRICKLE}/I_{FC}$ for any of the following reasons:

- The charger input is under input current limit
- The charger input voltage is low
- The charger is in thermal foldback
- The system load is consuming adapter current. Note that the system load always gets priority over the battery charge current.

The following events cause the state machine to exit this state:

- When the main battery voltage rises above $V_{TRICKLE}$, the charger enters the next state in the charging cycle, fast-charge constant current (CC).
- If the battery charger remains in this state for longer than t_{PQ} , the charger state machine transitions to the timer fault state.

Note that a normal battery typically stays in the trickle charge state for several minutes or less; therefore, a battery that stays in trickle charge for longer than t_{PQ} might be experiencing a problem.

Based on the characteristic of the LiFePO4 battery, the trickle charge state of the MAX77757 3.6V option is disabled. After the precharge state, when $V_{PRECHG} < V_{BATT} < V_{BATTREG}$, the MAX77757 enters the fast-charge constant current state to improve the charger efficiency.

Fast-Charge Constant Current State

As shown in [Figure 6](#), the fast-charge constant current (CC) state occurs when the main-battery voltage is greater than the trickle threshold and less than the battery regulation threshold ($V_{TRICKLE} < V_{BATT} < V_{BATTREG}$).

In the fast-charge CC state, the current into the battery is less than or equal to I_{FC} . Charge current can be less than I_{FC} for any of the following reasons:

- The charger input is under input current limit
- The charger input voltage is low
- The charger is in thermal foldback
- The system load is consuming adapter current. Note that the system load always gets priority over the battery charge current.

The following events cause the state machine to exit this state:

- When the main battery voltage rises above $V_{BATTREG}$, the charger enters the next state in the charging cycle, fast-charge constant voltage (CV).
- If the battery charger remains in this state for longer than t_{FC} , the charger state machine transitions to the timer fault state.

The battery charger dissipates the most power in the fast-charge constant current state. This power dissipation causes the internal die temperature to rise. If the die temperature exceeds T_{REG} , I_{FC} is reduced. See the [Thermal Foldback](#) section for more information.

Fast-Charge Constant Voltage State

As shown in [Figure 6](#), the fast-charge constant voltage (CV) state occurs when the battery voltage rises to $V_{BATTREG}$ from the fast-charge CC state.

In the fast-charge CV state, the battery charger maintains $V_{BATTREG}$ across the battery and the charge current is less than or equal to I_{FC} . As shown in [Figure 5](#), charger current decreases exponentially in this state as the battery becomes fully charged.

The smart power selector control circuitry might reduce the charge current lower than the battery can otherwise consume for any of the following reasons:

- The charger input is under input current limit
- The charger input voltage is low
- The charger is in thermal foldback
- The system load is consuming adapter current. Note that the system load always gets priority over the battery charge current.

The following events cause the state machine to exit this state:

- When the charger current is below I_{TO} for t_{TERM} , the charger enters the next state in the charging cycle, top off.
- If the battery charger remains in this state for longer than t_{FC} , the charger state machine transitions to the timer fault state.

Top-Off State

As shown in [Figure 6](#), the top-off state can only be entered from the fast-charge CV state when the charger current decreases below I_{TO} for t_{TERM} . In the top-off state, the battery charger tries to maintain $V_{BATTREG}$ across the battery and typically the charge current is less than or equal to I_{TO} .

The smart power selector control circuitry might reduce the charge current lower than the battery can otherwise consume for any of the following reasons:

- The charger input is under input current limit
- The charger input voltage is low
- The charger is in thermal foldback
- The system load is consuming adapter current. Note that the system load always gets priority over the battery charge current.

The following events cause the state machine to exit this state:

- After being in this state for the top-off time (t_{TO}), the charger enters the next state in the charging cycle, done.
- If $V_{BATT} < V_{BATTREG} - V_{RSTRT}$, the charger goes back to the fast-charge (CC) state

Done State

As shown in [Figure 6](#), the battery charger enters the done state after the charger has been in the top-off state for t_{TO} .

The following event causes the state machine to exit this state:

- If $V_{BATT} < V_{BATTREG} - V_{RSTRT}$, the charger goes back to the fast-charge (CC) state

In the done state, the charge current into the battery (I_{CHG}) is 0A. In the done state, the charger presents a very low quiescent current to the battery. If the system load presented to the battery is low ($<100\mu A$), then a typical system can remain in the done state for many days. If left in the done state long enough, the battery voltage decays below the restart threshold (V_{RSTRT}), and the charger state machine transitions back into the fast-charge CC state. There is no soft-start (di/dt limiting) during the done-to-fast-charge state transition.

Timer Fault State

The battery charger provides a charge timer to ensure safe charging. As shown in [Figure 6](#), the charge timer prevents the battery from charging indefinitely. The time that the charger is allowed to remain in each of the prequalification states is t_{PQ} . The time that the charger is allowed to remain in the fast-charge CC and CV states is t_{FC} . Finally, the time that the charger is in the top-off state is t_{TO} . Upon entering the timer fault state, STAT becomes Hi-Z.

In the timer fault state, the charger is off. The charger input can be removed and re-inserted to exit the timer fault state (See the “any state” bubble in the lower left of [Figure 6](#)).

Thermal Shutdown State

As shown in [Figure 6](#), the thermal shutdown state occurs when the battery charger is in any state and the junction temperature (T_J) exceeds the device’s thermal-shutdown threshold (T_{SHDN}). When T_J is close to REG, the charger folds back the input current limit to 0A so that the charger and inputs are effectively off.

In the thermal shutdown state, the charger is off.

Reverse Boost Mode

The DC-DC converter topology of the MAX77757 allows it to operate as a buck converter or as a reverse boost converter. The modes of the DC-DC converter are controlled by ENBST. When ENBST = high and CHGIN voltage is lower than 0.7V, the DC-DC converter operates in reverse boost mode allowing it to source current to BYP and CHGIN. This mode is commonly referred to as OTG mode or a source role.

The current through the BYP to CHGIN switch is limited to a 1.5A minimum. When the reverse boost mode is enabled, the unipolar CHGIN transfer function measures current going out of CHGIN.

The BYP to CHGIN switch automatically retries after 300ms if CHGIN loading exceeds the 1.5A current limit. If the overload at CHGIN persists, then the CHGIN switch toggles ON and OFF with approximately 60ms ON and 300ms OFF.

Under the reverse boost mode, the CC pins enter the low power source mode until the connection is established. Once Rd is detected, the MAX77757 enables the 180 μA current source of the active CC pin, whereas the other CC pin stays high impedance.

Main Battery Overcurrent Protection During System Power-Up

The main battery overcurrent protection during system power-up feature limits the main battery to system current to I_{SYSPU} if V_{SYS} is less than V_{SYSPU} . This feature limits the surge current that typically flows from the main battery to the device’s low-impedance system bypass capacitors during a system power-up. System power-up occurs anytime that energy from the battery is supplied to SYS when $V_{SYS} < V_{SYSPU}$. This “system power-up” condition typically occurs when a battery is hot-inserted into an otherwise unpowered device.

When “system power-up” occurs due to hot-insertion into an otherwise unpowered device, a small delay is required for this feature’s control circuits to activate. A current spike over I_{SYSPU} might occur during this time.

Main Battery Overcurrent Protection Due To Fault

The MAX77757 protects itself, the battery, and the system from potential damage due to excessive battery discharge current. Excessive battery discharge current can occur for several reasons such as exposure to moisture, a software problem, an IC failure, a component failure, or a mechanical failure that causes a short circuit.

When the main battery (BATT)-to-system (SYS) discharge current (I_{BATT}) exceeds 6A for at least t_{BOVRC} , then the MAX77757 disables the BATT-to-SYS discharge path (Q_{BAT} switch) and turns off the buck. Under OCP fault condition, when SYS is low ($V_{SYS} < V_{SYSUP}$) for t_{ocp_retry} , the MAX77757 restarts on its own and attempts to pull up SYS again. If the fault condition remains, the whole cycle repeats until this fault condition is removed.

Thermal Management

The MAX77757 charger uses several thermal management techniques to prevent excessive battery and die temperatures.

Thermal Foldback

Thermal foldback maximizes the battery charge current while regulating the MAX77757 junction temperature. As shown in [Figure 9](#), when the die temperature exceeds the REGTEMP (T_{REG}), a thermal limiting circuit reduces the battery charger's target current by 5% of the fast-charge current per 1°C (A_{TJREG}), which corresponds to 157.5mA/°C when the fast-charge current is 3.15A. For lower programmed charge currents such as 480mA, this slope is valid for charge current reductions down to 80mA; below 100mA, the slope becomes shallower but the charge current reduces to 0A if the junction temperature is 20°C above the programmed loop set point. The target charge current reduction is achieved with an analog control loop (i.e., not a digital reduction in the input current).

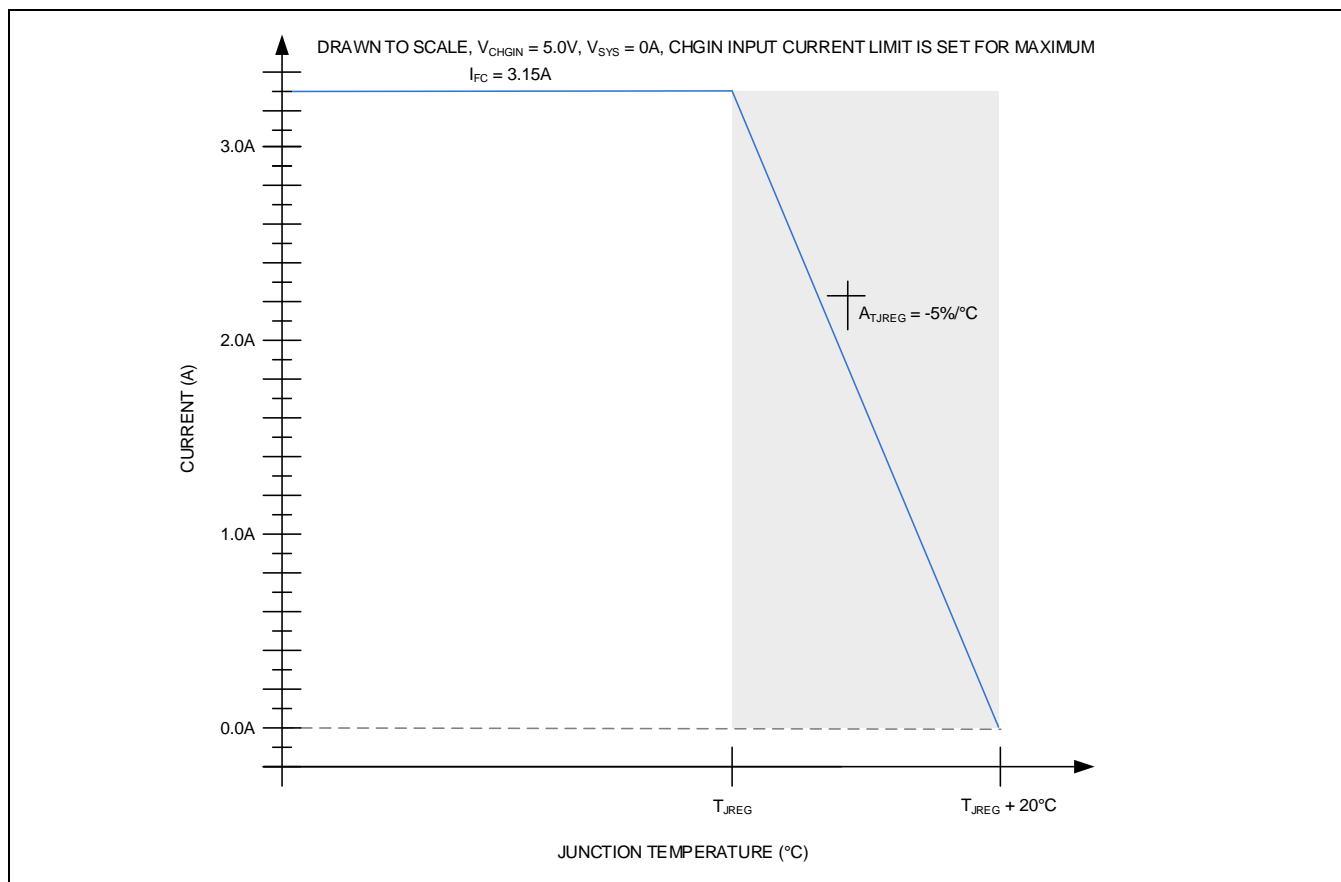

Figure 9. Charge Currents vs. Junction Temperature

Thermistor Input (THM)

The thermistor input can be utilized to achieve functions that include charge suspension, JEITA-compliant charging, and disabling the charger.

The charger can be disabled by pulling the THM pin to ground. [Figure 12](#) shows a recommended system diagram where the MCU has a GPIO output connected to THM to enable or disable charging, and a GPIO input connected to INOKB to check the presence of a valid charger. Note that the GPIO output should be an open-drain type.

JEITA Compliance

The MAX77757J version safely charges batteries in accordance with JEITA specifications. The MAX77757J version monitors the battery temperature with an NTC thermistor connected at the THM pin and automatically adjusts the fast-charge current or charge termination voltage as the battery temperature varies.

The JEITA controlled fast-charge current is reduced to 50% of the detected fast charge current for $T_{COLD} < T < T_{COOL}$.

The charge termination voltage for $T_{WARM} < T < T_{HOT}$ is reduced to programmed termination voltage -150mV, as shown in [Figure 11](#). Charging is suspended when the battery temperature is too cold or too hot ($T < T_{COLD}$ or $T_{HOT} < T$).

The MAX77757H version disables the JEITA under warm and cool conditions and stops charging when the temperature is too hot or cold. See the [Ordering Information](#) for details.

Temperature thresholds (T_{COLD} , T_{COOL} , T_{WARM} , and T_{HOT}) depend on the thermistor selection. See the [Thermistor Input \(THM\)](#) section for more details.

Since the thermistor monitoring circuit employs an external bias resistor from THM to PVL, the thermistor is not limited only to 10k Ω (at +25 $^{\circ}$ C); any resistance thermistor can be used if the value is equivalent to the thermistors +25 $^{\circ}$ C resistance. The thermistor installed on the evaluation kit is 10k Ω with a beta of 3435.

The general relation of thermistor resistance to temperature is defined by the following equation:

$$R_T = R_{25} \times e^{\left[\beta \times \left(\frac{1}{T+273} - \frac{1}{298}\right)\right]}$$

where

R_T = The resistance in Ω of the thermistor at temperature T in Celsius

R_{25} = The resistance in Ω of the thermistor at +25 $^{\circ}$ C

β = The material constant of the thermistor, which typically ranges from 3000k to 5000k

T = The temperature of the thermistor in Celsius

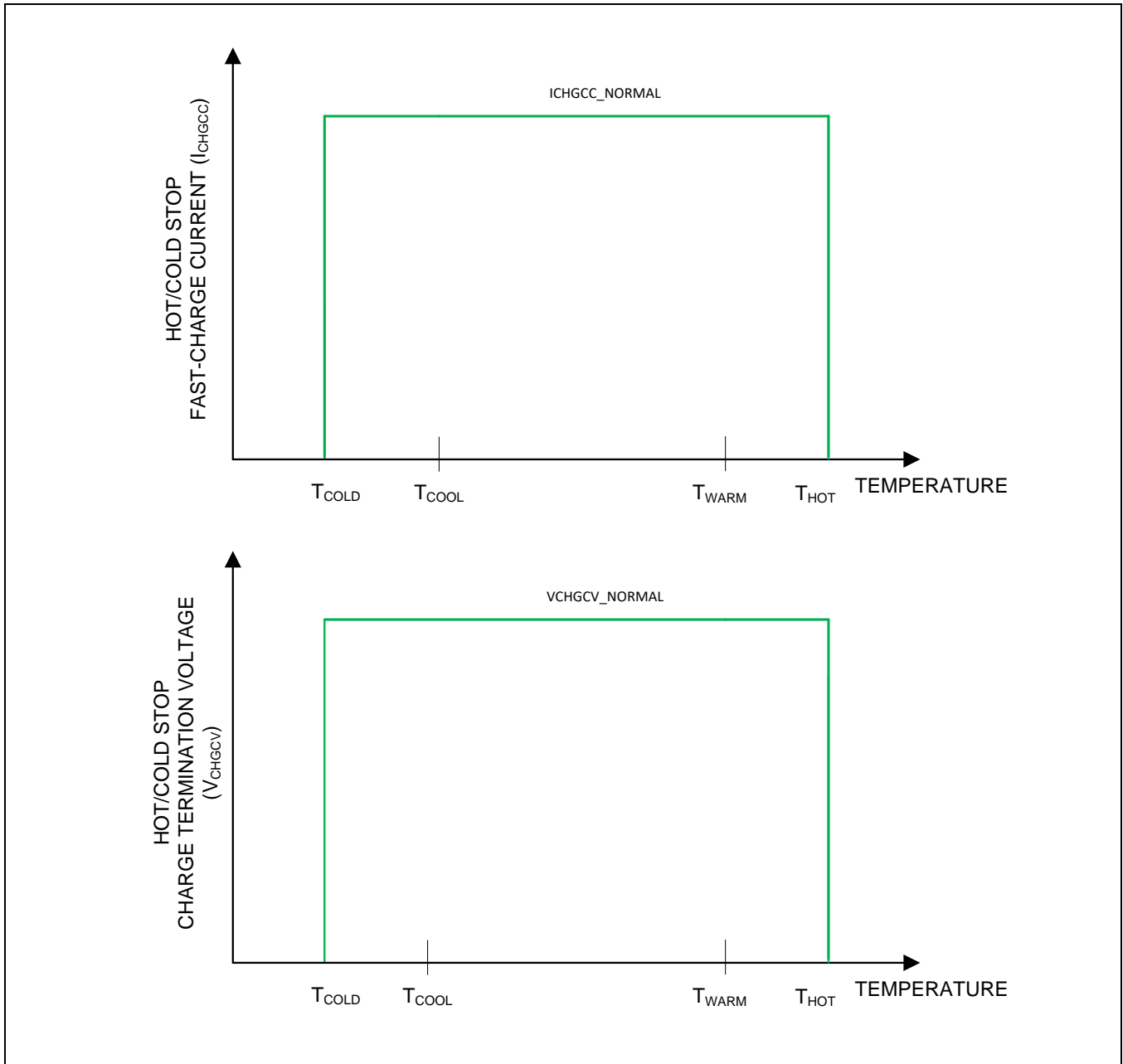

Figure 10. MAX77757H Version Hot/Cold Stop

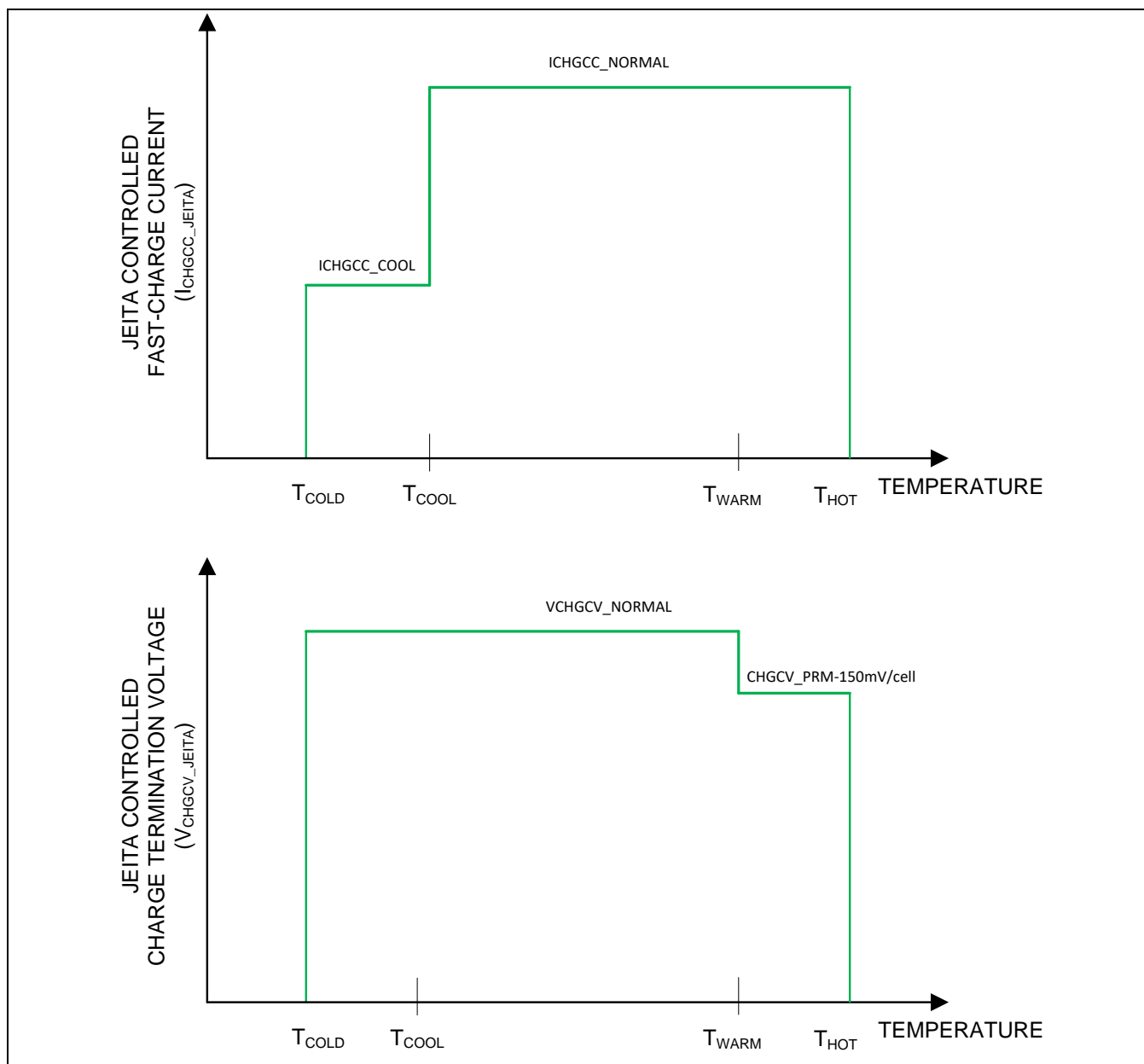

Figure 11. MAX77757J Version JEITA Compliance

V_{DD} Internal Supply

V_{DD} is the 1.8V power for the MAX77757 charger’s analog circuit. V_{DD} chooses the higher value between the BATT and CHGIN as power input source. V_{DD} has a bypass capacitance of 2.2μF.

ENBST For Reverse Boost

ENBST is an input control signal for the reverse boost mode with an external logic signal. If ENBST is driven high, the reverse boost is enabled and the BYP to CHGIN path is closed. It has an internal 235kΩ pulldown resistor. When ENBST sets high, the MAX77757 disconnects R_d from the CC line and provides 180μA current source.

USB BC1.2 Charger Detection**Features**

- D+/D- Charging Signature Detector
- USB BC1.2 Compliant
- SDP, DCP, and CDP Detection
- Detect Proprietary Charger Types
 - Apple® 500mA, 1A, 2A, 12W
 - Samsung® 2A

Description

The USB charger detection is USB BC1.2 compliant with the ability to automatically detect some common proprietary charger types.

The Charger Detection State Machine follows USB BC1.2 requirements and detects SDP, CDP, and DCP types. The Charger Detection State Machine indicates if D+/D- were found as open but ChgTyp indicates SDP as required by BC1.2 specifications.

In addition to the USB BC1.2 State Machine, the IC also detects a limited number of proprietary charger types (Apple, Samsung, and generic 500mA). The UIC automatically sets the CHGIN input current limiting based on the charger type detection results. If the charger type detection results are from an unknown charger type or data contact detection timed out, the input current limits are set to a maximum of 3A.

Table 1. BC1.2 Charger Type

USB BC1.2 DETECTED CHARGER TYPE	
INPUT CURRENT LIMIT	CHARGER DETECTED
500mA	The default setting before charger detection
500mA	SDP
1.5A	CDP
1.5A	DCP

Table 2. Proprietary Charger Type

DETECTED PROPRIETARY CHARGER TYPE	
INPUT CURRENT LIMIT	CHARGER DETECTED
500mA	Apple
1A	Apple
2A	Apple
2.4A	Apple
2A	Samsung
3A	All others

USB Type-C CC Detection**Features**

- USB Type-C sink support
- CC source detection and automatically set the input current limit according to source capability
- Source role is supported by ENBST pin

CC Description

The MAX77757 works as a sink compliant to USB Type-C rev1.2. The USB Type-C functions are controlled by a logic state machine that follows the USB Type-C requirements. The MAX77757 sets the CHGIN input current limit based on the current advertised on the CC wires. Source role is enabled by the ENBST pin. When source role is enabled, Rd is removed and a 180 μ A current source is connected.

Detecting Connected Source

When a source is detected, the USB Type-C state machine auto-detects the active CC line. The state machine also auto-detects the source advertised current (500mA, 1.5A, and 3.0A). Upon detection of a change in advertised current, the MAX77757 automatically sets the input current limit.

Enable Source Role

ENBST = high enables the MAX77757's source role. The MAX77757 disconnects Rd from the CC line and connects a 180 μ A current source to advertise a 5V/1.5A power source. The MAX77757 enables the reverse boost and supplies 5.1V/1.5A through the CHGIN pin.

Applications Information

Fast-Charge Current and Top-Off Current Setting

While a valid input source is present, the battery charger attempts to charge the battery with a fast-charge current determined by the resistance from IFAST to GND. Top-off current matches to the fast-charge current. [Table 3](#) shows resistance values which correspond to target IFAST and ITOPOFF values.

Table 3. Fast-Charge Current and Top-Off Current Setting

RESISTANCE (kΩ)	IFAST (mA)	ITOPOFF (mA)
24.9	3150	150
22.6	3000	150
20.5	2800	125
18.7	2500	125
16.9	2400	125
15.4	2200	100
14	2000	100
12.4	1800	75
11	1500	75
9.53	1400	75
8.2	1200	50
6.65	1000	50
5.23	800	50
3.6	600	50
2.4	500	50

D+/D- Multiplexing

USB D+/D- lines, which are used for the detection of BC1.2 and proprietary Travel Adaptors (TAs), can be used for data communication. If an MCU handles this communication in the target system, the D+/D- lines can be connected to the MAX77757 and the MCU as show in [Figure 12](#). Switchers are required for each D+ and D- line to guarantee Hi-Z for the connections to MCU to avoid wrong detections of TAs (see [Figure 12](#)). It is recommended to connect the INOKB of the MAX77757 to the MCU in this configuration so that the MAX77757 can signal the completion of the detection to the MCU. Once the MCU receives a valid INOKB signal, it can switch the D+/D- lines from the MAX77757 to the MCU for data communication.

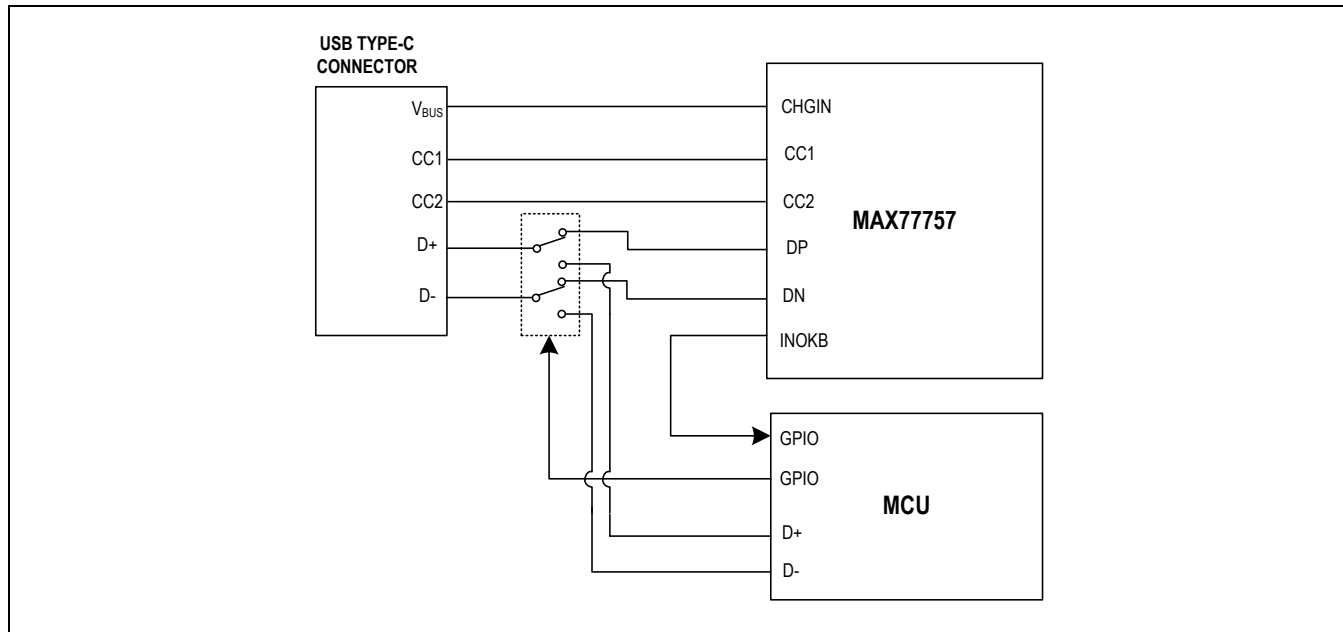

Figure 12. D+/D- Connections in a Reference System

Capacitor Selection

All capacitors should be X5R dielectric or better. Be aware that multi-layer ceramic capacitors have large-voltage coefficients. Before selecting capacitors, check the sufficient voltage rating and derated capacitance at max operating voltage conditions. [Table 5](#) shows proper capacitors after considering the derating and operating voltage.

Table 4. Capacitor Selections

PIN	TYPE
CHGIN Capacitor	2.2µF/16V
BYP Capacitor	10µF + 22µF/16V
SYS Capacitor	2x10µF/10V
BATT Capacitor	10µF/10V
V _{DD} Capacitor	2.2µF/10V
PVL Capacitor	2.2µF/10V
BST Capacitor	0.1µF/6.3V

Non-USB Type Power Source

In an application where the power source is not USB, all the USB-related pins such as CC1, CC2, DP, and DN should be left unconnected. In this case, the input current to MAX77757 is limited to 3A.

Recommended PCB Layout and Routing

Place all bypass capacitors for CHGIN, BYP, SYS, V_{DD} , and BATT as close as possible to the IC. Provide a large copper ground plane to allow the PGND pad to sink heat away from the device. Use wide and short traces for high current connections such as CHGIN, BYP, SYS, and BATT to minimize voltage drops. The MAX77757 has two kinds of ground pins, PGND and GND. Use caution when connecting PGND since it is the switching node ground of the Charger Buck; it should be tied to the ground of the SYS and BYP capacitor and connected to the ground plane directly without sharing the other ground. The GND can be connected to the ground plane.

[Figure 13](#) is a recommended placement and layout guide.

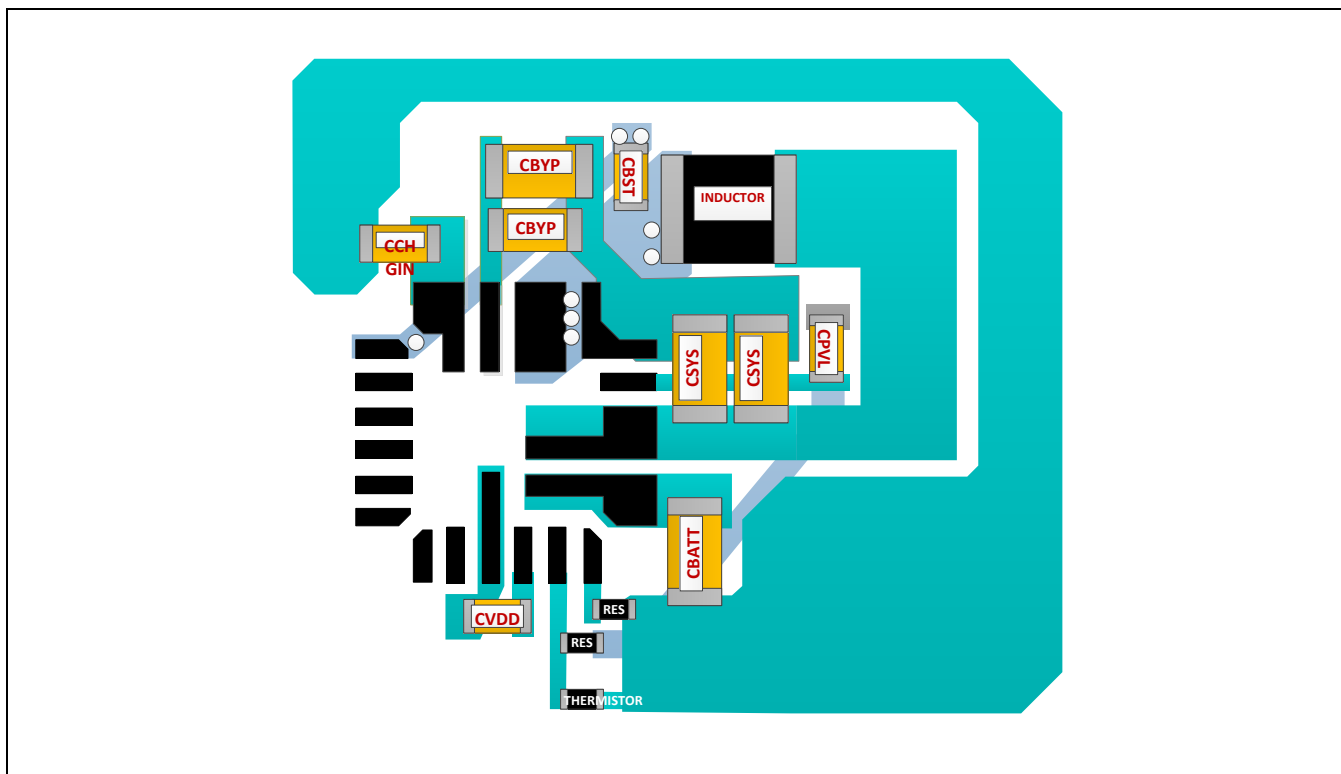

Figure 13. Recommended Placement and Layout

Inductor Selection

The MAX77757's control scheme requires an external inductor from 0.47 μ H to 1 μ H for proper operation.

Table 5. Recommended Inductors

MANUFACTURER	PART NUMBER	INDUCTANCE (μ H)	I _{SAT(TYP)} (A)	I _{RMS(TYP)} (A)	DCR (TYP) (m Ω)	SIZE (L x W x T) (mm)
SEMCO	CIGT252008LMR47MNE	0.47	5.5	4.5	24	2.5 x 2.0 x 0.8
SEMCO	CIGT252010LMR47MNE	0.47	6	4.5	24	2.5 x 2.0 x 1.0
SEMCO	CIGT201610EHR47MNE	0.47	5.9	5	18	2.0 x 1.6 x 1.0
CYNTEC	HTEH25201T-R47MSR-63	0.47	6.6	5.6	16.5	2.5 x 2.0 x 1.0

Charger Status Outputs**Input Status (INOKB)**

INOKB is an open-drain and active-low output that indicates input status. If a valid input source is inserted and the buck converter starts switching, INOKB pulls low. When the reverse boost is enabled, INOKB pulls low to indicate 5V output from CHGIN.

INOKB can be used as a logic output for the system processor by adding a 200k Ω pullup resistor to the system I/O voltage.

INOKB can also be used as a LED indicator driver by adding a current limit resistor and a LED to SYS.

Charging Status Output (STAT)

STAT is an open-drain and active-low output that indicates charge status. STAT status changes as shown in [Table 6](#).

Table 6. STAT Output Per Charging Status

CHARGING STATUS	STAT	LOGIC STATE	CHARGE STATUS LED
No input	High impedance	High	Off
Trickle, precharge, fast charge	Repeat low and high impedance with 1Hz, 50% duty cycle	After an external diode and a capacitor rectifier, high	Blinking with 1Hz, 50% duty cycle
Top-off and done	Low	Low	Solid on
Faults	High impedance	High	Off

STAT can be used as a logic output for the system processor by adding a 200k Ω pullup resistor to the system I/O voltage and a rectifier (a diode and a capacitor).

STAT also can be used as a LED indicator driver by adding a current limit resistor and a LED to SYS.

Typical Application Circuit

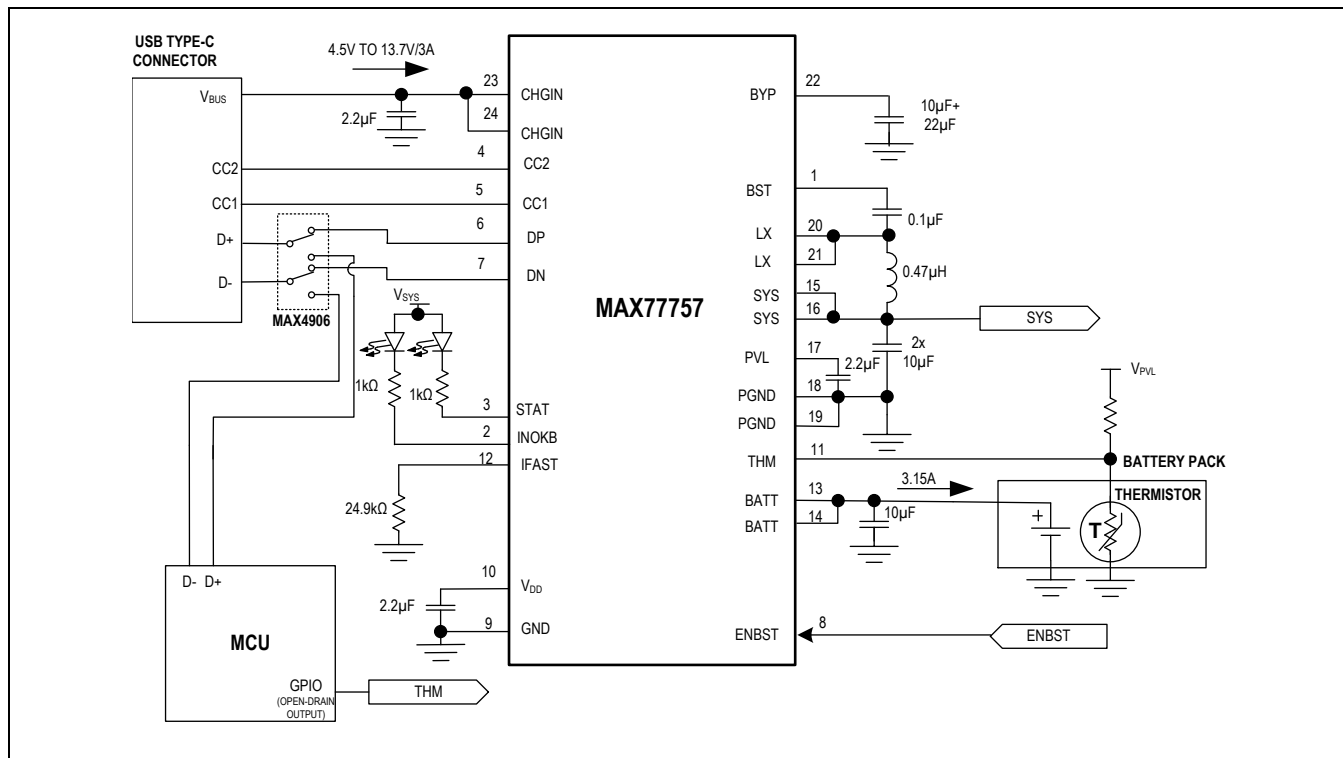

Figure 14. Typical Application Circuit

Ordering Information

PART NUMBER	TEMP RANGE	PIN-PACKAGE	THM	BATTERY CHEMISTRY	BATTERY TERMINATION VOLTAGE (V)
MAX77757JEFG420+	-40°C to +85°C	24 FC2QFN (3mm x 3mm)	JEITA	Li-ion Li-polymer	4.20
MAX77757JEFG420+T	-40°C to +85°C	24 FC2QFN (3mm x 3mm)	JEITA	Li-ion Li-polymer	4.20
MAX77757JEFG430+*	-40°C to +85°C	24 FC2QFN (3mm x 3mm)	JEITA	Li-ion Li-polymer	4.30
MAX77757JEFG430+T*	-40°C to +85°C	24 FC2QFN (3mm x 3mm)	JEITA	Li-ion Li-polymer	4.30
MAX77757JEFG435+	-40°C to +85°C	24 FC2QFN (3mm x 3mm)	JEITA	Li-ion Li-polymer	4.35
MAX77757JEFG435+T	-40°C to +85°C	24 FC2QFN (3mm x 3mm)	JEITA	Li-ion Li-polymer	4.35
MAX77757JEFG440+	-40°C to +85°C	24 FC2QFN (3mm x 3mm)	JEITA	Li-ion Li-polymer	4.40
MAX77757JEFG440+T	-40°C to +85°C	24 FC2QFN (3mm x 3mm)	JEITA	Li-ion Li-polymer	4.40

PART NUMBER	TEMP RANGE	PIN-PACKAGE	THM	BATTERY CHEMISTRY	BATTERY TERMINATION VOLTAGE (V)
MAX77757JEFG450+*	-40°C to +85°C	24 FC2QFN (3mm x 3mm)	JEITA	Li-ion Li-polymer	4.50
MAX77757JEFG450+T*	-40°C to +85°C	24 FC2QFN (3mm x 3mm)	JEITA	Li-ion Li-polymer	4.50
MAX77757HEFG360+	-40°C to +85°C	24 FC2QFN (3mm x 3mm)	HOT/COLD STOP	LiFePO ₄	3.60
MAX77757HEFG360+T	-40°C to +85°C	24 FC2QFN (3mm x 3mm)	HOT/COLD STOP	LiFePO ₄	3.60
MAX77757HEFG370+	-40°C to +85°C	24 FC2QFN (3mm x 3mm)	HOT/COLD STOP	LiFePO ₄	3.70
MAX77757HEFG370+T	-40°C to +85°C	24 FC2QFN (3mm x 3mm)	HOT/COLD STOP	LiFePO ₄	3.70
MAX77757HEFG420+*	-40°C to +85°C	24 FC2QFN (3mm x 3mm)	HOT/COLD STOP	Li-ion Li-polymer	4.20
MAX77757HEFG420+T*	-40°C to +85°C	24 FC2QFN (3mm x 3mm)	HOT/COLD STOP	Li-ion Li-polymer	4.20
MAX77757HEFG430+*	-40°C to +85°C	24 FC2QFN (3mm x 3mm)	HOT/COLD STOP	Li-ion Li-polymer	4.30
MAX77757HEFG430+T*	-40°C to +85°C	24 FC2QFN (3mm x 3mm)	HOT/COLD STOP	Li-ion Li-polymer	4.30
MAX77757HEFG435+*	-40°C to +85°C	24 FC2QFN (3mm x 3mm)	HOT/COLD STOP	Li-ion Li-polymer	4.35
MAX77757HEFG435+T*	-40°C to +85°C	24 FC2QFN (3mm x 3mm)	HOT/COLD STOP	Li-ion Li-polymer	4.35
MAX77757HEFG440+*	-40°C to +85°C	24 FC2QFN (3mm x 3mm)	HOT/COLD STOP	Li-ion Li-polymer	4.40
MAX77757HEFG440+T*	-40°C to +85°C	24 FC2QFN (3mm x 3mm)	HOT/COLD STOP	Li-ion Li-polymer	4.40
MAX77757HEFG450+*	-40°C to +85°C	24 FC2QFN (3mm x 3mm)	HOT/COLD STOP	Li-ion Li-polymer	4.50
MAX77757HEFG450+T*	-40°C to +85°C	24 FC2QFN (3mm x 3mm)	HOT/COLD STOP	Li-ion Li-polymer	4.50

+Denotes a lead(Pb)-free/RoHS-compliant package.

T = Tape and reel.

*Future product—contact factory for availability.

Revision History

REVISION NUMBER	REVISION DATE	DESCRIPTION	PAGES CHANGED
0	3/21	Initial release	—
1	3/21	Updated <i>Ordering Information</i> table	33, 34
2	6/21	Updated <i>Electrical Characteristics</i> table, changed Figure 10 to 11 and Figure 11 to 12, updated <i>Ordering Information</i> table	4, 24–26, 34

USB Type-C is a registered trademark of USB Implementers Forum.
Smart Power Selector is a trademark of Maxim Integrated Products, Inc.
Apple is a registered trademark of Apple Inc.
Samsung is a registered trademark of Samsung Electronics Co., Ltd.

For pricing, delivery, and ordering information, please visit Maxim Integrated's online storefront at <https://www.maximintegrated.com/en/storefront/storefront.html>.

Maxim Integrated cannot assume responsibility for use of any circuitry other than circuitry entirely embodied in a Maxim Integrated product. No circuit patent licenses are implied. Maxim Integrated reserves the right to change the circuitry and specifications without notice at any time. The parametric values (min and max limits) shown in the *Electrical Characteristics* table are guaranteed. Other parametric values quoted in this data sheet are provided for guidance.

Looking for pricing, stock, or lifecycle information?

Click below to explore more details on WIN SOURCE:

 [View MAX77757JEFG420+T on WIN SOURCE](#)

 [Analog Devices Inc. Information](#)

Optimize Your Supply Chain with WIN SOURCE Solutions

-  Global Sourcing Solution
-  Obsolete Management
-  Cost Control Management
-  Shortage Management
-  Alternative Solution
-  Excess Inventory Management