



### Evaluation Board for the 8-/10-Lead Family of 14-/16-/18-Bit PuSAR ADCs

#### FEATURES

- Full featured evaluation board for 8-/10-lead PuSAR ADCs
- Versatile analog signal conditioning circuitry
- On-board reference, reference buffers, and ADC drivers
- PC software for control and data analysis of time and frequency domain
- System demonstration platform compatible (EVAL-SDP-CB1Z)

#### EQUIPMENT NEEDED

- Evaluation board (see Table 5)
- Wall adapter power supply
- Additional equipment needed
  - SDP board (EVAL-SDP-CB1Z) (optional)
  - Precision source
  - Cable (SMA input to evaluation board)

#### GENERAL DESCRIPTION

The 10-lead PuSAR® evaluation board covers the following 10-lead PuSAR analog-to-digital converters (ADCs): AD7685 (16-bit), AD7686 (16-bit), AD7687 (16-bit), AD7688 (16-bit), AD7690 (18-bit), AD7691 (18-bit), AD7693 (16-bit), AD7942 (14-bit), AD7946 (14-bit), AD7980 (16-bit), AD7982 (18-bit), AD7983 (16-bit), AD7984 (18-bit), AD7988-5 (16-bit), AD7989-5 (18-bit), AD7915 (16-bit) and AD7916 (16-bit).

The 8-lead PuSAR evaluation board covers the following 8-lead PuSAR ADCs: AD7683 (16-bit), AD7684 (16-bit), and AD7694 (16-bit).

These low power ADCs offer very high performance of up to 18 bits with throughputs ranging from 100 kSPS to 1.33 MSPS. The evaluation board is designed to demonstrate the performance of the ADCs and to provide an easy to understand interface for a variety of system applications. A full description of these products is available in their respective data sheets, which should be consulted when using this evaluation board.

The evaluation board is ideal for use with Analog Devices, Inc., system demonstration platform (SDP). This evaluation board interfaces to the SDP board via a 120-pin connector. SMA connectors, J6 and J10, are provided for the low noise analog signal source.

On-board components include a high precision buffered band gap 5.0 V reference (ADR435), a signal conditioning circuit with two op amps (ADA4841-1), and a power supply to derive the necessary voltage levels to supply all voltage needs. The 8-lead board also includes a level shifter (ADG3304) to interface the ADC with the EVAL-SDP-CB1Z.

#### SIMPLIFIED EVALUATION BOARD BLOCK DIAGRAM

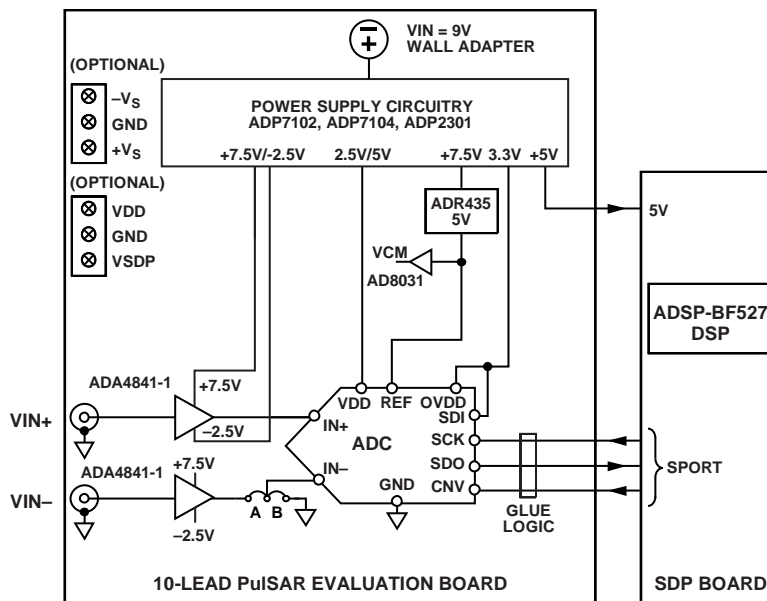

Figure 1.

**TABLE OF CONTENTS**

Features .....	1	Running the Software with the Hardware Connected .....	7
Equipment Needed.....	1	Running the Software Without Hardware .....	8
General Description .....	1	Software Operation .....	9
Simplified Evaluation Board Block Diagram.....	1	Description of User Panel .....	10
Revision History .....	2	Waveform Capture .....	11
Evaluation Board Kit Contents.....	3	AC Testing—Histogram .....	12
Hardware Requirements.....	3	DC Testing—Histogram.....	13
Evaluation Board Hardware.....	4	AC Testing—FFT Capture .....	13
Setting Up the Evaluation Board.....	4	Summary Tab.....	14
Power Supplies .....	4	Save File .....	15
Reference .....	4	Load File .....	15
Serial Interface .....	4	Evaluation Board Schematics.....	16
Solder Links.....	4	Troubleshooting.....	29
Analog Inputs.....	4	Software .....	29
Evaluation Board Software .....	5	Hardware .....	29
Installing the Software .....	5	Products on this Evaluation Board .....	30
Installation Steps.....	5	Related Links.....	30
Board Operation/Connection Sequence.....	7		

**REVISION HISTORY**

**3/15—Rev. B to Rev. C**

Changes to General Description Section .....	1
Changes to Table 3.....	4
Changes to Table 5.....	30

**2/14—Rev. A to Rev. B**

Changes to Equipment Needed Section and General Description Section.....	1
Changes to Evaluation Kits Contents Section .....	3
Change to Table 3 .....	4
Changes to Table 5.....	30

**10/12—Rev. 0 to Rev. A**

Added 8-Lead PulSAR Evaluation Board .....	Universal
Changes to Description of User Panel Section .....	10
Changes to Figure 27 Caption .....	16
Added Figure 28; Renumbered Sequentially .....	17
Changes to Figure 36 Caption and Figure 37 Caption .....	23
Changes to Figure 38 Caption and Figure 39 Caption .....	24
Changes to Figure 40 Caption .....	25
Added Figure 41 and Figure 42 .....	26
Added Figure 43 and Figure 44 .....	27
Added Figure 45 .....	28
Changes to Software Section.....	29
Changes to Table 5 and Related Links Section .....	30

**5/12—Revision 0: Initial Version**

**EVALUATION BOARD KIT CONTENTS**

Evaluation board for ADC of your choice  
(U1 device is specific to the evaluation board ordered)  
Business card with Analog Devices website address for  
software and documentation  
9 V wall wart

**HARDWARE REQUIREMENTS**

9 V wall wart (supplied)  
Standard USB A to Mini-B USB cable  
Signal source, ac source with low distortion, and dc source  
with low noise  
Band-pass filter suitable for 16- and 18-bit testing (value  
based on signal frequency)  
SDP board for data transfer to PC  
Signal source and cables

## EVALUATION BOARD HARDWARE

### SETTING UP THE EVALUATION BOARD

Figure 27 shows the evaluation board schematic. The board consists of the ADC, U1, with a reference, U6 ([ADR435](#)), and ADC drivers, U12 and U14 ([ADA4841-1](#)). The 8-lead board also has a level shifter, U16 ([ADG3304](#)).

The evaluation board is a flexible design that enables the user to adjust compensation components in addition to operating from an adjustable bench top power supply.

### POWER SUPPLIES

The evaluation board requires power from a wall adapter. The on-board power supply design is designed to operate from 9 V.

**Table 1. Power Supplies Provided on the Board**

Power Supply (V)	Function	Components Used
+5	SDP power	<a href="#">ADP2301</a>
+7.5	Positive rail	<a href="#">ADP7102</a>
-2.5	Negative rail	<a href="#">ADP2301</a>
+2.5/+5	ADC	<a href="#">ADP7104</a>
+3.3	V <sub>DRIVE</sub> (digital power)	<a href="#">ADP7104</a>

Each supply is decoupled where it enters the board and again at each device. A single ground plane is used on this board to minimize the effect of high frequency noise interference.

In addition to this, there is also the ability to power the board from a bench top power supply. The screw terminals, J2 and J3, are provided for this function. When bench power is used, the wall wart and on-board power supply are no longer required. Solder links also must be changed: SL1 = B, SL2 = B, SL7 = B, SL4 = B, and SL3 = B.

### REFERENCE

An external 5 V reference (U6, [ADR435](#)) is used to supply the ADCs directly.

### SERIAL INTERFACE

The evaluation board uses the SPORT interface from the [ADSP-BF527](#) DSP.

A number of AND gates are used to clock and gate the SPORT transfer to the ADC device. See U9, U10, and U11. The 8-lead board also has a level shifter, U16 ([ADG3304](#)), which interfaces the ADC logic levels (5 V) to the [EVAL-SDP-CB1Z](#) (3.3 V).

### SOLDER LINKS

There is one three solder link option on the board. It is configured depending on which generic of the ADC is on the specific evaluation board as described in Table 3.

**Table 2. Table of Jumper Detail with Factory Default Setting**

Link	Setting	Function	Comment
SL2	A	-V <sub>s</sub>	Change to B if using bench supplies
SL1	A	+V <sub>s</sub>	Change to B if using bench supplies
SL3	A	V <sub>_SDP</sub>	Change to B if using bench supplies
SL7	A	VDD for ADC	Change to B if using bench supplies
SL4	A	VREF	Change to B if using bench supplies

**Table 3. Table of Jumpers Specific to Different ADCs**

Link	Setting	Configuration	Generic
SL10	A	Differential input	<a href="#">AD7684</a> , <a href="#">AD7687</a> , <a href="#">AD7688</a> , <a href="#">AD7690</a> , <a href="#">AD7691</a> , <a href="#">AD7693</a> , <a href="#">AD7982</a> , <a href="#">AD7984</a> , <a href="#">AD7989-5</a> , <a href="#">AD7915</a> , <a href="#">AD7916</a>
SL10	B	Single-ended	<a href="#">AD7683</a> , <a href="#">AD7685</a> , <a href="#">AD7686</a> , <a href="#">AD7694</a> , <a href="#">AD7942</a> , <a href="#">AD7946</a> , <a href="#">AD7980</a> , <a href="#">AD7983</a> , <a href="#">AD7988-5</a>

### ANALOG INPUTS

The analog inputs to the evaluation board are SMA connectors, J6 and J10. These inputs are buffered with dedicated amplifier circuitry (U12 and U14), as shown in Figure 27. The circuit allows different configurations, input range scaling, filtering, addition of a dc component, and use of different op amp and supplies. The analog input amplifiers are set as unity-gain buffers at the factory. The amplifier positive rail is driven from 7.5 V (from U13, [ADP7102](#)). The negative amplifier rail is driven from -V<sub>s</sub> (generated by U3, [ADP2301](#)).

The default configuration sets both U12 and U14 at midscale, generated from a buffered reference voltage divider (VCM).

The evaluation board is factory configured for providing either a single-ended path or a fully differential path as shown in Table 3.

For dynamic performance, a fast Fourier transform (FFT) test can be done by applying a very low distortion ac source.

For low frequency testing, the audio precision source can be used directly because the outputs on these are isolated. Set the outputs for balanced and floating ground. Different sources can be used; however, most are single-ended sources that use a fixed output resistance.

Because the evaluation board uses the amplifiers in unity-gain, the noninverting input has a common-mode input with a series 590 Ω resistor, and it needs to be taken into account when directly connecting a source (voltage divider).

## EVALUATION BOARD SOFTWARE INSTALLING THE SOFTWARE

The evaluation board software can be downloaded from the relevant product page on the Analog Devices website.

Install the software prior to connecting the SDP board to the USB port of the PC. This ensures that the SDP board is recognized when it connects to the PC.

1. Start the Windows® operating system and download the software from the relevant product page on the Analog Devices website.
2. Unzip the downloaded file. Run the **setup.exe** file.
3. After installation is completed, power up the evaluation board as described in the Power Supplies section.
4. Plug the evaluation board into the SDP board and the SDP board into the PC using a USB cable.
5. When the software detects the evaluation board, proceed through any dialog boxes that appear to finalize the installation.

The default location for the software is the following:

**C:\Program Files\Analog Devices\8 & 10 Lead PulSAR ADCs.**

This location contains the executable software and example files.

### INSTALLATION STEPS

Proceed through the installation, allowing the software and drivers to be placed in the appropriate locations. Connect the SDP board to the PC only after the software and drivers have been installed.

There are two parts to the software installation. First, install the software related to the evaluation board, as shown in Figure 2 to Figure 7.

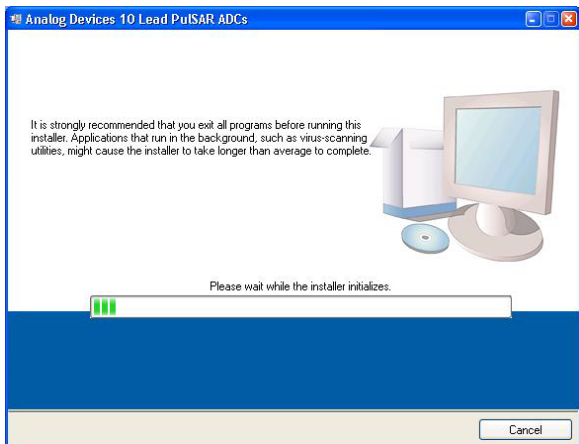

Figure 2. Evaluation Board Software Installation Launches

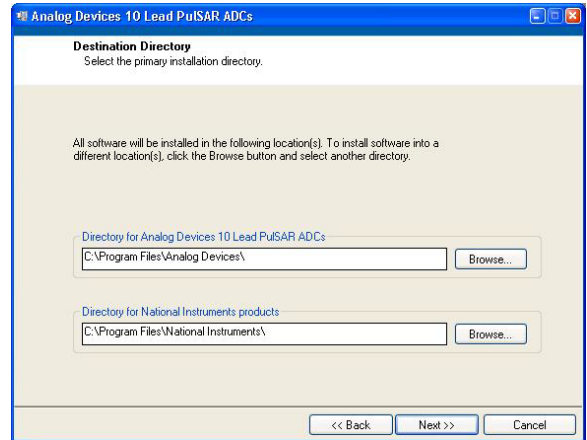

Figure 3. Choose Folder Location, Default Folder Shown

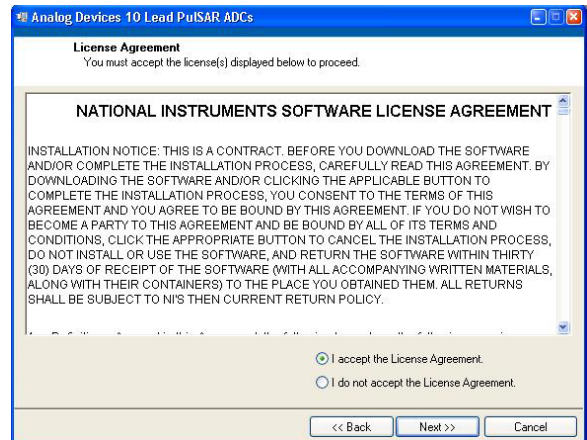

Figure 4. Accept National Instruments Software License Agreement

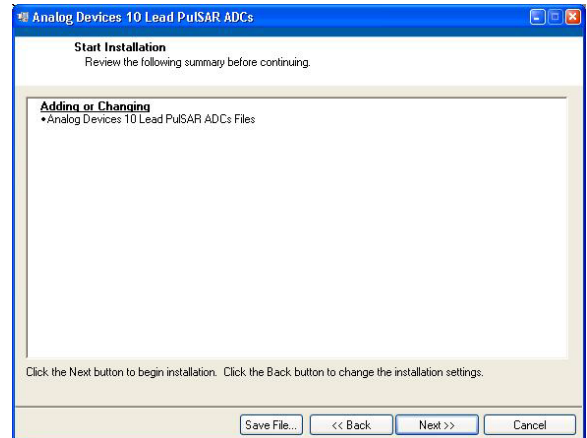

Figure 5. Click **Next >>** to Install Software

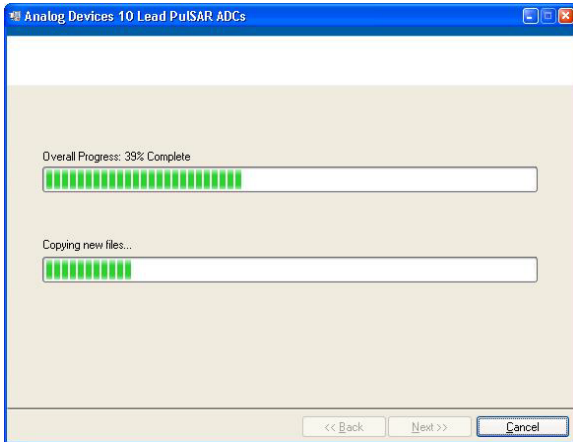

Figure 6. Bar Showing Installation Progress

10322-006



Figure 9. Click **Next >** to Install the ADI SDP Drivers

10322-009

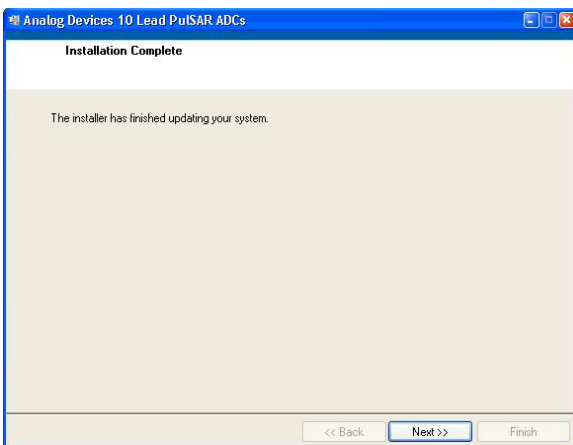

Figure 7. **Installation Complete**, Click **Next >>** to Complete and Finish

10322-007

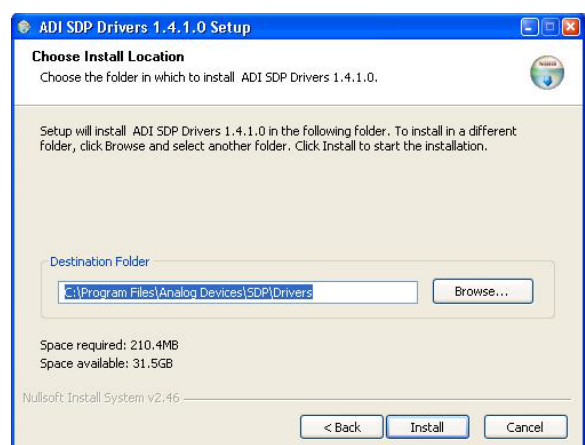

Figure 10. **Choose Install Location**, Default Folder Shown

10322-010

The second part of the software installation is the drivers related to the SDP board. These drivers must be installed for the evaluation board to function correctly. See Figure 8 to Figure 12.

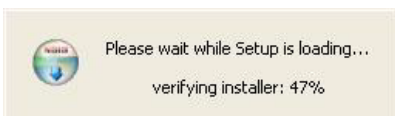

Figure 8. Installation for SDP Starting

10322-008

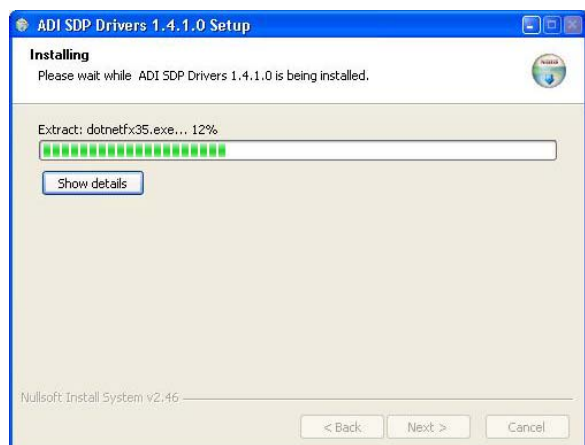

Figure 11. Installation in Progress

10322-011



Figure 12. Click **Finish** to Complete Installation

When you first plug in the SDP board via the USB cable provided, allow the new **Found Hardware Wizard** to run. You can check that the drivers and the board are connected correctly by looking at the **Device Manager** of the PC. The **Analog Devices System Development Platform (32MB)** should appear under **ADI Development Tools**.



Figure 13. Device Manager

**BOARD OPERATION/CONNECTION SEQUENCE**

The following is the board operation/connection sequence:

1. Connect the SDP controller board to the evaluation board with the J5 connector (screw into place as required). The software is configured to find the evaluation board on either connector of the SDP board.
2. Power the board with the appropriate supply as described in the Power Supplies section.
3. Connect to the PC with the USB cable.
4. Launch the software. Click **Start > All Programs > Analog Devices > 8 & 10 Lead PulSAR ADCs**.
5. Apply signal source and capture data.

**RUNNING THE SOFTWARE WITH THE HARDWARE CONNECTED**

To run the program, take the following steps:

1. Click **Start > All Programs > Analog Devices > 8 & 10 Lead PulSAR ADCs**. To uninstall the program, click **Start > Control Panel > Add or Remove Programs > Analog Devices 8 & 10 Lead PulSAR ADCs**.
2. If the SDP board is not connected to the USB port when the software is launched, a connectivity error displays (see Figure 14). Connect the evaluation board to the USB port of the PC, wait a few seconds, click **Rescan**, and follow the instructions.

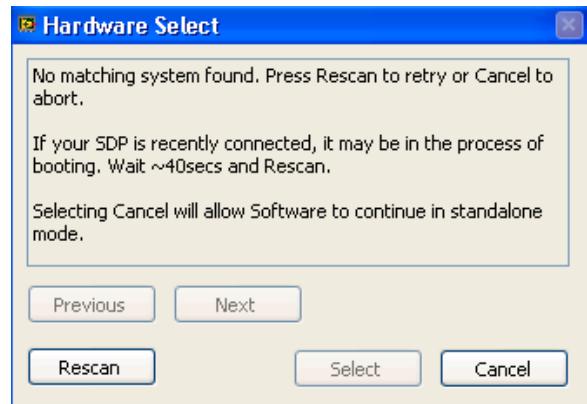

Figure 14. SDP Board Not Connected to the USB Port Pop-Up Window Error

3. When evaluation board is detected, Figure 15 displays. Click **OK** to continue.

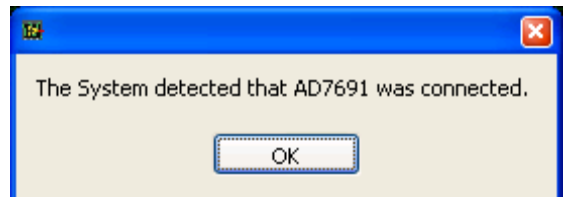

Figure 15. Software Detects Evaluation Board

4. The software then connects to the board and displays what is shown in Figure 16.

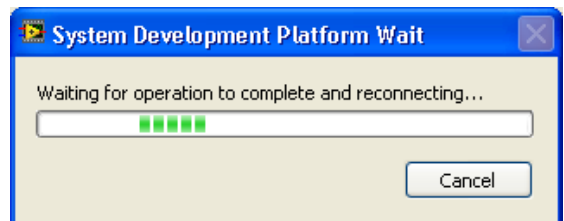

Figure 16. Software Connects to SDP Board

5. When the board is correctly detected, the software panel opens.

**RUNNING THE SOFTWARE WITHOUT HARDWARE**

The software can run in standalone mode when no evaluation board hardware is connected to the USB port.

1. Click **Start > All Programs > Analog Devices > 8 & 10 Lead PulSAR ADCs**.
2. The software automatically seeks to find the hardware connected; therefore, when no hardware is connected, it displays a connectivity error (see Figure 17). To continue without hardware in standalone mode, click **Cancel**.

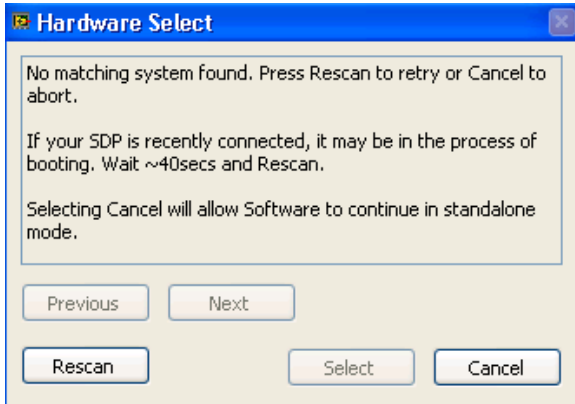

Figure 17. No Hardware Connected Pop-Up Window Error

3. The software alerts you that no hardware is connected, and that the software will continue in standalone mode.

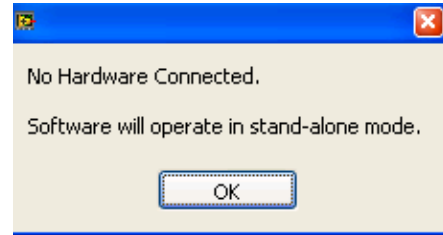

Figure 18. Software Indicates Operating in Standalone Mode

4. Within standalone/offline mode, you can load example files or previously saved files and analyze these files.
5. If you decide to connect hardware at this point, close the software and relaunch it to allow the software to search for the board again.

### SOFTWARE OPERATION

When the software launches, the panel opens and the software looks for the hardware connected to the PC. The software detects the generic attached to the PC (see Figure 19). The product panel then launches.

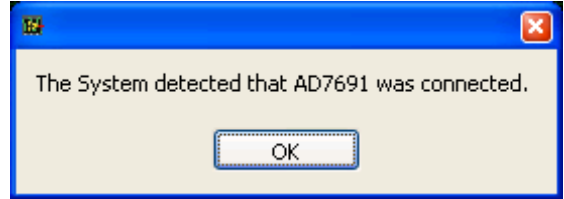

Figure 19. Software Detects AD7691

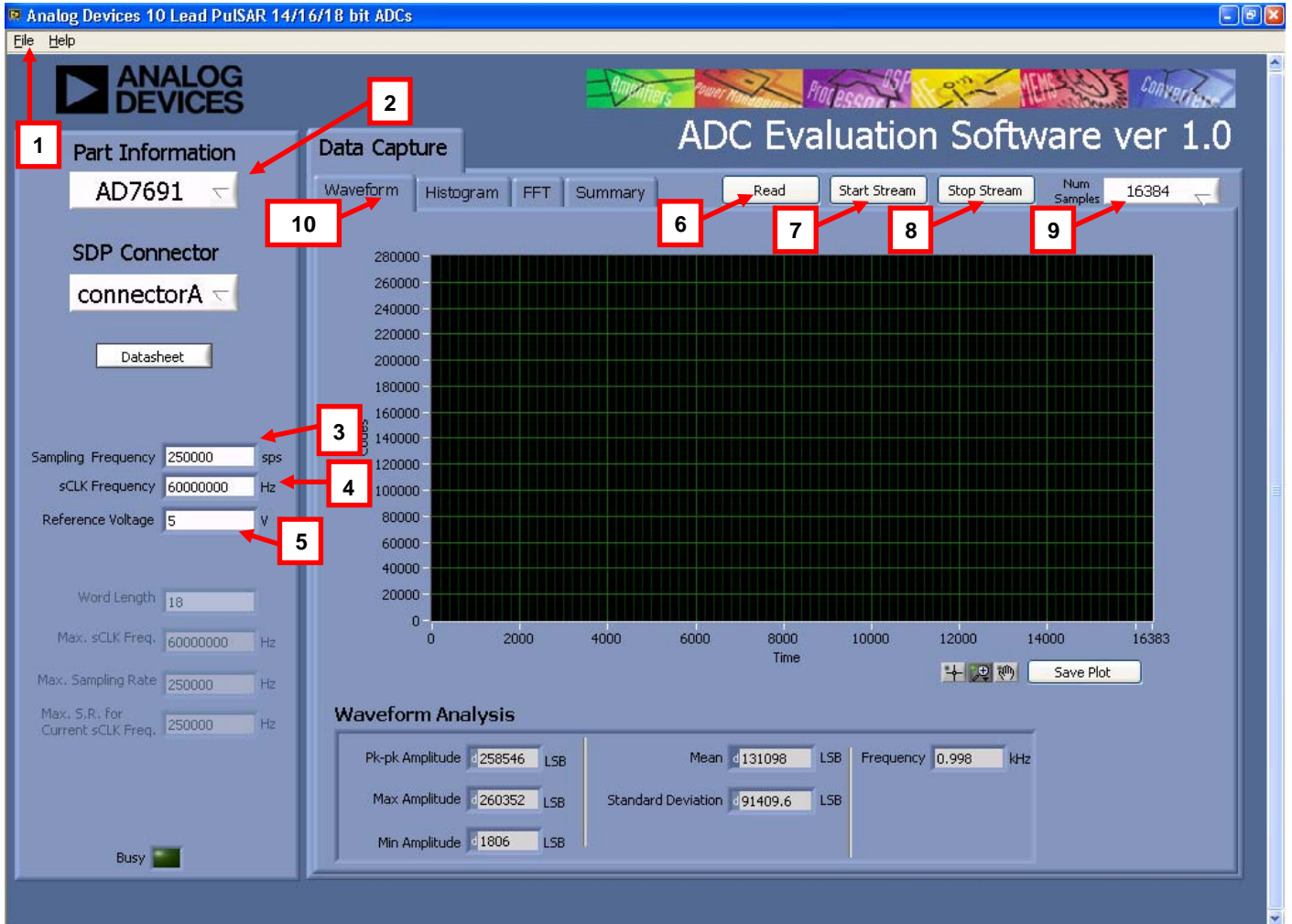

Figure 20. Setup Screen

**DESCRIPTION OF USER PANEL**

The following is the description of the user panel:

1. File menu with choice of
  - a. **Load Data:** load previously captured data
  - b. **Save Data as .tsv:** save captured data in tsv (tab separated values) format for future analysis
  - c. **Save Picture:** use to save the current screen capture
  - d. **Print**
  - e. **Exit**
2. When hardware is connected to the USB port, the software automatically detects which generic is connected and displays it here. Without hardware, the software can be operated in standalone mode for data analysis, and the device information notes the device number pulled from the saved data file.
3. **Sampling Frequency:** The default sampling frequency matches the maximum sample rate of the ADC connected to the board. The user can adjust the sampling frequency; however, there are limitations around the sample frequency related to the SCLK frequency applied. The sample frequency must be an integer divider of the SCLK frequency. In addition, where unusable sample frequencies are input, the software automatically adjusts the sample frequency accordingly. Units can be entered, such as 10k for 10,000 Hz. Because the maximum sample frequency possible is device dependent, with some of the ADCs capable of operating up to 250 kSPS, while others can go to 1.3 MSPS, the software matches the particular ADC ability. If the user enters a value larger than the ability of the existing device, the software indicates this and reverts to the maximum sample frequency.
4. **sCLK Frequency:** The default SCLK frequency is set to 60 MHz, which is the maximum allowable from the SDP. The SCLK is applied to the ADC SCK pin. The SDP board limits the SCLK frequency; nominal values for correct operation are 60 MHz, 30 MHz, and 20 MHz. Where the user adjusts the SCLK/sample rate to values that are not supported by the SDP clock or the ADC sample rate, the software overrides by adjusting values accordingly and identify this to the user (see Figure 21). The SCLK frequency is rounded down.





Figure 21. Software Overwritten User Settings to a Sample Rate/SCLK Rate Suitable for SDP Data Transfer

5. **External Reference Voltage.** By default, this reference is 5 V (ADR435 on-board reference). The minimum/maximum voltage calculations are based on this reference voltage. If the user changes the reference voltage, this input must be changed accordingly.
6. Click **Read** to perform a single capture.
7. Click **Start Stream** to perform a continuous capture from the ADC.
8. Click **Stop Stream** to stop streaming data.
9. Select the number of samples (**Num Samples**) to analyze.
10. There are four tabs available that display the data in different formats:
  - a. **Waveform**
  - b. **Histogram**
  - c. **FFT**
  - d. **Summary**

To exit the software, go to **File > Exit** or use the **EXIT** button in the bottom left corner.

Within any of the chart panels, the tools shown in Table 4 allow user control of the different chart displays.

**Table 4.**

Symbol	Description
	This tool is used to control the cursor, if present.
	This tool is used to zoom in and out.
	This tool is used for panning.

To save the plot, click **Save Plot**.

**WAVEFORM CAPTURE**

Figure 22 illustrates the waveform capture. The input signal is a 1 kHz sine wave. The waveform analysis reports the amplitudes recorded from the captured signal in addition to the frequency of the signal tone.

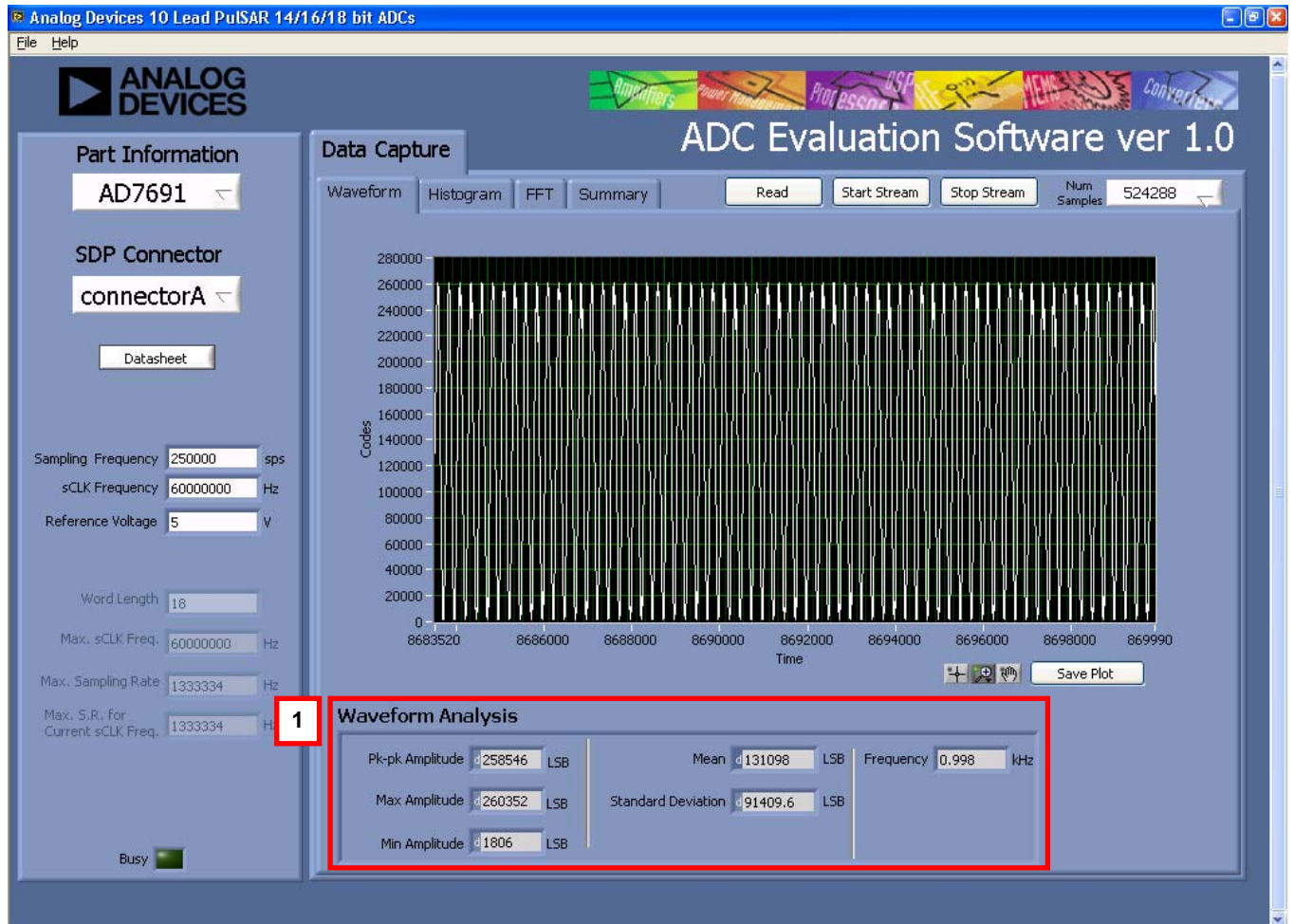

Figure 22. Waveform Tab

**AC TESTING—HISTOGRAM**

The ac testing histogram tests the ADC for the code distribution for the ac input, computes the mean and standard deviation, or transition noise, of the converter, and displays the results. Raw data is captured and passed to the PC for statistical computations. To perform a histogram test, select **Histogram** and click **Start Stream**.

Note that an ac histogram needs a quality signal source applied to the input J6/J10 connectors. Figure 23 shows the histogram for a 1 kHz sine wave applied to the ADC input.

Figure 23 shows the histogram results for the signal applied. It also illustrates the different measured values for the data captured (see Number 1 within Figure 23).

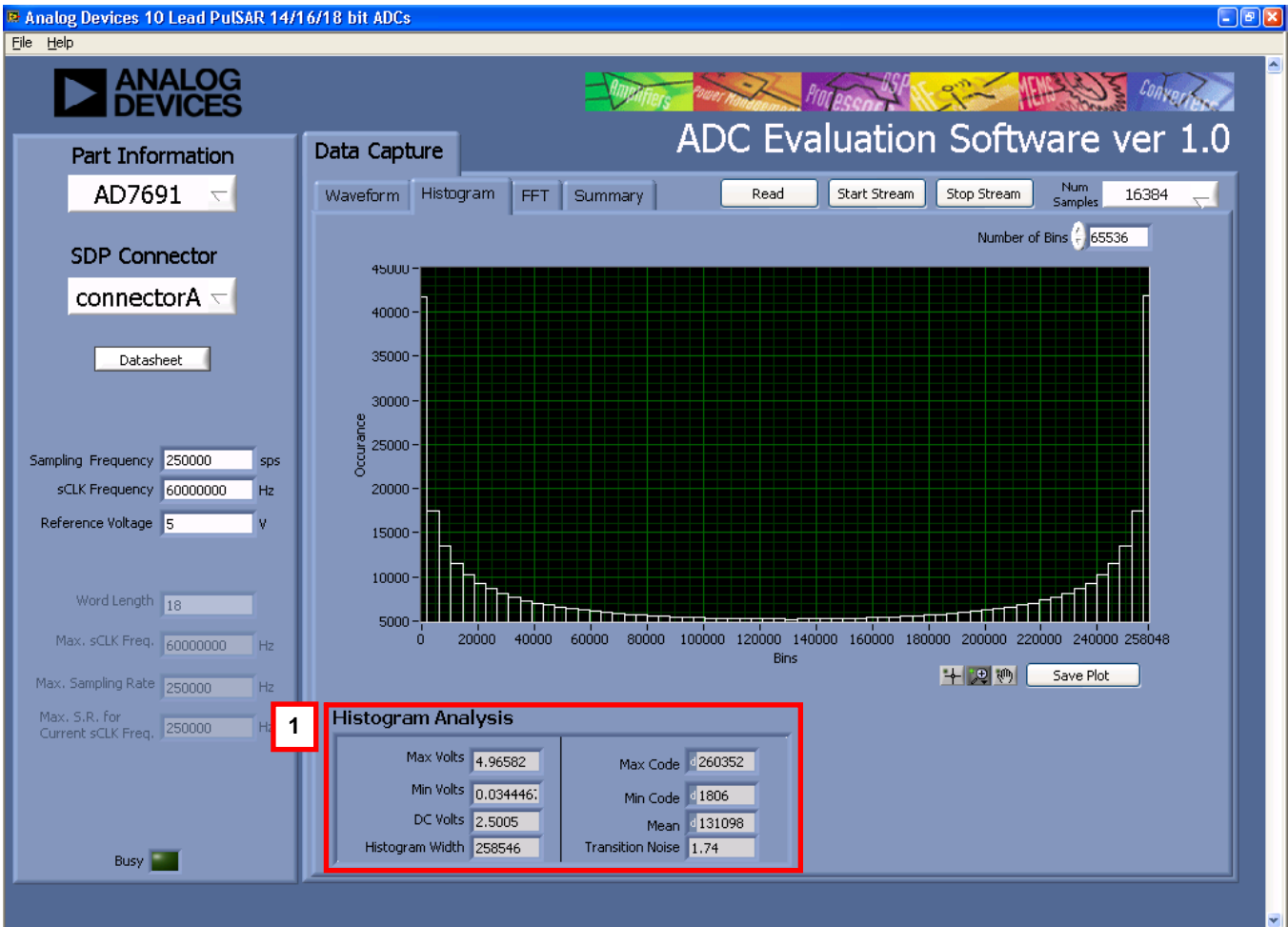

Figure 23. Histogram Tab, Histogram Captured for Sine Wave

**DC TESTING—HISTOGRAM**

More commonly, the histogram is used for dc testing where the user tests the ADC for the code distribution for dc input, computes the mean and standard deviation, or transition noise, of the converter, and displays the results. Raw data is captured and passed to the PC for statistical computations. To perform a histogram test, select **Histogram** and click **Start Stream**. Note that a histogram test can be performed without an external source because the evaluation board has a buffered  $V_{REF}/2$  source at the ADC input. To test other dc values, apply a source to the J6/J10 inputs. It may be required to filter the signal to make the dc source noise compatible with that of the ADC.

**AC TESTING—FFT CAPTURE**

This tests the traditional ac characteristics of the converter and displays an FFT of the result. As in the histogram test, raw data is captured and passed to the PC where the FFT is performed displaying signal-to-noise ratio (SNR), signal-to-noise-and-distortion ratio (SINAD), total harmonic distortion (THD),

and spurious-free dynamic range (SFDR). The data can also be displayed in the time domain. To perform an ac test, apply a sinusoidal signal to the evaluation board at the SMA inputs, J6/J10. Low distortion, better than 100 dB, is required to allow true evaluation of the device. One possibility is to filter the input signal from the ac source. A band-pass filter can be used, and its center frequency must match the test frequency of interest. Furthermore, if using a low frequency band-pass filter when the full-scale input range is more than a few V p-p, use the on-board amplifiers to amplify the signal, thus preventing the filter from distorting the input signal.

Figure 24 displays the histogram of the captured data that includes the following:

- The spectrum information
- The fundamental frequency and amplitude in addition to the second-to-fifth harmonics
- The performance data (SNR, dynamic range, THD, SINAD, and noise performance)

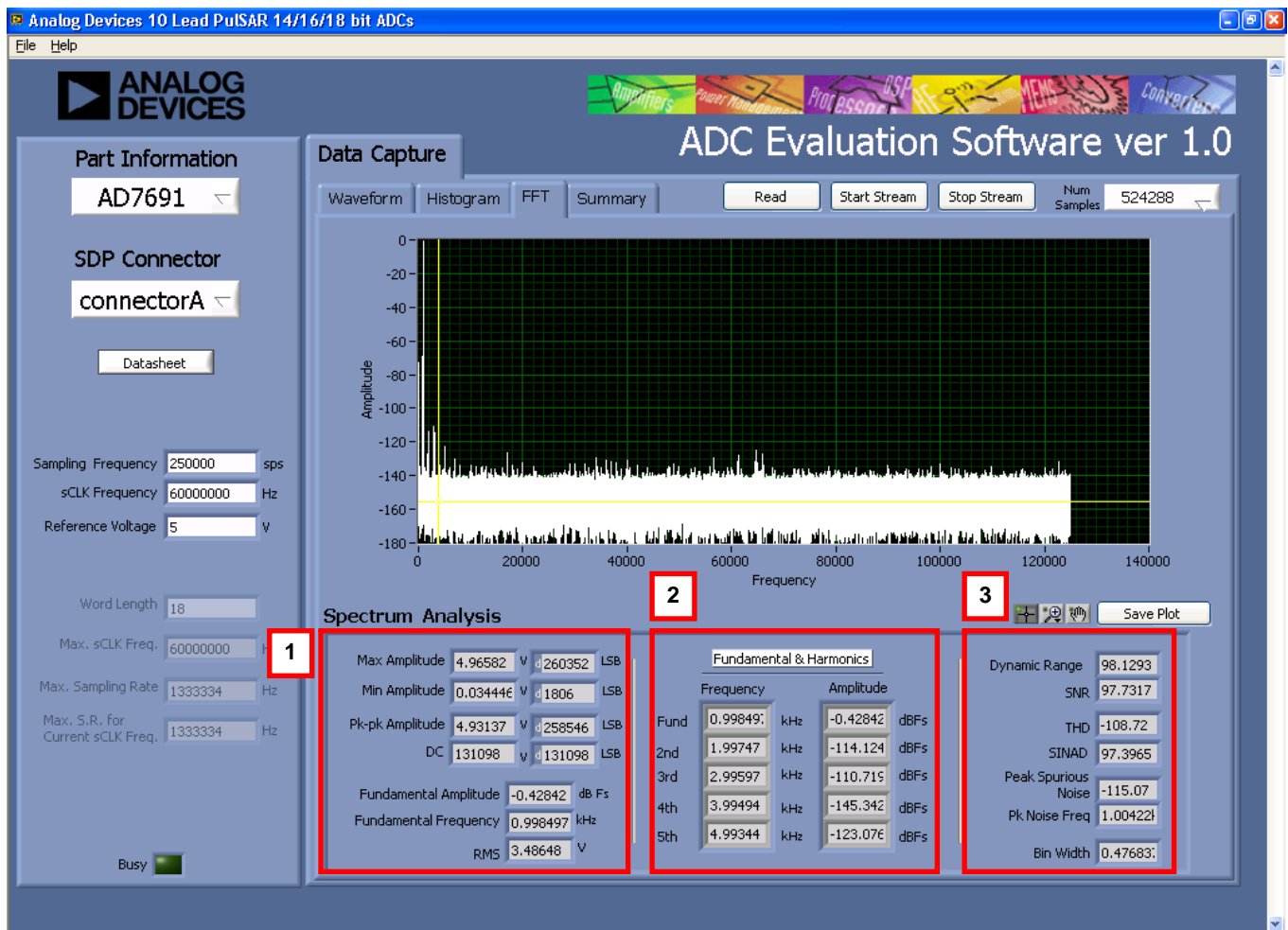

Figure 24. FFT Tab

**SUMMARY TAB**

The **Summary** tab captures all the display information and provides them in one panel with a synopsis of the information including key performance parameters, such as SNR and THD.

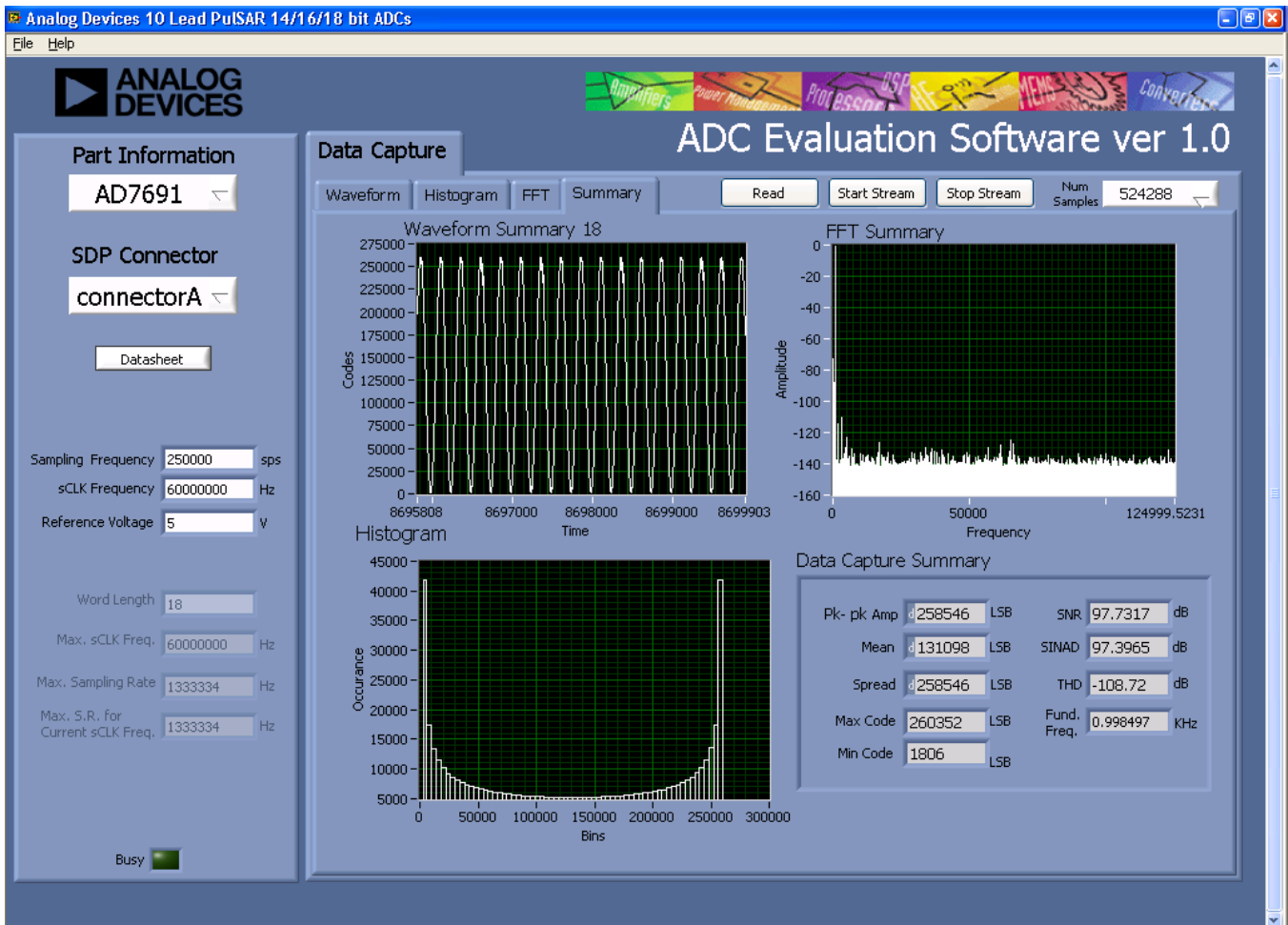

Figure 25. Summary Tab, Shows All Captured Windows

## SAVE FILE

The software can save the current captured data for later analysis, and the file format is .tsv (tab separated values).

The user is prompted with a **Choose or Enter Path of File** box (see Figure 26); save to an appropriate folder location.

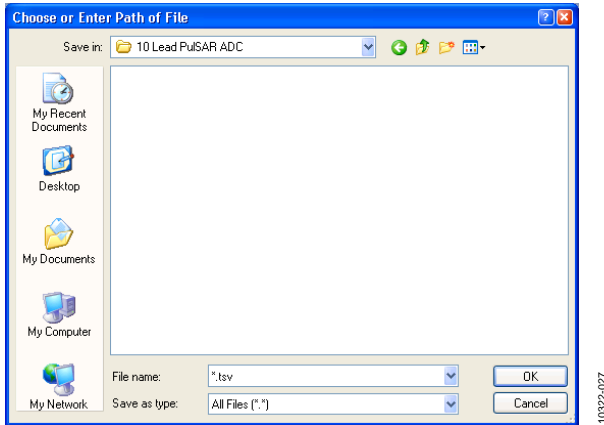

Figure 26. Save Dialog Box

## LOAD FILE

The user is prompted with a **Load File** box. The user may have to navigate to find these example files. The default location for the example files is **C:\Program Files\Analog Devices\8 & 10 Lead PulSAR ADCs\Example files**.

EVALUATION BOARD SCHEMATICS

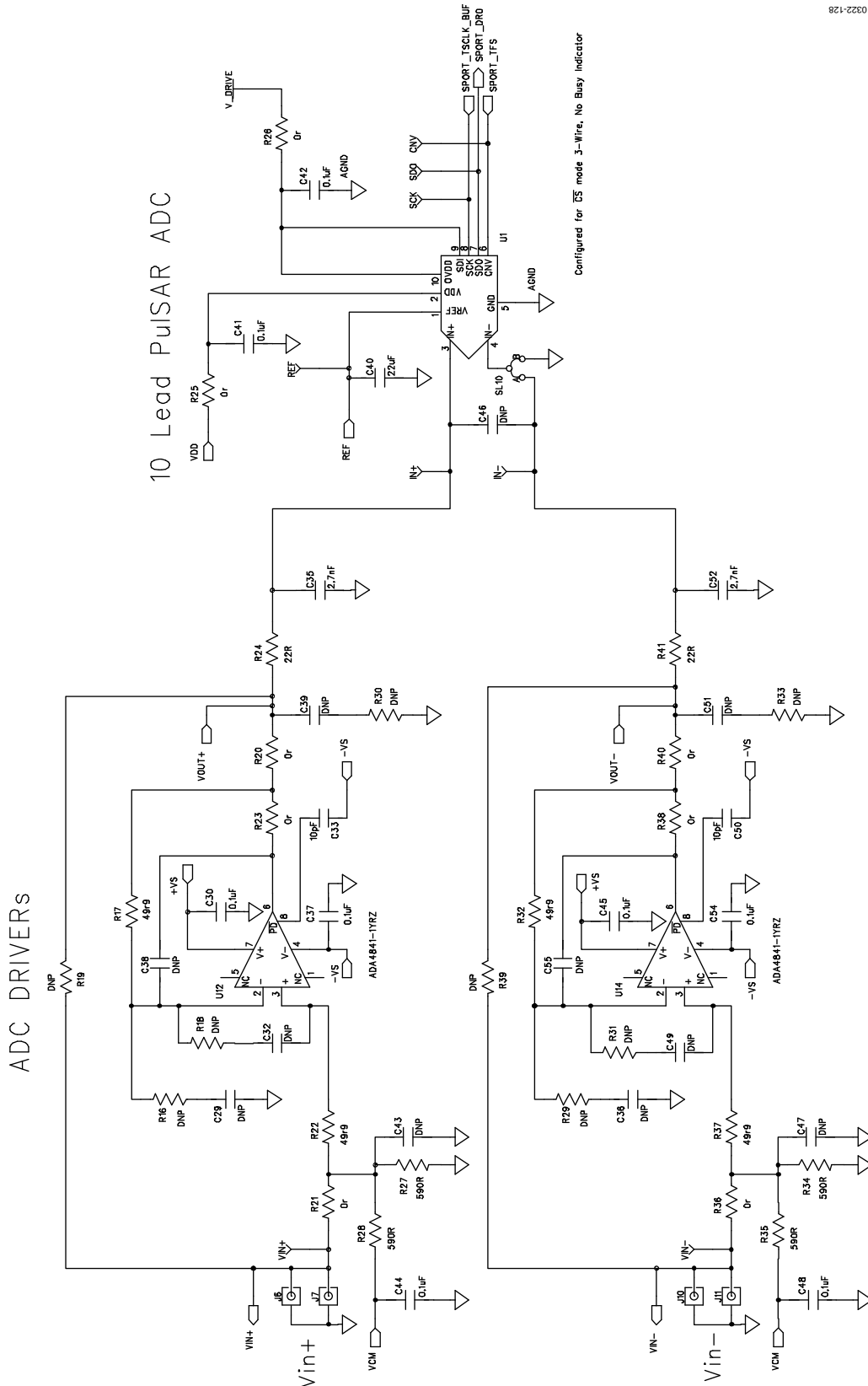

Figure 27. 10-Lead Evaluation Board, ADC and Driver

10322-228

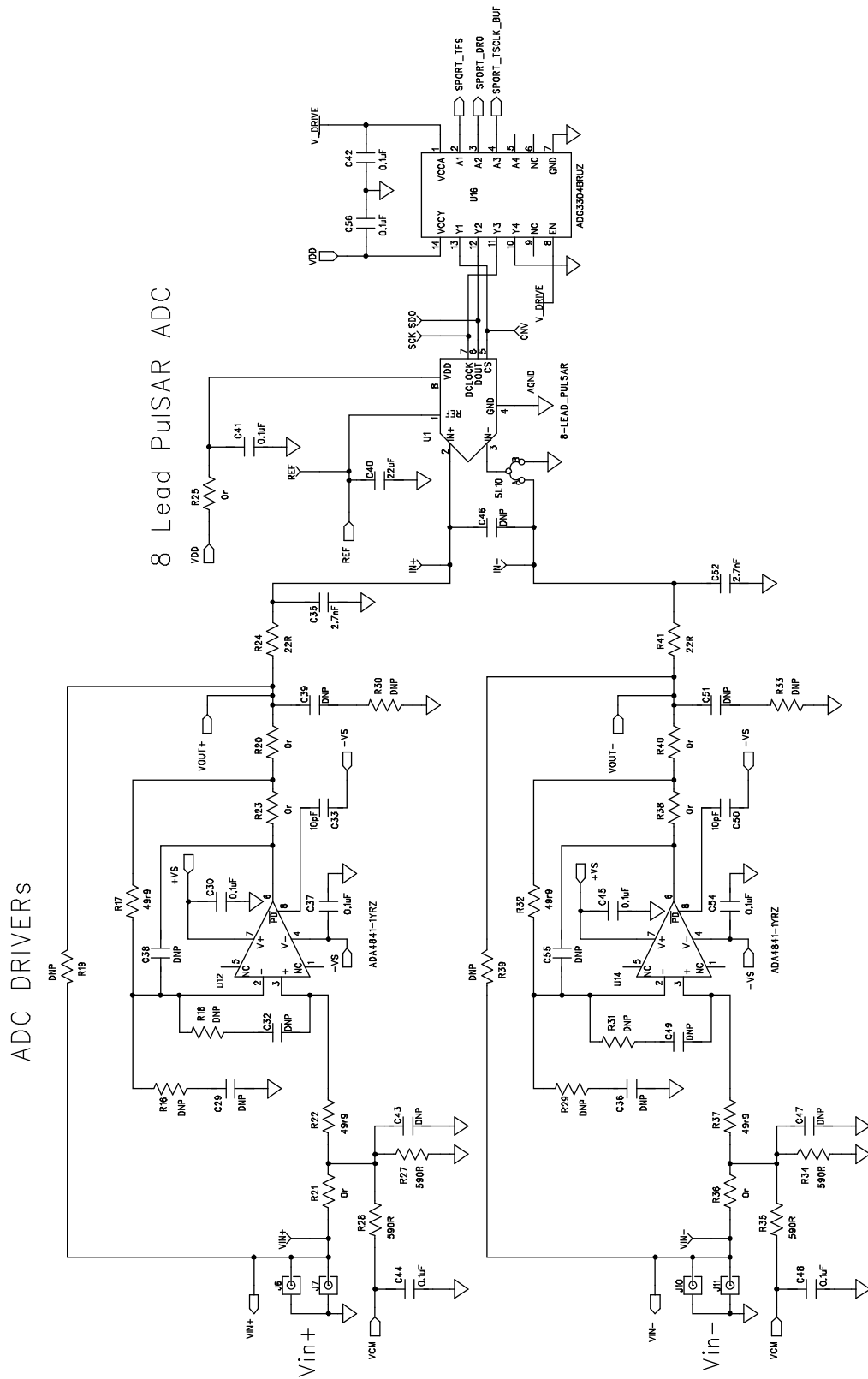

Figure 28. 8-Lead Evaluation Board, ADC and Driver

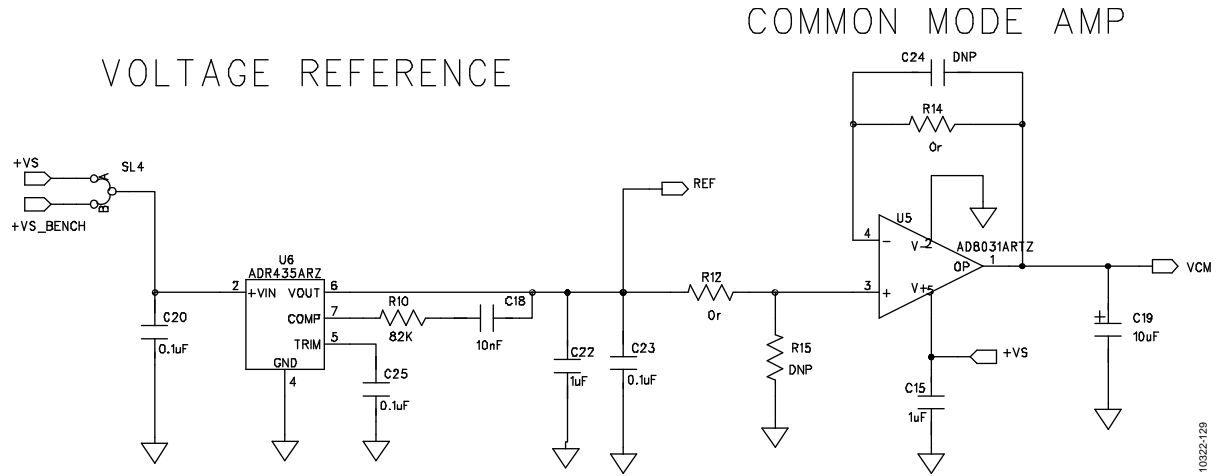

Figure 29. Voltage Reference and Common-Mode Buffer

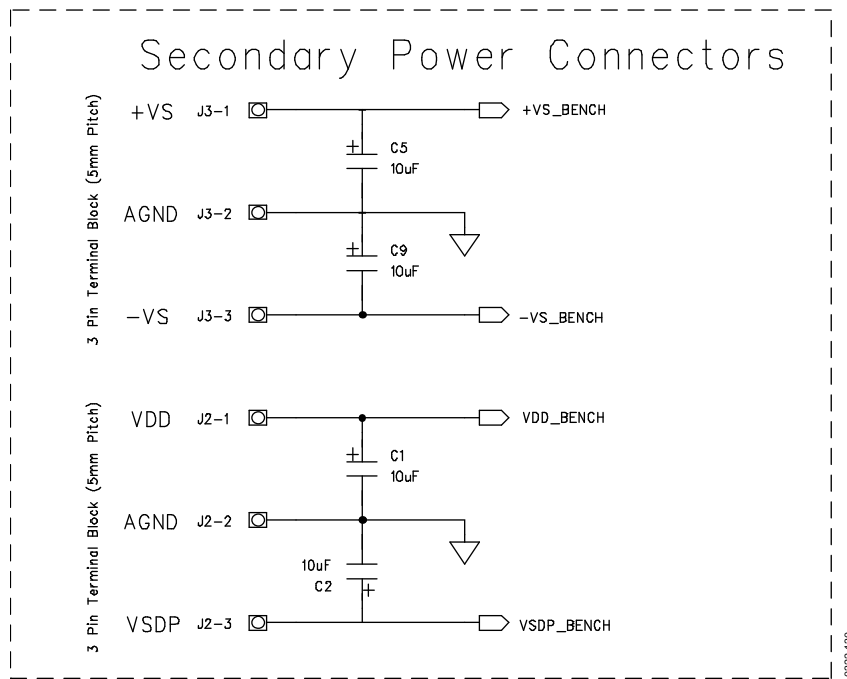

Figure 30. Secondary Power Connector for Bench Supply Purposes

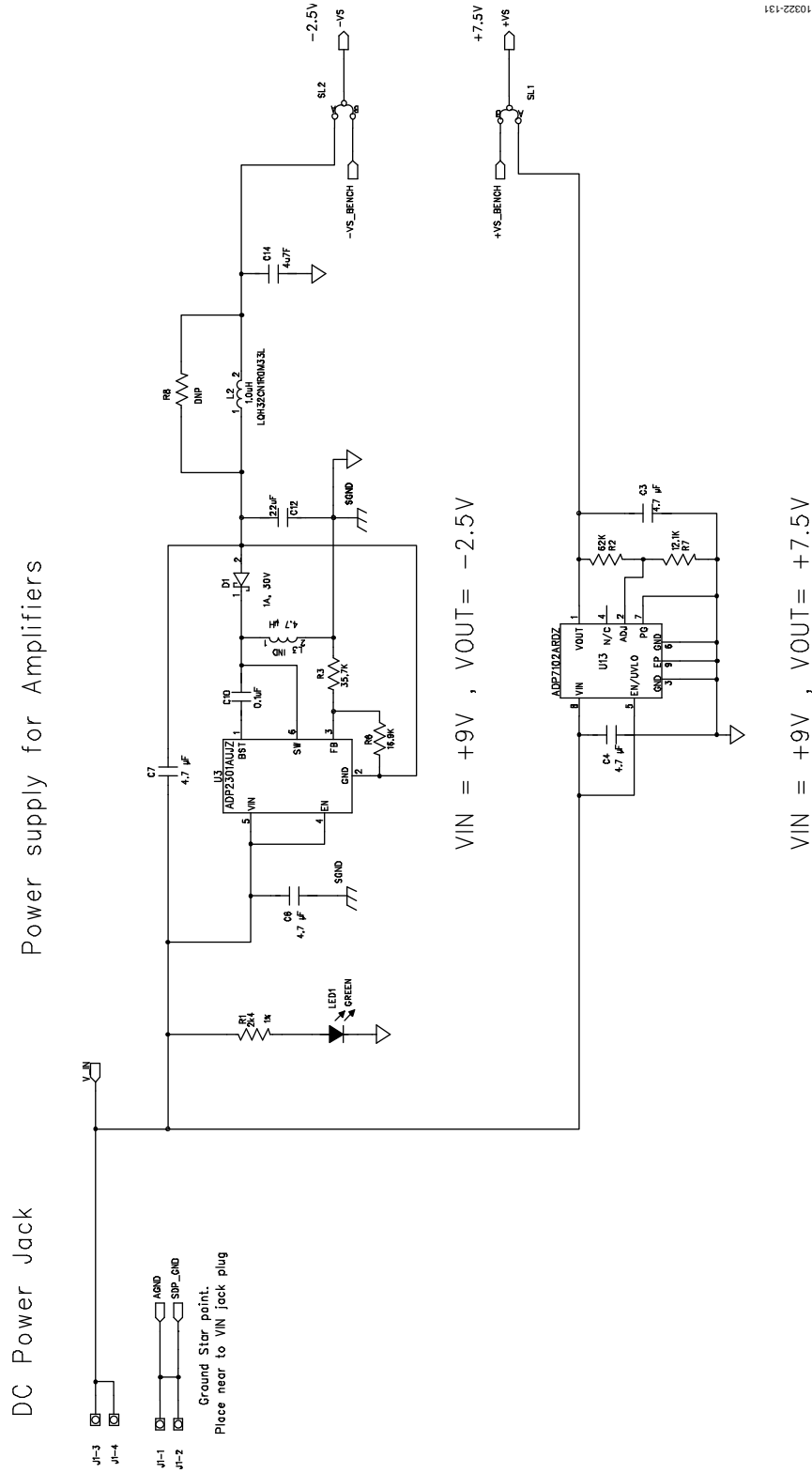
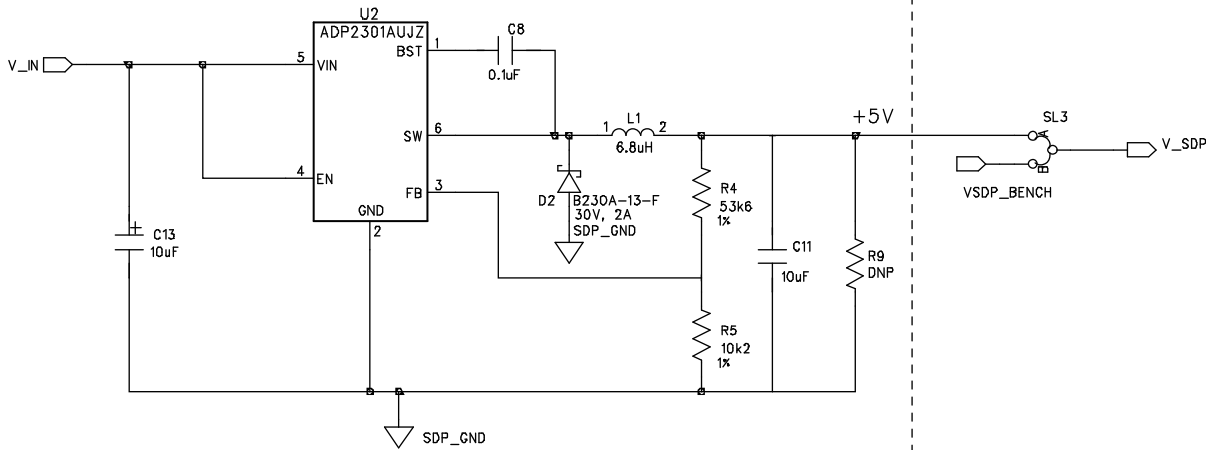

Figure 31. On-Board Amplifier Power Supply, +7.5/-2.5V

Power supply for SDP board



If supplying SDP from VSDP\_BENCH (SL8=B)  
VSDP\_BENCH needs to be limited to 5V max

Figure 32. SDP Power Supply

10322-132

Power Supply for ADC

This could be 5V or 2.5V LDO depending on ADC

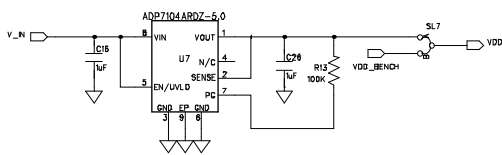

Power supply for V\_DRIVE

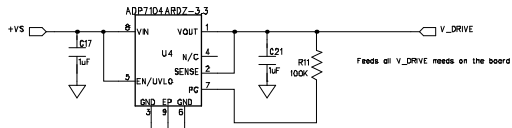
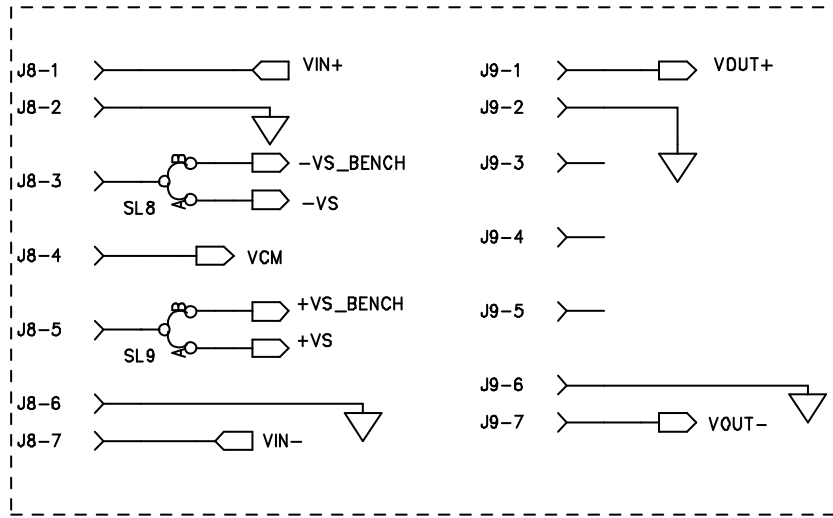

Figure 33. ADC/V\_DRIVE Power Supply

10322-133



## OPTIONAL HEADER CONNECTOR



## OPTIONAL HEADER CONNECTION EXTENDER CARD

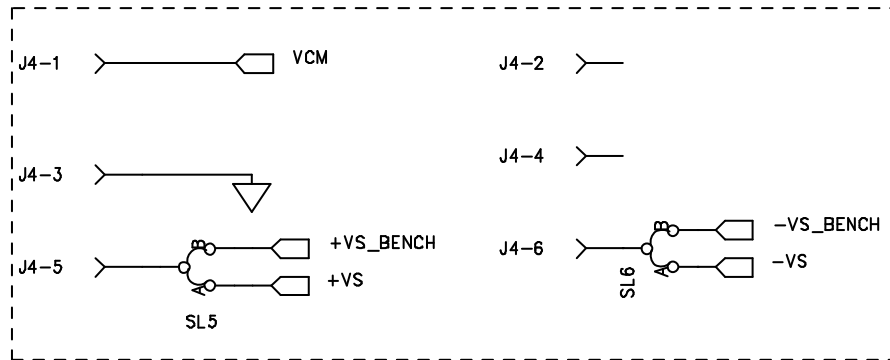

Figure 35. Header Connectors, Optional Connectors for Possible Add-On Boards

10332-135

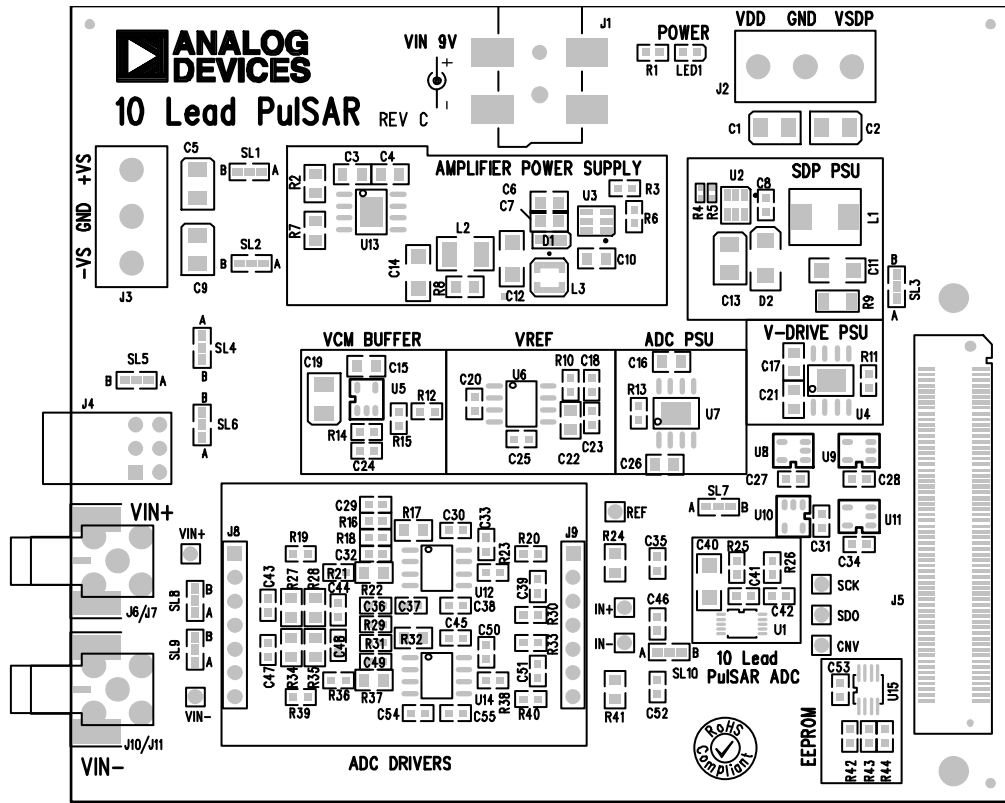

Figure 36. 10-Lead Evaluation Board Silkscreen, Top Layer

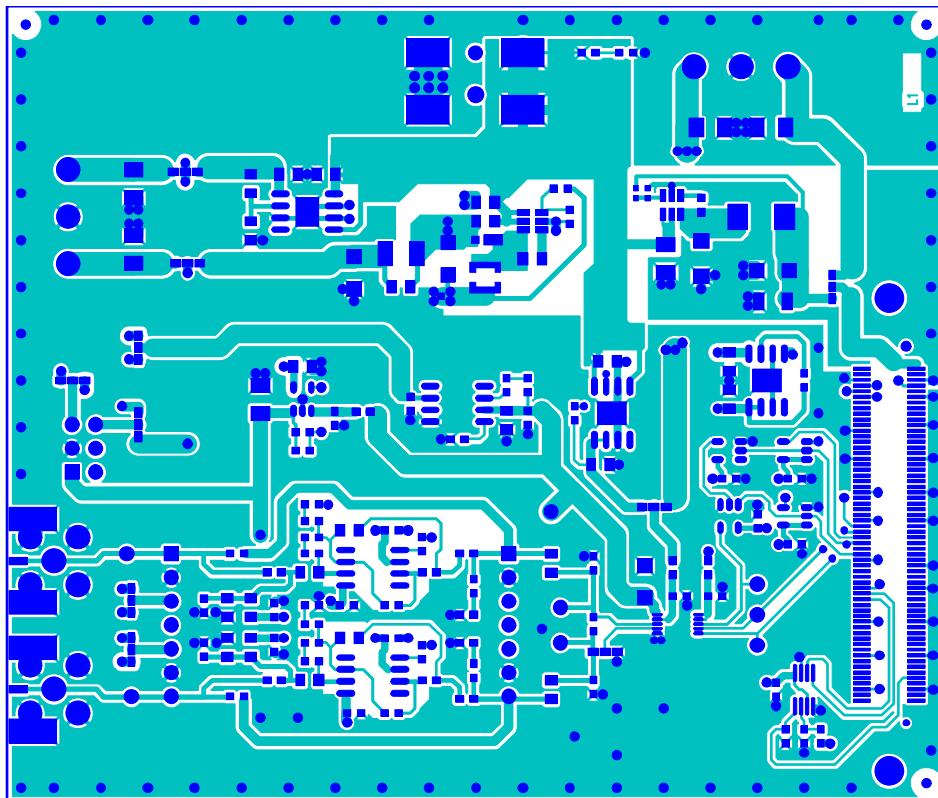
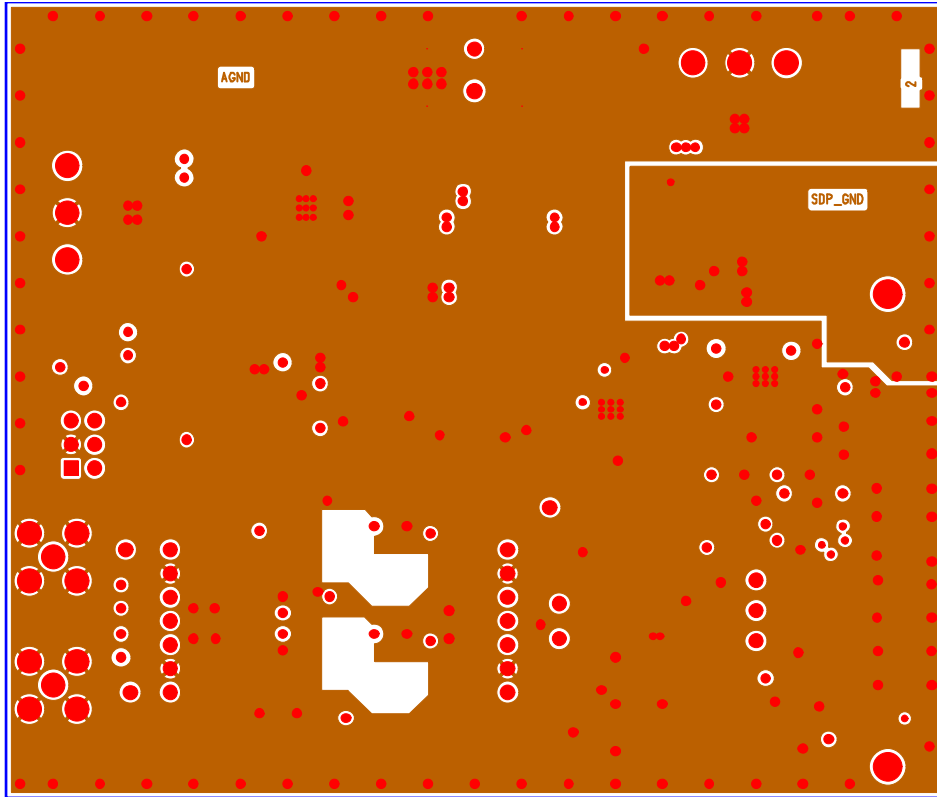
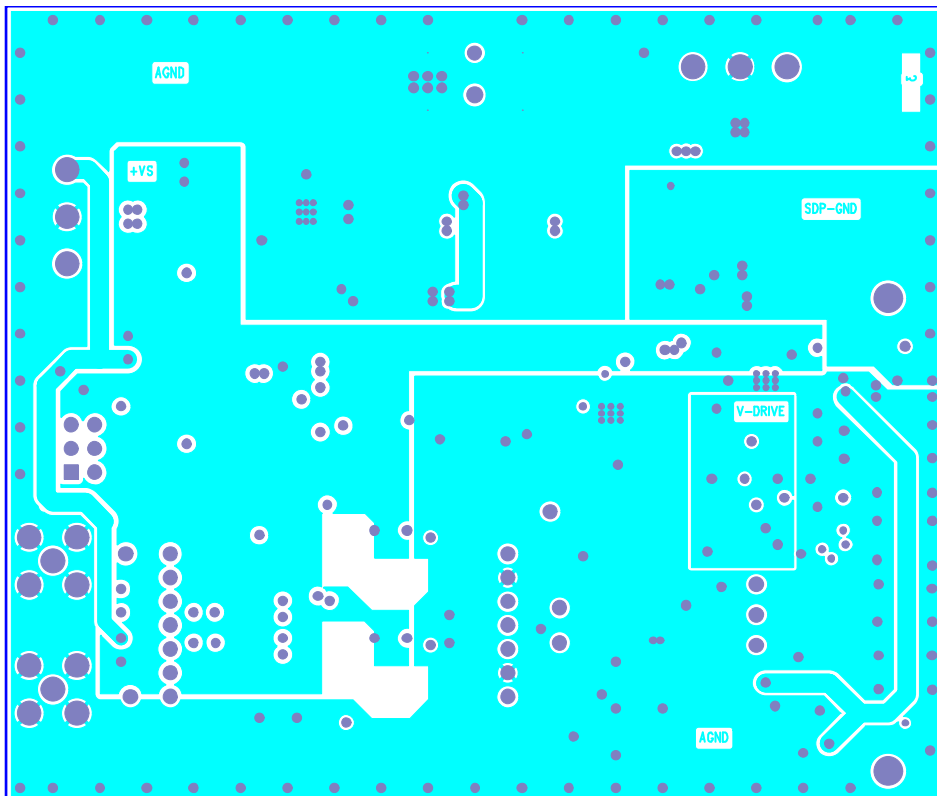

Figure 37. 10-Lead Evaluation Board, Layer 1



10322-138

Figure 38. 10-Lead Evaluation Board, Layer 2



10322-139

Figure 39. 10-Lead Evaluation Board, Layer 3

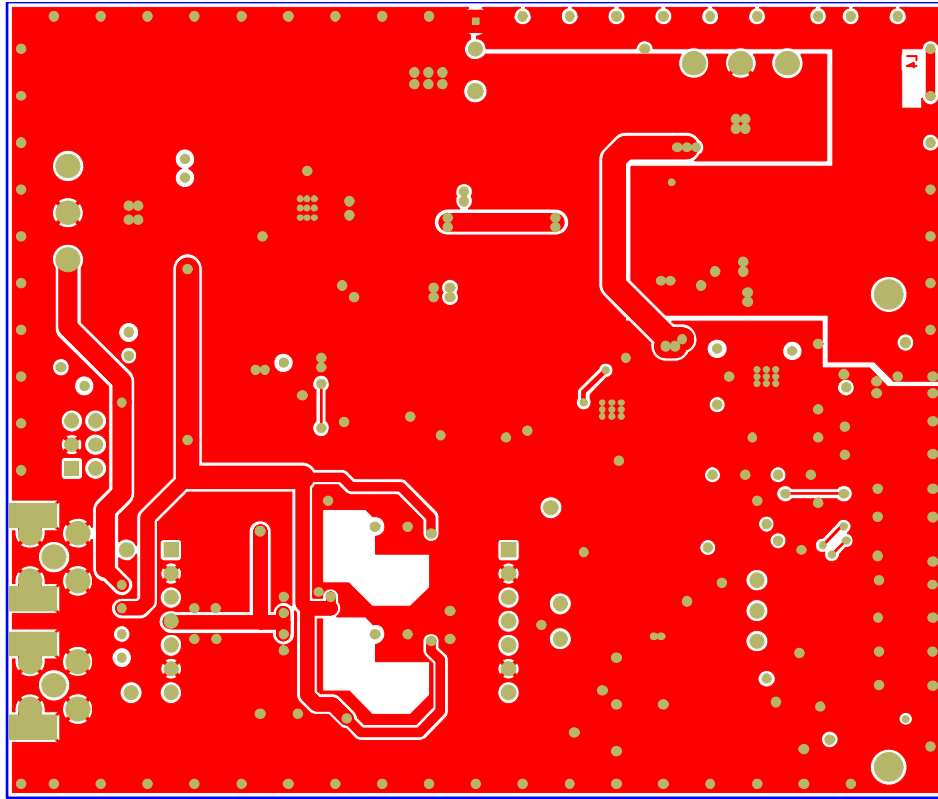

10322-140

Figure 40. 10-Lead Evaluation Board, Layer 4

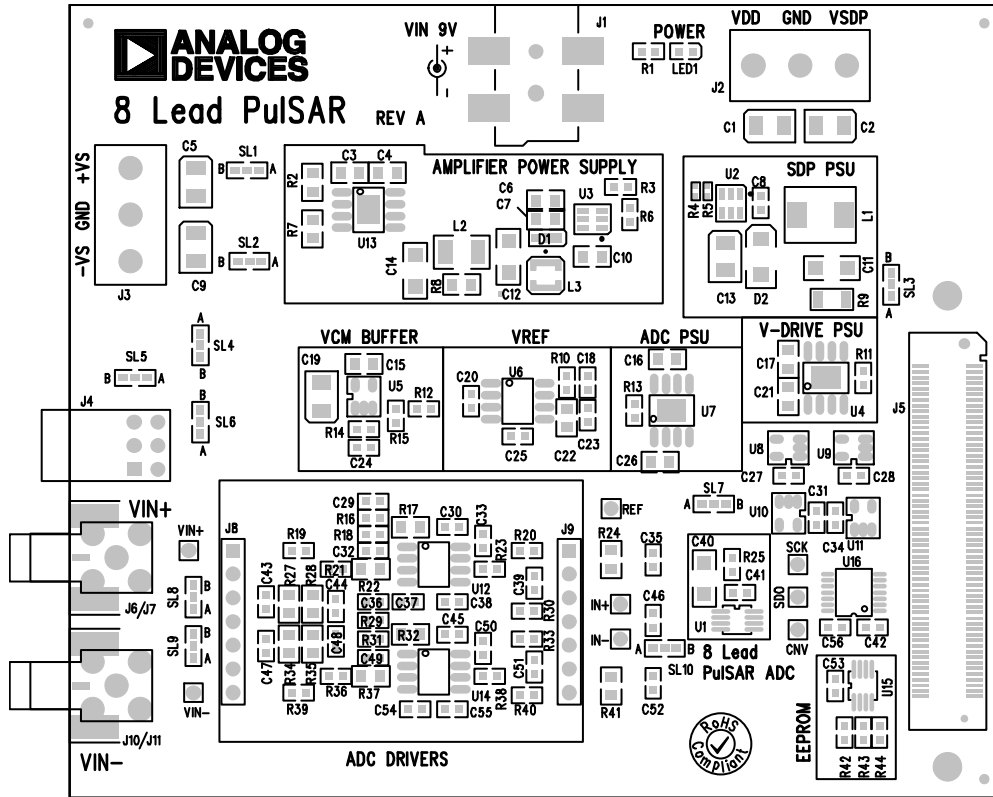

Figure 41. 8-Lead Evaluation Board Silkscreen, Top Layer

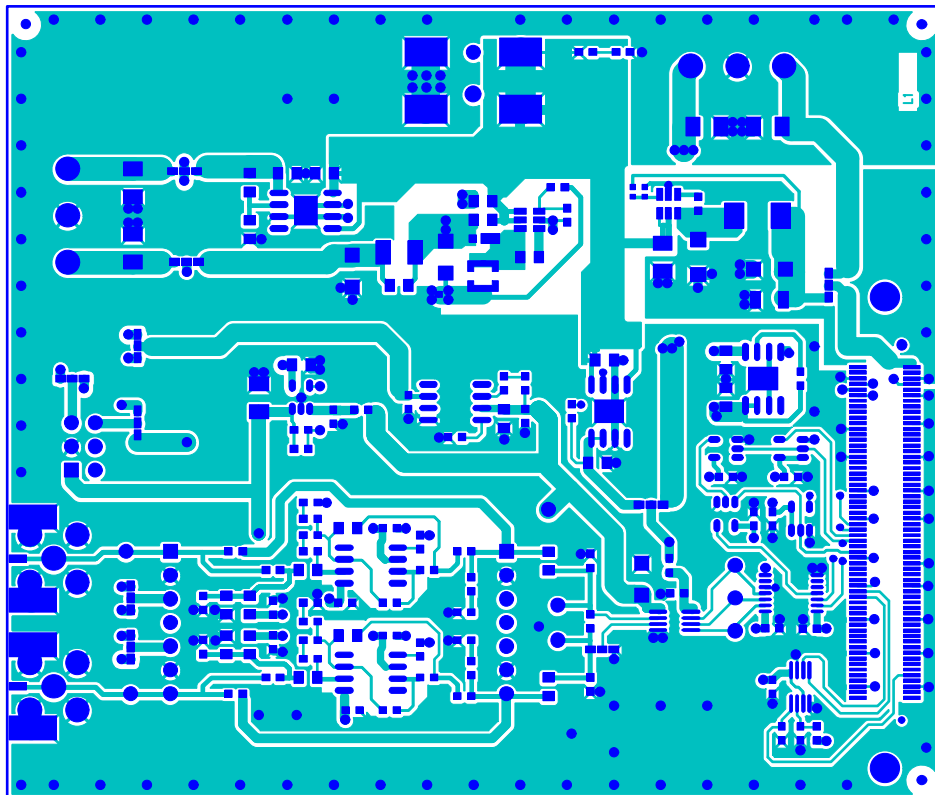

Figure 42. 8-Lead Evaluation Board, Layer 1

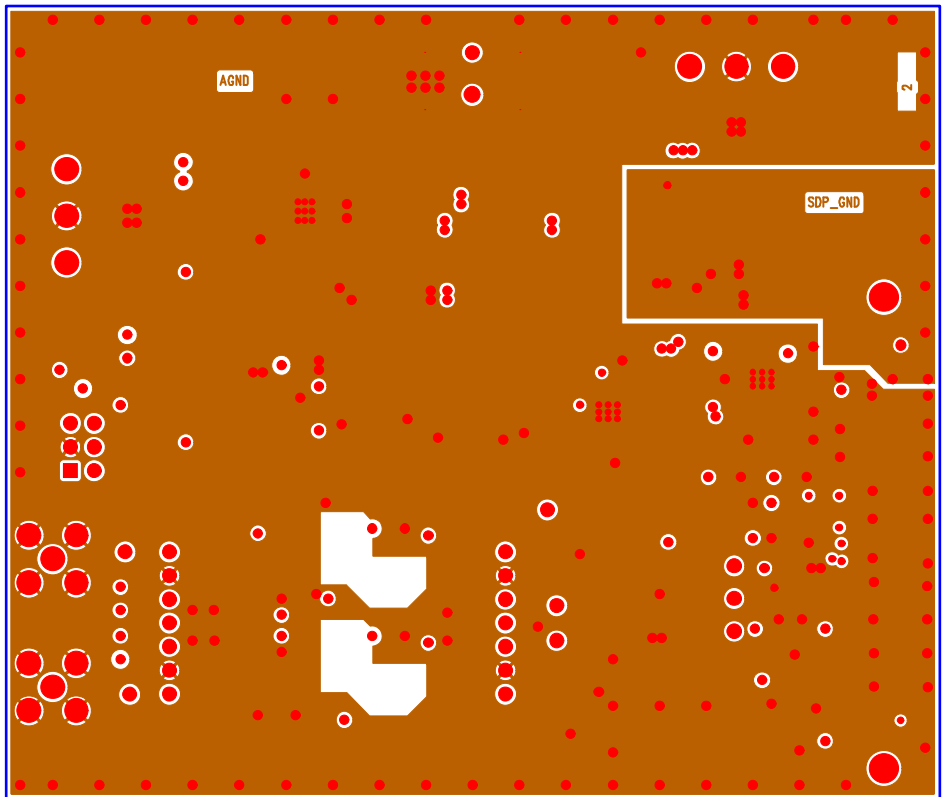

Figure 43. 8-Lead Evaluation Board, Layer 2

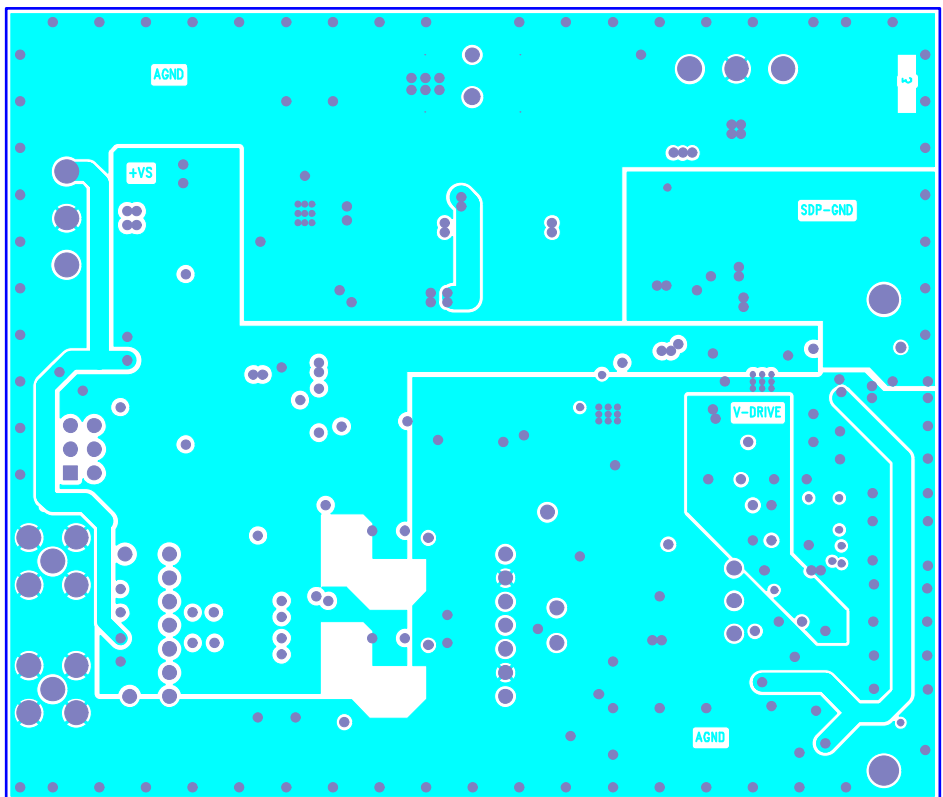

Figure 44. 8-Lead Evaluation Board, Layer 3

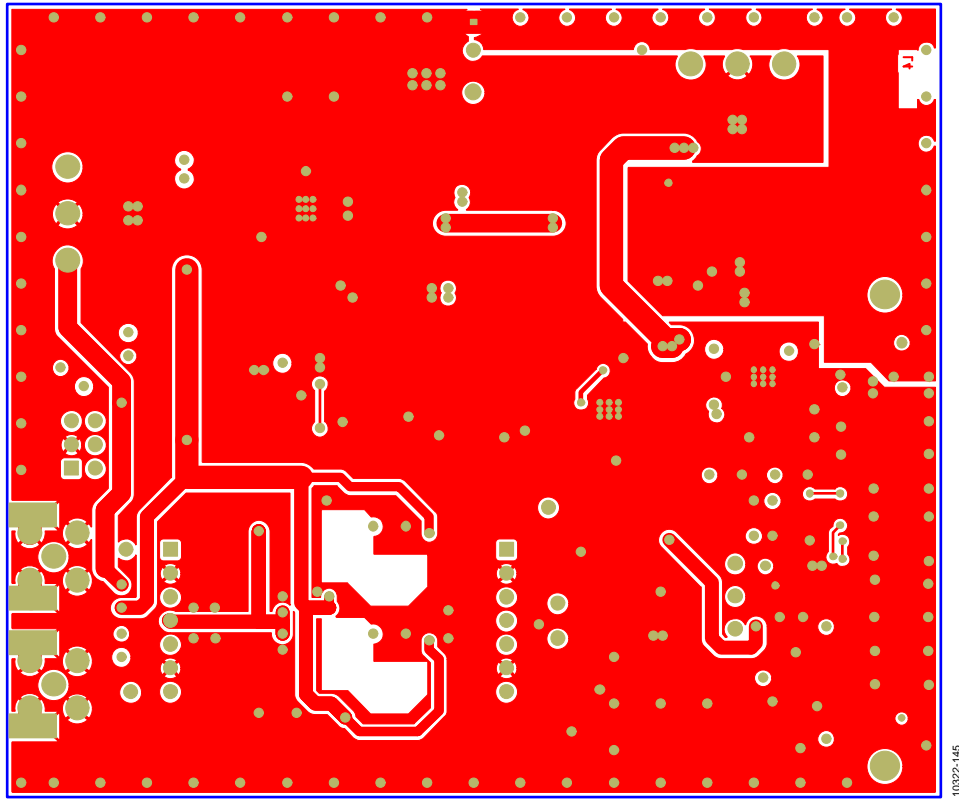

Figure 45. 8-Lead Evaluation Board, Layer 4

## TROUBLESHOOTING

### SOFTWARE

To troubleshoot the software, take the following steps:

1. Always install the software prior to connecting the hardware to the PC.
2. Always allow the install to fully complete (the software is a 2-part install, the ADC software and the SDP drivers). This may require a restart.
3. When the user first plugs in the SDP board via the USB cable provided, allow the new **Found Hardware Wizard** to run. This may take a little time but allow this to happen prior to starting the software.
4. Where the board does not appear to be functioning, ensure that the ADC evaluation board is connected to the SDP board and that the board is being recognized in the **Device Manager**, as shown in Figure 13.
5. If connected to a slower USB port where the SDP cannot read as quickly as it needs to, a timeout error may result. In this case, it is advised not to read continuously, or alternatively, to lower the number of samples taken.

### HARDWARE

To troubleshoot the hardware, take the following steps:

1. If the software does not read any data back, do the following:
  - a. Check that the power is applied within the power ranges described in the Power Supplies section.
  - b. Using a voltmeter, measure the voltage present at the positive terminal of C3 (it should be 7.5 V) and C14 (it should be -2.5 V) and measure the voltage at the positive terminal of C11 (it should be 5 V). The SDP board, LED1, should be lit.
  - c. Launch the software and read the data. If nothing happens, exit the software.
  - d. Power down the board and relaunch the software.
  - e. If no data is read back, confirm that the ADC evaluation board is connected to the SDP board and that the board is being recognized in the **Device Manager**, as shown in Figure 13.
2. When the user is working with the software in standalone/offline mode (no hardware connected) and later chooses to connect hardware, they must close and relaunch the software.

## PRODUCTS ON THIS EVALUATION BOARD

Table 5.

Product	Ordering Model	Sample Rate	Resolution (Bit)	Package Used on Evaluation Board
<a href="#">AD7683BRMZ</a>	<a href="#">EVAL-AD7683SDZ</a>	100 kSPS	16	8-Lead MSOP
<a href="#">AD7684BRMZ</a>	<a href="#">EVAL-AD7684SDZ</a>	100 kSPS	16	8-Lead MSOP
<a href="#">AD7685BRMZ</a>	<a href="#">EVAL-AD7685SDZ</a>	250 kSPS	16	10-Lead MSOP
<a href="#">AD7686BRMZ</a>	<a href="#">EVAL-AD7686SDZ</a>	500 kSPS	16	10-Lead MSOP
<a href="#">AD7687BRMZ</a>	<a href="#">EVAL-AD7687SDZ</a>	250 kSPS	16	10-Lead MSOP
<a href="#">AD7688BRMZ</a>	<a href="#">EVAL-AD7688SDZ</a>	500 kSPS	16	10-Lead MSOP
<a href="#">AD7690BRMZ</a>	<a href="#">EVAL-AD7690SDZ</a>	400 kSPS	18	10-Lead MSOP
<a href="#">AD7691BRMZ</a>	<a href="#">EVAL-AD7691SDZ</a>	250 kSPS	18	10-Lead MSOP
<a href="#">AD7693BRMZ</a>	<a href="#">EVAL-AD7693SDZ</a>	500 kSPS	16	10-Lead MSOP
<a href="#">AD7694BRMZ</a>	<a href="#">EVAL-AD7694SDZ</a>	250 kSPS	16	8-Lead MSOP
<a href="#">AD7942BRMZ</a>	<a href="#">EVAL-AD7942SDZ</a>	250 kSPS	14	10-Lead MSOP
<a href="#">AD7946BRMZ</a>	<a href="#">EVAL-AD7946SDZ</a>	500 kSPS	14	10-Lead MSOP
<a href="#">AD7980BRMZ</a>	<a href="#">EVAL-AD7980SDZ</a>	1 MSPS	16	10-Lead MSOP
<a href="#">AD7982BRMZ</a>	<a href="#">EVAL-AD7982SDZ</a>	1 MSPS	18	10-Lead MSOP
<a href="#">AD7983BRMZ</a>	<a href="#">EVAL-AD7983SDZ</a>	1.33 MSPS	16	10-Lead MSOP
<a href="#">AD7984BRMZ</a>	<a href="#">EVAL-AD7984SDZ</a>	1.33 MSPS	18	10-Lead MSOP
<a href="#">AD7988-5BRMZ</a>	<a href="#">EVAL-AD7988-5SDZ</a>	500 kSPS	16	10-Lead MSOP
<a href="#">AD7915BRMZ</a>	<a href="#">EVAL-AD7915SDZ</a>	1 MSPS	16	10-Lead MSOP
<a href="#">AD7916BRMZ</a>	<a href="#">EVAL-AD7916SDZ</a>	500 kSPS	16	10-Lead MSOP

## RELATED LINKS

Resource	Description
<a href="#">AD8031</a>	Product Page, <a href="#">AD8031</a> , 2.7 V, 800 $\mu$ A, 80 MHz Rail-to-Rail I/O Single Amplifier
<a href="#">ADA4841-1</a>	Product Page, <a href="#">ADA4841-1</a> , Low Power, Low Noise and Distortion, Rail-to-Rail Output Amplifier
<a href="#">ADR435</a>	Product Page, <a href="#">ADR435</a> , Ultralow Noise XFET <sup>®</sup> Voltage References with Current Sink and Source Capability
<a href="#">ADP7102</a>	Product Page, <a href="#">ADP7102</a> , 20 V, 300 mA, Low Noise, CMOS LDO
<a href="#">ADP7104</a>	Product Page, <a href="#">ADP7104</a> , 20 V, 500 mA, Low Noise, CMOS LDO
<a href="#">ADP2301</a>	Product Page, <a href="#">ADP2301</a> , 1.2 A, 20 V, 1.4 MHz Nonsynchronous Step-Down Switching Regulator
<a href="#">ADG3304</a>	Product Page, <a href="#">ADG3304</a> , Low Voltage 1.15 V to 5.5 V, 4 Channel, Bidirectional, Logic Level Translator
<a href="#">EVAL-SDP-CB1Z</a>	Product Page, System Demonstration Platform (SDP)
<a href="#">AN-931</a>	<a href="#">AN-931</a> Application Note, <i>Understanding PulSAR ADC Support Circuitry</i>

## NOTES

**ESD Caution**

**ESD (electrostatic discharge) sensitive device.** Charged devices and circuit boards can discharge without detection. Although this product features patented or proprietary protection circuitry, damage may occur on devices subjected to high energy ESD. Therefore, proper ESD precautions should be taken to avoid performance degradation or loss of functionality.

**Legal Terms and Conditions**

By using the evaluation board discussed herein (together with any tools, components documentation or support materials, the "Evaluation Board"), you are agreeing to be bound by the terms and conditions set forth below ("Agreement") unless you have purchased the Evaluation Board, in which case the Analog Devices Standard Terms and Conditions of Sale shall govern. Do not use the Evaluation Board until you have read and agreed to the Agreement. Your use of the Evaluation Board shall signify your acceptance of the Agreement. This Agreement is made by and between you ("Customer") and Analog Devices, Inc. ("ADI"), with its principal place of business at One Technology Way, Norwood, MA 02062, USA. Subject to the terms and conditions of the Agreement, ADI hereby grants to Customer a free, limited, personal, temporary, non-exclusive, non-sublicensable, non-transferable license to use the Evaluation Board FOR EVALUATION PURPOSES ONLY. Customer understands and agrees that the Evaluation Board is provided for the sole and exclusive purpose referenced above, and agrees not to use the Evaluation Board for any other purpose. Furthermore, the license granted is expressly made subject to the following additional limitations: Customer shall not (i) rent, lease, display, sell, transfer, assign, sublicense, or distribute the Evaluation Board; and (ii) permit any Third Party to access the Evaluation Board. As used herein, the term "Third Party" includes any entity other than ADI, Customer, their employees, affiliates and in-house consultants. The Evaluation Board is NOT sold to Customer; all rights not expressly granted herein, including ownership of the Evaluation Board, are reserved by ADI. CONFIDENTIALITY. This Agreement and the Evaluation Board shall all be considered the confidential and proprietary information of ADI. Customer may not disclose or transfer any portion of the Evaluation Board to any other party for any reason. Upon discontinuation of use of the Evaluation Board or termination of this Agreement, Customer agrees to promptly return the Evaluation Board to ADI. ADDITIONAL RESTRICTIONS. Customer may not disassemble, decompile or reverse engineer chips on the Evaluation Board. Customer shall inform ADI of any occurred damages or any modifications or alterations it makes to the Evaluation Board, including but not limited to soldering or any other activity that affects the material content of the Evaluation Board. Modifications to the Evaluation Board must comply with applicable law, including but not limited to the RoHS Directive. TERMINATION. ADI may terminate this Agreement at any time upon giving written notice to Customer. Customer agrees to return to ADI the Evaluation Board at that time. LIMITATION OF LIABILITY. THE EVALUATION BOARD PROVIDED HEREUNDER IS PROVIDED "AS IS" AND ADI MAKES NO WARRANTIES OR REPRESENTATIONS OF ANY KIND WITH RESPECT TO IT. ADI SPECIFICALLY DISCLAIMS ANY REPRESENTATIONS, ENDORSEMENTS, GUARANTEES, OR WARRANTIES, EXPRESS OR IMPLIED, RELATED TO THE EVALUATION BOARD INCLUDING, BUT NOT LIMITED TO, THE IMPLIED WARRANTY OF MERCHANTABILITY, TITLE, FITNESS FOR A PARTICULAR PURPOSE OR NON-INFRINGEMENT OF INTELLECTUAL PROPERTY RIGHTS. IN NO EVENT WILL ADI AND ITS LICENSORS BE LIABLE FOR ANY INCIDENTAL, SPECIAL, INDIRECT, OR CONSEQUENTIAL DAMAGES RESULTING FROM CUSTOMER'S POSSESSION OR USE OF THE EVALUATION BOARD, INCLUDING BUT NOT LIMITED TO LOST PROFITS, DELAY COSTS, LABOR COSTS OR LOSS OF GOODWILL. ADI'S TOTAL LIABILITY FROM ANY AND ALL CAUSES SHALL BE LIMITED TO THE AMOUNT OF ONE HUNDRED US DOLLARS (\$100.00). EXPORT. Customer agrees that it will not directly or indirectly export the Evaluation Board to another country, and that it will comply with all applicable United States federal laws and regulations relating to exports. GOVERNING LAW. This Agreement shall be governed by and construed in accordance with the substantive laws of the Commonwealth of Massachusetts (excluding conflict of law rules). Any legal action regarding this Agreement will be heard in the state or federal courts having jurisdiction in Suffolk County, Massachusetts, and Customer hereby submits to the personal jurisdiction and venue of such courts. The United Nations Convention on Contracts for the International Sale of Goods shall not apply to this Agreement and is expressly disclaimed.

©2012–2015 Analog Devices, Inc. All rights reserved. Trademarks and registered trademarks are the property of their respective owners.  
UG10322-0-3/15(C)



[www.analog.com](http://www.analog.com)

## Looking for pricing, stock, or lifecycle information?

Click below to explore more details on WIN SOURCE:

- ⊖ [View EVAL-AD7688-PMDZ on WIN SOURCE](#)
- ⊖ [Analog Devices Inc. Information](#)

## Optimize Your Supply Chain with WIN SOURCE Solutions

- ✓ Global Sourcing Solution
- ✓ Obsolete Management
- ✓ Cost Control Management
- ✓ Shortage Management
- ✓ Alternative Solution
- ✓ Excess Inventory Management