



**THE DATASHEET OF
EVAL-ADIN1200FMCZ**



Evaluating the **ADIN1200** Robust, Industrial, Low Power, 10 Mbps and 100 Mbps Ethernet PHY

FEATURES

- FMC connector for MII interface, MDIO signals, and status signals**
- Accessible, surface-mount configuration resistors and dial switches**
- Operates from a single, external, 5 V supply**

EVALUATION KIT CONTENTS

- 2 EVAL-ADIN1200FMCZ evaluation boards**
- 2 MDIO interface dongles**

EQUIPMENT NEEDED

- 5 V power supply rail to connect to EXT_5V connector or 5 V barrel adapter to connect to P4 plug**
- Ethernet cable**
- USB cable**
- PC running Windows 7 and upward**

SOFTWARE NEEDED

- Ethernet PHY software and GUI (available to download on the [ADIN1200](#) product page)**

DOCUMENTS NEEDED

- [ADIN1200](#) data sheet

GENERAL DESCRIPTION

The EVAL-ADIN1200FMCZ allows simplified evaluation of the key features of the [ADIN1200](#) robust, industrial, low power 10 Mbps and 100 Mbps Ethernet physical layer (PHY). The EVAL-ADIN1200FMCZ is powered by a single, external, 5 V supply rail that can be supplied either via the EXT_5V connector or via the P4 plug.

All chip supplies are regulated from the 5 V rail providing supply rails required for AVDD_3P3 and VDDIO.

The P3 field programmable gate array (FPGA) mezzanine card (FMC) connector is provided for connection to a master FPGA system for the media access control (MAC) interface and management data input/output (MDIO) control. The P5 connector provides an alternative means for MDIO control. The EVAL-ADIN1200FMCZ is fitted with a 25 MHz crystal (Y1).

For complete specifications for the [ADIN1200](#) device, see the [ADIN1200](#) data sheet, which must be consulted in conjunction with this user guide when using the EVAL-ADIN1200FMCZ.

TABLE OF CONTENTS

Features	1	Link Properties Tab.....	11
Evaluation Kit Contents.....	1	Register Access Tab	12
Equipment Needed.....	1	Clock Pin Control Tab	13
Software Needed.....	1	Loopback Tab.....	13
Documents Needed.....	1	Test Modes Tab	13
General Description	1	FrameGenerator/Checker	13
Revision History	2	Cable Diagnostics Tab	14
EVAL-ADIN1200FMCZ with Optional MDIO Interface Dongle Connected.....	3	Activity Information Window and Linking Status	15
Evaluation Board Hardware.....	4	Activity Log Information Section	15
Power Supplies	4	Loading a Script File	15
Power Sequencing	4	Troubleshooting.....	17
Evaluation Board Usage Options	4	Software Installation Tips.....	17
Jumper Options	4	Software Tips	17
Clock Options	4	Hardware Tips	17
On-Board EEPROM and LEDs	5	Layout Guidelines.....	18
ADIN1200 LED Pin	5	Board Stackup.....	18
MDIO Interface	5	Ground Planes	18
MDIO Interface Dongle	5	Isolation Guidelines	18
Configuration Pins Setup	6	Power Supply Decoupling.....	18
Software Overview	8	MAC Interface	18
Installing the Ethernet PHY Software	8	Management Interface.....	18
Initial Setup	9	Placement of the TVS Diode	18
Using the Evaluation Software	10	Thermal Considerations.....	18
Board Display Showing Connected EVAL-ADIN1200FMCZ Hardware	11	Evaluation Board Schematics and Artwork.....	19
User Buttons Section.....	11	Ordering Information.....	26
		Bill of Materials.....	26

REVISION HISTORY

11/2019—Revision 0: Initial Version

EVAL-ADIN1200FMCZ WITH OPTIONAL MDIO INTERFACE DONGLE CONNECTED

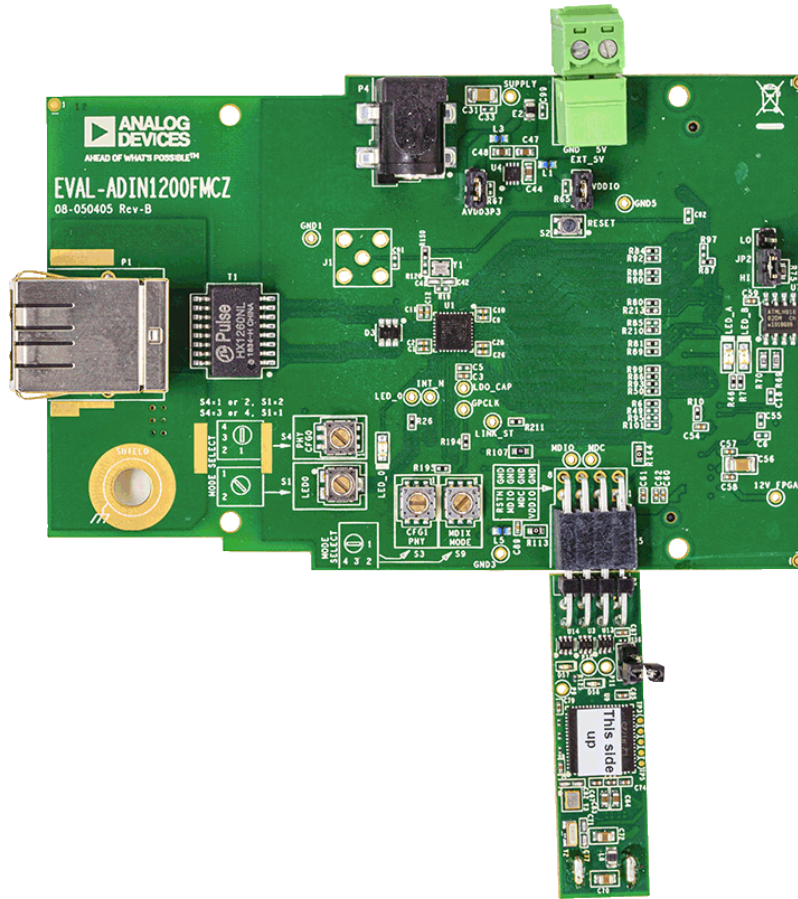

Figure 1.

22009-001

EVALUATION BOARD HARDWARE

POWER SUPPLIES

The EVAL-ADIN1200FMCZ operates from a single, external supply rail.

Apply 5 V either to the P4 plug or to the EXT_5V connector with the JP3 jumper configured for 5 V at Position A.

The rest of the EVAL-ADIN1200FMCZ power requirements are generated from the 5 V supply. The on-board [ADP223](#) device generates the AVDD_3P3 and VDDIO power rails. The default nominal voltages are listed in Table 1.

The VDDIO voltage rail defaults to 2.5 V with the installed components, and can be adjusted if other VDDIO voltages are required by changing the value of the R16 resistor accordingly, as shown in Table 1.

Table 1. Default Device Power Supply Configuration

Supply Rail	Nominal Voltage	Adjustment
AVDD_3P3	3.3 V	Not applicable
VDDIO	2.5 V	1.8 V with R16 = 130 kΩ 2.5 V with R16 = 200 kΩ 3.3 V with R16 = 280 kΩ

Table 2 shows an overview of the EVAL-ADIN1200FMCZ current for various operating modes.

Table 2. EVAL-ADIN1200FMCZ Quiescent Current (EXT_5V = 5 V)

Board Status	Typical Quiescent Current
On Power-Up	30 mA initially 6.5 mA in energy detect power down (EDPD) mode
In Hardware Power-Down (RESET_N Held Low)	6.5 mA
10BASE-TX	50 mA
100BASE-TX	60 mA

POWER SEQUENCING

There are no power sequencing requirements for the [ADIN1200](#) device.

When using the EVAL-ADIN1200FMCZ with the MDIO interface dongle, there is a known sequence requirement for the MDIO interface dongle. It is recommended that the MDIO interface dongle be powered from the USB prior to connection to the EVAL-ADIN1200FMCZ. Alternatively, if issues are observed, restart the graphical user interface (GUI) software to resolve any board connection issues.

EVALUATION BOARD USAGE OPTIONS

The EVAL-ADIN1200FMCZ can be used in two general modes. In standalone mode, the EVAL-ADIN1200FMCZ can be used to evaluate the [ADIN1200](#) in IEEE 802.3 test modes, establish links with a link partner, and evaluate the performance of the

chip. In standalone mode, power the EVAL-ADIN1200FMCZ with a 5 V supply at the EXT_5V connector.

Alternatively, the EVAL-ADIN1200FMCZ has an FMC low pin count (LPC) connector that can be plugged into an FPGA development board. When used with an FPGA board, the media independent interfaces (MIIs), clocks, and light emitting diodes (LEDs) can be connected to the FPGA board where the MAC and upper layers can be implemented for evaluation of the [ADIN1200](#) in a full system.

JUMPER OPTIONS

A minimal number of jumpers on the EVAL-ADIN1200FMCZ must be set for the required operating setup before using the EVAL-ADIN1200FMCZ for evaluation. The functions and default settings of these jumper options are described in Table 3.

Table 3. Default Jumper Options

Link	Position	Function
JP2	B (high)	This jumper sets the write mode of U7. Position A (low): enable writing to the electrically erasable programmable read only memory (EEPROM) Position B (high): write protect the EEPROM (default)
AVDD3P3	Inserted	Nominal 3.3 V
VDDIO	Inserted	Nominal 2.5 V

CLOCK OPTIONS

The EVAL-ADIN1200FMCZ provides the option to supply the [ADIN1200](#) clock requirements from either an on-board crystal oscillator or an external clock applied to the J1 connector.

The crystal oscillators on the EVAL-ADIN1200FMCZ and the MDIO interface dongle include the following:

- Y1 is a 25 MHz crystal connected across the XTAL_I/CLK_IN/REF_CLK pin and XTAL_O pin of the [ADIN1200](#) on the EVAL-ADIN1200FMCZ.
- Y2 is a 32.768 kHz crystal used on the MDIO interface dongle for the on-board [ADuCM3029](#).
- Y3 is a 26 MHz crystal used on the MDIO interface dongle for the on-board [ADuCM3029](#).

When a 25 MHz external clock is applied to the J1 connector, the R120 resistor must be populated and the Y1 crystal must be removed if the signal applied to J1 is used by the [ADIN1200](#). The 25 MHz clock must be a sine or square wave signal with an input range of 1.8 V to 2.5 V. See the [ADIN1200](#) data sheet for more information.

ON-BOARD EEPROM AND LEDs

The EVAL-ADIN1200FMCZ has two FPGA controllable LEDs and one unprogrammed, I²C EEPROM, U7.

U7 can be programmed with voltage settings to allow the FPGA board to provide the correct voltages on the supply rails. The binary write address of the EEPROM is 10100 GA1 GA0 0 and the read address is 10100 GA1 GA0 1. GA0 and GA1 are nodes on the schematic for the FMC connector.

ADIN1200 LED PIN

There is one LED pin (LED_0) on the ADIN1200. The LED_0 pin can be configured in various operating modes using the MDIO interface dongle (see the ADIN1200 data sheet). By default, the LED_0 pin LED illuminates when a link is established, and flashes when there is activity.

The LED_0 pin is a multifunction pin shared with the PHY_CFG0 function. Therefore, it can be necessary for the voltage level on the LED_0 pin to be set at a certain value at power-on and reset to configure the ADIN1200 as required. See the ADIN1200 data sheet for more information on the multilevel strapping being used as part of the hardware configuration.

The LED_0 pin has a two-pole rotary switch, S1, to allow easy configuration for all modes of the PHY_CFG0 pin (as set by S4). Table 4 describes the configuration of S1 for the appropriate PHY_CFG0 (S4) pin setting. The LED_0 pin is driven from the AVDD3P3 supply rail (see Figure 2).

Table 4. S1 Switch Positions

Jumper	S4, PHY_CFG0	S1 Position
JP1	Mode 3 and Mode 4	1
JP2	Mode 1 and Mode 2	2

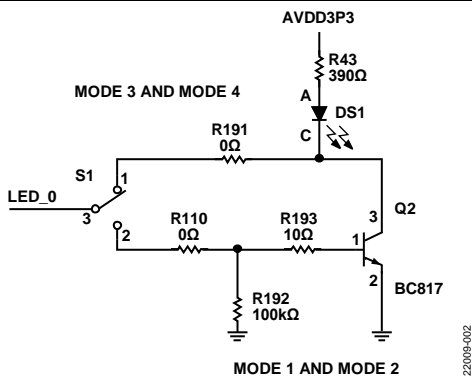

Figure 2. Hardware LED_0 Pin Configuration

MDIO INTERFACE

The MDIO interface dongle can be accessed directly through the P5 connector to connect the MDIO interface to the PHY.

The MDIO interface dongle also allows interfacing with the EVAL-ADIN1200FMCZ via the Ethernet PHY software GUI running on the PC (see Figure 3).

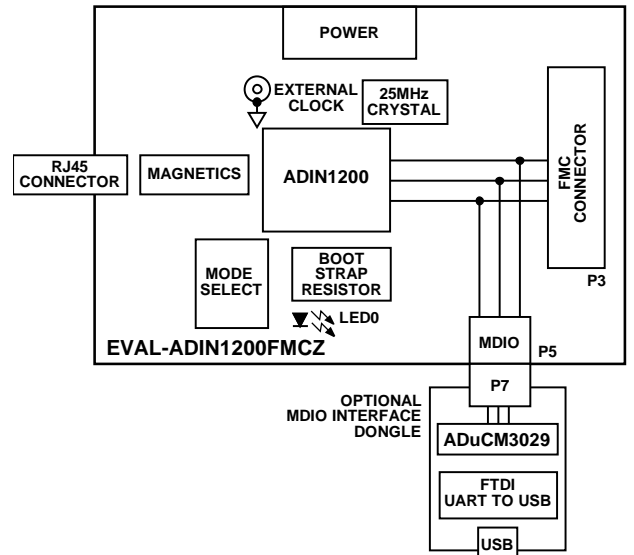

Figure 3. Simplified Overview of EVAL-ADIN1200FMCZ with MDIO Interface Dongle Connected

MDIO INTERFACE DONGLE

The MDIO interface dongle is a separate board included in the EVAL-ADIN1200FMCZ evaluation kit. The MDIO interface dongle has an on-board ADuCM3029 microcontroller and an FTDI Chip FT232RQ universal asynchronous receive transmitter (UART) to USB interface. The schematic for the MDIO interface dongle is shown in Figure 41. When using the MDIO interface dongle, connect the USB cable to the MDIO interface dongle first, then connect the MDIO interface dongle to the EVAL-ADIN1200FMCZ with the ADuCM3029 facing up (see Figure 4).

Using the MDIO interface dongle allows interaction with the ADIN1200 device via the Ethernet PHY software GUI running on the PC.

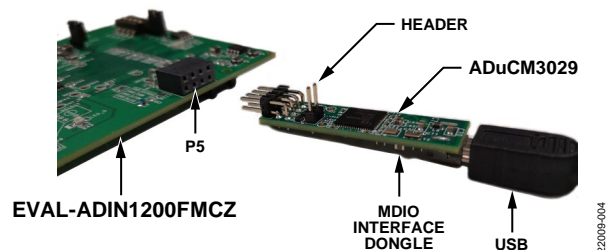

Figure 4. MDIO Interface Dongle Connection to the USB Cable and EVAL-ADIN1200FMCZ

There are two LEDs on the MDIO interface dongle, DS7 and DS8. When the powered USB cable is initially connected to the MDIO interface dongle, DS8 illuminates. When the Ethernet PHY software GUI establishes communication with the EVAL-ADIN1200FMCZ, DS7 and DS8 flash. The LEDs continue to flash while the GUI is active, and the EVAL-ADIN1200FMCZ is selected as the local board within the GUI.

The MDIO interface dongle has two push-button switches on the underside of the board, S5 and S6, as shown in Figure 5. S5 is for download and reboot purposes. S6 resets the on-board ADuCM3029.

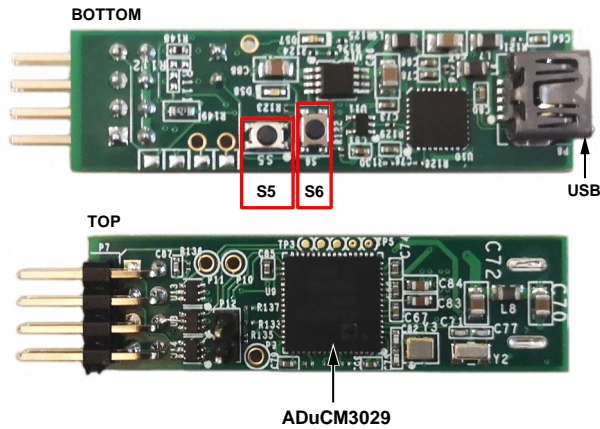

Figure 5. Overview of MDIO Interface Dongle

CONFIGURATION PINS SETUP

The EVAL-ADIN1200FMCZ default configuration and configuration options are detailed in Table 5. The ADIN1200 configuration settings can be changed by manipulating the resistors listed in the right column. See the ADIN1200 data sheet for more details on all available configuration options. Figure 7 shows the location of the resistors on the underside of the printed circuit board (PCB) of the EVAL-ADIN1200FMCZ. The speed configuration is configured via two rotary switches, S3 and S4, and the media defined interface configuration is controlled using the S9 switch. Table 5 lists the different switch configurations available.

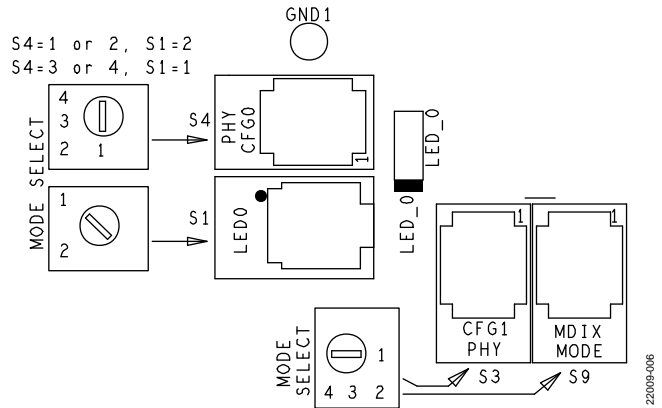

Figure 6. Mode Switch Configurations

Table 5. EVAL-ADIN1200FMCZ Configuration Settings

Configuration Options	Relevant Pins	Resistor and Switch Settings
PHY Address = 0b00000	RXD_3/PHYAD_3 RXD_2/PHYAD_2 RXD_1/PHYAD_1 RXD_0/PHYAD_0	R22, R29, R31, R37 = do not install R23, R30, R32, R38 = do not install Using internal pull-down resistors
MDIX Mode Configuration	GP_CLK/RX_ER/MDIX_MODE	S9 Position 1, Mode 1, manual MDI S9 Position 2, Mode 2, manual MDIX S9 Position 3, Mode 3, prefer MDIX S9 Position 4, Mode 4, prefer MDI (default)
PHY Configuration Downspeed, EDPD, Energy Efficient Ethernet (EEE), Software Power-Down, Forced Speed	LINK_ST/PHY_CFG1 LED_0/COL/TX_ER/PHY_CFG0	Controlled by S1, S3, and S4 switches to provide the various configuration options (see the ADIN1200 data sheet) Default configuration: S3 = 1 or 2 for the PHY_CFG1 function, note that the EVAL-ADIN1200FMCZ boards are shipped in pairs with one board set to 1 and the other set to 2 S4 = 4 for the PHY_CFG0 function, and S1 = 1 for the LED_0 function
MAC Interface Selection	RX_CTL/RX_DV/CRS_DV/MACIF_SEL1 RXC/RX_CLK/MACIF_SELO	R8, R9 = do not install R27, R28 = do not install Using internal pull-down resistors results in MAC interface default selection being the reduced gigabit media independent interface (RGMII) MAC interface with 2 ns internal delay on the RXC signal and TXC signal

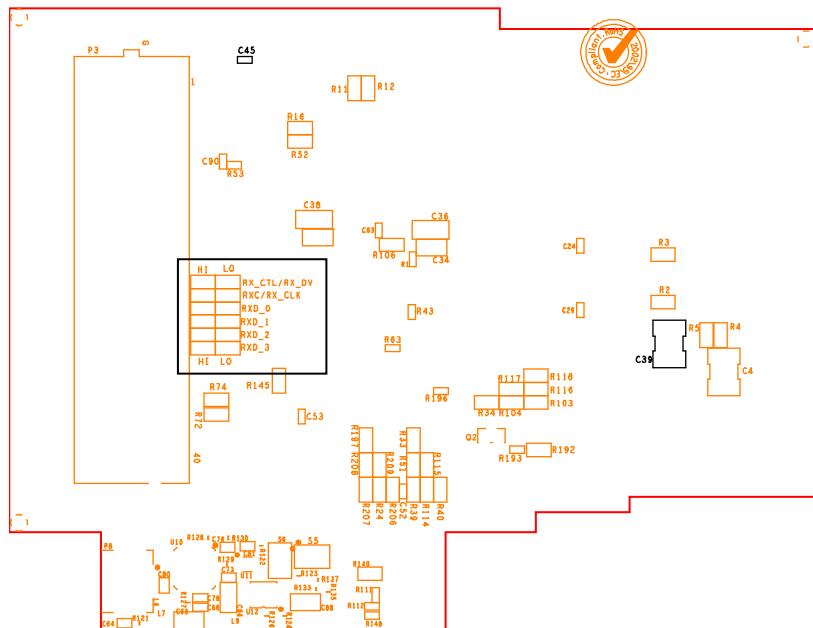

Figure 7. Configuration Resistor Placement, Underside of PCB

22005-007

SOFTWARE OVERVIEW

INSTALLING THE ETHERNET PHY SOFTWARE

The Ethernet PHY software GUI requires the installation of the Ethernet PHY software and the installation of the USB communications drivers. Both installations must be complete before connecting the EVAL-ADIN1200FMCZ to the USB port of the PC to ensure that the evaluation system is correctly recognized when connected to the PC.

First, install the Ethernet PHY software and the [ADIN1200](#) data sheet and the EVAL-ADIN1200FMCZ user guide. The installation steps are listed in the Ethernet PHY Software GUI Installation section. The default location for the Ethernet PHY software GUI installation is the C:\Analog Devices folder.

When the Ethernet PHY software installation is complete, install the USB communications drivers. The MDIO interface dongle uses the FT232RQ for UART to USB communication. The MDIO interface dongle requires the installation of drivers for the FTDI Chip USB UART IC. Locate and install this driver separately. These drivers are available at the FTDI website.

Ethernet PHY Software GUI Installation

To install the Ethernet PHY software GUI, take the following steps:

1. Launch the installer file to begin the Ethernet PHY software installation.
2. If a window appears asking for permission to allow the program to make changes to the PC, click **Yes**.
3. The welcome window appears (see Figure 8). Click **Next**.



Figure 8. Welcome Window

22009-008

4. The Ethernet PHY software launches. An overview of the software being installed and recommendations in terms of hardware power-up appears. Read the overview and click **Next** (see Figure 9).

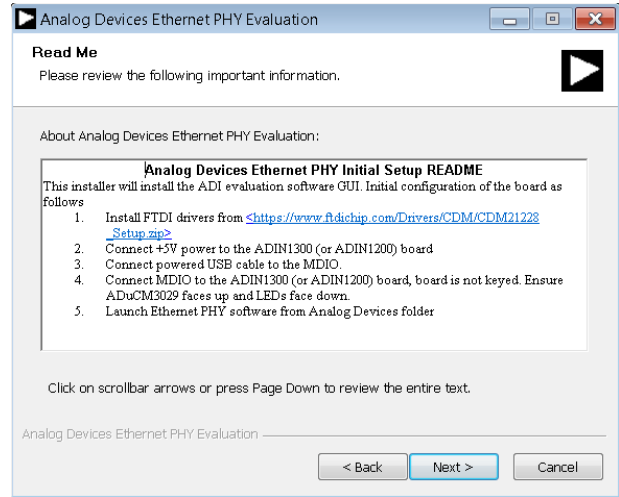

Figure 9. Installation Process Overview

22009-009

5. A license agreement appears. Read the agreement and click **I Agree** to allow the installation to proceed (see Figure 10).

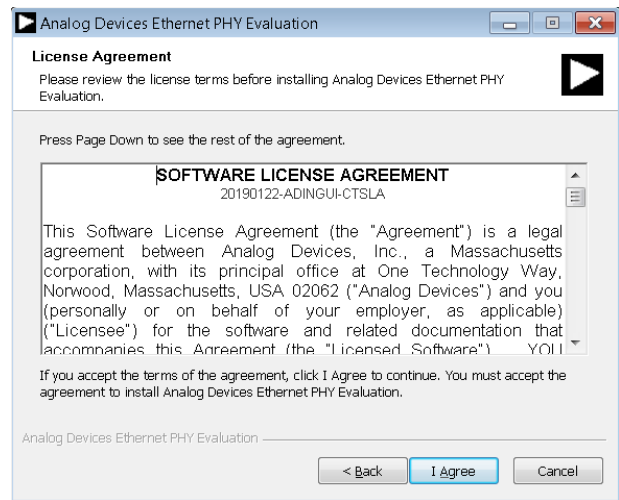

Figure 10. Accepting the License Agreement

22009-010

6. Select a location to install the Ethernet PHY software and then click **Install** (see Figure 11).

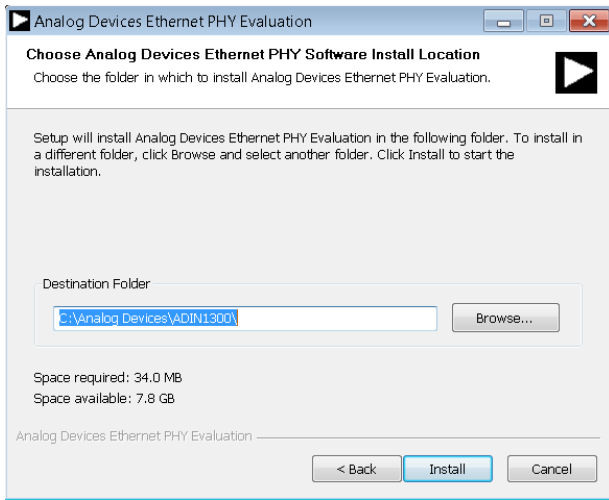

Figure 11. Installation Location

7. A window appears stating that the installation is complete. Click **Finish** to continue (see Figure 12).

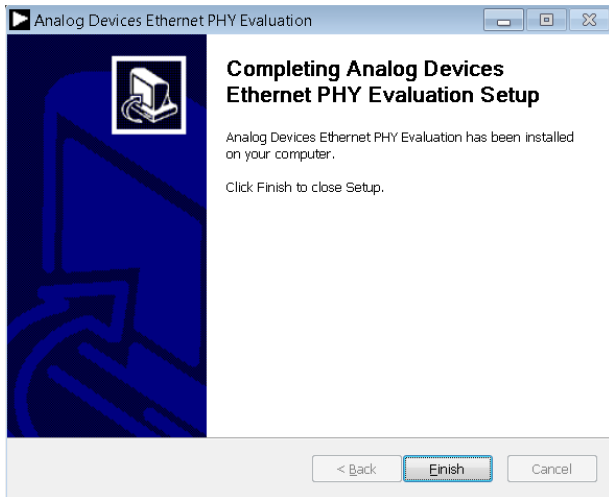

Figure 12. Installation Complete

8. The Ethernet PHY software is automatically installed in the **Analog Devices** folder on the PC. The default folder name is **ADIN1300** as the software GUI also supports the **ADIN1300**. Access the Ethernet PHY software via Windows® explorer at **C:\Analog Devices\ADIN1300** or from the **Start** menu. When the software loads, it reads the device MODEL_NUM to determine what device is connected and configure the software GUI accordingly (**ADIN1200** or **ADIN1300**).

INITIAL SETUP

To set up the EVAL-ADIN1200FMCZ and use it with the Ethernet PHY software GUI, take the following steps:

1. Connect a 5 V power supply to the EVAL-ADIN1200FMCZ via the EXT_5V connector or the 5 V barrel connector.
2. Connect the USB cable to the MDIO interface dongle.
3. Connect the USB cable to the PC. When connecting the EVAL-ADIN1200FMCZ to the PC for the first time, the drivers are automatically installed. Wait until the driver installation is complete before proceeding to the next step.
4. Ensure that the **ADuCM3029** microcontroller faces up (see Figure 4) and connect the MDIO interface dongle to the EVAL-ADIN1200FMCZ. The MDIO interface dongle is not keyed.
5. Launch the Ethernet PHY software from the **Analog Devices** folder in the **Start** menu.

USING THE EVALUATION SOFTWARE

When the Ethernet PHY software is launched, the GUI window shown in Figure 13 appears. Figure 13 shows the GUI features with labels, and Table 6 lists the GUI labels and the corresponding descriptions.

Table 6. GUI Label Descriptions

Label	Description
1	Select Local section. Shows connected evaluation hardware. The board name shown corresponds to the MDIO interface dongle that is connected to the EVAL-ADIN1200FMCZ.
2	User buttons.
3	Link Properties tab. Use this tab to change the PHY configuration.
4	Register Access tab. Allows the user read or write device registers.
5	Clock Pin Control tab. Controls which clock is applied to the GP_CLK/RX_ER/MDIX_MODE pin.
6	Loopback tab. Controls the various loopback modes.
7	Test Modes tab. Provides access to the various test modes on the device.
8	FrameGenerator/Checker tab. Configures and enables the frame generator and frame checker.
9	Cable Diagnostics tab. Provides easy access to the cable diagnostics features on the device.
10	Activity information window. This window provides an overview of the PHY activity, reads, and writes issued to the device.
11	Activity Log. Window showing read, write, and status activity for the selected PHY.
12	Dropdown menus to load a script file. These two dropdown menus allow the user to load a script file with a sequence of write commands to load to the device.

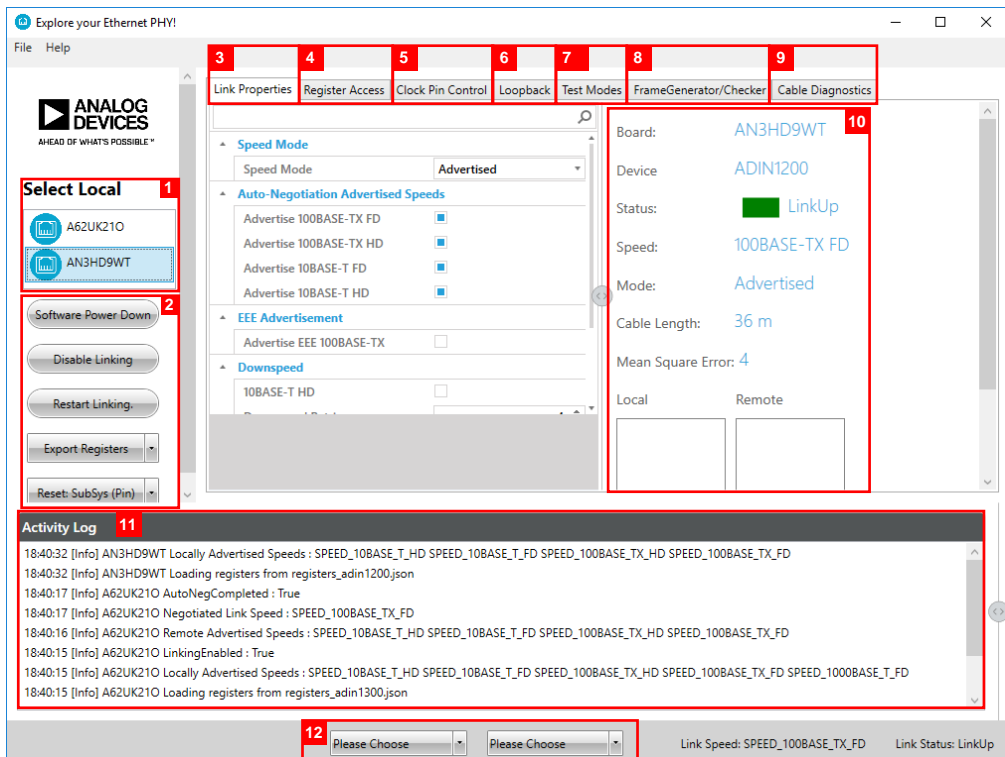

Figure 13. Main GUI Window

BOARD DISPLAY SHOWING CONNECTED EVAL-ADIN1200FMCZ HARDWARE

In the **Select Local** section (see Figure 13), a unique hardware identifier is shown for each MDIO interface dongle connected to the PC. In the example shown in Figure 14, there are two MDIO interface dongles connected to the same PC (the A62UK210 and AN3HD9WT).

The Ethernet PHY software GUI can only communicate with one MDIO interface dongle at a time. To choose which MDIO interface dongle is addressed as the local board in this section, click the appropriate device identifier to select and highlight it. All register controls, displayed link properties, and local board information in other sections of the GUI apply to the selected **ADIN1200** device connected to the MDIO interface dongle.

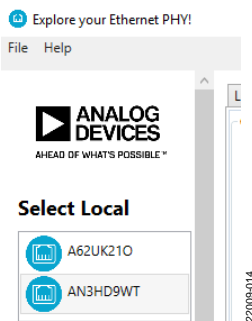

Figure 14. MDIO Interface Dongle Selection

USER BUTTONS SECTION

Use the buttons in this section to control the basic operation of the GUI and the **ADIN1200** device.

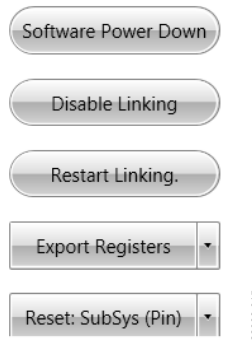

Figure 15. Basic User Buttons

Software Power-Down and Power-Up

Click **Software Power Down** to place the selected device into software power-down mode where the analog and digital circuits are placed into a low power state. Most clocks are gated off and no link is brought up. Click **Software Power Down** to enable a software power-down. The button color changes to orange and the button text changes to **Software Power Up**. Click **Software Power Up** to exit from the software power-down and restart linking. When the software power-down is asserted, the other buttons for the selected device are grey and disabled.

Disable or Enable Linking

Click **Disable Linking** to disable linking when a link is up. The button changes from **Disable Linking** to **Enable Linking**. Click **Enable Linking** to enable linking.

Restart Linking

If the software configuration has been changed, click **Restart Linking** to restart the linking process with the new configuration. If the link is already established, the link is first brought down and then restarted.

Export Registers

Click **Export Registers** to perform a data dump to the **Activity Log** section. The register dump can be saved to text format for offline review. Right click and click **Save as** to save the data to a log file.

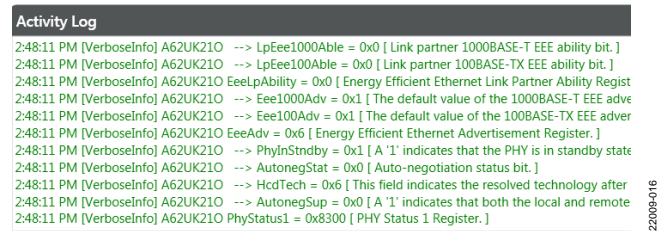

Figure 16. Activity Log with Export Registers Displayed

Reset

Click **Reset** to use the dropdown menu to initiate different resets. The reset options include the following:

- Subsystem software reset with pin configuration: click **Reset: SubSys (Pin)** to perform a reset of the subsystem with the subsystem requesting a new set of hardware configuration pin settings from the chip during the software reset sequence. The GE_SFT_RST bit and the GE_SFT_RST_CFG_EN bit are set to 1.
- Subsystem software reset: click **Reset: SubSys** to perform a reset of the subsystem with the subsystem requesting previously stored hardware configuration pin settings to be reloaded during the software reset sequence. The GE_SFT_RST bit and the GE_SFT_RST_CFG_EN bit are set to 0.
- PHY core software reset: click **Reset: PHY** to perform a reset where the SFT_RST bit resets the PHY core registers.

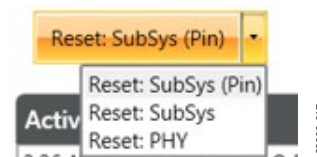

Figure 17. Reset Options

LINK PROPERTIES TAB

The **Link Properties** tab provides the user access to the main linking configurations within the device. This tab has a slider to access all controls. When a control is selected, the GUI provides

a prompt describing the function at the bottom of the linking control box (see Figure 18).

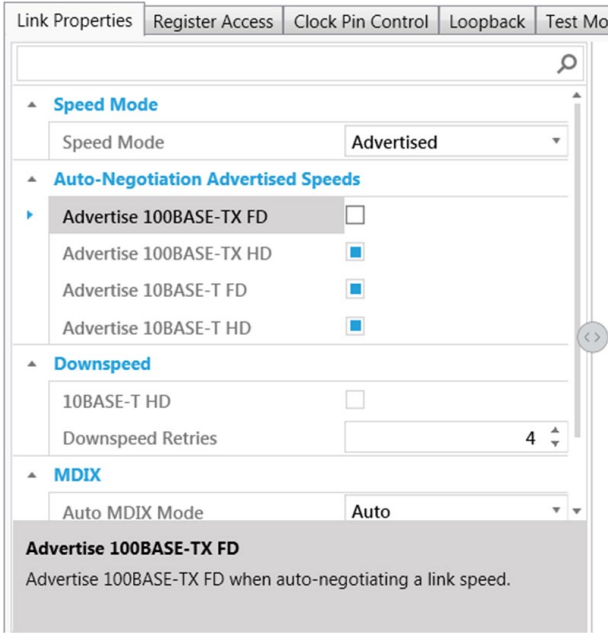

Figure 18. Link Properties Tab

Speed Mode

For the selected device, advertised speed or forced speed can be chosen. The speed selection prepopulates the remaining user controls for the **Link Properties** tab with the following:

- **Advertised:** subset of controls available in advertised mode. The controls include the following:
 - **Auto-Negotiation Advertised Speeds:** shows the checkbox availability of all autonegotiated advertised speeds available. Select and clear the checkboxes as required. All speed options are available in this section. The default advertised reflects the hardware configuration pins.
 - **EEE Advertisement:** use the checkboxes to advertise the EEE as a speed option for 1000BASE-T and 100BASE-TX.
 - **Downspeed:** use the checkbox to enable downspeed, which allows the PHY to change to a lower speed after a number of attempts to bring up a link at the highest advertised speed.
 - **Downspeed Retries:** sets the number of times the PHY attempts to bring up a link. The default is four attempts.
 - **MDIX:** use the dropdown menu to choose **Auto MDIX**, **FixedMDI**, or **FixedMDIX** (**FixedMDI** and **FixedMDIX** not shown in Figure 18).
 - **Energy Detect PowerDown Mode:** use the dropdown menu to choose **Disabled**, **Enabled**, or **EnabledWithPeriodicPulseTx**.

- **Forced:** subset of controls available in forced mode. The controls include the following:
 - **Forced Speeds:** use the dropdown menu to choose the required speed.
 - **MDIX:** use the dropdown menu to choose **Auto**, **FixedMDI**, or **FixedMDIX**.
 - **Energy Detect Powerdown Mode:** use the dropdown menu to choose **Disabled**, **Enabled**, or **EnabledWithPeriodicPulseTx**.

REGISTER ACCESS TAB

The **Browse** tab within the **Register Access** tab allows the user to review the bank of registers and edit the register fields or bit fields as required (see Figure 19).

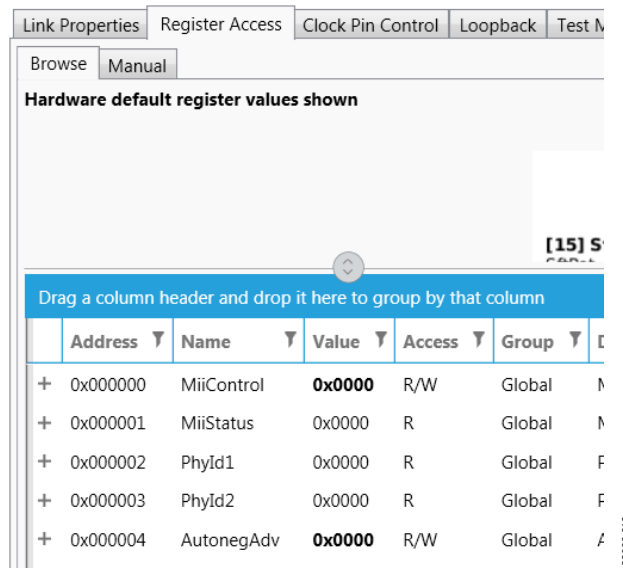

Figure 19. Register Access Tab Full Register Map

The **Manual** tab within the **Register Access** tab allows the user to perform basic reads from and writes to individual **ADIN1200** registers (see Figure 20).

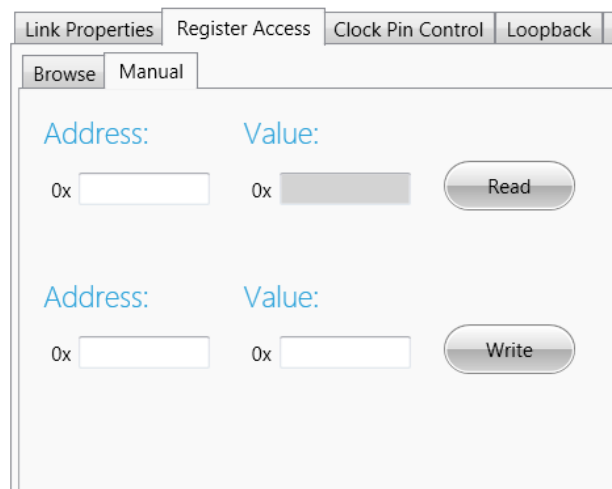

Figure 20. Register Access Tab

Access the direct register read/write function on the right side of the **Activity Log** section. To access this function, slide the arrow to the left to expose it (see Figure 21).

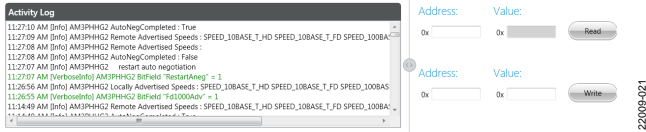

Figure 21. Activity Log Section Register Access

CLOCK PIN CONTROL TAB

Use this tab to control which clock is applied to the GP_CLK/RX_ER/MDIX_MODE pin (see Figure 22).

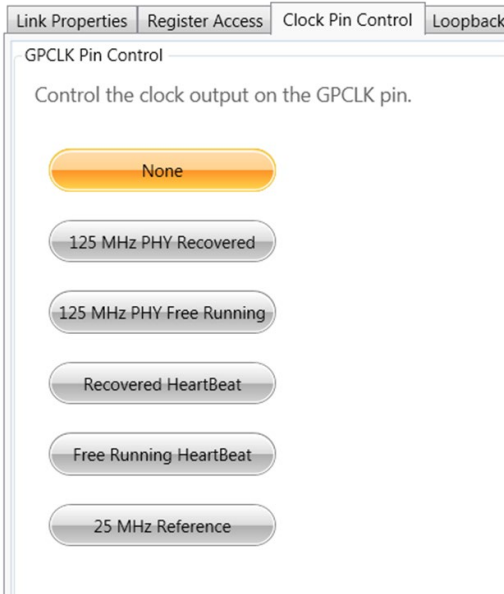

Figure 22. Clock Pin Control Tab

LOOPBACK TAB

The various loopback modes are available in this tab (see Figure 23). Consult the ADIN1200 data sheet for a full description of each loopback mode.

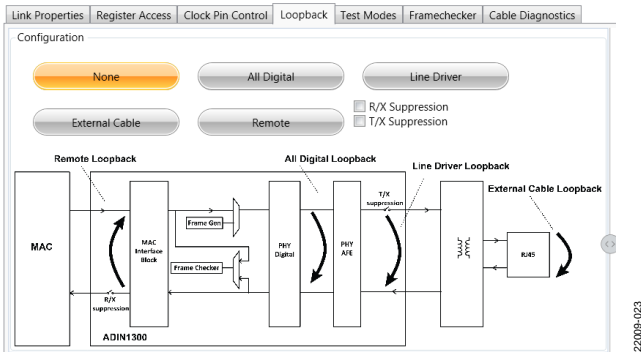

Figure 23. Loopback Tab

TEST MODES TAB

Use this tab to initiate the various test mode functions in the device. Select the appropriate test mode and click **Execute Test** (see Figure 24).

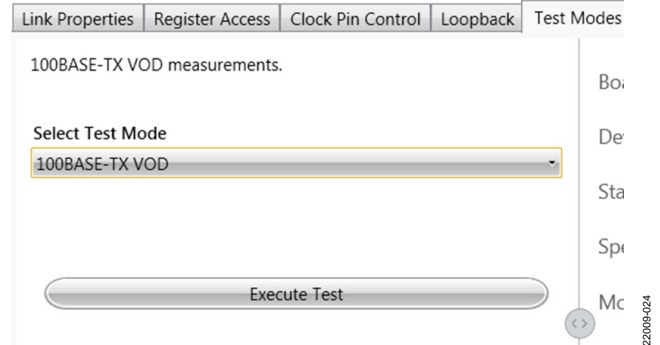

Figure 24. Test Modes Tab

FRAMEGENERATOR/CHECKER

This tab provides access to the frame generator and frame checker features of the ADIN1200 (see Figure 25).

Control the number of frames generated by the generator, the frame length, and the content of the frame within this tab. Choose to have the frame generator to either run in burst mode or run continuously. To halt the frame generator when the frame generator is running continuously, use the **Terminate** button.

Use the **Remote** button to enable the remote device to loop back the data to the local device. To ensure that the appropriate device is selected, choose which connected board is the local, configure that board to generate frames, then configure the other board in remote loopback.

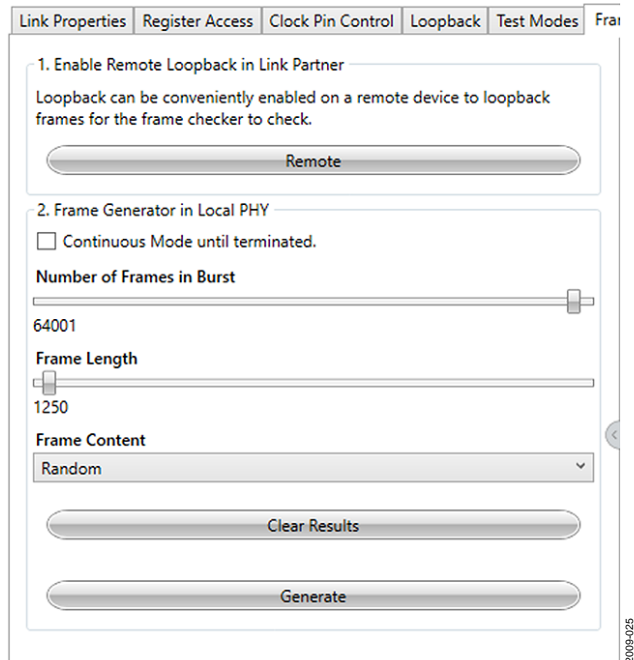

Figure 25. Overview of Frame Generator and Frame Checker

The frame checker information displayed on the screen accumulates the number of frames sent and shows the number of errors observed (see Figure 26).

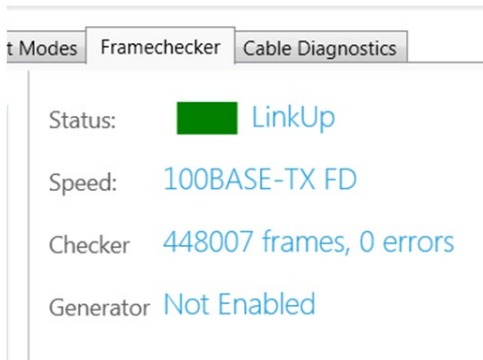

Figure 26. Frame Generator Status and Frame Checker Result

CABLE DIAGNOSTICS TAB

The cable diagnostic feature allows the user to diagnose issues with the link. Various features within the device are available when the link is established, which measure the quality of the link using features such as the mean squared error (MSE) level and estimated cable length. These measurements are displayed in the main **Link Properties** tab.

The features in the **Cable Diagnostics** tab, see Figure 27, are available to run when the link is disabled, such as checking for short circuits, checking for open circuits, and identifying the distance to the first fault (see Figure 29). The LINK_EN bit must be clear to run these checks.

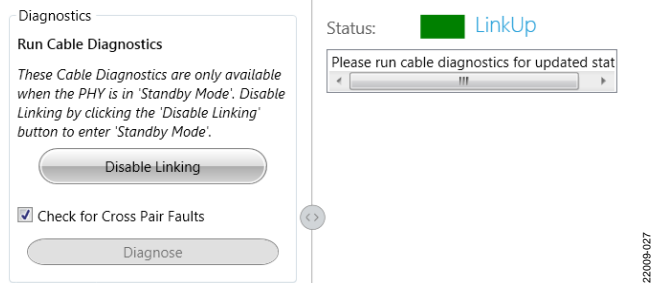

Figure 27. Cable Diagnostics Configuration with Link Up

Click the **Disable Linking** button to set the LINK_EN bit to 0 to allow diagnostics to be run (see Figure 28 through Figure 30).

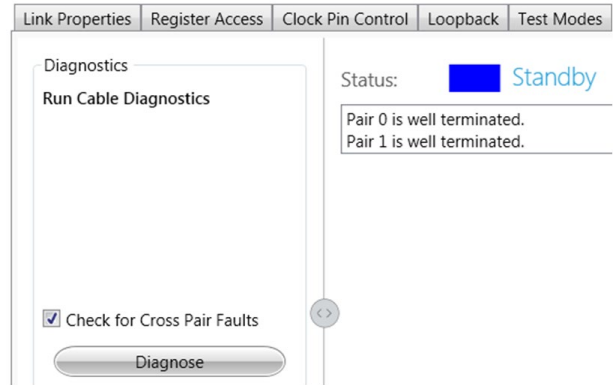

Figure 28. Cable Diagnostics Configuration When Link Is Disabled with Cable Connected to Remote PHY

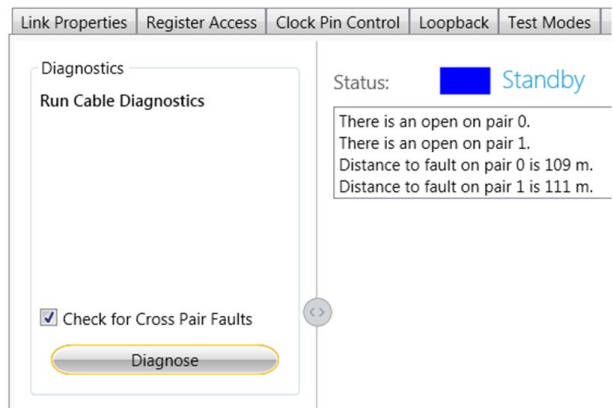

Figure 29. Cable Diagnostics Configuration with Cable Open

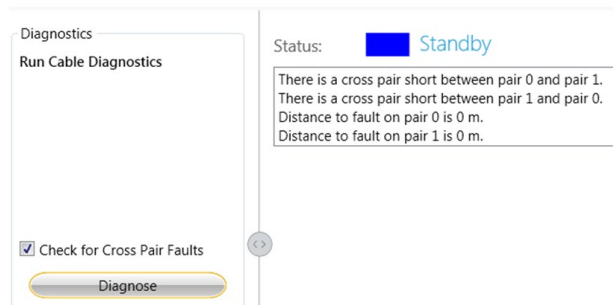

Figure 30. Cable Diagnostics Configuration with Cable Crossed

ACTIVITY INFORMATION WINDOW AND LINKING STATUS

This window displays the current status of the selected PHY chip (as determined in the **Select Local** section) including whether a link is established, the speed of the link, and the speed mode. The **Local** and **Remote** sections show the advertised speeds available in the local PHY device and the advertised speeds available that the remote PHY is returning (see Figure 31).

If the user switches between two evaluation boards in the **Select Local** section, the information shown in these fields updates to reflect the information provided from the board defined as local.

Board: AM3XHNWZ
 Device: ADIN1200
 Status: █ LinkUp
 Speed: 100BASE-TX FD
 Mode: Advertised
 Cable Length: 115 m
 Mean Square Error: 2

Local	Remote
100BASE-TX FD	100BASE-TX FD
100BASE-TX HD	100BASE-TX HD
10BASE-T FD	10BASE-T FD
10BASE-T HD	10BASE-T HD

Figure 31. Linking Status

The GUI displays a color code to show the status of the link depending on how the user has configured the device (see Figure 32).

Status: █ Powerdown
 Status: █ Standby
 Status: █ LinkDown
 Status: █ LinkUp

Figure 32. GUI Link Status

ACTIVITY LOG INFORMATION SECTION

The activity log reports status information and register write issues to the selected evaluation board (see Figure 33). The activity log captures the activity in the GUI corresponding to the activity on the local PHY, which indicates the various reads, writes, and information on whether a link is established. When

the frame generator is enabled, this window shows the frame generator activity. The board identification is recorded with each bit field change to clarify which device is being addressed.

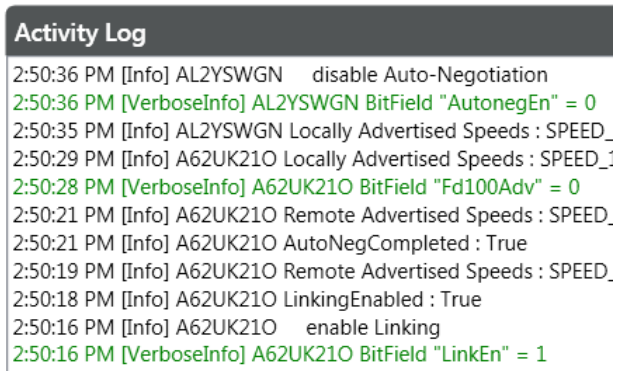

Figure 33. Activity Log Showing Device Status

To clear the activity log, right click and then click **Clear**. To export the contents of the activity log for offline review, right click and then click **Save as**. The file saved is a text file with a default location in the **Analog Devices > ADIN1200** folder.

LOADING A SCRIPT FILE

The GUI allows the user to load a sequence of register commands from a file. Within the GUI window, there are two dropdown menus under the **Activity Log** section where the user can select the script file and the section of the script to run. Click a dropdown menu, choose the script by name, and then click the same dropdown menu again to load the selected script. The activity log displays the register writes issued from the script.

```

Advertised Speeds : SPEED_10BASE_T_HD SPEED_10BASE_T_FD SPEED_100BASE_TX_HD
dvertised Speeds : SPEED_10BASE_T_HD SPEED_10BASE_T_FD SPEED_100BASE_TX_HD :
gCompleted : True
ted Link Speed : SPEED_1000BASE_T_FD
rcvrOk : True
rrOk : True
e : AM3PHHG2
s are present : AM3PHHG2 AN3Y4T18
    
```



Figure 34. Script File Loading Dropdown Menus

The script file is located in the **ADIN1300** folder by default as the software GUI also supports the **ADIN1300** device and is named **registers_scripts.json** (see Figure 35).

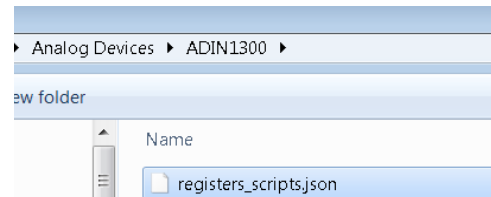

Figure 35. Script File Location

The register commands can be loaded with either the register name or the register address, as shown in the simple examples in the file. The commands are loaded sequentially. Create the sequence of write commands using a text editor. Ensure that the exact syntax is copied and match the register names with those in the data sheet to prevent errors reported in the activity log. Give the script a unique name. When the **SftPd Down&Up** routine is selected, see the following example:

```
{
  Name: SftPd Down&Up,
  RegisterAccesses: [
    {
      MemoryMap : GEPHY,
      RegisterName: SftPd,
      Value: 1
    },
    {
      MemoryMap : GEPHY,
      RegisterName: SftPd,
      Value: 0
    },
  ]
},
```

TROUBLESHOOTING

SOFTWARE INSTALLATION TIPS

Ethernet PHY software installation tips follow:

- Always allow the software installation to be completed, and keep in mind that the Ethernet PHY software is a two-part installation including the Analog Devices, Inc., package installer (GUI, ADIN1200 data sheet, and EVAL-ADIN1200FMCZ user guide) and the FTDI drivers which can be found at the FTDI website. The installation may require a restart of the PC.
- When the MDIO interface dongle is first plugged in via the USB cable, allow the found new hardware wizard to run completely. This step is required prior to starting the Ethernet PHY software.
- If the EVAL-ADIN1200FMCZ does not appear in the GUI window, ensure that the following steps have been completed:
 - Power is applied to the EVAL-ADIN1200FMCZ.
 - The powered USB connector is connected to the MDIO interface dongle.
 - Both the EVAL-ADIN1200FMCZ and the MDIO interface dongle are connected together.
 - The Ethernet cable is connected.
 - The Ethernet PHY software is launched.

SOFTWARE TIPS

If the Ethernet PHY software does not read any data back, check for any messages in the **Activity Log** section. There is one known communication bug in the connection of the MDIO interface dongle and EVAL-ADIN1200FMCZ, as discussed in the MDIO Interface Dongle Communications Known Issue section.

MDIO Interface Dongle Communications Known Issue

A known behavior when using the MDIO interface dongle with the EVAL-ADIN1200FMCZ is related to the sequence of how the boards are powered and connected together. If the GUI is open, and the user connects the MDIO interface dongle to the EVAL-ADIN1200FMCZ before connecting the USB power to the MDIO interface dongle, the GUI may not properly establish communications with the MDIO interface dongle.

The GUI polls for the MDIO interface dongle regularly, and if an error in the MDIO interface dongle communications is

found, it is flagged in the **Activity Log** section and highlighted in red font, as shown in Figure 36. The message also includes a prompt explaining how to resolve the issue.

In the example shown in Figure 36, the user is advised to reset the MDIO interface dongle via Button S6. There are two buttons on the underside of the MDIO interface dongle. In this case, the user must identify S6 and reset. This action restarts the MDIO interface dongle. If the S6 restart does not resolve communications, exit the GUI and relaunch the Ethernet PHY software.

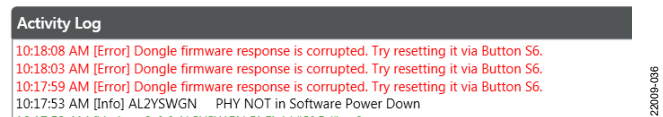

Figure 36. Example **Activity Log** when MDIO Interface Dongle is Not Responding

HARDWARE TIPS

Ensure that power is applied to the MDIO interface dongle and EVAL-ADIN1200FMCZ as previously discussed in the Power Sequencing section. Measure the voltage at various points on the EVAL-ADIN1200FMCZ using the AVDD_3P3 and VDDIO test points. Crosscheck the voltages against the information in Table 1.

No Link Established

If no link is established, use the following steps to assist debug:

- Ensure that the Ethernet cable is connected properly to the registered Jack 45 (RJ45) connector and between the evaluation boards or PHY pairs.
- When using two EVAL-ADIN1200FMCZs, ensure that both boards are powered.
- Ensure that the hardware configuration is appropriate for the required linking arrangement.

LED Not Illuminated, But Link Established Reported in GUI

By default, LED_0 illuminates when a link is established, and flashes when there is activity. The EVAL-ADIN1200FMCZ is configured for Mode 3 and Mode 4 by default, with S1 in Position 1. If PHY_CFG0 is to be used in Mode 1 or Mode 2, change the position of S1 from 1 to 2, as described in Table 4.

LAYOUT GUIDELINES

BOARD STACKUP

The EVAL-ADIN1200FMCZ consists of a 4-layer PCB. The layers include the top layer, Layer 2, Layer 3, and the bottom layer. All layers have a copper pour, with an exception around sensitive traces for the MAC and MDI interfaces.

GROUND PLANES

The top and bottom layers of the EVAL-ADIN1200FMCZ mainly carry signal and routing signals from the [ADIN1200](#). The two inner layers are used for ground planes. Layer 2 is a full ground plane. Layer 3 consists primarily of ground with area dedicated to the AVDD_3P3 and VDDIO power planes. Although the [ADIN1200](#) is a mixed-signal device, it only has one type of ground return, GND.

ISOLATION GUIDELINES

Transformer Layout

No metal layers can be directly underneath the transformer to minimize any noise coupling across the transformer.

RJ45 Layout

For optimal electromagnetic computability (EMC) performance, use a metal, shielded, RJ45 connector with the shield connected to chassis ground. There must be an isolation gap between the chassis ground and the IC GND with consistent isolation across all layers.

POWER SUPPLY DECOUPLING

From a PCB layout point of view, it is important to locate the decoupling capacitors as close as possible to the power supply and GND pins to minimize the inductance.

MAC INTERFACE

When routing the MAC interface traces, ensure that the lengths of the pairs are matched. Avoid crossover of the signals where possible. Stubs must be avoided on all signal traces. It is recommended to route traces on the same layer.

MANAGEMENT INTERFACE

MDI Interface

Traces running from the MDI_x_P or MDI_x_N pins of the [ADIN1200](#) to the magnetics must be on the same side of the EVAL-ADIN1200FMCZ (no vias), kept as short as possible (less than 1 inch in length), and individual trace impedance of these tracks must be kept below 50 Ω with a differential impedance of 100 Ω for each pair. The same recommendations apply for traces running from the magnetics to the RJ45 connector.

Impedance must be kept constant throughout. Any discontinuities may impact signal integrity.

Each pair must be routed together with the same trace widths throughout. Trace lengths must be kept equal where possible and any right angles on these traces must be avoided (use curves or 45° angles in the traces). Stubs must be avoided on all signal traces. It is recommended to route traces on the same layer.

PLACEMENT OF THE TVS DIODE

It is recommended to place the TVS diode close to the [ADIN1200](#) device to ensure minimal track inductance between the external protection and internal protection within the device.

THERMAL CONSIDERATIONS

The [ADIN1200](#) is packaged in an LFCSP package. This package is designed with an exposed pad that must be soldered to the PCB for mechanical and thermal reasons. The exposed paddle acts to conduct heat away from the package and into the PCB. By incorporating an array of thermal vias in the PCB thermal paddle, heat is dissipated more effectively into the inner metal layers of the PCB. When designing the PCB layout for optimum thermal performance, use a 4 × 4 array of vias under the exposed pad.

This LFCSP device includes two exposed power bars adjacent to the exposed pad at the top and bottom. These power bars are connected to internal power rails and the area around them is a keep out zone. Keep these areas clear of traces or vias.

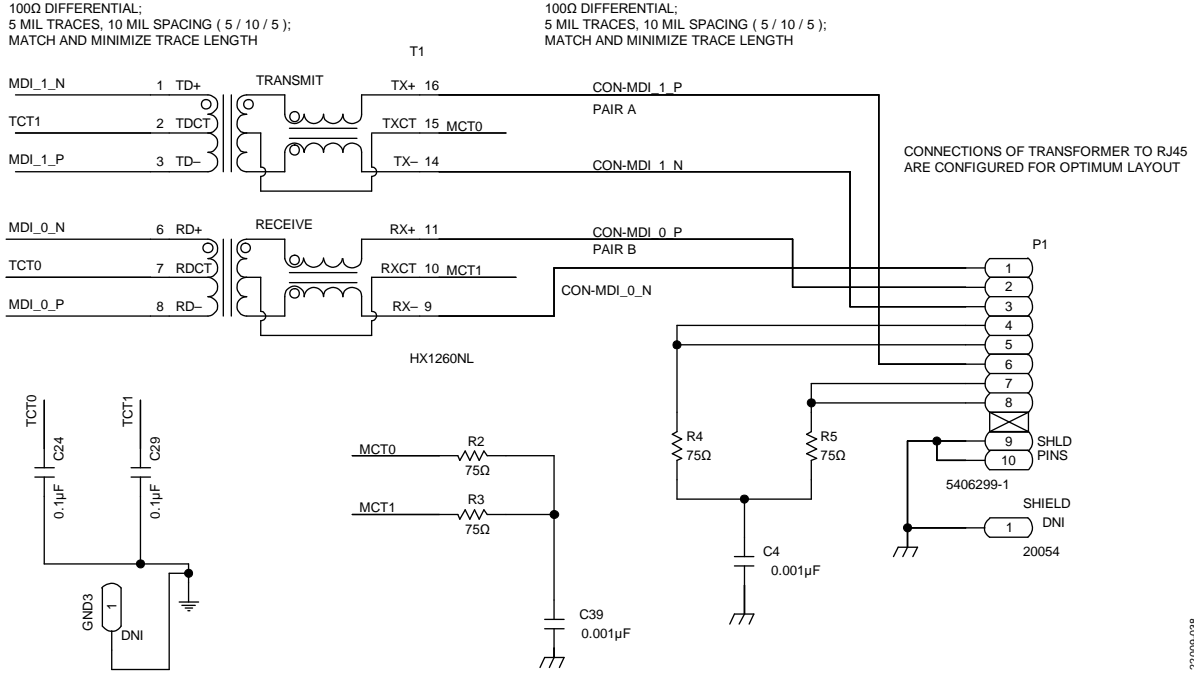

Figure 38. Magnetics

PLACEHOLDERS FOR ADDITIONAL DECOUPLING
ALONG THE SUPPLY TRACE

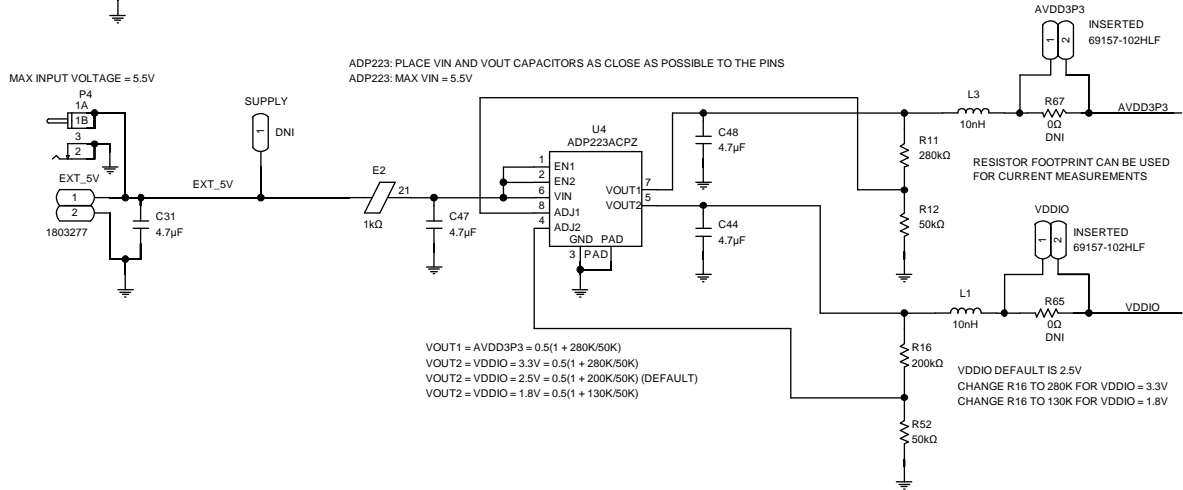
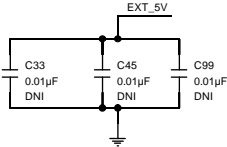
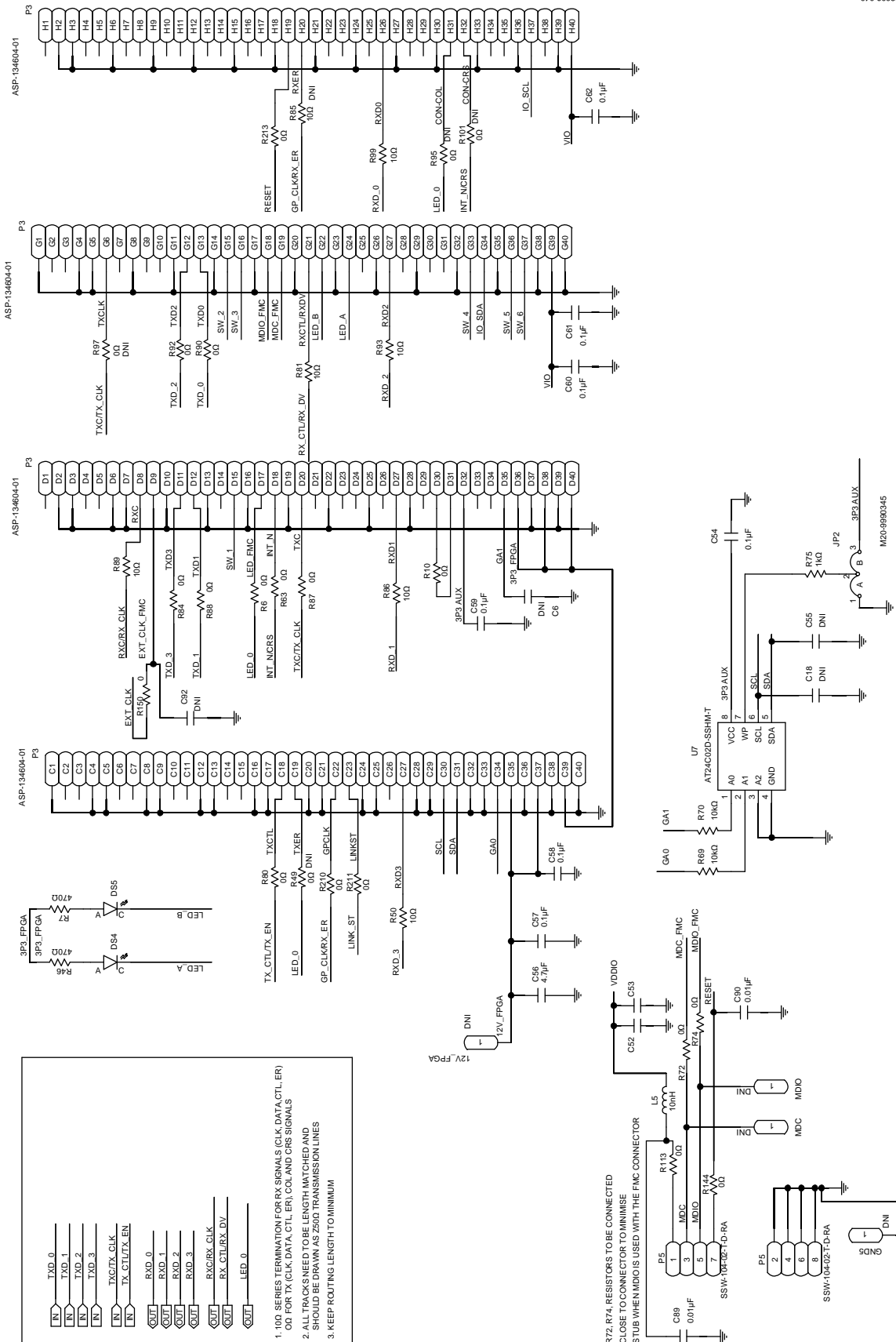

Figure 39. Power Supplies

2209-040



- 1. 100 OHM SERIES TERMINATION FOR RX SIGNALS (CLK, DATA, CTL, ER) FOR TX (CLK, DATA, CTL, ER), COL AND CRS SIGNALS
- 2. ALL TRACKS NEED TO BE LENGTH MATCHED AND SHOULD BE DRAWN AS Z500 TRANSMISSION LINES
- 3. KEEP ROUTING LENGTH TO MINIMUM

R72, R74, RESISTORS TO BE CONNECTED CLOSE TO CONNECTOR TO MINIMIZE STUB WHEN MDIO IS USED WITH THE FMC CONNECTOR

Figure 40. FMC Connector

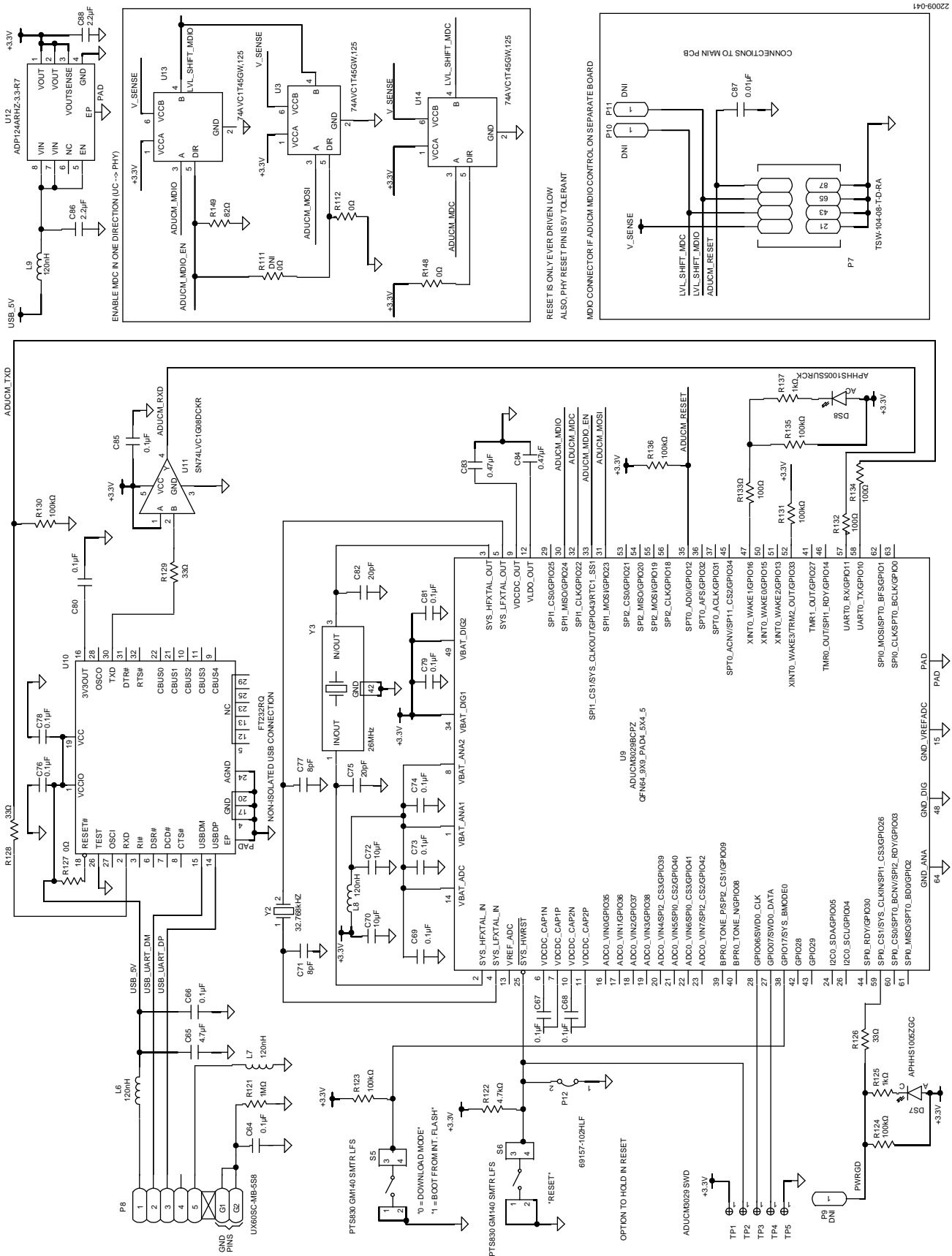
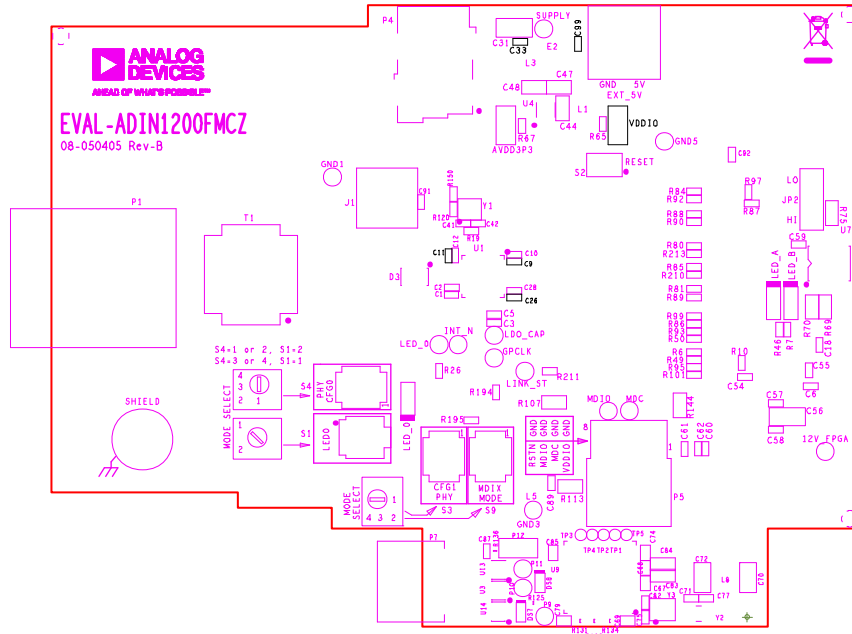
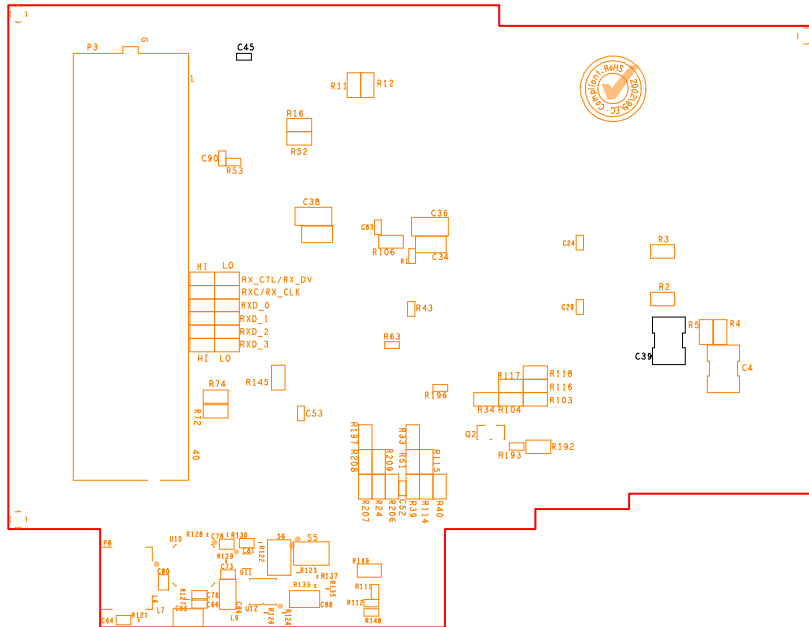

Figure 41. MDIO Interface Dongle



22009-042

Figure 42. Schematic Silkscreen, Top



22009-043

Figure 43. Schematic Silkscreen, Bottom

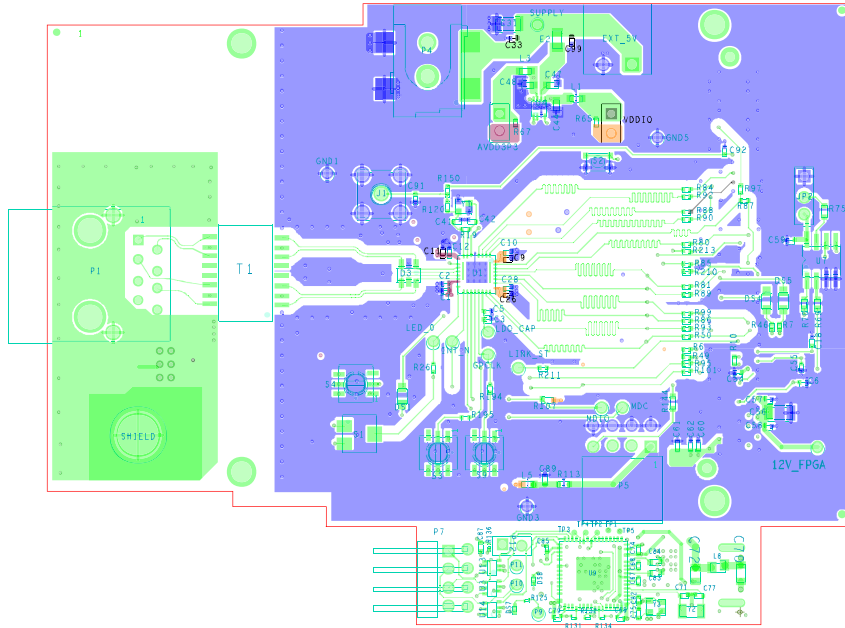

Figure 44. Top Layer

22009-044

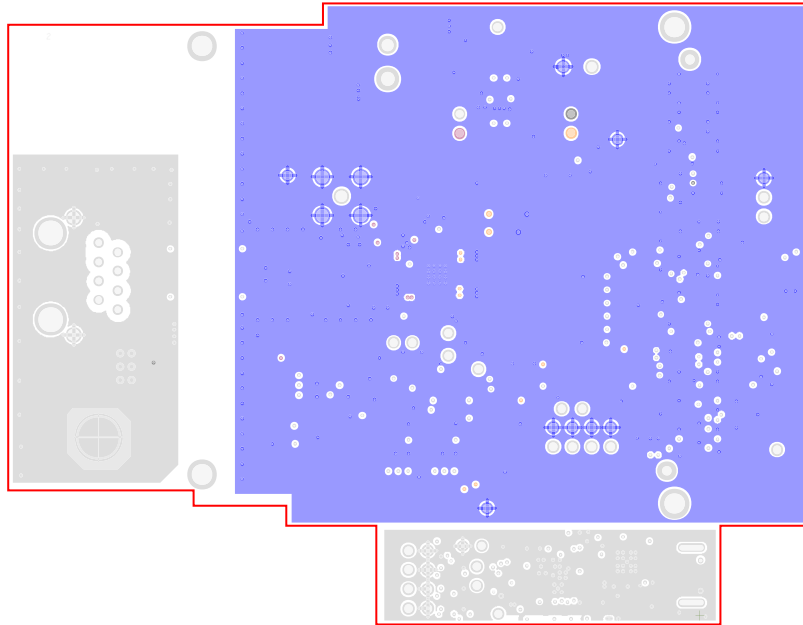
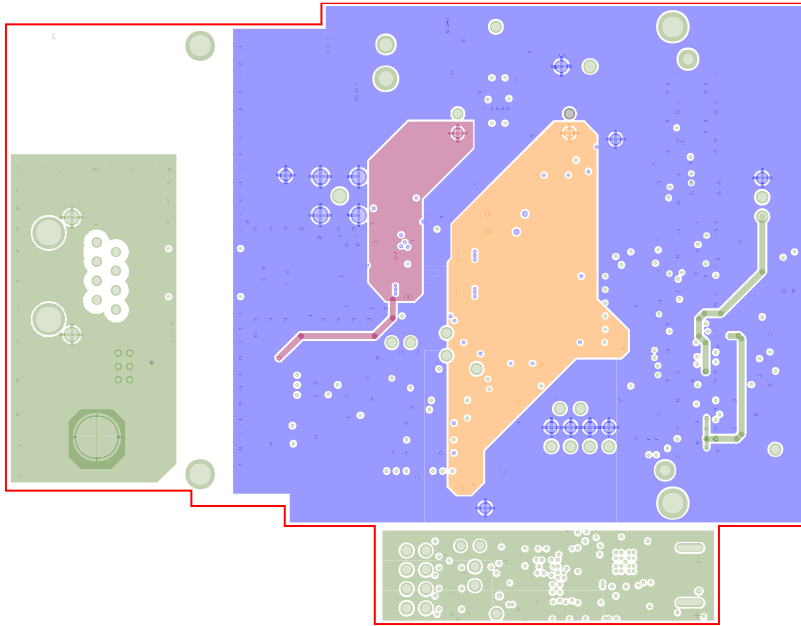

Figure 45. Layer 2, Ground Layer

22009-145



22009-045

Figure 46. Layer 3, Power and Ground Layer

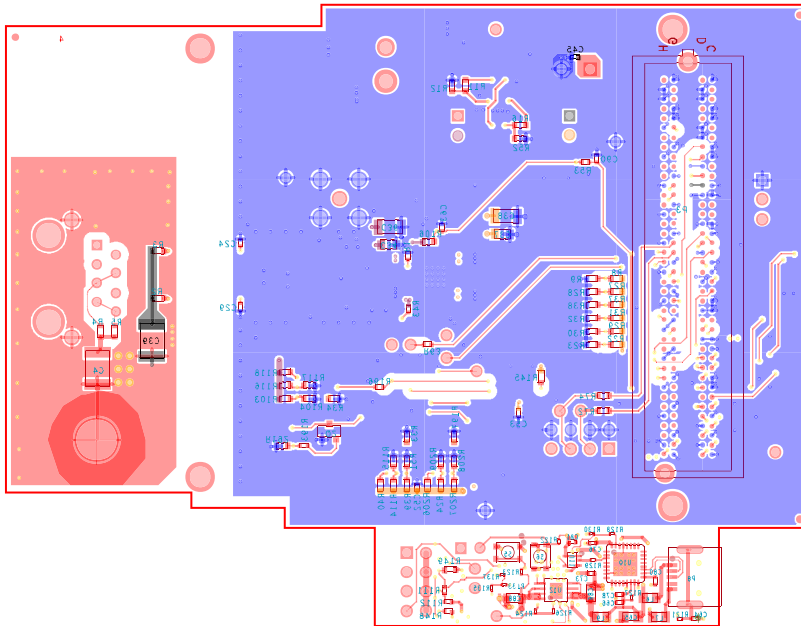

22009-046

Figure 47. Layer 4, Bottom Layer

ORDERING INFORMATION

BILL OF MATERIALS

Table 7.

Qty	Reference Designator	Description	Supplier	Device Number
3	AVDD3P3, P12, VDDIO	Connector, 2-pole	69157-102HLF	Amphenol FCI
12	C1, C3, C10, C11, C26, C54, C57 to C62	Capacitor, 0.1 μ F, 16 V, 10%, C0402, X7R	530L104KT16T	American Technical Ceramics
10	C2, C9, C12, C28, C52, C53, C63, C87, C89, C90	Capacitor, 0.01 μ F, 25 V, 10%, C0402, X7R	C1005X7R1E103K050EB	TDK
2	C24, C29	Capacitor, 0.1 μ F, 50 V, 10%, C0402, X7R	C1005X7R1H104K050BE	TDK
4	C31, C36, C38, C56	Capacitor, 4.7 μ F, 25 V, 10%, C1206H71, X7R	C1206C475K3RACTU	KEMET
2	C34, C37	Capacitor, 1 μ F, 100 V, 10%, C0805, ceramic X7S	C2012X7S2A105K	TDK
2	C4, C39	Capacitor, 0.001 μ F, 3000 V, 10%, C1812H71, X7R	C1812C102KHRACTU	KEMET
2	C41, C42	Capacitor, 12 pF, 50 V, 1%, C0402, NPO (COG)	GJM1555C1H120FB01D	Murata
3	C44, C47, C48	Capacitor, 4.7 μ F, 10 V, 10%, C0603, X6S	GRM185C81A475KE11D	Murata
13	C64, C66 to C69, C73, C74, C76, C78 to C81, C85	Capacitor, 0.1 μ F, 50 V, 10%, C0402, X7R	CGA2B3X7R1H104K050BB	TDK
1	C65	Capacitor, 4.7 μ F, 50 V, 10%, C0805, ceramic, X7R, general-purpose	GRM21BZ71H475KE15L	Murata
2	C70, C72	Capacitor, 10 μ F, 25 V, 10%, C0805, X5R	C2012X5R1E106K085AC	TDK
2	C71, C77	Capacitor, 8 pF, 16 V, 10%, C0402, COG	0402YA8R0DAT2A	AVX Corporation
2	C75, C82	Capacitor, 20 pF, 16 V, 5%, C0402, COG	0402YA200JAT2A	AVX Corporation
2	C83, C84	Capacitor, 0.47 μ F, 35 V, 10%, C0603, X7R	GMK107B7474KAHT	TAIYO YUDEN
2	C86, C88	Capacitor, 2.2 μ F, 50 V, 10%, C0805, X7R	UMK212BB7225KG-T	TAIYO YUDEN
1	D3	6 V, SOT23_6, TVS array, low capacitance electrostatic discharge (ESD) protection	SP0504SHTG	Littelfuse, Inc.
3	DS1, DS4, DS5	1.7 V, LED red clear, 660 nm	SML-LX0805SRC-TR	Lumex, Inc.
1	DS7	LED green surface-mount device	APHHS1005ZGC	Kingbright
1	DS8	LED hyper red SMD	APHHS1005SURCK	Kingbright
1	E2	Ferrite bead, 1 k Ω , 0805	BK2125HS102-T	TAIYO YUDEN
1	EXT_5V	PCB connector header 3.81 mm	1803277	Phoenix Contact
1	JP2	Jumper, 3-position, male unshrouded single row, 2.54 mm pitch, 3 mm solder tail	M20-9990345	Harwin
3	L1, L3, L5	Inductor, 10 nH, 2%, L0603, wire wound	LQW18AN10NG10D	Murata Manufacturing
4	L6 to L9	Inductor, 120 nH, 25%, L0805	BLM21BB750SN1B	Murata Manufacturing
1	P1	RJ45, single port, shielded	5406299-1	TE Connectivity
1	P3	PCB connector, single-ended array, male 160-position, FMC	ASP-134604-01	Samtec
1	P4	PCB connector	PJ-002AH-SMT-TR	CUI
1	P5	PCB connector, 8-position, socket strip, double row, right angled, 2.54 mm pitch	SSW-104-02-T-D-RA	Samtec Inc.
1	P7	PCB connector, right angled, male header	TSW-104-08-T-D-RA	Samtec
1	P8	PCB connector, female, mini USB2.0	UX60SC-MB-5S8	Hirose Electric
1	Q2	45 V SOT23-M3, NPN transistor	BC817	NXP Semiconductors
1	R1	Resistor, 3.01 k Ω , 1%, R0402	ERJ-2RKF3011X	Panasonic

Qty	Reference Designator	Description	Supplier	Device Number
20	R6, R10, R26, R53, R63, R80, R84, R87, R88, R90, R92, R112, R148, R150, R194, R195, R196, R210, R211, R213	Resistor, 0 Ω, 50 V, 1%, R0402	MC00625W040210R	Multicomp (SPC)
6	R39, R103, R115, R117, R207, R209	Resistor, 56 kΩ, 1%, R0603	MC 0.063W 0603 1% 56K.	Multicomp (SPC)
14	R24, R33, R34, R40, R51, R69, R70, R104, R114, R116, R118, R197, R206, R208	Resistor, 10 kΩ, not applicable, 1%, R0603	MC0063W0603110K	Multicomp (SPC)
2	R75, R106	Resistor, 1 kΩ, 1%, R0603	MC0063W060311K	Multicomp (SPC)
2	R107, R145	Resistor, 1.5 kΩ, 50 V, 1%, R0603	MC 0.063W 0603 1% 1K5	Multicomp (SPC)
1	R11	Resistor, 280 kΩ, not applicable, 0.1%, R0603	ERA-3AEB2803V	Panasonic
4	R72, R74, R113, R144	Resistor, 0 Ω, 1%, R0603	MC0603WG00000T5 E-TC	Multicomp (SPC)
2	R12, R52	Resistor, 50 kΩ, 0.1%, R0603	PNM0603E5002BST5	Vishay
1	R121	Resistor, 1 MΩ, 1%, R0201	ERJ-1GNF1004C	Panasonic
1	R122	Resistor, 4.7 kΩ, 25 V, 1%, R0201	MC0201L6F4701SE	Multicomp (SPC)
6	R123, R124, R130, R131, R135, R136	Resistor, 100 kΩ, not applicable, 1%, R0201	ERJ-1GNF1003C	Panasonic
2	R125, R137	Resistor, 1 kΩ, 1%, R0201	ERJ-1GNF1001C	Panasonic
3	R126, R128, R129	Resistor, 33 Ω, 1%, R0201	ERJ-1GNF33R0C	Panasonic
1	R127	Resistor, 0 Ω, 5%, R0201	CR0201-J/-000GLF	Bourns
3	R132, R133, R134	Resistor, 100 Ω, 1%, R0201	ERJ-1GNF1000C	Panasonic
1	R149	Resistor, 82 kΩ, 1%, R0603	MC 0.063W 0603 1% 82K	Multicomp (SPC)
1	R16	Resistor, 200 kΩ, 1%, R0603	ERJ-3EKF2003V	Panasonic
1	R192	Resistor, 100 kΩ, 1%, R0603	RC0603JR-07100KL	Yageo
1	R193	Resistor, 10 kΩ, 1%, R0402	ERJ-2RKF1002X	Panasonic
4	R2 to R5	Resistor, 75 Ω, 1%, R0603	ERJ-3EKF75R0V	Panasonic
1	R43	Resistor, 390 Ω, 5%, R0402	ERJ-2GEJ391X	Panasonic
2	R7, R46	Resistor, 470 Ω, 1%, R0402	RC0402FR-07470RL	Yageo
6	R50, R81, R86, R89, R93, R99	Resistor, 10 Ω, 1%, R0402	MC00625W0402110R	Multicomp (SPC)
1	S1	Switch rotary selector, 2-position, surface mount	CS-4-12XTA	NIDEC COPAL ELECTRONICS
3	S2, S5, S6	Switches, tactile, microminiature top actuated, single pole, single throw, normally open (SPST-NO)	PTS830 GM140 SMTR LFS	C&K
3	S3, S4, S9	Switch, rotary SP4T (single pole, 4 throw)	CS-4-14NA	Nidec Copal Electronics
1	T1	Transformer, 10 BASE-Te, 100 BASE-TX modules 1:1 turns ratio	HX1260NL	Pulse Electronics
1	U1	IC, robust, industrial low power 10 Mbps/100 Mbps Ethernet PHY	ADIN1200	Analog Devices
1	U10	IC, USB to UART	FT232RQ	Future Technology Devices International, Ltd. (FTDI Chip)
1	U11	IC, TTL single AND gate, SC70-5	SN74LVC1G08DCKR	Texas Instruments
1	U12	IC, 3.3 V linear regulator	ADP124ARHZ-3.3-R7	Analog Devices
3	U3, U13, U14	IC, dual supply transceiver, three-state	74AVC1T45GW,125	NXP Semiconductors
1	U4	IC, dual, 300 mA adjustable output, low noise, high power supply rejection ratio voltage regulator	ADP223ACPZ-R7	Analog Devices
1	U7	IC, I ² C-compatible serial EEPROM 2 kB	AT24C02D-SSHM-T	ATMEL

Qty	Reference Designator	Description	Supplier	Device Number
1	U9	IC, ultralow power Arm® Cortex-M3 micro-controller with integrated power management and 256 kB of embedded flash memory	ADUCM3029BCPZ	Analog Devices
1	Y1	Crystal, 25 MHz, 10 ppm, 10 pF load capacitor	FA-128_25.000000MHZ_10.0_+10-10	Seiko Epson
1	Y2	Crystal, 32.768 kHz, 20 ppm, 6 pF load capacitor	ABS07-120-32.768KHZ-T	Abracon Corp.
1	Y3	Crystal, 26 MHz, 30 ppm, 0 pF load capacitor	ECS-260-10-36Q-ES-TR	ECS, INC.

Table 8. Not Populated

Qty	Reference Designator	Description	Supplier	Device Number
15	12V_FPGA, GND1, GND3, GND5, GPCLK, INT_N, LDO_CAP, LED_0, LINK_ST, MDC, MDIO, P9, P10, P11, SUPPLY	Test point, do not insert	1405-2	Keystone Electronics
5	C5, C6, C18, C55, C92	Capacitor, 0.1 µF, 16 V, 10 %, C0402, X7R	530L104KT16T	American Technical Ceramics
4	C33, C45, C91, C99	Capacitor, 0.01 µF, 25 V, 10%, 0402, X7R	TDK	C1005X7R1E103K050EB
1	J1	PCB connector, straight SubMiniature Version A (SMA)	TE Connectivity LTD	5-1814832-1
8	R49, R65, R67, R95, R97, R101, R111, R120	Resistor, 0 Ω, 50 V, 1%, 0402	Multicomp (SPC)	MC00625W040210R
4	R138 to R141	Resistor, 0 Ω, R0805	Multicomp (SPC)	MC 0.1W 0805 0R
1	R19	Resistor, 1 MΩ, 1%, 0402	Panasonic	ERJ-2RKF1004X
12	R8, R9, R22, R23, R27 to R32, R37, R38	Resistor, 10 kΩ, 1%, 0603	Multicomp (SPC)	MC0063W0603110K
1	R85	Resistor 10 Ω, 1%, R0402	Multicomp (SPC)	MC00625W0402110R
1	SHIELD	PCB connector, 4 mm socket	Rapid	20054

NOTES

I²C refers to a communications protocol originally developed by Philips Semiconductors (now NXP Semiconductors).



ESD Caution

ESD (electrostatic discharge) sensitive device. Charged devices and circuit boards can discharge without detection. Although this product features patented or proprietary protection circuitry, damage may occur on devices subjected to high energy ESD. Therefore, proper ESD precautions should be taken to avoid performance degradation or loss of functionality.

Legal Terms and Conditions

By using the evaluation board discussed herein (together with any tools, components documentation or support materials, the "Evaluation Board"), you are agreeing to be bound by the terms and conditions set forth below ("Agreement") unless you have purchased the Evaluation Board, in which case the Analog Devices Standard Terms and Conditions of Sale shall govern. Do not use the Evaluation Board until you have read and agreed to the Agreement. Your use of the Evaluation Board shall signify your acceptance of the Agreement. This Agreement is made by and between you ("Customer") and Analog Devices, Inc. ("ADI"), with its principal place of business at One Technology Way, Norwood, MA 02062, USA. Subject to the terms and conditions of the Agreement, ADI hereby grants to Customer a free, limited, personal, temporary, non-exclusive, non-sublicensable, non-transferable license to use the Evaluation Board FOR EVALUATION PURPOSES ONLY. Customer understands and agrees that the Evaluation Board is provided for the sole and exclusive purpose referenced above, and agrees not to use the Evaluation Board for any other purpose. Furthermore, the license granted is expressly made subject to the following additional limitations: Customer shall not (i) rent, lease, display, sell, transfer, assign, sublicense, or distribute the Evaluation Board; and (ii) permit any Third Party to access the Evaluation Board. As used herein, the term "Third Party" includes any entity other than ADI, Customer, their employees, affiliates and in-house consultants. The Evaluation Board is NOT sold to Customer; all rights not expressly granted herein, including ownership of the Evaluation Board, are reserved by ADI. CONFIDENTIALITY. This Agreement and the Evaluation Board shall all be considered the confidential and proprietary information of ADI. Customer may not disclose or transfer any portion of the Evaluation Board to any other party for any reason. Upon discontinuation of use of the Evaluation Board or termination of this Agreement, Customer agrees to promptly return the Evaluation Board to ADI. ADDITIONAL RESTRICTIONS. Customer may not disassemble, decompile or reverse engineer chips on the Evaluation Board. Customer shall inform ADI of any occurred damages or any modifications or alterations it makes to the Evaluation Board, including but not limited to soldering or any other activity that affects the material content of the Evaluation Board. Modifications to the Evaluation Board must comply with applicable law, including but not limited to the RoHS Directive. TERMINATION. ADI may terminate this Agreement at any time upon giving written notice to Customer. Customer agrees to return to ADI the Evaluation Board at that time. LIMITATION OF LIABILITY. THE EVALUATION BOARD PROVIDED HEREUNDER IS PROVIDED "AS IS" AND ADI MAKES NO WARRANTIES OR REPRESENTATIONS OF ANY KIND WITH RESPECT TO IT. ADI SPECIFICALLY DISCLAIMS ANY REPRESENTATIONS, ENDORSEMENTS, GUARANTEES, OR WARRANTIES, EXPRESS OR IMPLIED, RELATED TO THE EVALUATION BOARD INCLUDING, BUT NOT LIMITED TO, THE IMPLIED WARRANTY OF MERCHANTABILITY, TITLE, FITNESS FOR A PARTICULAR PURPOSE OR NON-INFRINGEMENT OF INTELLECTUAL PROPERTY RIGHTS. IN NO EVENT WILL ADI AND ITS LICENSORS BE LIABLE FOR ANY INCIDENTAL, SPECIAL, INDIRECT, OR CONSEQUENTIAL DAMAGES RESULTING FROM CUSTOMER'S POSSESSION OR USE OF THE EVALUATION BOARD, INCLUDING BUT NOT LIMITED TO LOST PROFITS, DELAY COSTS, LABOR COSTS OR LOSS OF GOODWILL. ADI'S TOTAL LIABILITY FROM ANY AND ALL CAUSES SHALL BE LIMITED TO THE AMOUNT OF ONE HUNDRED US DOLLARS (\$100.00). EXPORT. Customer agrees that it will not directly or indirectly export the Evaluation Board to another country, and that it will comply with all applicable United States federal laws and regulations relating to exports. GOVERNING LAW. This Agreement shall be governed by and construed in accordance with the substantive laws of the Commonwealth of Massachusetts (excluding conflict of law rules). Any legal action regarding this Agreement will be heard in the state or federal courts having jurisdiction in Suffolk County, Massachusetts, and Customer hereby submits to the personal jurisdiction and venue of such courts. The United Nations Convention on Contracts for the International Sale of Goods shall not apply to this Agreement and is expressly disclaimed.

©2019 Analog Devices, Inc. All rights reserved. Trademarks and registered trademarks are the property of their respective owners.
UG22009-0-11/19(0)



www.analog.com

Looking for pricing, stock, or lifecycle information?

Click below to explore more details on WIN SOURCE:

- ⊖ [View EVAL-ADIN1200FMCZ on WIN SOURCE](#)
- ⊖ [Analog Devices Inc. Information](#)

Optimize Your Supply Chain with WIN SOURCE Solutions

- ✓ Global Sourcing Solution
- ✓ Obsolete Management
- ✓ Cost Control Management
- ✓ Shortage Management
- ✓ Alternative Solution
- ✓ Excess Inventory Management