



**THE DATASHEET OF
EVAL-ADV7182AEBZ**



Evaluation Board for the **ADV7182A** 10-Bit, SDTV Video Decoder with Differential Inputs

FEATURES

Four video input ports capable of accepting any of the following formats: single-ended CVBS, differential CVBS, S-Video (Y/C), and component (YPbPr)
 Digital (ITU-R BT.656) and YPbPr outputs

EVALUATION BOARD KIT CONTENTS

EVAL-ADV7182AEBZ evaluation board
 7.5 V power supply block
 USB cable

HARDWARE NEEDED

Source of one or more of the following video inputs: single-ended CVBS, differential CVBS, S-Video (Y/C), and/or component (YPbPr)

PC

TV or display with YPbPr input

CVBS input cable(s)

S-Video cable(s)

Component cable(s)

SOFTWARE NEEDED

[DVP Evaluation Software](#)

[ADV7182A](#) script

Windows OS

GENERAL DESCRIPTION

The EVAL-ADV7182AEBZ evaluation kit is the platform provided by Analog Devices, Inc., to evaluate the [ADV7182A](#) video decoder. The EVAL-ADV7182AEBZ evaluation kit contains an EVAL-ADV7182AEBZ evaluation board and all of its necessary peripherals.

This user guide provides a detailed overview of the EVAL-ADV7182AEBZ evaluation board hardware and the software required to use it.

The [ADV7182A](#) data sheet should be consulted in conjunction with this user guide when using the EVAL-ADV7182AEBZ evaluation board.

[EngineerZone](#) can be accessed to find additional information on the [ADV7182A](#).

PHOTOGRAPH OF THE EVAL-ADV7182AEBZ EVALUATION BOARD

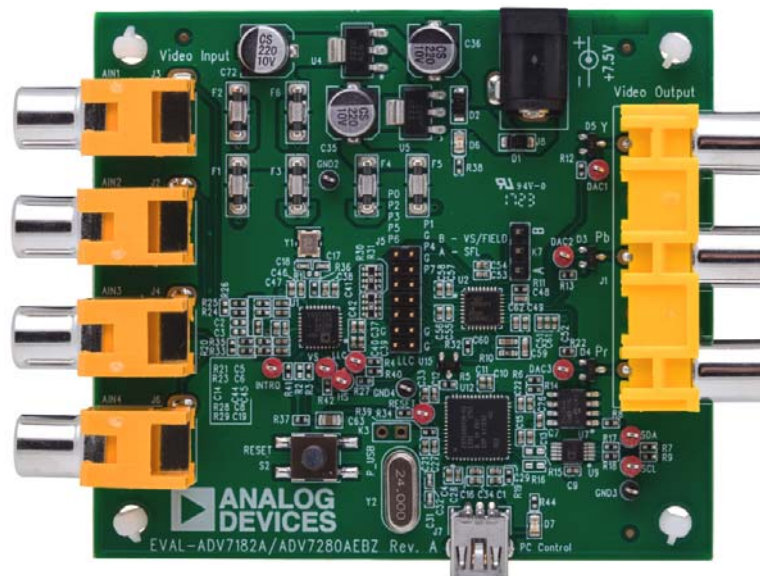

Figure 1.

16020-001

TABLE OF CONTENTS

Features	1	Evaluation Board Description	4
Evaluation Board Kit Contents	1	Evaluation Board Software.....	7
Hardware Needed	1	Software Required	7
Software Needed	1	Downloading the ADV7182A Script Files.....	7
General Description	1	Downloading DVP Eval Software.....	7
Photograph of the EVAL-ADV7182AEBZ.....	1	Installing DVP Eval Software	7
Revision History	2	Loading the ADV7182A Script Files	7
Evaluation Board Hardware.....	3	Configuring the Evaluation Board.....	8
Evaluation Board Overview	3		

REVISION HISTORY

8/2017—Revision 0: Initial Version

EVALUATION BOARD HARDWARE

EVALUATION BOARD OVERVIEW

The EVAL-ADV7182AEBZ evaluation board features an [ADV7182A](#) video decoder and an [ADV7391](#) video encoder. Four analog video inputs (A_{IN1} to A_{IN4}) are connected to the [ADV7182A](#) video decoder. The [ADV7182A](#) can receive analog video in several different format configurations; hardware configuration changes might be required to support certain formats, for example, single-ended CVBS vs. differential CVBS (see Table 1). The [ADV7182A](#) converts the analog video received into an ITU-R BT.656-compatible digital stream. The digital stream is connected to the [ADV7391](#) video encoder. The [ADV7391](#) converts the digital stream back into analog video that is output via three analog video outputs.

Analog Video Input Format Configurations

Configuring A_{IN3} and A_{IN4} for Single-Ended CVBS

To configure the A_{IN3} and A_{IN4} inputs to receive single-ended CVBS, make the following resistor changes on the evaluation board:

1. Remove Resistor R20.
2. Replace Resistor R33 and Resistor R35 with 24 Ω resistors.
3. Replace Resistor R28 and Resistor R29 with 51 Ω resistors.

Configuring A_{IN1} and A_{IN2} for Differential CVBS

To configure A_{IN1} and A_{IN2} to receive differential CVBS, make the following resistor changes on the evaluation board:

1. Replace Resistor R24 and Resistor R25 with 1.3 k Ω resistors
2. Replace Resistor R21 and Resistor R23 with 430 Ω resistors.
3. Replace Resistor R26 with a 75 Ω resistor for pseudo differential CVBS or with a 150 Ω resistor for fully differential CVBS.
4. Connect the positive input to A_{IN1} and the negative input to A_{IN2} .

Configuring A_{IN3} and A_{IN4} for S-Video (Y/C)

To configure A_{IN3} and A_{IN4} to receive S-Video (Y/C), make the following resistor changes on the evaluation board:

1. Remove Resistor R20.
2. Replace Resistor R33 and Resistor R35 with 24 Ω resistors.
3. Replace Resistor R28 and Resistor R29 with 51 Ω resistors.
4. Connect the luma channel (Y) to A_{IN3} and the chroma channel (C) to A_{IN4} .

Configuring A_{IN1} , A_{IN2} , and A_{IN3} for YPrPb

To configure A_{IN1} , A_{IN2} , and A_{IN3} to receive YPrPb, make the following resistor changes on the evaluation board:

1. Remove Resistor R20.
2. Replace Resistor R33 and Resistor R35 with 24 Ω resistors.
3. Replace Resistor R28 and Resistor R29 with 51 Ω resistors.
4. Connect the luma channel (Y) to A_{IN1} , the Pb channel to A_{IN2} , and the Pr channel to A_{IN3} .

Table 1. Analog Video Input Format Configurations for the EVAL-ADV7182AEBZ Evaluation Board

Configuration	A_{IN1}	A_{IN2}	A_{IN3}	A_{IN4}
Default	Single-Ended CVBS Input 1	Single-Ended CVBS Input 2	Differential CVBS Input 1, positive channel	Differential CVBS Input 1, negative channel
Single-Ended (SE) CVBS	Default	Default	See the Configuring A_{IN3} and A_{IN4} for Single-Ended CVBS section	See the Configuring A_{IN3} and A_{IN4} for Single-Ended CVBS section
Differential CVBS	See the Configuring A_{IN1} and A_{IN2} for Differential CVBS section	See the Configuring A_{IN1} and A_{IN2} for Differential CVBS section	Default	Default
S-Video (Y/C)	S-Video Input 1 (Y-channel)	S-Video Input 1 (C-channel)	See the Configuring A_{IN3} and A_{IN4} for S-Video (Y/C) section	See the Configuring A_{IN3} and A_{IN4} for S-Video (Y/C) section
Component (YPbPr)	See the Configuring A_{IN1} , A_{IN2} , and A_{IN3} for YPrPb section	See the Configuring A_{IN1} , A_{IN2} , and A_{IN3} for YPrPb section	See the Configuring A_{IN1} , A_{IN2} , and A_{IN3} for YPrPb section	Not applicable

EVALUATION BOARD DESCRIPTION

This section outlines how to power up, communicate with, and use the evaluation board. For an outline of the evaluation board connections, see Figure 2.

Power Supply

To power up the evaluation board, connect a mains cable to the 7.5 V power supply block included in the EVAL-ADV7182AEBZ evaluation kit. Connect the output jack plug of the 7.5 V power supply block to the input power connector (J8) on the evaluation board. LED D6 illuminates when the power supply is enabled and successfully connects to the evaluation board.

Only use the 7.5 V power supply block provided with the evaluation kit to power the evaluation board.

Communicating with the Evaluation Board

To establish communication with the evaluation board, connect the USB cable included in the EVAL-ADV7182AEBZ evaluation kit to a computer with [DVP Eval Software](#) installed. Connect the USB cable to the USB connector (J7) on the evaluation board. LED D7 illuminates when the USB cable successfully connects between an active USB port and the evaluation board.

Connecting Input Video

Connect an analog video input(s) to the desired analog input (A_{IN1} to A_{IN4}) of the evaluation board. Refer to Table 1 to determine how different types of input (for example, single-ended CVBS and S-Video) connect to the evaluation board. Refer to the [ADV7182A](#) data sheet for more information on input muxing options.

Connecting Output Video

To observe the output of the evaluation board, connect a YPrPb cable from the analog video output connector (J1) of the evaluation board to a television or other sink device.

Ensure the television or other sink device supports the output format of the evaluation board (480i/576i).

Probing the Digital Video Stream

ADV7182AEBZ output stream of the [ADV7182A](#) can be probed with an oscilloscope or a logic analyzer via a header (J5) on the evaluation board. There are also individual test points for the LLC, HS, and VS/FIELD/SFL signals.

Other Considerations

The 28.63636 MHz crystal (Y1) on the evaluation board does not oscillate until the [ADV7182A](#) is configured (see the [Configuring the Evaluation Board](#) section). The I²C master works independently of the crystal, using a ring-oscillator in the [ADV7182A](#).

Specific components on the evaluation board are outlined in Table 2 and highlighted in Figure 3. Additional details on components are outlined in Table 3.

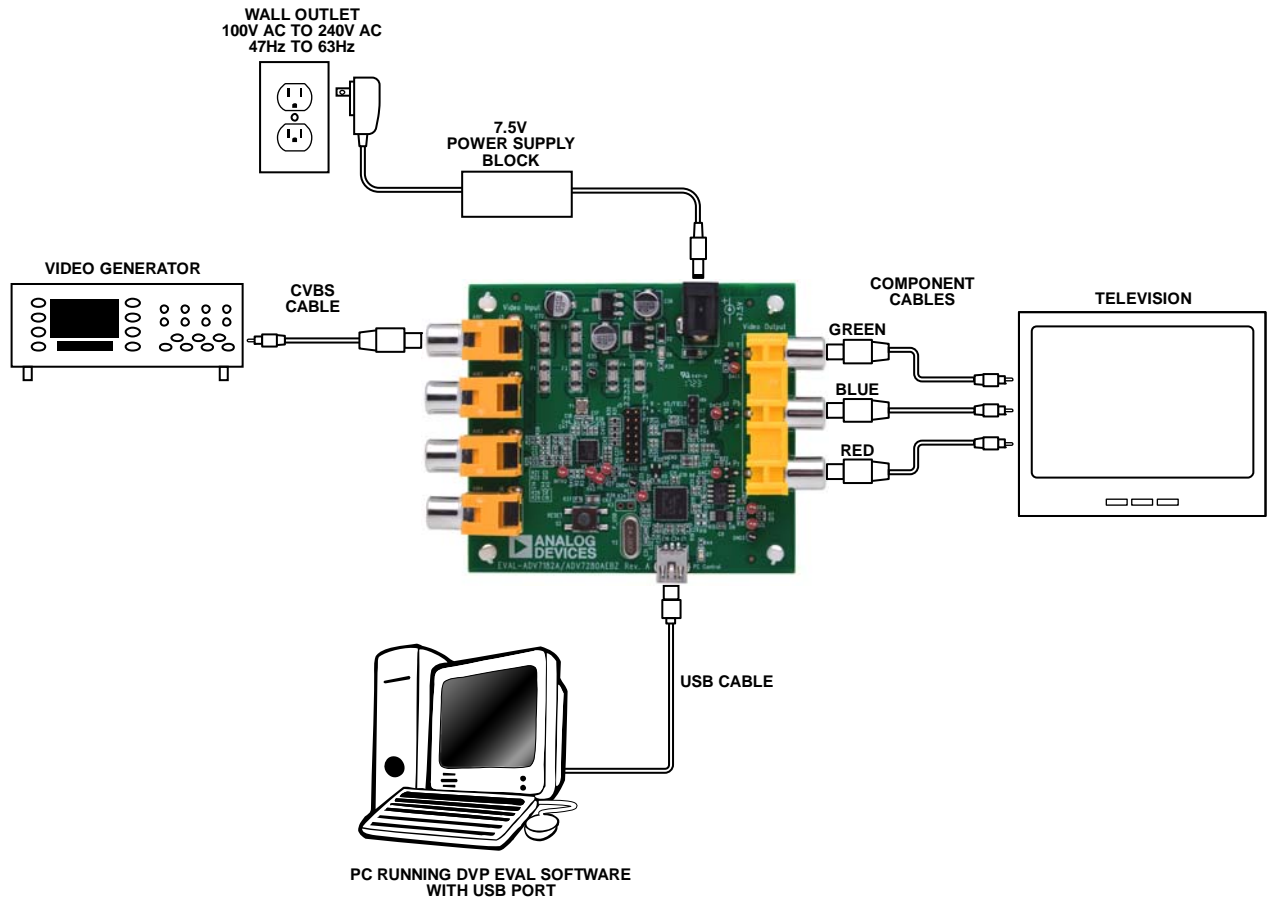

16020-102

Figure 2. Outline of Evaluation Board Connections

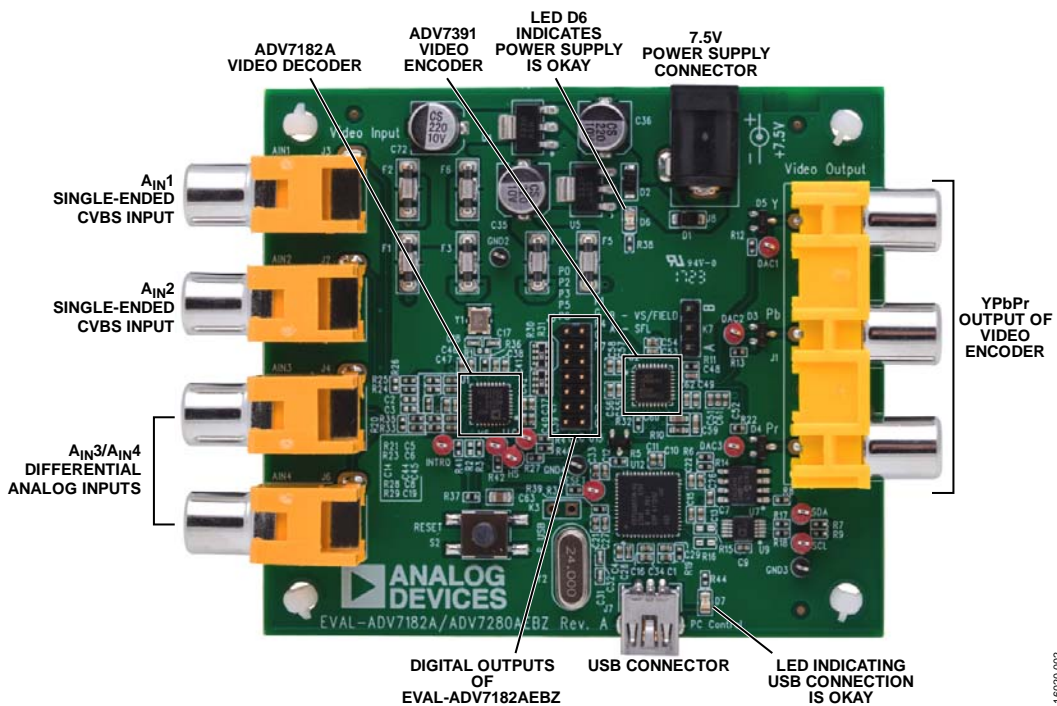

16020-002

Figure 3. ADV7182A Evaluation Board

Table 2. Essential Evaluation Board Components

Reference Designator	Function	Description
J2 to J4, J6	Analog video inputs	Analog video inputs (A _{IN1} to A _{IN4}) connected to the ADV7182A video decoder.
J1	Analog video output	Analog video outputs connected to the ADV7391 encoder.
J8	Power	Connection for 7.5 V power supply. A 7.5 V power supply block is included in the EVAL-ADV7182AEBZ evaluation kit.
D6	Power enabled LED	The LED illuminates when the 7.5 V supply is connected and enabled.
J7	USB	Connecting a USB cable between this connector and a PC with DVP Eval Software and ADV7182A scripts ¹ installed allows control of the evaluation board. See the Evaluation Board Software section for more information on DVP Eval Software and ADV7182A scripts.
D7	USB connected LED	The LED illuminates when the USB cable is connected between an active USB port on a PC and the evaluation board.

¹ These scripts enable control of the [ADV7182A](#) and the [ADV7391](#) encoder.

Table 3. Additional Evaluation Board Components

Reference Designator	Function	Description
J5	P0 to P7 digital outputs	P0 to P7 digital outputs. Digital video output from the ADV7182A .
LLC	LLC output	Line locked clock (LLC) output from the ADV7182A .
HS	HS output	Horizontal sync output from the ADV7182A .
VS	VS/FIELD/SFL output	Vertical sync/field/sub-carrier frequency lock output from the ADV7182A .
INTRQ	INTRQ output	Interrupt output from the ADV7182A .
DAC 1 to DAC 3	DAC 1 to DAC 3	The YPrPb outputs from the ADV7391 are accessible via the DAC1, DAC2, and DAC3 test points.
Reset and S2	Reset	The evaluation board can be reset by pressing and releasing the push button S2. The evaluation board can also be reset by momentarily connecting the Reset test point to 0V.
SDA and SCL	I ² C communication bus	Test points. The SDA (I ² C data) and SCL (I ² C clock) test points provide access to the I ² C communication bus on the evaluation board. This allows an external I ² C master to be connected instead of using a PC to configure the evaluation board.
K3	EEPROM programming	Never short Jumper K3 and only employ K3 during initial programming. This can disable the USB interface on the evaluation board.
K7	Synchronization control	Jumper K7 controls which synchronization signal is sent from the VS/FIELD/SFL pin of the ADV7182A to the ADV7391 encoder. If the VS/FIELD/SFL pin is configured for either vertical synchronization or field synchronization, place a jumper in Position A. If the VS/FIELD/SFL pin is configured for the subcarrier frequency lock (SFL) signal, place a jumper in Position B. Jumper K7 can be not inserted if none of the above cases are in use.

EVALUATION BOARD SOFTWARE

SOFTWARE REQUIRED

To complete the initial setup of the evaluation board, download the following:

- [ADV7182A](#) script files
- [DVP Eval Software](#)

DOWNLOADING THE [ADV7182A](#) SCRIPT FILES

To download the [ADV7182A](#) script files, complete the following steps:

1. Go to the [ADV7182A](#) product page.
2. Download the [ADV7182A_Cust.zip](#) file
3. Unzip the file [ADV7182A_Cust.zip](#) file

DOWNLOADING [DVP EVAL SOFTWARE](#)

To download the [DVP Eval Software](#), complete the following steps:

1. Open the [Install DVP Eval Software](#) thread on [EngineerZone](#).
2. Download the [Install DVP Eval Latest Source 10-14-11.exe.zip](#) file.
3. Unzip the [Install DVP Eval Latest Source 10-14-11.exe.zip](#) file.

INSTALLING THE [DVP EVAL SOFTWARE](#)

To install the [DVP Eval Software](#), complete the following steps:

1. Run the executable file [Install DVP Eval Latest Source 10-14-11.exe.zip](#).
2. Read the [Software License Agreement](#). If in agreement, click the **I Agree** button.
3. Select the desired **Desktop or Start Menu** shortcuts and click the **Next** button.
4. Select an installation destination folder and click the **Install** button (see Figure 4). It is recommended to use the default destination folder. Selecting a different destination folder can cause compatibility issues with some versions of Windows® OS.
5. Restart the PC after installing the [DVP Eval Software](#).

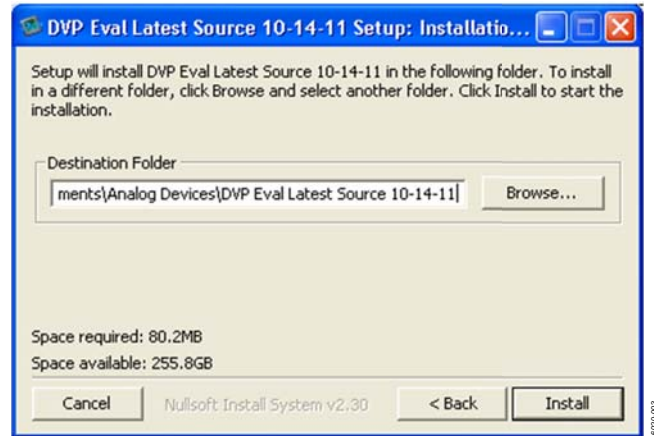

Figure 4. Installation Destination for [DVP Eval Software](#)

LOADING THE [ADV7182A](#) SCRIPT FILES

This section describes how to combine the [ADV7182A](#) script files with the [DVP Eval Software](#).

1. If possible, disconnect the PC from the internet, as some automatic backup agents can interfere with the script file loading process.
2. Copy the unzipped [ADV7182A_Cust](#) folder to the following directory: C:\Documents and Settings\USER_NAME\My Documents\Analog Devices\DVP Eval Latest Source 10-14-11\xml\New Boards
3. The location of this folder is influenced by the install location of the [DVP Eval Software](#) and USER_NAME must be defined by the user.
4. Open the [DVP Eval Software](#) by selecting **Start > All Programs > Analog Devices > DVP Eval Latest Source 10-14-11**.
5. Select **File > Update Boards** to combine the [ADV7182A](#) script files with the [DVP Eval Software](#). (see Figure 5).

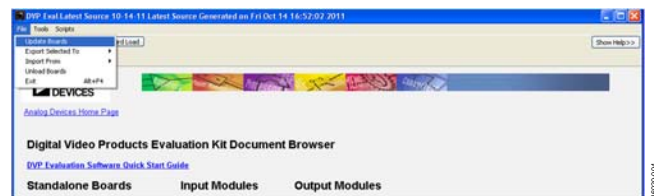

Figure 5. Update Board Files on the [DVP Eval Software](#)

6. After the **Update Boards** process completes, click **OK** on the **Update Boards Successful** window. The PC can now reconnect to the internet if it is disconnected.

CONFIGURING THE EVALUATION BOARD

After connecting and powering up the hardware and downloading and installing the software, begin using the evaluation board.

To configure the evaluation board, complete the following steps:

1. Select **Start > All Programs > Analog Devices > DVP Eval Latest Source 10-14-11**.
2. Click the **Choose Board** button in the top left corner of the **DVP Eval Software** window to open the **Board Selector** window (see Figure 6).

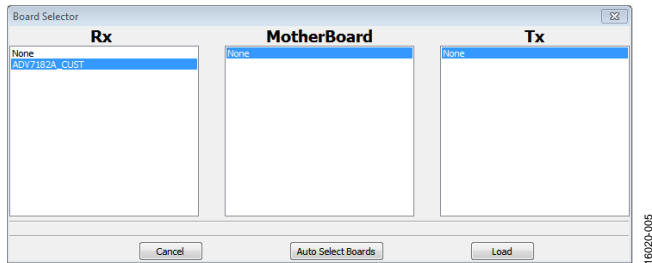

Figure 6. **Board Selector** Window of *DVP Eval Software*

3. Select **ADV7182A_CUST** in the **Rx** list box of the **Board Selector** window, select **None** in the **MotherBoard** list box and select **None** in the **Tx** list box.
4. Click the **Load** button. A window similar to Figure 7 appears.
5. Select **Scripts > ADV7182A_CUST** to select and run a script to configure the evaluation board (see Figure 8).
6. To monitor the registers of the **ADV7182A** or the **ADV7391**, click on the associated device tab within the **DVP Eval Software** (see Figure 8).

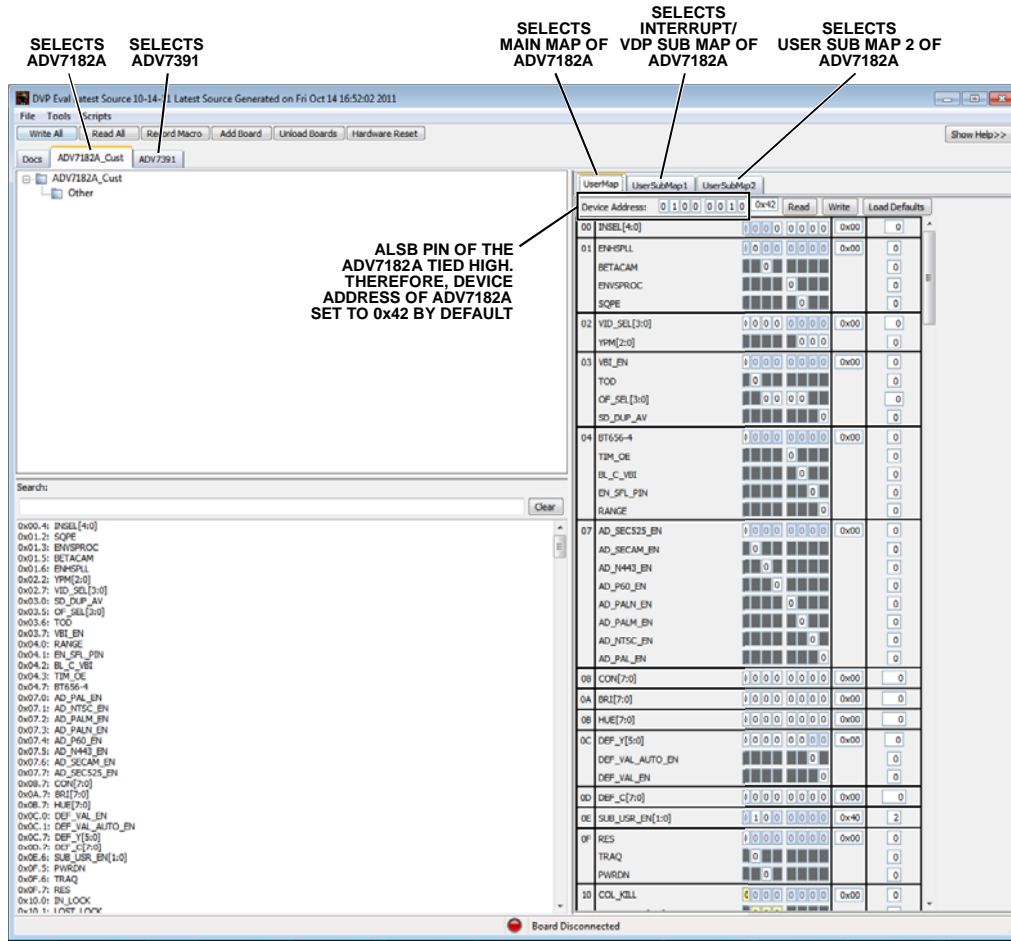

Figure 7. DVP Eval Software After Connecting the ADV7182A Evaluation Board

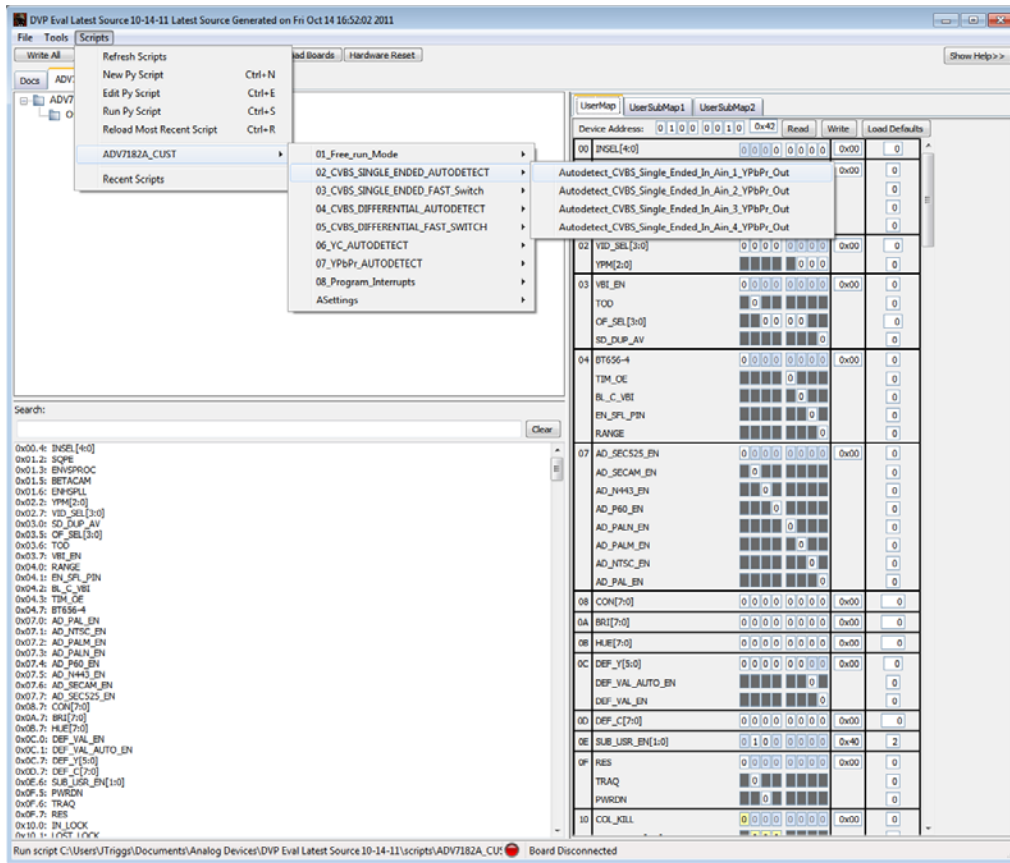

Figure 8. Running EVAL-ADV7182AEBZ Script on DVP Eval Software

I²C refers to a communications protocol originally developed by Philips Semiconductors (now NXP Semiconductors).



ESD Caution

ESD (electrostatic discharge) sensitive device. Charged devices and circuit boards can discharge without detection. Although this product features patented or proprietary protection circuitry, damage may occur on devices subjected to high energy ESD. Therefore, proper ESD precautions should be taken to avoid performance degradation or loss of functionality.

Legal Terms and Conditions

By using the evaluation board discussed herein (together with any tools, components documentation or support materials, the "Evaluation Board"), you are agreeing to be bound by the terms and conditions set forth below ("Agreement") unless you have purchased the Evaluation Board, in which case the Analog Devices Standard Terms and Conditions of Sale shall govern. Do not use the Evaluation Board until you have read and agreed to the Agreement. Your use of the Evaluation Board shall signify your acceptance of the Agreement. This Agreement is made by and between you ("Customer") and Analog Devices, Inc. ("ADI"), with its principal place of business at One Technology Way, Norwood, MA 02062, USA. Subject to the terms and conditions of the Agreement, ADI hereby grants to Customer a free, limited, personal, temporary, non-exclusive, non-sublicensable, non-transferable license to use the Evaluation Board FOR EVALUATION PURPOSES ONLY. Customer understands and agrees that the Evaluation Board is provided for the sole and exclusive purpose referenced above, and agrees not to use the Evaluation Board for any other purpose. Furthermore, the license granted is expressly made subject to the following additional limitations: Customer shall not (i) rent, lease, display, sell, transfer, assign, sublicense, or distribute the Evaluation Board; and (ii) permit any Third Party to access the Evaluation Board. As used herein, the term "Third Party" includes any entity other than ADI, Customer, their employees, affiliates and in-house consultants. The Evaluation Board is NOT sold to Customer; all rights not expressly granted herein, including ownership of the Evaluation Board, are reserved by ADI. CONFIDENTIALITY. This Agreement and the Evaluation Board shall all be considered the confidential and proprietary information of ADI. Customer may not disclose or transfer any portion of the Evaluation Board to any other party for any reason. Upon discontinuation of use of the Evaluation Board or termination of this Agreement, Customer agrees to promptly return the Evaluation Board to ADI. ADDITIONAL RESTRICTIONS. Customer may not disassemble, decompile or reverse engineer chips on the Evaluation Board. Customer shall inform ADI of any occurred damages or any modifications or alterations it makes to the Evaluation Board, including but not limited to soldering or any other activity that affects the material content of the Evaluation Board. Modifications to the Evaluation Board must comply with applicable law, including but not limited to the RoHS Directive. TERMINATION. ADI may terminate this Agreement at any time upon giving written notice to Customer. Customer agrees to return to ADI the Evaluation Board at that time. LIMITATION OF LIABILITY. THE EVALUATION BOARD PROVIDED HEREUNDER IS PROVIDED "AS IS" AND ADI MAKES NO WARRANTIES OR REPRESENTATIONS OF ANY KIND WITH RESPECT TO IT. ADI SPECIFICALLY DISCLAIMS ANY REPRESENTATIONS, ENDORSEMENTS, GUARANTEES, OR WARRANTIES, EXPRESS OR IMPLIED, RELATED TO THE EVALUATION BOARD INCLUDING, BUT NOT LIMITED TO, THE IMPLIED WARRANTY OF MERCHANTABILITY, TITLE, FITNESS FOR A PARTICULAR PURPOSE OR NONINFRINGEMENT OF INTELLECTUAL PROPERTY RIGHTS. IN NO EVENT WILL ADI AND ITS LICENSORS BE LIABLE FOR ANY INCIDENTAL, SPECIAL, INDIRECT, OR CONSEQUENTIAL DAMAGES RESULTING FROM CUSTOMER'S POSSESSION OR USE OF THE EVALUATION BOARD, INCLUDING BUT NOT LIMITED TO LOST PROFITS, DELAY COSTS, LABOR COSTS OR LOSS OF GOODWILL. ADI'S TOTAL LIABILITY FROM ANY AND ALL CAUSES SHALL BE LIMITED TO THE AMOUNT OF ONE HUNDRED US DOLLARS (\$100.00). EXPORT. Customer agrees that it will not directly or indirectly export the Evaluation Board to another country, and that it will comply with all applicable United States federal laws and regulations relating to exports. GOVERNING LAW. This Agreement shall be governed by and construed in accordance with the substantive laws of the Commonwealth of Massachusetts (excluding conflict of law rules). Any legal action regarding this Agreement will be heard in the state or federal courts having jurisdiction in Suffolk County, Massachusetts, and Customer hereby submits to the personal jurisdiction and venue of such courts. The United Nations Convention on Contracts for the International Sale of Goods shall not apply to this Agreement and is expressly disclaimed.

©2017 Analog Devices, Inc. All rights reserved. Trademarks and registered trademarks are the property of their respective owners. UG16020-0-8/17(0)



www.analog.com

Looking for pricing, stock, or lifecycle information?

Click below to explore more details on WIN SOURCE:

- ⊖ [View EVAL-ADV7182AEBZ on WIN SOURCE](#)
- ⊖ [Analog Devices Inc. Information](#)

Optimize Your Supply Chain with WIN SOURCE Solutions

- ✓ Global Sourcing Solution
- ✓ Obsolete Management
- ✓ Cost Control Management
- ✓ Shortage Management
- ✓ Alternative Solution
- ✓ Excess Inventory Management