



THE DATASHEET OF EVAL-ADUCM350EBZ



Evaluating the **ADuCM350** 16-Bit, Precision, Low Power Meter-on-a-Chip

FEATURES

ADuCM350 motherboard

Selection of daughter boards for analog front end and platform validation

3 power supply options: 2.5 V to 3.6 V from an external power supply, 5 V from interface/emulator board, or CR2032 battery connection

Interface options

UART and serial wire through 8-pin J-Link OB connector

Trace capability

Power indicator/general-purpose LEDs

Reset, download, and external interrupt push-buttons

Supercapacitor and thermistor capability

USB connectivity

8-pin connector to the interface/emulator board

Access to **ADuCM350** platform pins through Digital Header 1, Digital Header2, and CapTouch header

32.768 kHz external crystal and 16 MHz external crystal

EVALUATION KIT CONTENTS

EVAL-ADuCM350EBZ board

USB-SWD/UART-EMUZ, also known as J-Link OB emulator

AFE daughter boards: **ADuCM350** switch mux configuration board, **ADuCM350** 4-wire bio Configuration 2 board

ADuCM350 breakout board

ADuCM350 GPIO test header board

USB cable

ADDITIONAL EQUIPMENT AND SOFTWARE NEEDED

Evaluation software for the **ADuCM350** (download from the [ADuCM350 design resources](#) page)

Extra peripheral boards available for order: **Ev-ADuCM350AUDZ**, **Ev-ADuCM350DISZ**

See the [ADuCM350 design resources](#) page for more details

SYSTEM REQUIREMENTS

Minimum requirement to run examples and applications

PC with USB 2.0 controller connection and 1 free COM port

Windows XP SP3 or later, Windows Vista, or Windows 7 or later

ONLINE RESOURCES

Documents Needed

[ADuCM350](#) data sheet

[ADuCM350](#) hardware reference manual

[AN-1262](#), [AN-1263](#), [AN-1271](#), [AN-1281](#), [AN-1286](#),

[AN-1293](#), [AN-1302](#) application notes

[ADuCM350](#) software development kit quick start guide ([UG-677](#))

Required Software

[ADuCM350](#) software development kit (firmware/debug environment)

IAR Embedded Workbench for ARM (from Version 7.10+)

[ADuCM350](#) evaluation kit software platform (GUI software)

Design and Integration Files

[Schematics](#), [layout files](#), [bill of materials](#)

TYPICAL SETUP

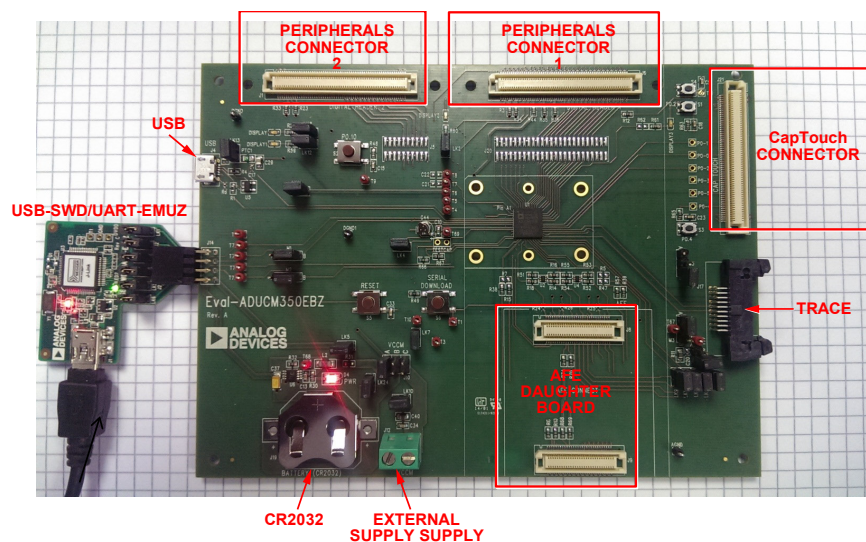

Figure 1. Typical Setup (USB-SWD/UART-EMUZ on Left and EVAL-ADuCM350EBZ on Right)

TABLE OF CONTENTS

Features	1	Jumper Settings.....	6
Evaluation Kit Contents.....	1	Evaluation Board Circuitry	7
Additional Equipment and Software Needed.....	1	J-Link OB Emulator	7
System Requirements.....	1	Digital Header Pad Lookup Table	8
Online Resources.....	1	ADuCM350 Motherboard Schematics.....	9
Typical Setup	1	ADuCM350 Daughter Board Schematics	16
Revision History	2	ADuCM350 Switch Mux Configuration Board	16
General Description	3	ADuCM350 4-Wire Bio Configuration 2 Board	18
Getting Started	4	Audio Daughter Board Reference Schematics	20
Software Installation Procedures.....	4	Display Board Reference Schematics.....	22
Evaluation Board Setup Procedures.....	4	Breakout Board Pin Connections	25
Evaluation Board Hardware.....	5	GPIO Test Header Board.....	26
Power Supplies	5	Limitations on Use and Liability	28

REVISION HISTORY

1/2018—Rev. 0 to Rev. A

Added Limitations on Use and Liability Section..... 28

5/2014—Revision 0: Initial Version

GENERAL DESCRIPTION

The [ADuCM350](#) is a 16 MHz ARM® Cortex-M3 processor with a high precision AFE specifically designed for high precision data acquisition.

The [ADuCM350](#) has a 16-bit precision analog core with four dedicated voltage measurement channels and up to eight current measurement channels. It has an integrated complex impedance measurement system and uses an integrated parameterizable waveform generator to generate complex waveforms. It uses an excitation amplifier control loop to perform accurate potentiostat type measurements and has a highly configurable switch matrix that allows application specific amplifier configuration.

The device has a large array of peripherals, including USB, CapTouch®, display, audio, and an array of serial interfaces and GPIOs.

The [ADuCM350](#) includes 384 kB of flash, 32 kB of SRAM, and 16 kB of flash configured as EEPROM.

The [EVAL-ADuCM350EBZ](#) kit provides scientists, system analyzers, and software developers a platform to migrate from sensor investigation and analysis to full ecosystem development. The evaluation kit consists of an [ADuCM350](#) motherboard and a selection of analog front end and digital peripheral daughter boards.

The evaluation kit is designed specifically to work with the [ADuCM350](#) software development kit (SDK) and the evaluation kit support package (EKSP)—both of which are available for download on the [ADuCM350 design resources](#) page.

The software development kit is designed to work with the IAR debugging environment only. The user guide for the [ADuCM350](#) SDK is available on the SDK installer.

An example of where the kit is downloaded follows: **C:\Analog Devices\ADuCM350BBCZ\Eval-ADUCM350EBZ\doc**

The SDK quick start guide and the EKSP user guide are available in the **Support Documentation** zipped folder.

GETTING STARTED

SOFTWARE INSTALLATION PROCEDURES

For software installation procedures, refer to the following [ADuCM350](#) software documentation for further details:

- For more information about the EKSP LabVIEW® GUI, refer to the EKSP user guide ([ADuCM350_Evaluation_Kit_Software_Platform.pdf](#)) within the **Documentation** folder of the software development kit.
- For more information about the SDK firmware/debug environment, refer to SDK user guide ([ADuCM350BBCZ_Software_Users_Guide.pdf](#)) within the **Documentation** folder of the software development kit and to the [ADuCM350](#) software development kit quick start guide, [UG-677](#).

EVALUATION BOARD SETUP PROCEDURES

1. Plug the [ADuCM350](#) switch mux configuration board into the [ADuCM350](#) evaluation board, [EVAL-ADuCM350EBZ](#).
2. Plug the USB-SWD/UART-EMUZ board into J14 on the [ADuCM350](#) evaluation board, [EVAL-ADuCM350EBZ](#).
3. Plug the USB cable into the USB-SWD/UART-EMUZ board.

After the drivers are downloaded, you can begin communicating with the board.

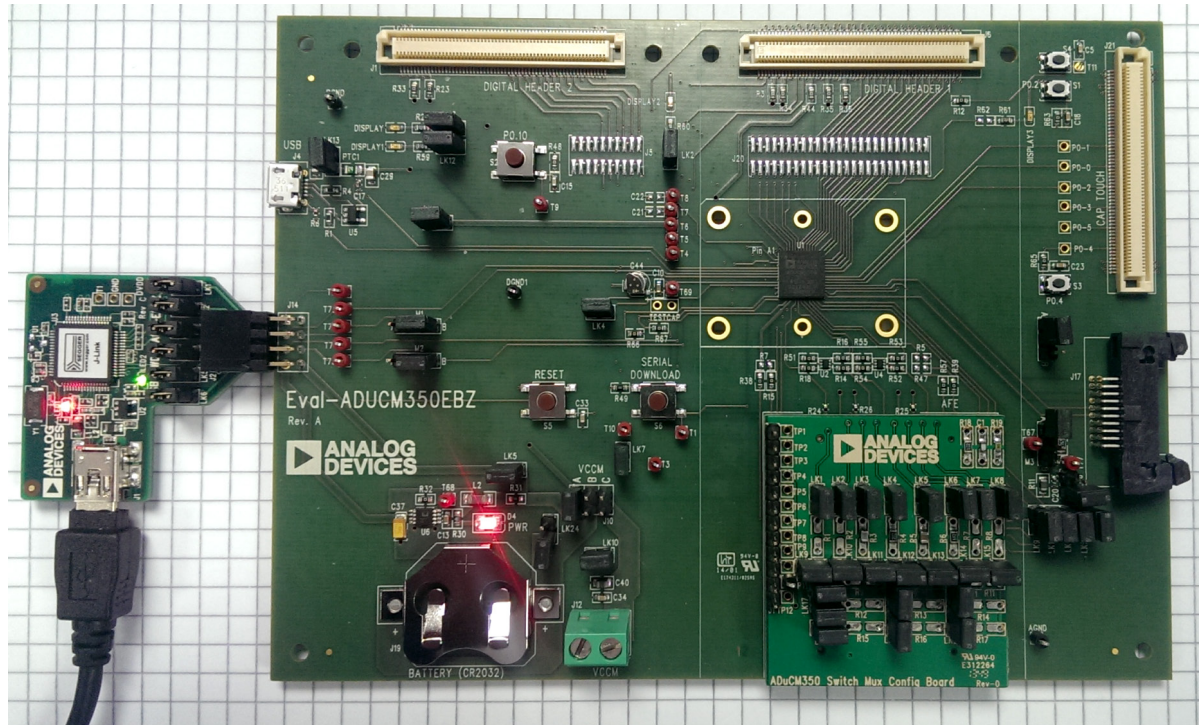

Figure 2. EVAL-ADuCM350EBZ Setup

12104-003

EVALUATION BOARD HARDWARE

POWER SUPPLIES

VCCM_ANA

Table 1 describes the three options for supplying power to the VCCM_ANA pin.

Table 1. VCCM_ANA Supply Options

Link J10 Position	VCCM_ANA Supply
A (Default Position)	Regulated 3.3 V from J3 wall socket supplied with board
B	CR2032 battery connection, J19
C	External supply

VDD_IO

Table 2 describes the two options for supplying power to the VDD_IO pin.

Table 2. VDD_IO Supply Options

Link M5 Position	VDD_IO Supply
A (Default Position)	From VCCM_ANA
B	Regulated 3.3 V from J3 wall socket (supplied with board)

VLCDVDD

Table 3 describes the three options for supplying power to the VLCDVDD pin.

Table 3. VLCDVDD Supply Options

LK14 Position ¹	VLCDVDD Supply
Inserted	Powered by VCCM
Open	Not powered

¹ The default position for LK14 is to be removed.

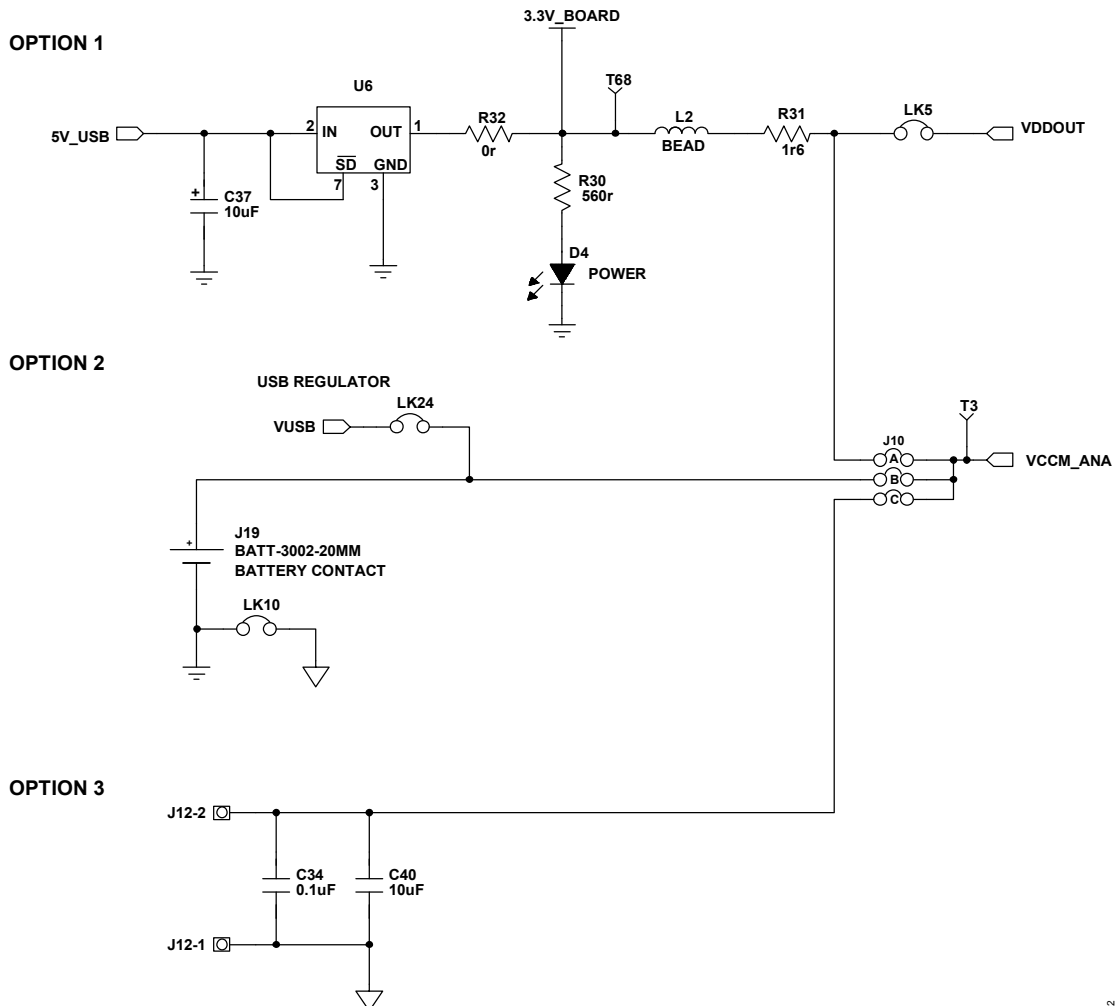

NOTES
1. LK24 IS NOT INSERTED BY DEFAULT.

Figure 3. Power Supply Schematic for VCCM_ANA Pin
Rev. A | Page 5 of 28

12104-002

JUMPER SETTINGS

Table 4. Link Option Functions

Link Number	Default Position	Function
LK1	Short	AN_A to AFE daughter board.
LK2	Open	LED GPIO functionality of P2.1.
LK3	Open	AN_B to AFE daughter board.
LK4	Short	Connect the supercapacitor to the VBACK pin.
LK6	Open	Thermistor voltage output measurement (AN_A).
LK7	Open	VCCM_DIG to VCCM_ANA external connection (connected internally on chip).
LK8	Short	LED GPIO functionality of P0.11.
LK9	Open	AN_C to AFE daughter board.
LK10	Short	AGND To DGND connector.
LK11	Open	AN_D to AFE daughter board.
LK12	Short	LED GPIO functionality of P4.2.
LK13	Short	VBUS link.
LK14	Open	Supply for VLCDVDD.
LK24	Open	VUSB to VCCM_ANA connector. The battery must be removed when this link is inserted.
M1	B	P0.6 selected for UART Tx.
M2	B	P0.7 selected For UART Rx.
M3	Open	AN_EXCITE used for thermistor operation.
M5	A	VDD_IO connection. When this link is in Position A, the VDD_IO supply is from VCCM_ANA.

EVALUATION BOARD CIRCUITRY

J-LINK OB EMULATOR

The J-Link OB emulator provides nonintrusive emulation via a serial wire and allows supply and UART communication with the ADuCM350 evaluation board (EVAL-ADuCM350EBZ). Figure 4 shows a top view of the emulator board. The J2 connector plugs into the ADuCM350 evaluation board (EVAL-ADuCM350EBZ). The J2 connector pinout is shown in Figure 5.

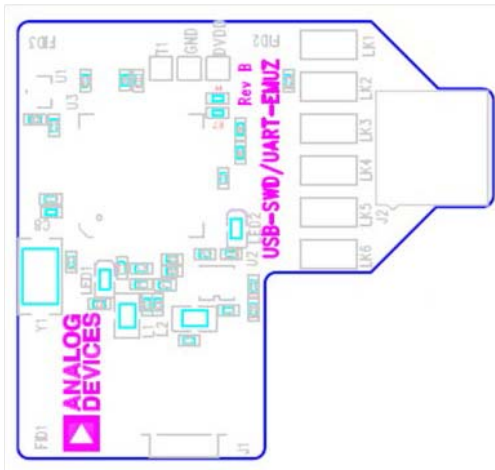
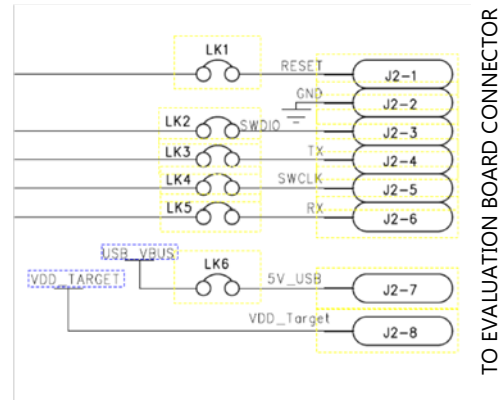

Figure 4. Emulator Top View

12104-104



TO EVALUATION BOARD CONNECTOR

12104-105

Figure 5. J2 Connector

For downloading and debugging, LK1, LK2, LK4, and LK6 must be inserted. LK3 and LK5 are required to communicate via UART. The required driver software for the J-Link OB can be downloaded from the Segger website. Ensure that you also install the virtual COM port drivers (see Figure 6).

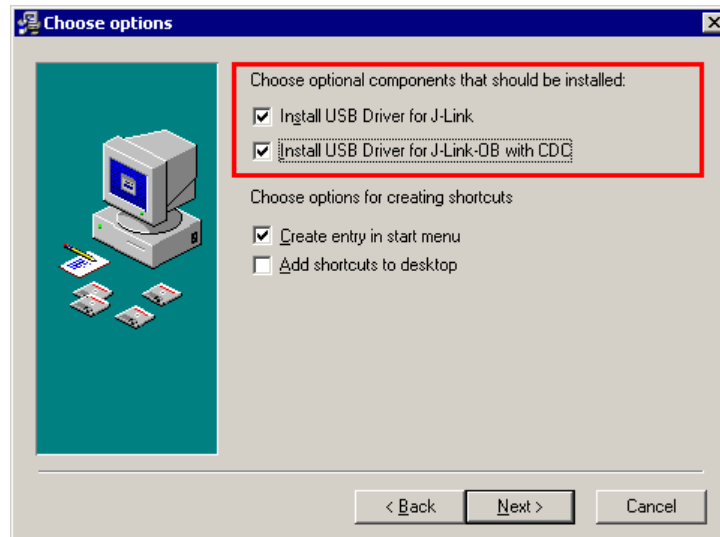

Figure 6. J-Link OB Download Options

12104-106

DIGITAL HEADER PAD LOOKUP TABLETable 5. Pinout for Digital Header 1 Pad (J20) on [EVAL-ADuCM350EBZ](#)

Top Row (from Left to Right)		Bottom Row (from Left to Right)	
Pin No.	Internal Connection	Pin No.	Internal Connection
J20-2	P2.1	J20-1	P2.0
J20-4	P2.3	J20-3	P2.2
J20-6	P2.5	J20-5	P2.4
J20-8	P1.0	J20-7	P1.1
J20-10	P1.2	J20-9	P1.3
J20-12	P1.4	J20-11	P1.5
J20-14	P1.6	J20-13	P1.7
J20-16	P3.8	J20-15	P1.9
J20-18	P3.3	J20-17	P3.9
J20-20	P1.11	J20-19	P1.8
J20-22	P1.13	J20-21	P1.10
J20-24	P1.15	J20-23	P1.12
J20-26	P2.11	J20-25	P1.14
J20-28	P2.12	J20-27	P2.10
J20-30	P2.15	J20-29	P2.9
J20-32	P3.10	J20-31	P2.8
J20-34	P2.13	J20-33	P2.7
J20-36	P3.11	J20-35	P2.6
J20-38	P3.0	J20-37	P2.14
J20-40	P3.1	J20-39	P3.2
J20-42	P3.5	J20-41	P3.4
J20-44	P3.7	J20-43	P3.6
J20-46	N/A	J20-45	N/A
J20-48	N/A	J20-47	N/A
J20-50	N/A	J20-49	N/A

Table 6. Pinout for Digital Header 2 Pad (J5) on [EVAL-ADuCM350EBZ](#)

Top Row (from Left to Right)		Bottom Row (from Left to Right)	
Pin No.	Internal Connection	Pin No.	Internal Connection
J5-19	N/A	J5-20	N/A
J5-17	N/A	J5-18	N/A
J5-15	N/A	J5-16	N/A
J5-13	N/A	J5-14	N/A
J5-11	P0.14	J5-12	P0.15
J5-9	P0.12	J5-10	P0.13
J5-7	P1.0	J5-8	P0.11
J5-5	P4.1	J5-6	P4.2
J5-3	P3.14	J5-4	P4.0
J5-1	P3.12	J5-2	P3.13

ADUCM350 MOTHERBOARD SCHEMATICS

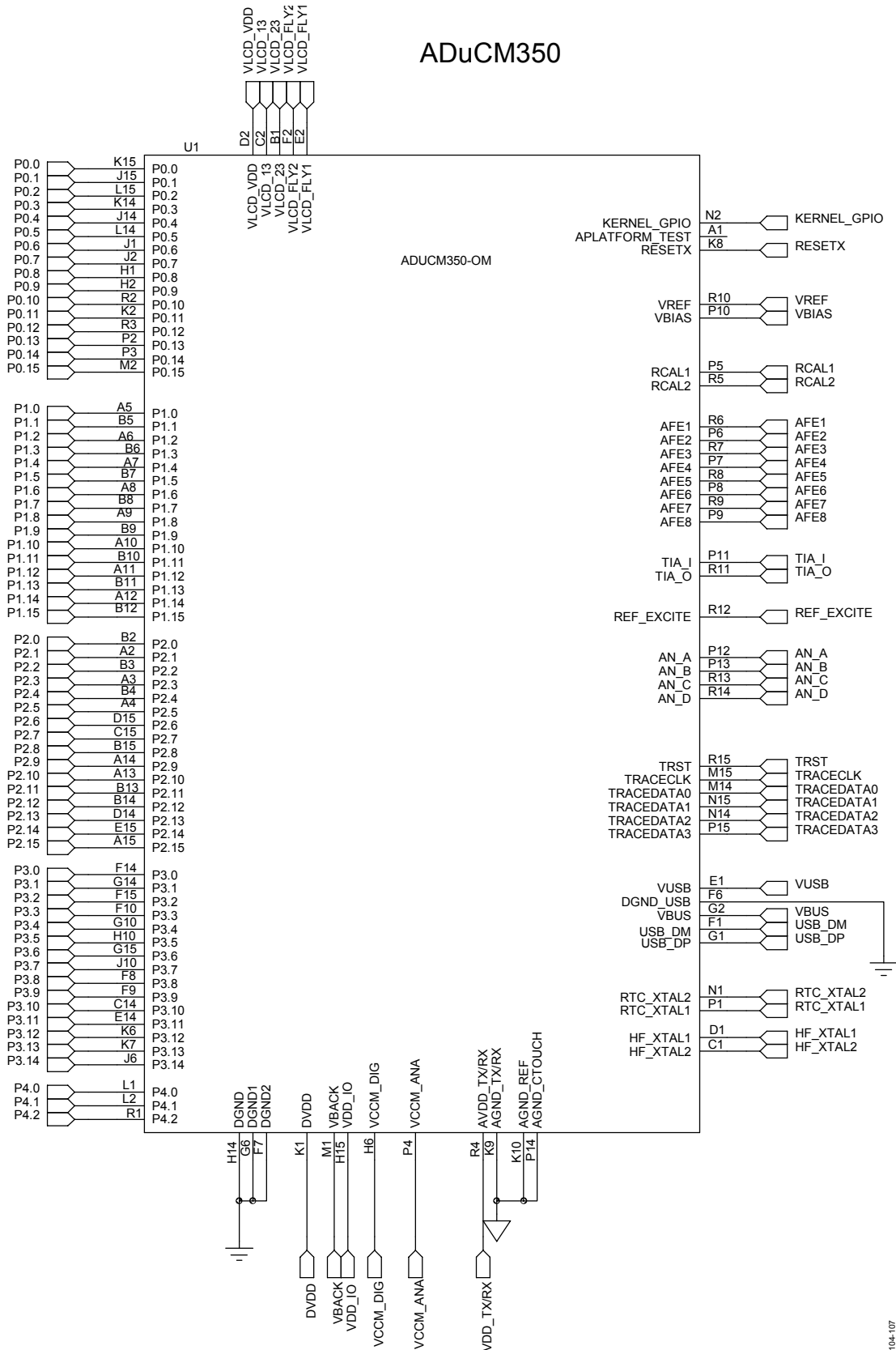
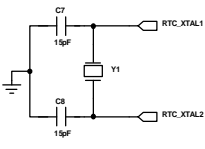

Figure 7. ADuCM350 Motherboard Schematic Device Drawing

LF 32kHz XTAL



Layout: Needs To Be Near DUT
Layout: Shielding on 16MHz

HF 16MHz XTAL

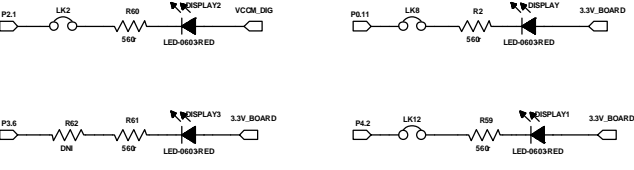
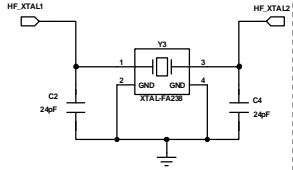

GPIO LEDs

LCD CHARGE PUMP

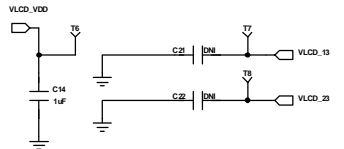
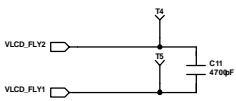

EXT INT

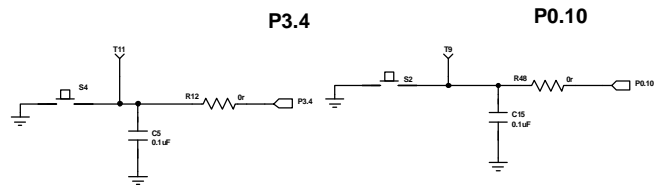

Figure 8. Digital Schematics 1

123104-108

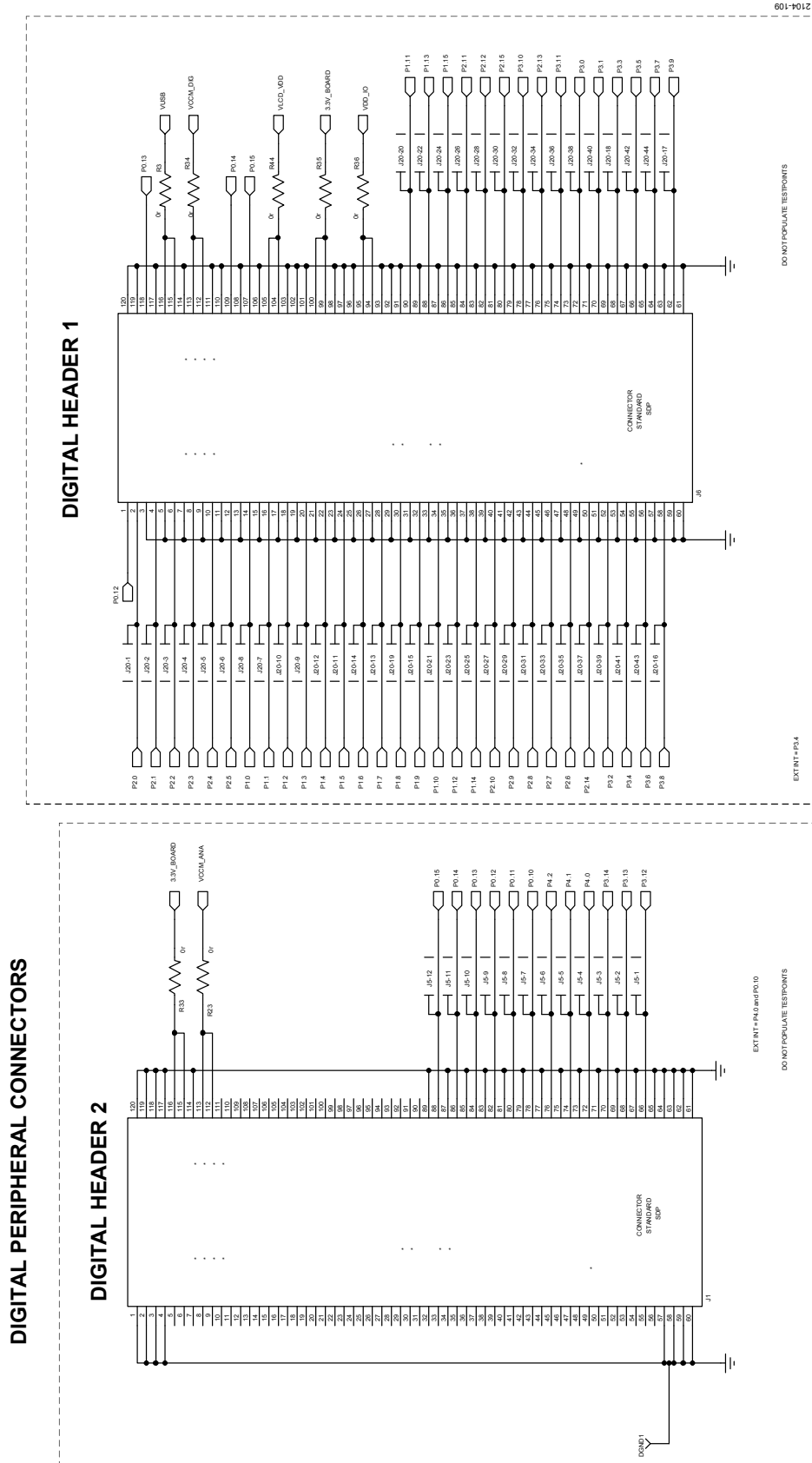
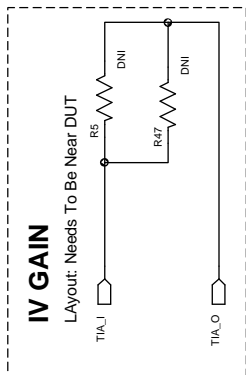
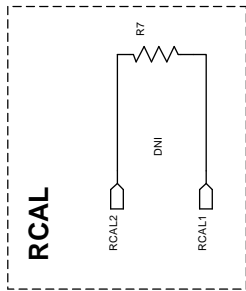

Figure 9. Digital Schematics 2



AFE DAUGHTERCARD

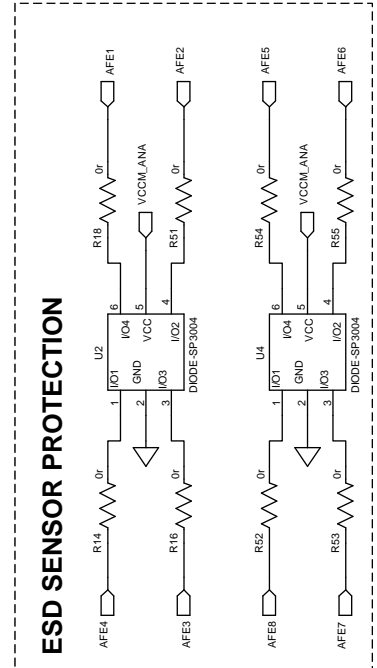
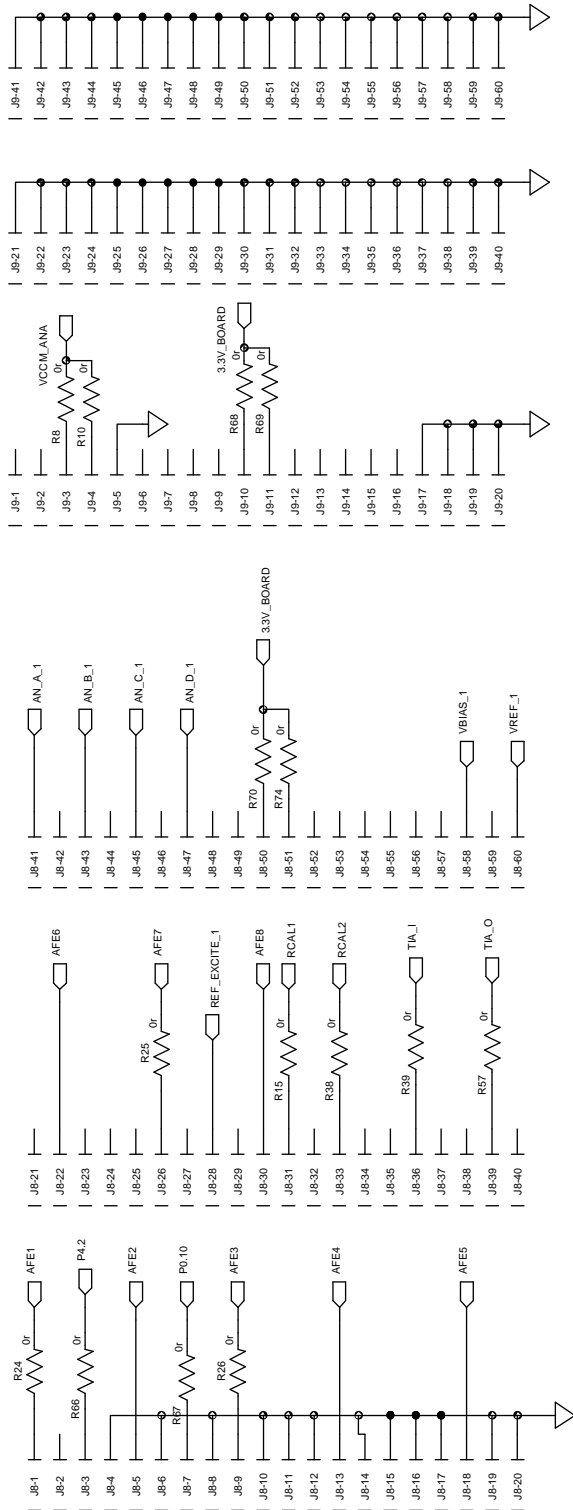

Figure 10. Analog Schematics 1

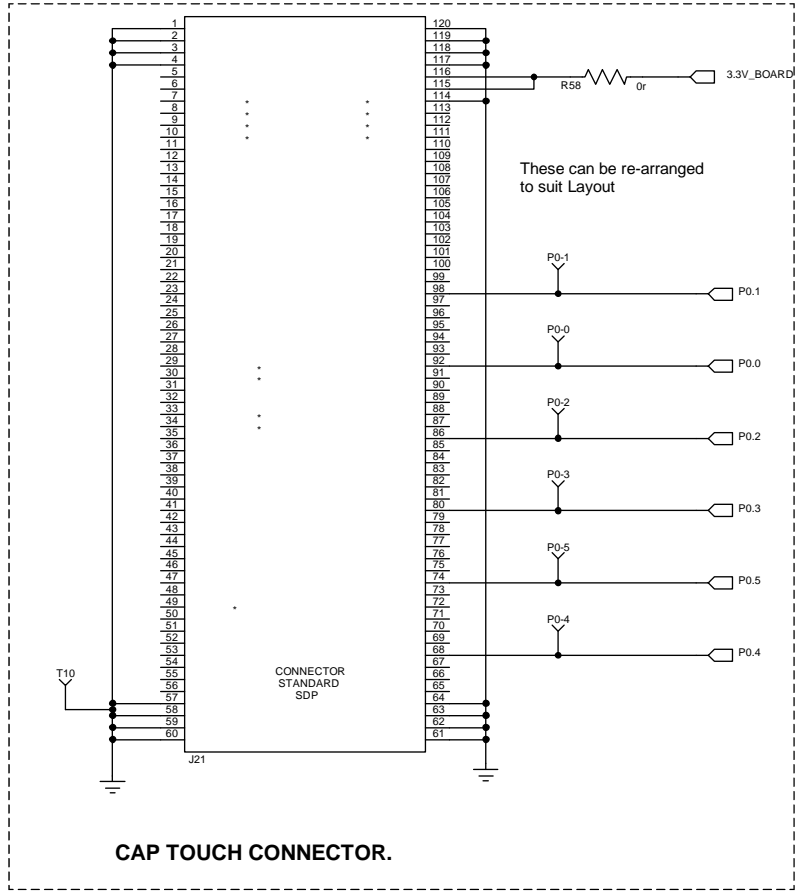
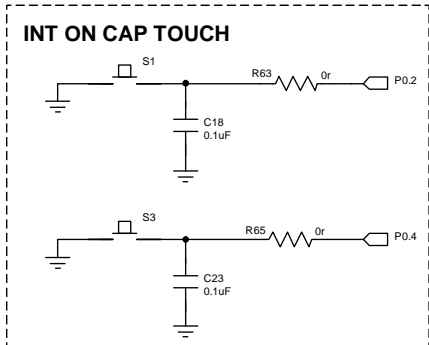
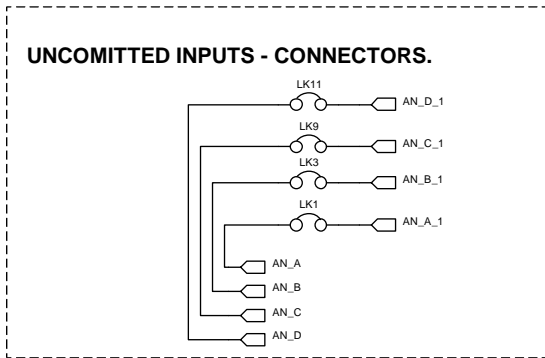
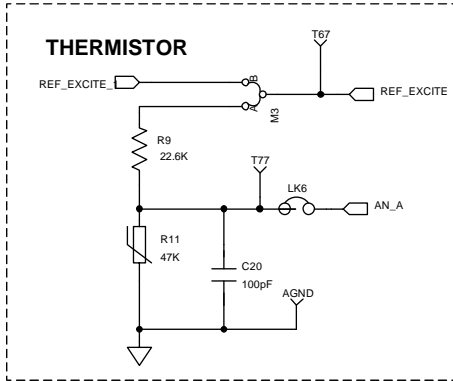

Figure 11. Analog Schematics 2

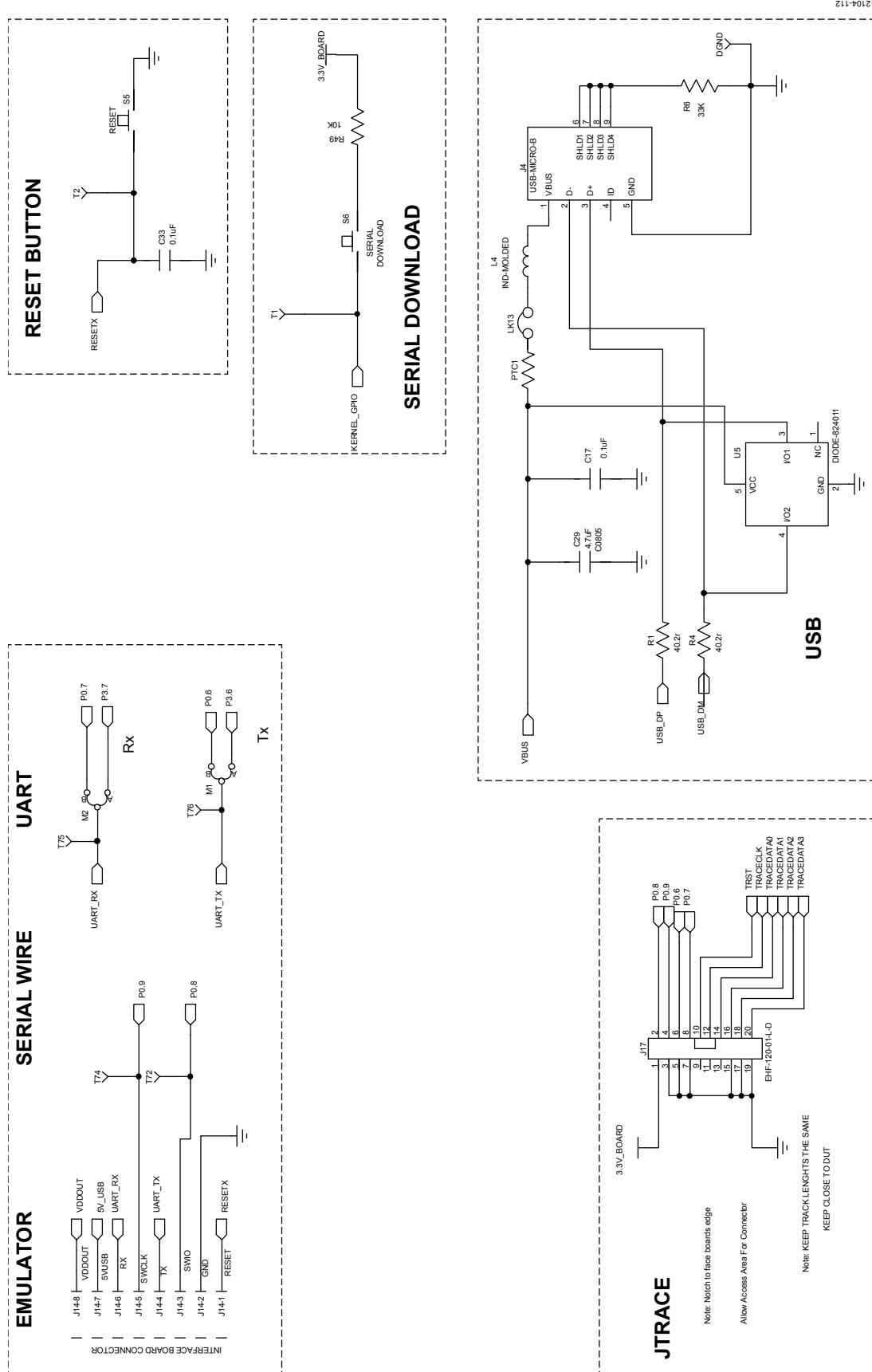
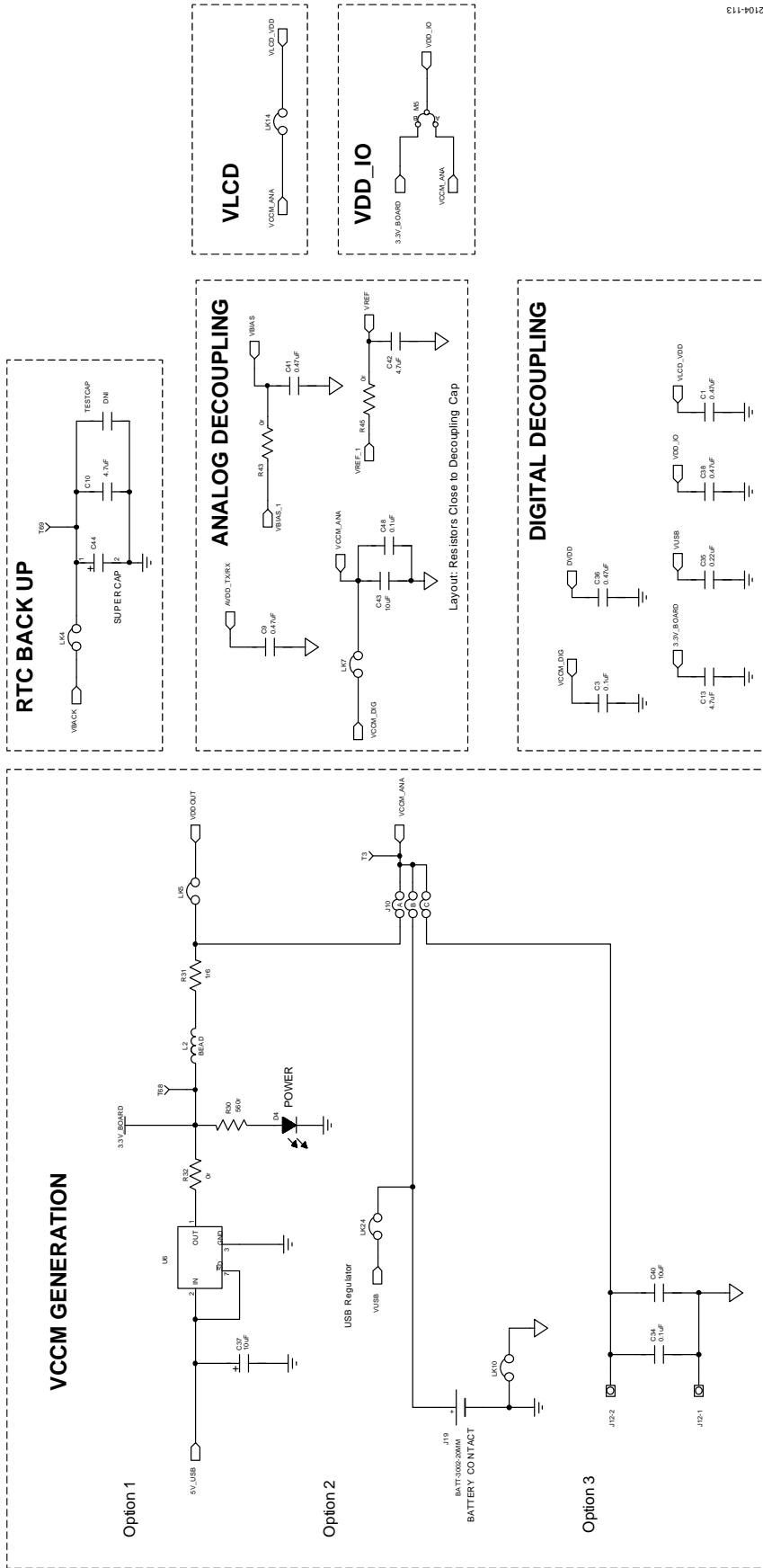

Figure 12. Interface



12104-113

Figure 13. Power
Rev. A | Page 15 of 28

ADUCM350 DAUGHTER BOARD SCHEMATICS

ADUCM350 SWITCH MUX CONFIGURATION BOARD

MOTHERBOARD CONNECTOR—ALIGN J8 AND J9.

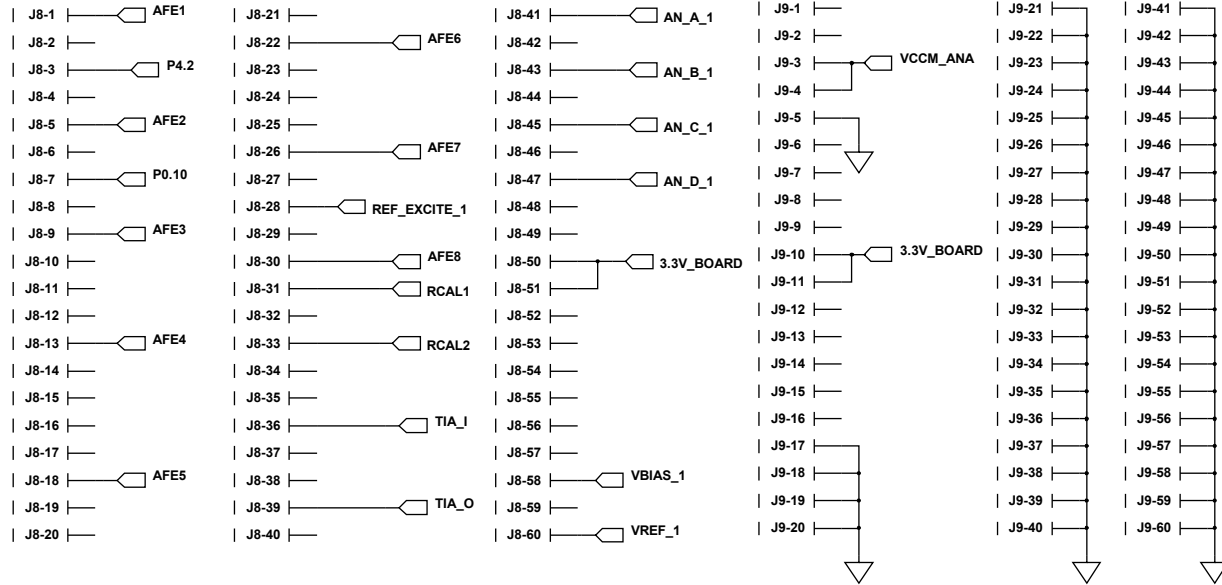
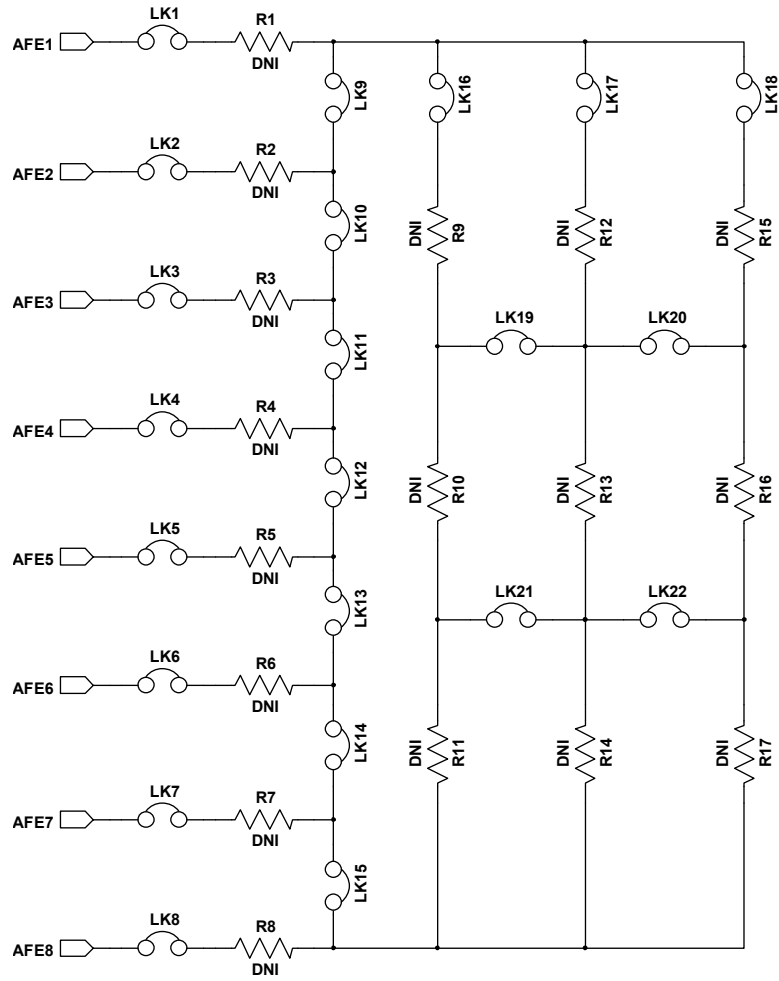

Figure 14. Switch Mux Configuration

12104-004



12104-005

Figure 15. Switch Mux Configuration—Sensor Hookup

ADUCM350 4-WIRE BIO CONFIGURATION 2 BOARD

MOTHERBOARD CONNECTOR—ALIGN J8 AND J9.

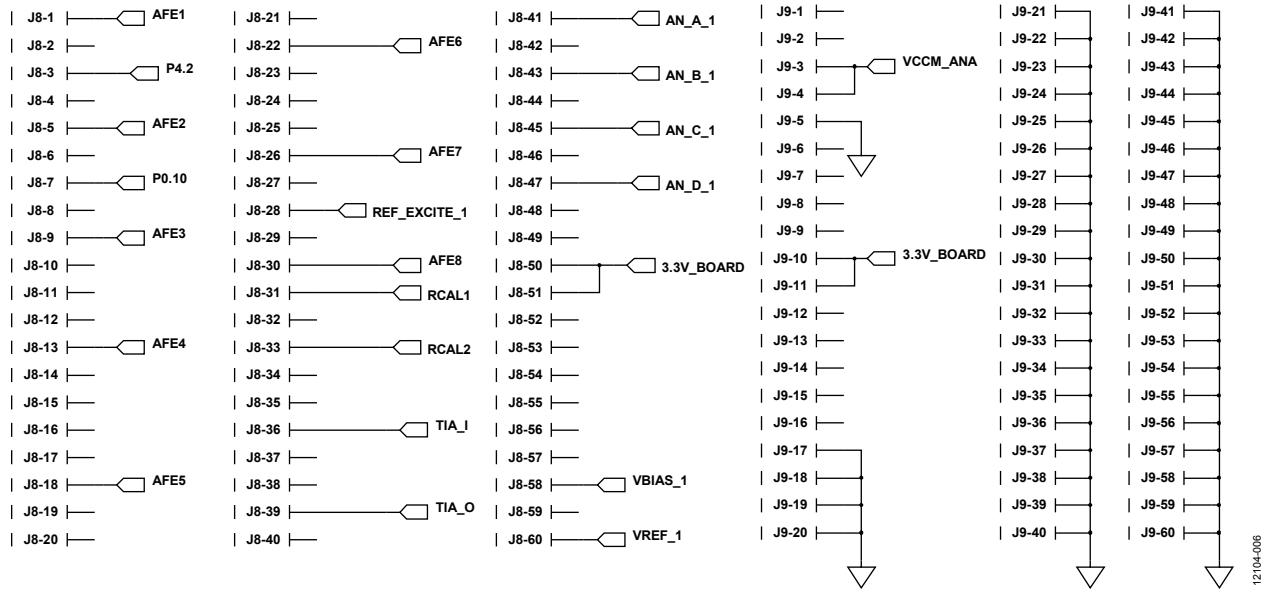

Figure 16. 4-Wire Bio Configuration Header Connections

4 WIRE BIO IMPEDANCE CONFIGURATION

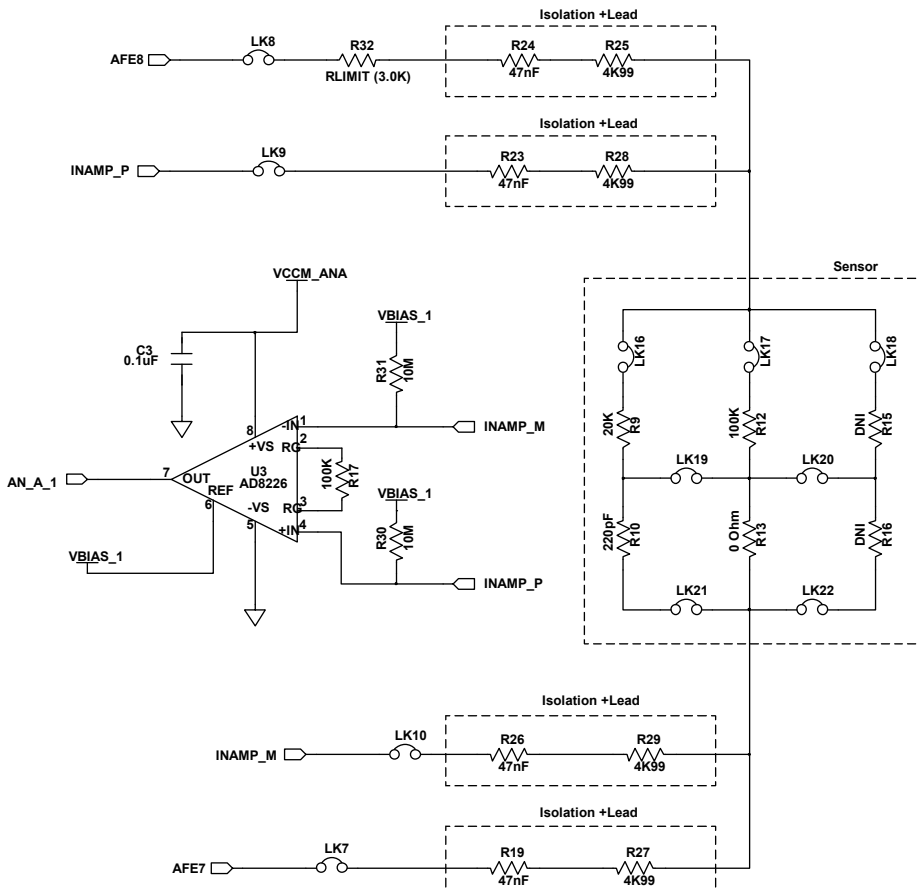
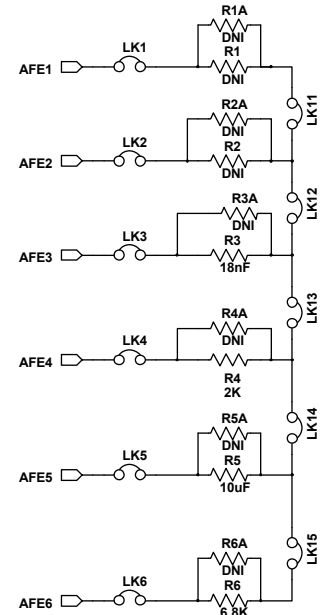

Figure 17. 4-Wire Bio Configuration Sensor Connections

UNCOMMITTED CONFIGURATION



12104-006

12104-007

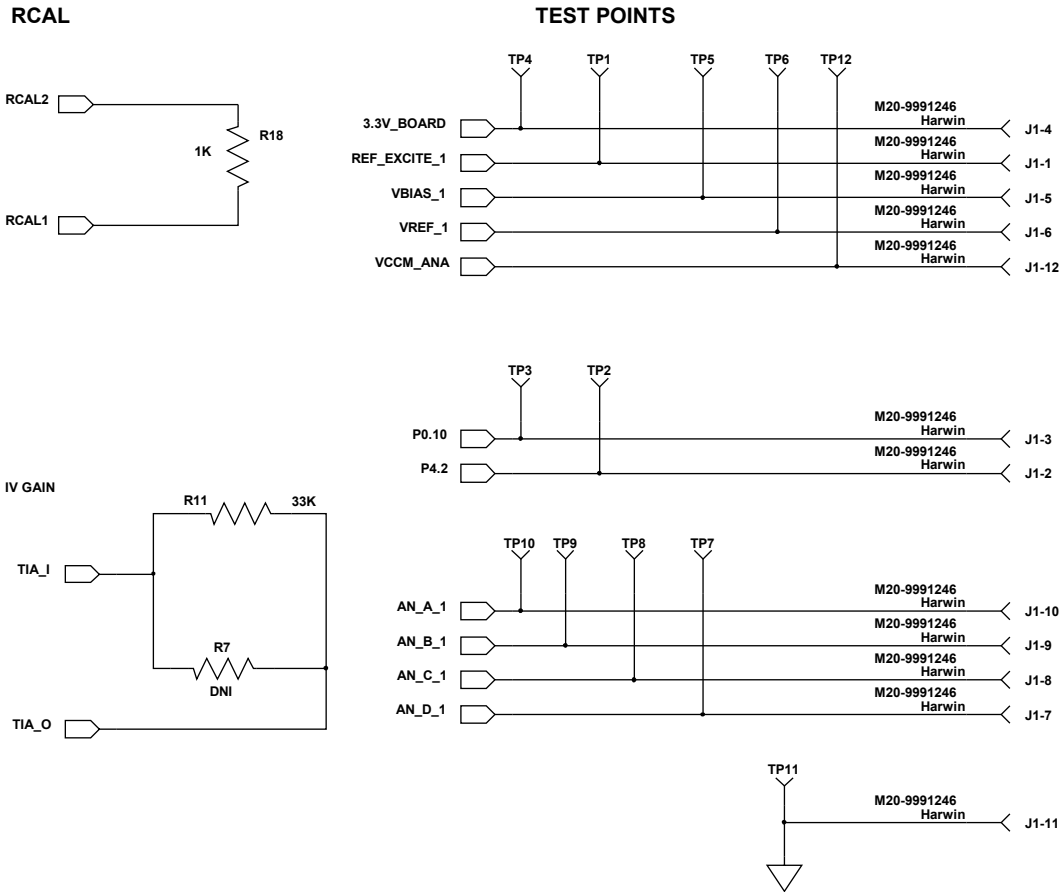

Figure 18. 4-Wire Bio Configuration Miscellaneous Connections

12104-008

AUDIO DAUGHTER BOARD REFERENCE SCHEMATICS

The Figure 19 schematic is connected to Digital Header 2 (J1) on the EVAL-ADuCM350EBZ board.

BEEPER AND I2S AMPLIFIER

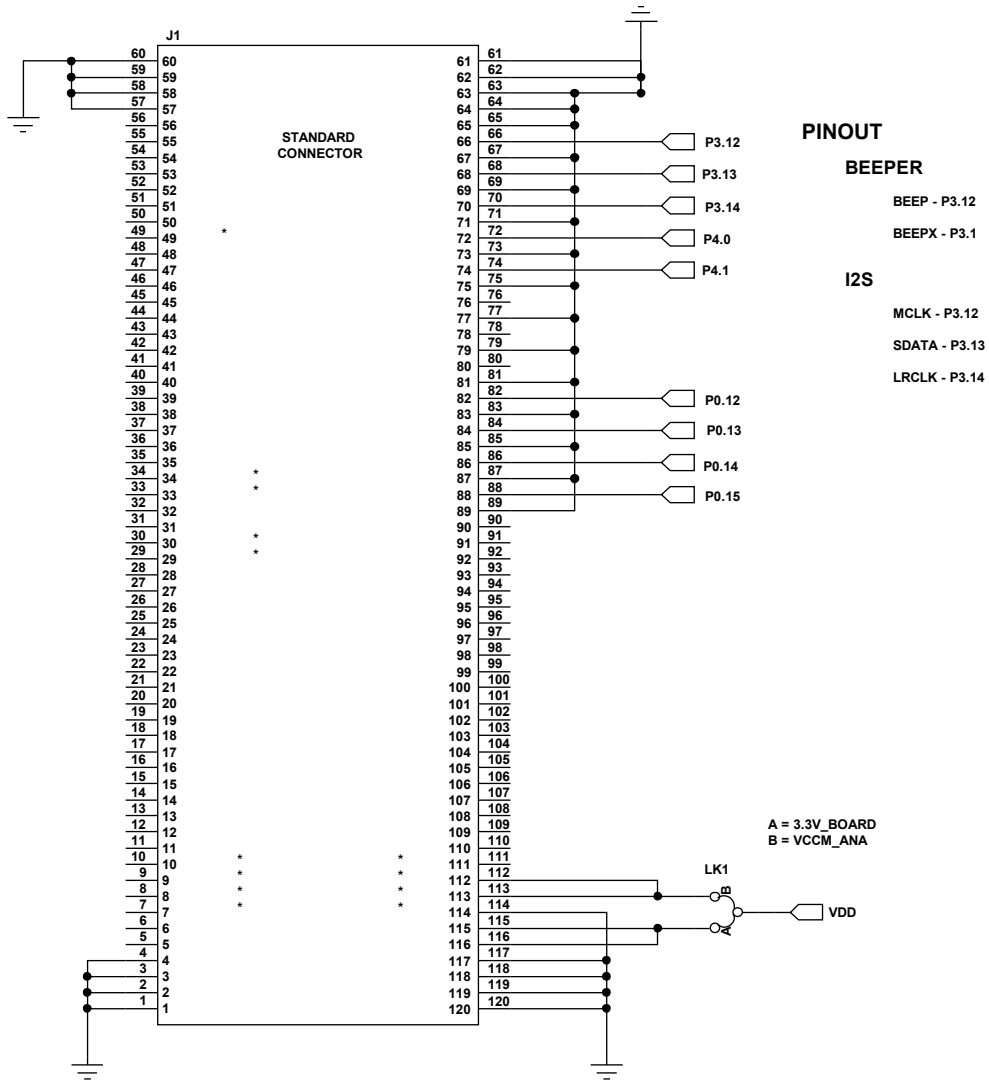

EXT INT = P4.0 and P0.10

Figure 19. Audio Schematic

12104-009

Figure 20 is a reference schematic both for the beeper/piezoelectric buzzer setup and for the I²S setup using the SSM2518.

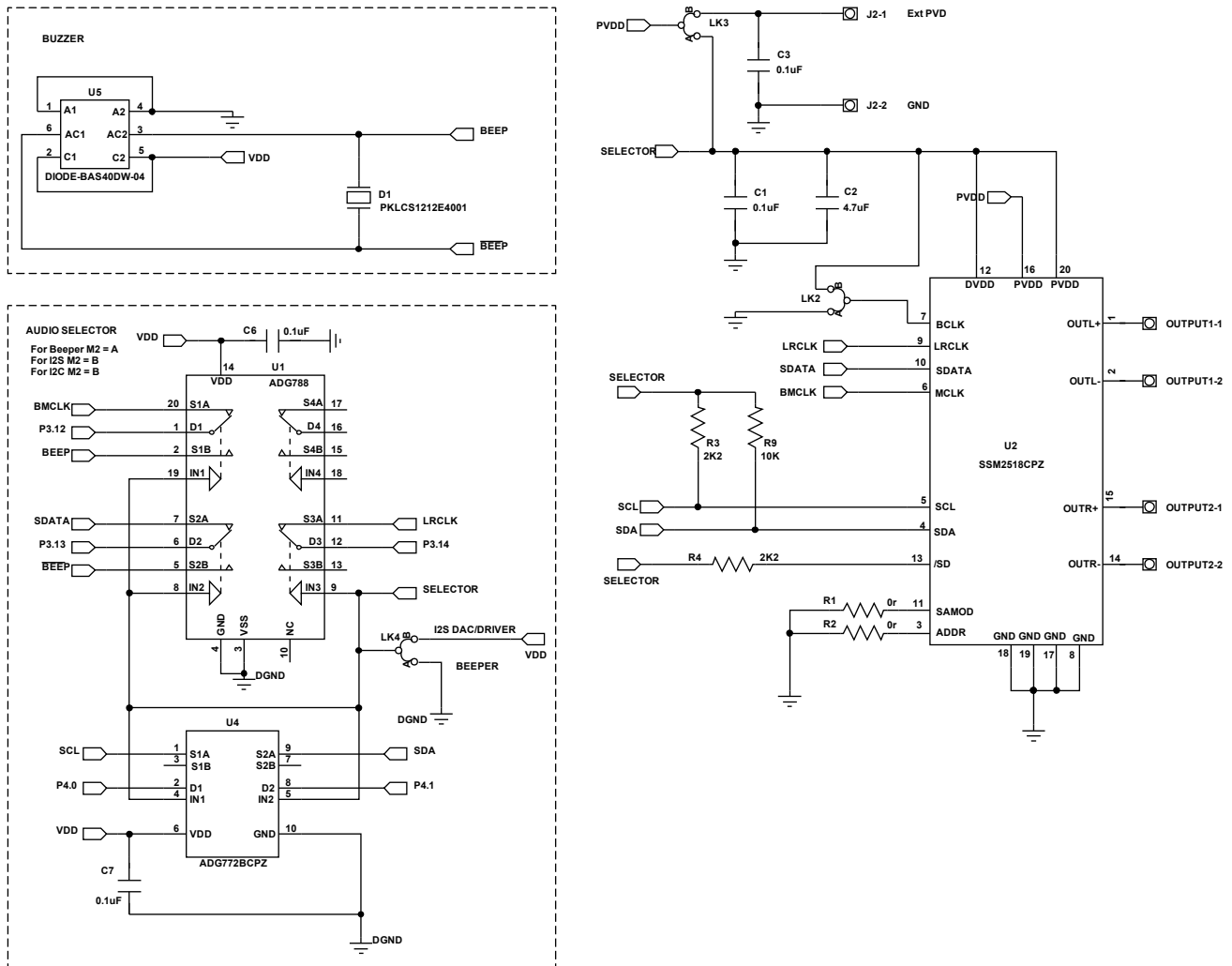

Figure 20. Audio Schematic

12104-010

DISPLAY BOARD REFERENCE SCHEMATICS

The Figure 21 schematic is the connector to Digital Header 1 (J6) on the EVAL-ADuCM350EBZ board.

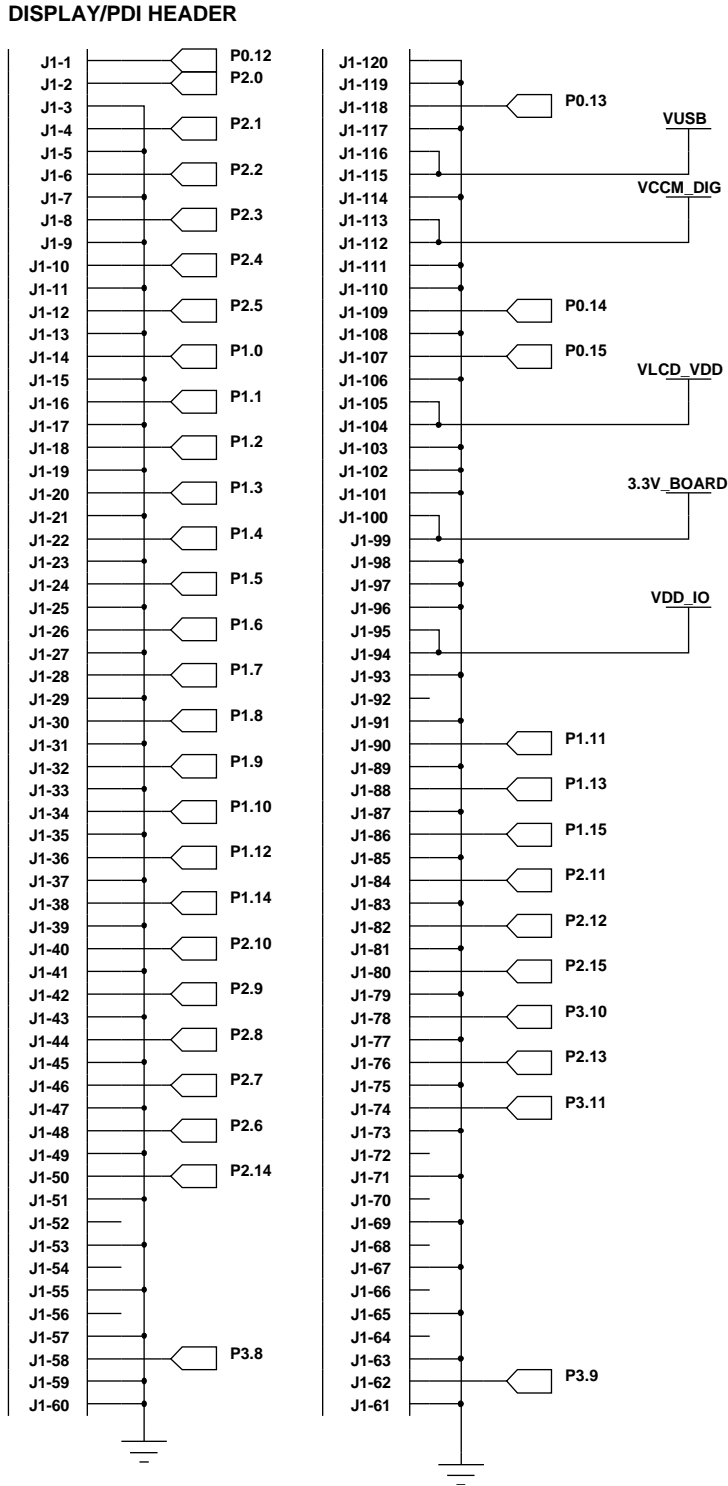

Figure 21. Display (LCD or TFT) Header Connector

12104-011

TFT Display Reference Schematic

The schematic shown in Figure 22 is used to connect to an INT035TFT or INT035TFT-TS thin film transistor LCD module from Displaytech Ltd.

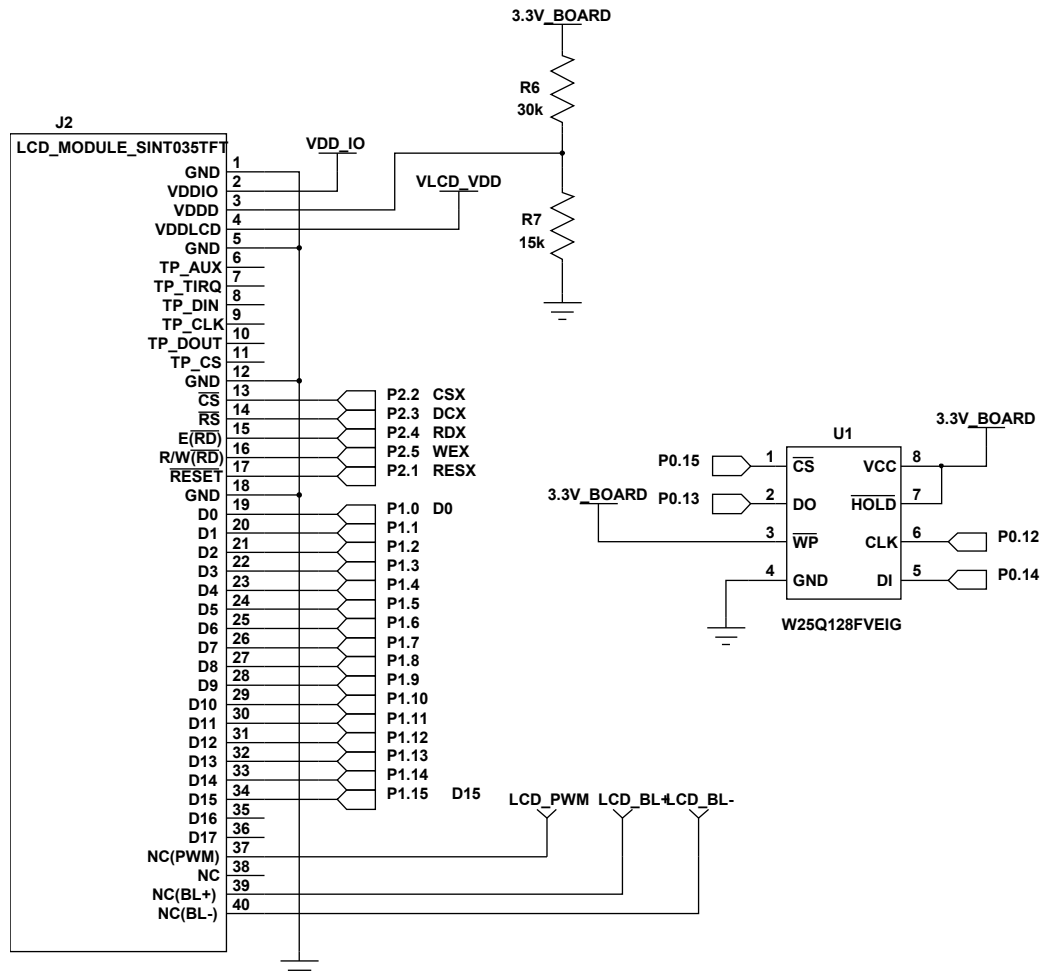

Figure 22. TFT Connector Displaytech Screen and External Flash Memory Schematic

12104-012

LCD Segment Display Reference Schematic

The schematic shown in Figure 23 is used to connect to a VIM-828 LCD segment display from Varitronix.

CONNECTOR FOR VIM-828 - TO DISCUSS

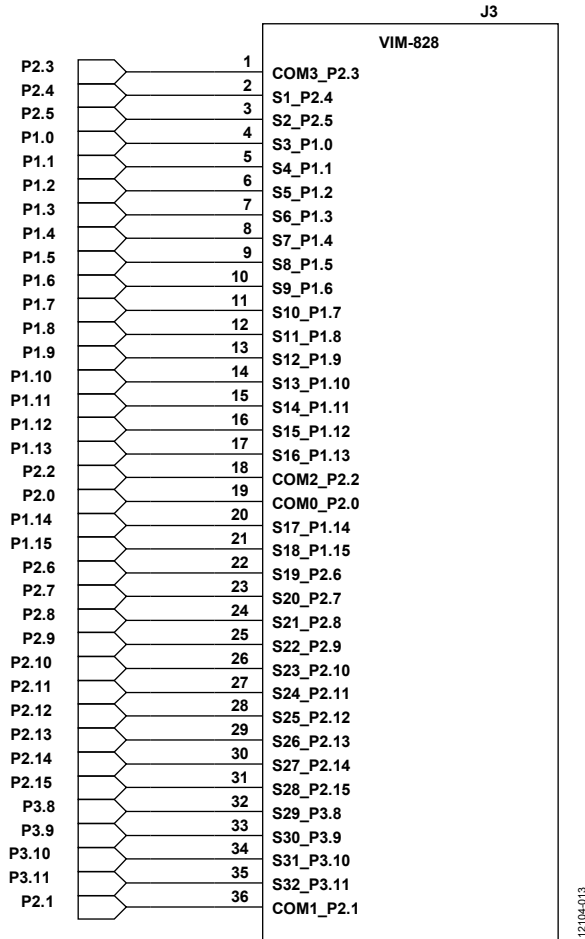

Figure 23. LCD Connector Schematic for VIM-828 LCD Segment Display

BREAKOUT BOARD PIN CONNECTIONS

If using the ADuCM350 breakout board, the connections shown in Figure 24 and Figure 25 are required.

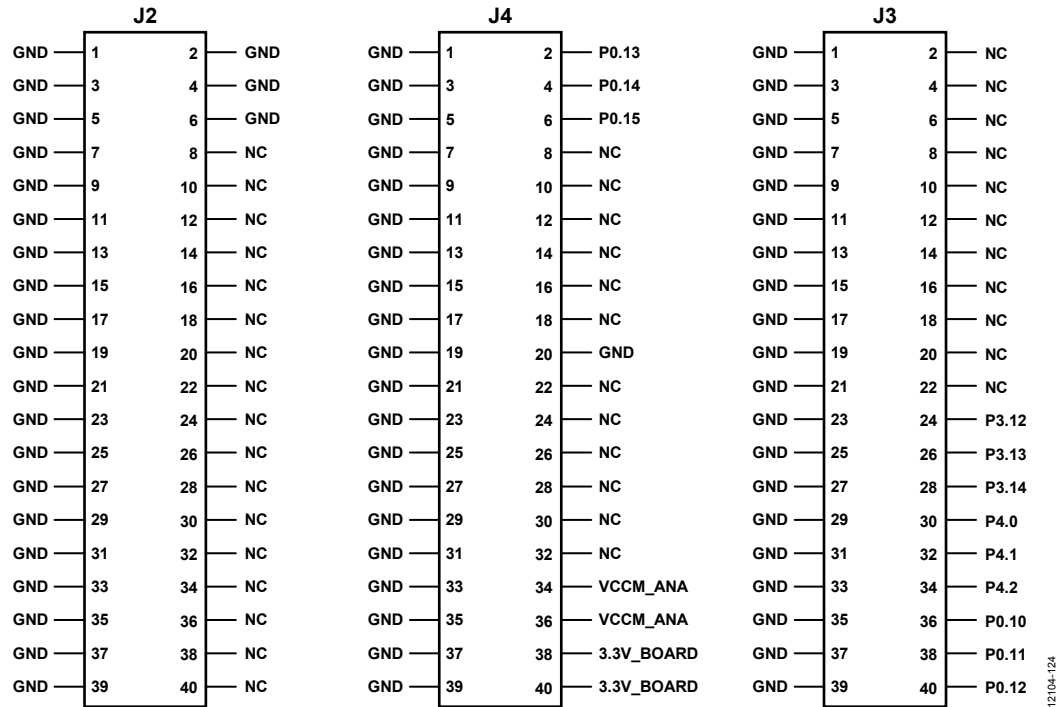

Figure 24. Breakout Board Connections for J1 on EVAL-ADuCM350EBZ with LK1 in Position B

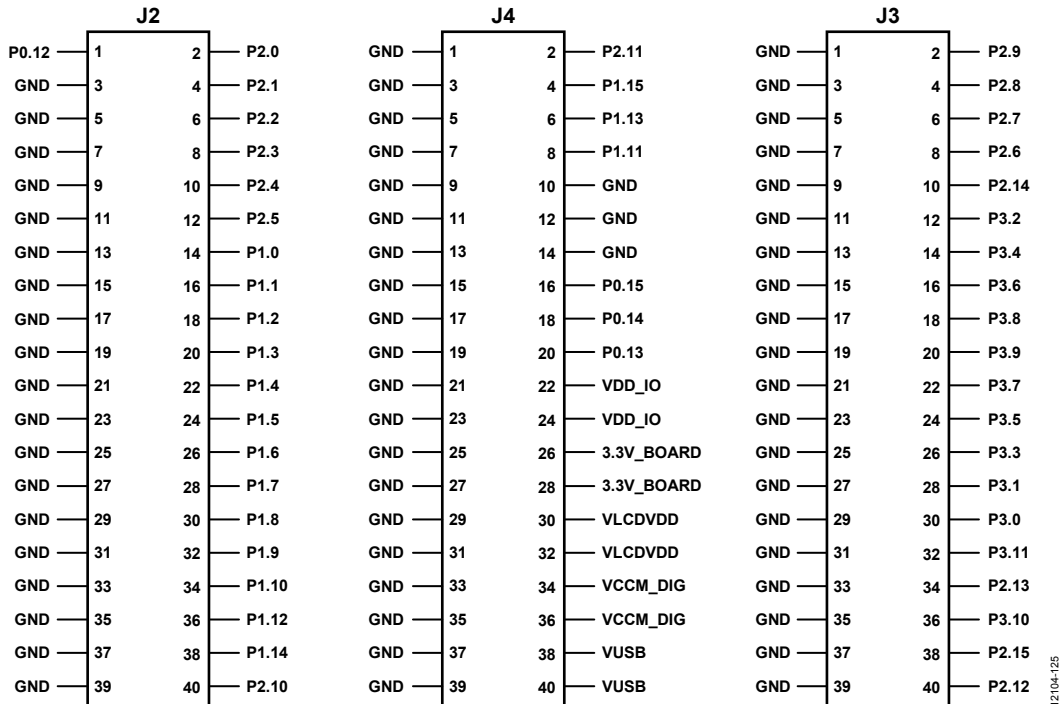

Figure 25. Breakout Board Connections for J1 on EVAL-ADuCM350EBZ with LK1 in Position A

GPIO TEST HEADER BOARD

The Figure 26 schematic is the connector to Digital Header 1 (J6) on the EVAL-ADuCM350EBZ board.

DIGITAL HEADER 1

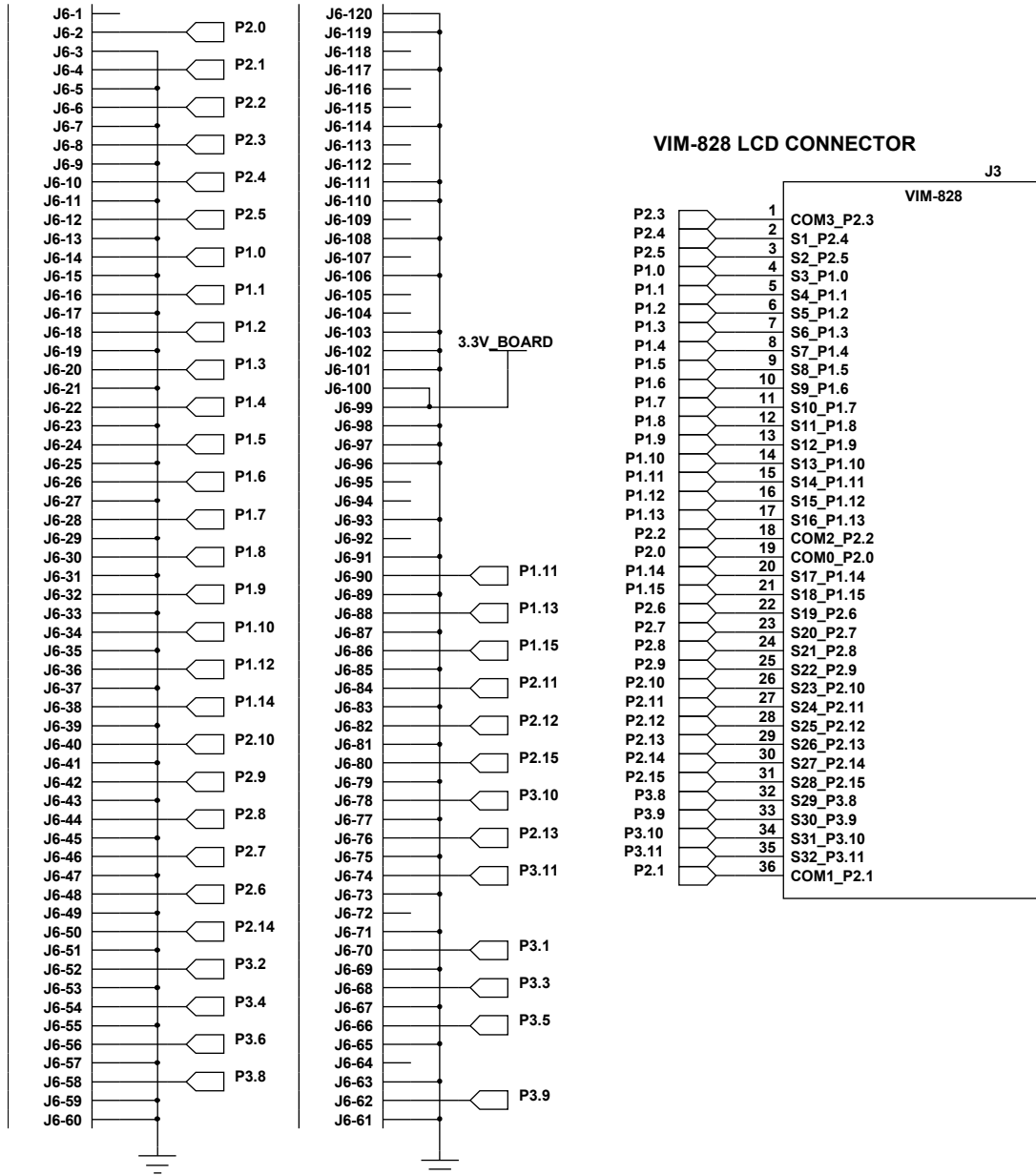

Figure 26. LCD Connector Schematic for VIM-828 LCD and Digital Header Schematic

12104-014

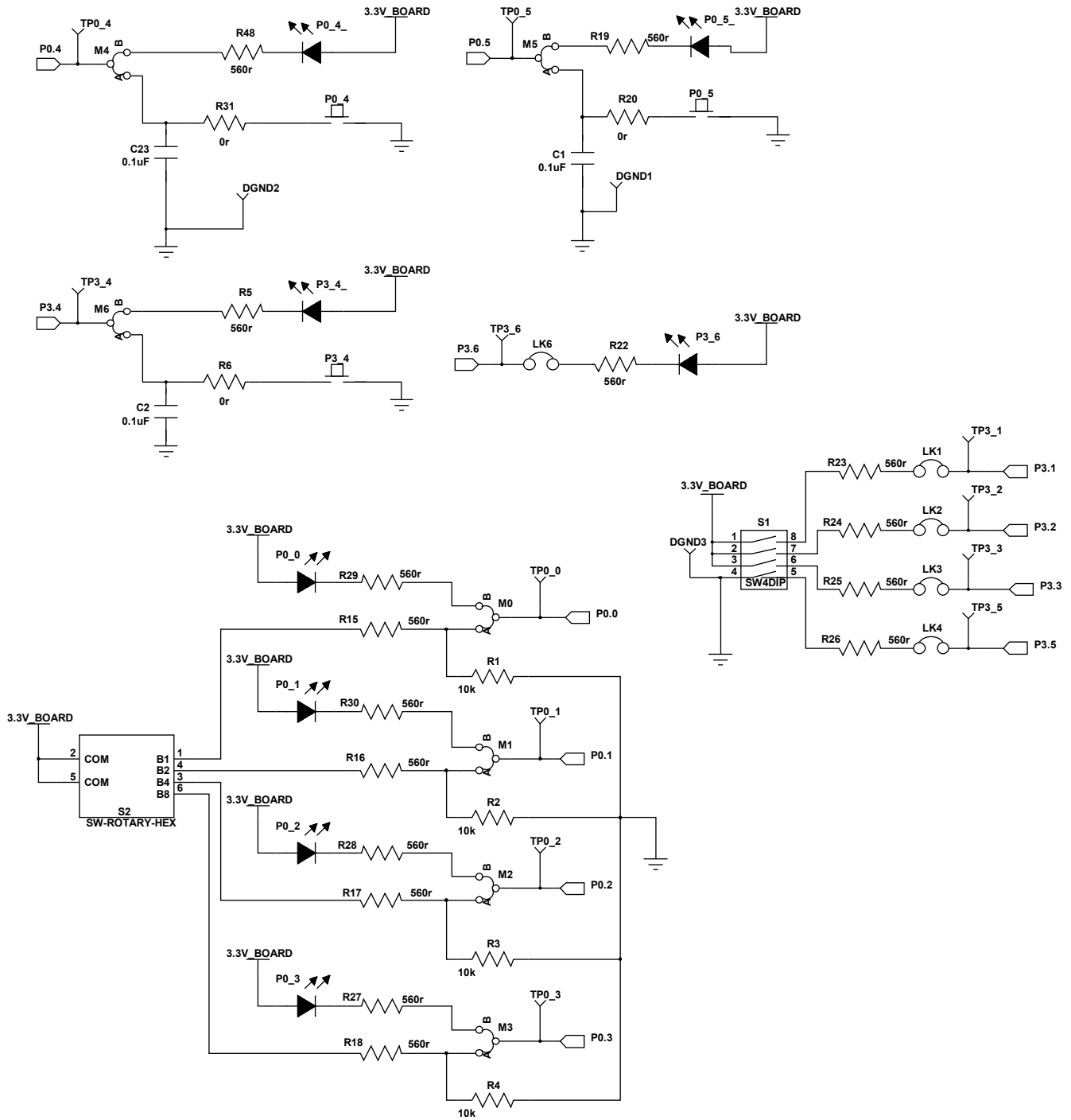

Figure 27. GPIO Evaluation Schematic

12104-015

LIMITATIONS ON USE AND LIABILITY

In addition to the terms of use contained in the evaluation board user guides, it is understood and agreed to that the evaluation board or design is not authorized for use in safety critical healthcare applications (such as life support) where malfunction or failure of a product can be expected to result in personal injury or death. This board must not be used for diagnostic purposes and must not be connected to a human being or animal. This evaluation board is provided for evaluation and development purposes only. It is not intended for use or as part of an end product. Any use of the evaluation board or design in such applications is at your own risk and you shall fully indemnify Analog Devices, Inc., its subsidiaries, employees, directors, officers, servants and agents for all liability and expenses arising from such unauthorized usage. You are solely responsible for compliance with all legal and regulatory requirements connected to such use.



ESD Caution

ESD (electrostatic discharge) sensitive device. Charged devices and circuit boards can discharge without detection. Although this product features patented or proprietary protection circuitry, damage may occur on devices subjected to high energy ESD. Therefore, proper ESD precautions should be taken to avoid performance degradation or loss of functionality.

Legal Terms and Conditions

By using the evaluation board discussed herein (together with any tools, components documentation or support materials, the "Evaluation Board"), you are agreeing to be bound by the terms and conditions set forth below ("Agreement") unless you have purchased the Evaluation Board, in which case the Analog Devices Standard Terms and Conditions of Sale shall govern. Do not use the Evaluation Board until you have read and agreed to the Agreement. Your use of the Evaluation Board shall signify your acceptance of the Agreement. This Agreement is made by and between you ("Customer") and Analog Devices, Inc. ("ADI"), with its principal place of business at One Technology Way, Norwood, MA 02062, USA. Subject to the terms and conditions of the Agreement, ADI hereby grants to Customer a free, limited, personal, temporary, non-exclusive, non-sublicensable, non-transferable license to use the Evaluation Board FOR EVALUATION PURPOSES ONLY. Customer understands and agrees that the Evaluation Board is provided for the sole and exclusive purpose referenced above, and agrees not to use the Evaluation Board for any other purpose. Furthermore, the license granted is expressly made subject to the following additional limitations: Customer shall not (i) rent, lease, display, sell, transfer, assign, sublicense, or distribute the Evaluation Board; and (ii) permit any Third Party to access the Evaluation Board. As used herein, the term "Third Party" includes any entity other than ADI, Customer, their employees, affiliates and in-house consultants. The Evaluation Board is NOT sold to Customer; all rights not expressly granted herein, including ownership of the Evaluation Board, are reserved by ADI. CONFIDENTIALITY. This Agreement and the Evaluation Board shall all be considered the confidential and proprietary information of ADI. Customer may not disclose or transfer any portion of the Evaluation Board to any other party for any reason. Upon discontinuation of use of the Evaluation Board or termination of this Agreement, Customer agrees to promptly return the Evaluation Board to ADI. ADDITIONAL RESTRICTIONS. Customer may not disassemble, decompile or reverse engineer chips on the Evaluation Board. Customer shall inform ADI of any occurred damages or any modifications or alterations it makes to the Evaluation Board, including but not limited to soldering or any other activity that affects the material content of the Evaluation Board. Modifications to the Evaluation Board must comply with applicable law, including but not limited to the RoHS Directive. TERMINATION. ADI may terminate this Agreement at any time upon giving written notice to Customer. Customer agrees to return to ADI the Evaluation Board at that time. LIMITATION OF LIABILITY. THE EVALUATION BOARD PROVIDED HEREUNDER IS PROVIDED "AS IS" AND ADI MAKES NO WARRANTIES OR REPRESENTATIONS OF ANY KIND WITH RESPECT TO IT. ADI SPECIFICALLY DISCLAIMS ANY REPRESENTATIONS, ENDORSEMENTS, GUARANTEES, OR WARRANTIES, EXPRESS OR IMPLIED, RELATED TO THE EVALUATION BOARD INCLUDING, BUT NOT LIMITED TO, THE IMPLIED WARRANTY OF MERCHANTABILITY, TITLE, FITNESS FOR A PARTICULAR PURPOSE OR NON-INFRINGEMENT OF INTELLECTUAL PROPERTY RIGHTS. IN NO EVENT WILL ADI AND ITS LICENSORS BE LIABLE FOR ANY INCIDENTAL, SPECIAL, INDIRECT, OR CONSEQUENTIAL DAMAGES RESULTING FROM CUSTOMER'S POSSESSION OR USE OF THE EVALUATION BOARD, INCLUDING BUT NOT LIMITED TO LOST PROFITS, DELAY COSTS, LABOR COSTS OR LOSS OF GOODWILL. ADI'S TOTAL LIABILITY FROM ANY AND ALL CAUSES SHALL BE LIMITED TO THE AMOUNT OF ONE HUNDRED US DOLLARS (\$100.00). EXPORT. Customer agrees that it will not directly or indirectly export the Evaluation Board to another country, and that it will comply with all applicable United States federal laws and regulations relating to exports. GOVERNING LAW. This Agreement shall be governed by and construed in accordance with the substantive laws of the Commonwealth of Massachusetts (excluding conflict of law rules). Any legal action regarding this Agreement will be heard in the state or federal courts having jurisdiction in Suffolk County, Massachusetts, and Customer hereby submits to the personal jurisdiction and venue of such courts. The United Nations Convention on Contracts for the International Sale of Goods shall not apply to this Agreement and is expressly disclaimed.

Looking for pricing, stock, or lifecycle information?

Click below to explore more details on WIN SOURCE:

- ⊖ [View EVAL-ADUCM350EBZ on WIN SOURCE](#)
- ⊖ [Analog Devices Inc. Information](#)

Optimize Your Supply Chain with WIN SOURCE Solutions

- ✓ Global Sourcing Solution
- ✓ Obsolete Management
- ✓ Cost Control Management
- ✓ Shortage Management
- ✓ Alternative Solution
- ✓ Excess Inventory Management