



**THE DATASHEET OF  
EP1M120F484I6**





# Mercury

## Programmable Logic Device Family

January 2003, ver. 2.2

Data Sheet

### Features...

- High-performance programmable logic device (PLD) family (see [Table 1](#))
  - Integrated high-speed transceivers with support for clock data recovery (CDR) at up to 1.25 gigabits per second (Gbps)
  - Look-up table (LUT)-based architecture optimized for high speed
  - Advanced interconnect structure for fast routing of critical paths
  - Enhanced I/O structure for versatile standards and interface support
  - Up to 14,400 logic elements (LEs)
- System-level features
  - Up to four general-purpose phase-locked loops (PLLs) with programmable multiplication and delay shifting
  - Up to 12 PLL output ports
  - Dedicated multiplier circuitry for high-speed implementation of signed or unsigned multiplication up to  $16 \times 16$
  - Embedded system blocks (ESBs) used to implement memory functions including quad-port RAM, true dual-port RAM, first-in first-out (FIFO) buffers, and content-addressable memory (CAM)
  - Each ESB contains 4,096 bits and can be split and used as two 2,048-bit unidirectional dual-port RAM blocks

Feature	EP1M120	EP1M350
Typical gates	120,000	350,000
HSDI channels	8	18
LEs	4,800	14,400
ESBs (1)	12	28
Maximum RAM bits	49,152	114,688
Maximum user I/O pins	303	486

**Note to Table 1:**

(1) Each ESB can be used for two dual- or single-port RAM blocks.

## ...and More Features

- Advanced high-speed I/O features
  - Robust I/O standard support, including LVTTTL, PCI up to 66 MHz, 3.3-V AGP in 1× and 2× modes, 3.3-V SSTL-3 and 2.5-V SSTL-2, GTL+, HSTL, CTT, LVDS, LVPECL, and 3.3-V PCML
  - High-speed differential interface (HSDI) with dedicated circuitry for CDR at up to 1.25 Gbps for LVDS, LVPECL, and 3.3-V PCML
  - Support for source-synchronous True-LVDS™ circuitry up to 840 megabits per second (Mbps) for LVDS, LVPECL, and 3.3-V PCML
  - Up to 18 input and 18 output dedicated differential channels of high-speed LVDS, LVPECL, or 3.3-V PCML
  - Built-in 100-Ω termination resistor on HSDI data and clock differential pairs
  - Flexible-LVDS™ circuitry provides 624-Mbps support on up to 100 channels with the EP1M350 device
  - Versatile three-register I/O element (IOE) supporting double data rate I/O (DDRIO), double data-rate (DDR) SDRAM, zero bus turnaround (ZBT) SRAM, and quad data rate (QDR) SRAM
- Designed for low-power operation
  - 1.8-V internal supply voltage ( $V_{CCINT}$ )
  - MultiVolt™ I/O interface voltage levels ( $V_{CCIO}$ ) compatible with 1.5-V, 1.8-V, 2.5-V, and 3.3-V devices
  - 5.0-V tolerant with external resistor
- Advanced interconnect structure
  - Multi-level FastTrack® Interconnect structure providing fast, predictable interconnect delays
  - Optimized high-speed Priority FastTrack Interconnect for routing critical paths in a design
  - Dedicated carry chain that implements arithmetic functions such as fast adders, counters, and comparators (automatically used by software tools and megafunctions)
  - FastLUT™ connection allowing high speed direct connection between LEs in the same logic array block (LAB)
  - Leap lines allowing a single LAB to directly drive LEs in adjacent rows
  - The RapidLAB interconnect providing a high-speed connection to a 10-LAB-wide region
  - Dedicated clock and control signal resources, including four dedicated clocks, six dedicated fast global signals, and additional row-global signals

Tables 2 and 3 show the Mercury™ FineLine BGA™ device package sizes, options, and I/O pin counts.

Feature	484-Pin FineLine BGA	780-Pin FineLine BGA
Pitch (mm)	1.00	1.00
Area (mm <sup>2</sup> )	529	841
Length × width (mm × mm)	23 × 23	29 × 29

Device	484-Pin FineLine BGA	780-Pin FineLine BGA
EP1M120	303	
EP1M350		486

## General Description

Mercury devices integrate high-speed differential transceivers and support for CDR with a speed-optimized PLD architecture. These transceivers are implemented through the dedicated serializer, deserializer, and clock recovery circuitry in the HSDI and incorporate support for the LVDS, LVPECL, and 3.3-V PCML I/O standards. This circuitry, together with enhanced I/O elements (IOEs) and support for numerous I/O standards, allows Mercury devices to meet high-speed interface requirements.

Mercury devices are the first PLDs optimized for core performance. These LUT-based, enhanced memory devices use a network of fast routing resources to achieve optimal performance. These resources are ideal for data-path, register-intensive, mathematical, digital signal processing (DSP), or communications designs.

Mercury devices include other features for performance such as quad-port RAM, CAM, general purpose PLLs, and dedicated circuitry for implementing multiplier circuits. [Table 4](#) shows Mercury performance.

Application	Resources Used		Performance			
	LEs	ESBs	-5 Speed Grade	-6 Speed Grade	-7 Speed Grade	Units
16-bit loadable counter (1)	16	0	400	400	400	MHz
32-bit loadable counter (1)	32	0	400	400	400	MHz
32-bit accumulator (1)	32	0	400	400	400	MHz
32-to-1 multiplexer	27	0	1.864	2.466	2.723	ns
32 × 64 asynchronous FIFO	103	2	290	258	242	MHz
8-bit, 37-tap FIR filter	251	1	290	240	205	MSPS

**Note to Table 4:**

- (1) The clock tree supports up to 400 MHz. Although the registered performance for these designs exceed 400 MHz, they are limited by the clock tree limit.

### Configuration

The logic, circuitry, and interconnects in the Mercury architecture are configured with CMOS SRAM elements. Mercury devices are reconfigurable and are 100% tested prior to shipment. As a result, test vectors do not have to be generated for fault coverage purposes. Instead, the designer can focus on simulation and design verification. In addition, the designer does not need to manage inventories of different ASIC designs; Mercury devices can be configured on the board for the specific functionality required.

Mercury devices are configured at system power-up with data stored in an Altera® serial configuration device or provided by a system controller. Altera offers in-system programmability (ISP)-capable configuration devices, which configure Mercury devices via a serial data stream. Mercury devices can be configured in under 70 ms. Moreover, Mercury devices contain an optimized interface that permits microprocessors to configure Mercury devices serially or in parallel, synchronously or asynchronously. This interface also enables microprocessors to treat Mercury devices as memory and to configure the device by writing to a virtual memory location, simplifying reconfiguration.

After a Mercury device has been configured, it can be reconfigured in-circuit by resetting the device and loading new data. Real-time changes can be made during system operation, enabling innovative reconfigurable computing applications.

## Software

Mercury devices are supported by the Altera Quartus™ II development system, a single, integrated package that offers HDL and schematic design entry, compilation and logic synthesis, full simulation and worst-case timing analysis, SignalTap™ logic analysis, and device configuration. The Quartus II software also ships with Altera-specific HDL synthesis tools from Exemplar Logic and Synopsys, and Altera-specific Register Transfer Level (RTL) and timing simulation tools from Model Technology. The Quartus II software supports PCs running Windows 98, Windows NT 4.0, and Windows 2000; UNIX workstations running Solaris 2.6, 7, or 8, or HP-UX 10.2 or 11.0; and PCs running Red Hat Linux 7.1.

The Quartus II software provides NativeLink™ interfaces to other industry-standard PC- and UNIX-workstation-based EDA tools. For example, designers can invoke the Quartus II software from within the Mentor Graphics LeonardoSpectrum software, Synplicity's Synplify software, and the Synopsys FPGA *Express* software. The Quartus II software also contains built-in optimized synthesis libraries; synthesis tools can use these libraries to optimize designs for Mercury devices. For example, the Synopsys Design Compiler library, supplied with the Quartus II development system, includes DesignWare functions optimized for the Mercury architecture.

For more information on the Quartus II development system, see the *Quartus II Programmable Logic Development System & Software Data Sheet*.

## Functional Description

The Mercury architecture contains a row-based logic array to implement general logic and a row-based embedded system array to implement memory and specialized logic functions. Signal interconnections within Mercury devices are provided by a series of row and column interconnects with varying lengths and speeds. The priority FastTrack Interconnect structure is faster than other interconnects; the Quartus II Compiler places design-critical paths on these faster lines to improve design performance.

Mercury device I/O pins are evenly distributed across the entire device area; other Altera device families have I/O pins placed on the device periphery. Mercury device I/O pin placement allows for higher I/O count at a given die size; pad size is no longer a limiting issue. Each I/O pin is fed by an IOE. IOEs are grouped in IOE row bands from the top to the bottom of the device. IOE row bands are separated by several LAB rows. LABs from the associated LAB row closest to the I/O row band drive IOEs through the local interconnect. This feature allows fast clock-to-output times when a pin is driven by any of the 10 LEs in the adjacent associated LAB. Each IOE contains a bidirectional buffer along with an input register, output register, output enable (OE) register, and input latch for DDR. When used with a global clock, these dedicated registers provide exceptional bidirectional I/O performance.

IOEs provide a variety of features, such as 3.3-V, 64-bit, 66-MHz PCI compliance; 3.3-V, 64-bit, 133-MHz PCI-X compliance; Joint Test Action Group (JTAG) boundary-scan test (BST) support; output drive strength control; slew-rate control; tri-state buffers; bus-hold circuitry; programmable pull-up resistors; programmable input and output delays; and open-drain outputs. Mercury devices offer enhanced I/O support, including support for 1.8-V I/O, 2.5-V I/O, LVCMOS, LVTTTL, HSTL, LVPECL, 3.3-V PCML, 3.3-V PCI, PCI-X, LVDS, GTL+, SSTL-2, SSTL-3, CTT, and 3.3-V AGP I/O standards. CDR (up to 1.25 Gbps) and source-synchronous (up to 840 Mbps) transfers are supported with HSDI circuitry for LVDS, LVPECL, and 3.3-V PCML I/O standards.

The ESB can implement a variety of memory functions, including CAM, quad-port RAM, true dual-port RAM, dual- and single-port RAM, ROM, and FIFO functions. ESBs are grouped into two rows: one at the top and one at the bottom of the device. Embedding the memory directly into the die improves performance and reduces die area compared to distributed-RAM implementations. Moreover, the abundance of cascadable ESBs, in conjunction with the ability for one ESB to implement two separate memory blocks, ensures that the Mercury device can implement multiple wide memory blocks for high-density designs. The ESB's high speed ensures the implementation of small memory blocks without any speed penalty. The abundance of ESBs ensures that designers can create as many different-sized memory blocks as the system requires. [Figure 1](#) shows an overview of the Mercury device.

Figure 1. Mercury Architecture Block Diagram *Note (1)*

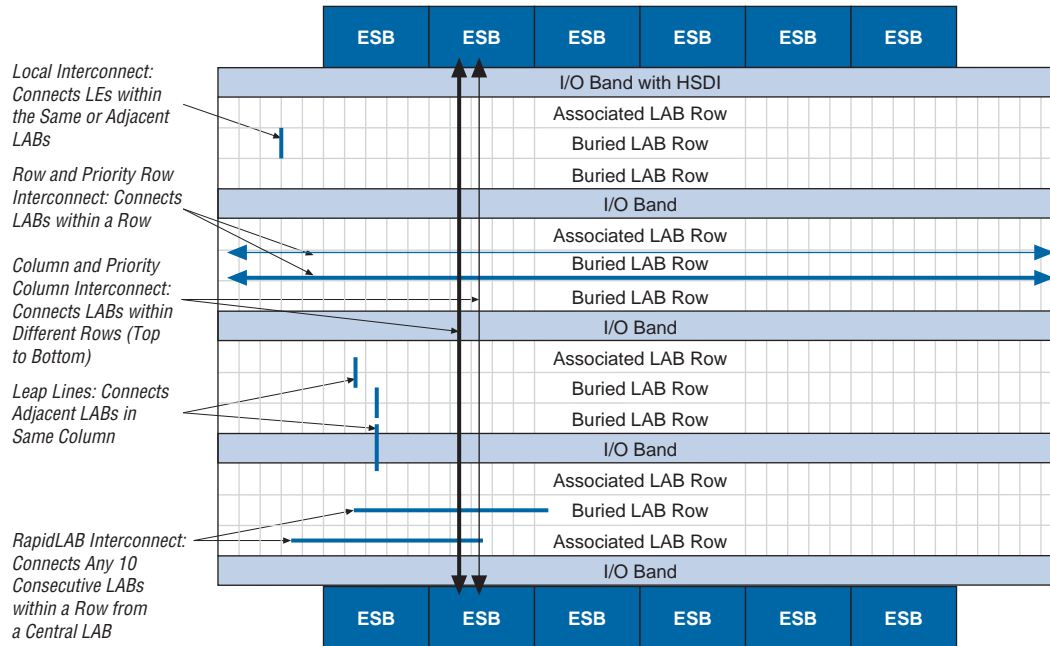

**Note to Figure 1:**

(1) Figure 1 shows an EP1M120 device. Mercury devices have a varying number of rows, columns, and ESBs, as shown in Table 5.

Table 5 lists the resources available in Mercury devices.

Table 5. Mercury Device Resources				
Device	LAB Rows	LAB Columns	I/O Row Bands	ESBs
EP1M120	12	40	5	12
EP1M350	18	80	4	28

## High-Speed Differential Interface

Mercury devices provide four dedicated clock input pins and six dedicated fast I/O pins that globally drive register control inputs, including clocks. These signals ensure efficient distribution of high-speed, low-skew control signals. The control signals use dedicated routing channels to provide short delays and low skew. The dedicated fast signals can also be driven by internal logic, providing an ideal solution for a clock divider or internally generated asynchronous control signal with high fan-out. The dedicated clock and fast I/O pins on Mercury devices can also feed logic. Dedicated clocks can also be used with the Mercury general purpose PLLs for clock management.

Each I/O row band also provides two additional I/O pins that can drive two row-global signals. Row-global signals can drive register control inputs for the LAB row associated with that particular I/O row band.

The top I/O or HSDI band in Mercury devices contains dedicated circuitry for supporting differential standards at speeds up to 1.25 Gbps. Mercury devices have dedicated differential buffers and circuitry to support LVDS, LVPECL, and 3.3-V PCML I/O standards. Two dedicated high-speed PLLs (separate from the general purpose PLLs) multiply reference clocks and drive high-speed differential serializer/deserializer channels. In addition, clock recovery units (CRUs) at each receiver channel enable CDR. EP1M120 devices support eight input channels, eight output channels, and two dedicated clock inputs for feeding the receiver and/or transmitter PLLs. EP1M350 devices support 18 input channels, 18 output channels, and two dedicated clock inputs.

Mercury devices have optional built-in 100- $\Omega$  termination resistors on HSDI differential receiver data pins and the HSDI\_CLK1 and HSDI\_CLK2 pins.

Designers can use the HSDI circuitry for the following applications:

- Gigabit Ethernet backplanes
- ATM, SONET
- RapidIO
- POS-PHY Level 4
- Fibre Channel
- SDTV

The HSDI band supports one of two possible modes:

- Source-synchronous mode
- Clock data recovery (CDR) mode

In source-synchronous mode, source synchronous interfacing is supported at up to 840 Mbps. Serial channels are transmitted and received along with a low speed clock. The receiving device then multiplies the clock by a factor of 1 to 12, 14, 16, 18, or 20. The serialization/deserialization rate can be any number from 4, 7, 8, 9 to 12, 14, 16, 18, or 20 and does not have to equal the clock multiplication value. For example, an 840-Mbps LVDS channel can be received along with a 84-MHz clock. The 84-MHz clock is multiplied by 10 to drive the serial shift register, but the register can be clocked out in parallel at 7-, 8-, 9- to 12-, 14-, 16-, 18-, or 20-bits wide at 42 to 120 MHz. See Figures 2 and 3.

Figure 2. Receiver Diagram for Source Synchronous Mode Notes (1), (2)

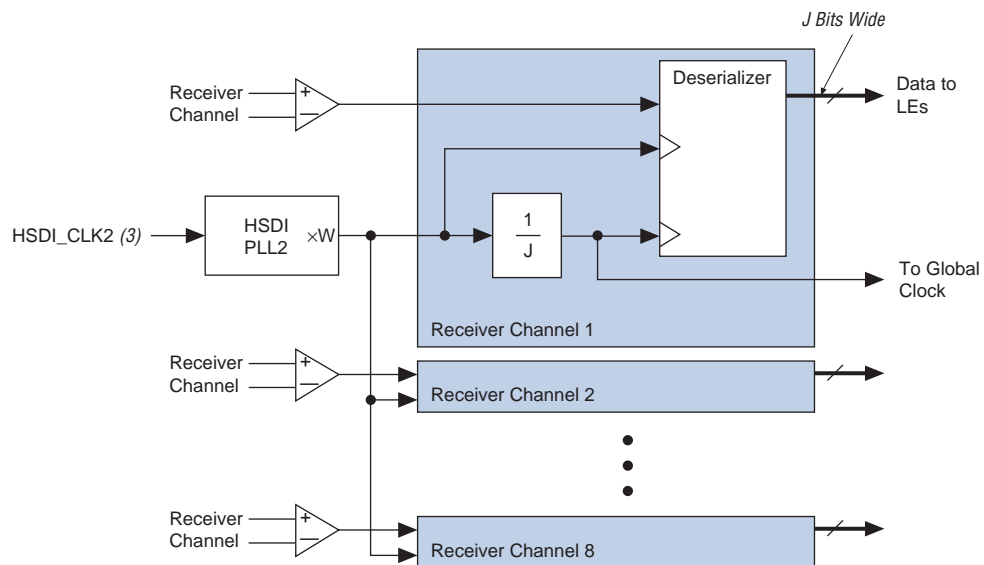

**Notes to Figure 2:**

- (1) EP1M350 devices have 18 individual receiver channels. EP1M120 devices have 8 individual receiver channels.
- (2)  $W = 1$  to 12, 14, 16, 18, or 20  
 $J = 4, 7, 8, 9$  to 12, 14, 16, 18, or 20  
 $W$  does not have to equal  $J$ .
- (3) This clock pin drives an HSDI PLL only. It does not drive to the core.

Figure 3. Transmitter Diagram for Source Synchronous Mode Notes (1), (2)

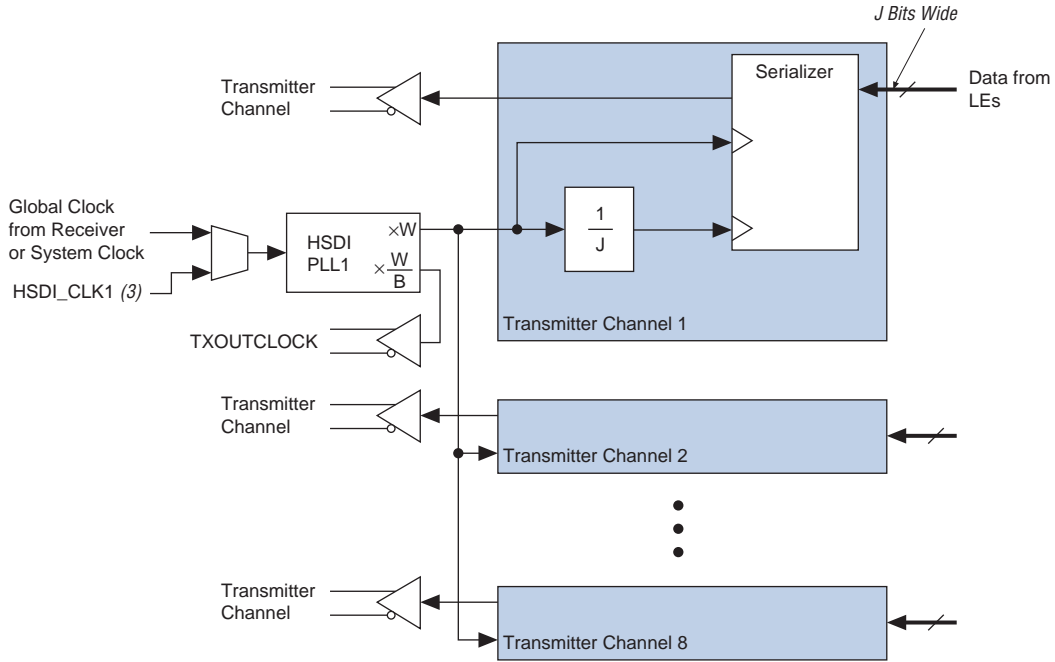

**Notes to Figure 3:**

- (1) EP1M350 devices have 18 individual transmitter channels. EP1M120 devices have 8 individual transmitter channels.
- (2)  $W = 1$  to 12, 14, 16, 18, or 20  
 $B = 1$  to 12, 14, 16, 18, or 20  
 $J = 4, 7, 8, 9$  to 12, 14, 16, 18, or 20  
 $W, B,$  and  $J$  do not have to be equal.
- (3) This clock pin drives an HSDI PLL only. It does not drive to the logic array.

The Mercury device's source-synchronous mode also supports the RapidIO interface protocol at up to 500 Mbps using the LVDS I/O standard.



For more information on source synchronous interfacing see [AN 159: Using HSDI in Source-Synchronous Mode in Mercury Devices.](#)

Table 6 defines the support for source-synchronous mode applications.

<i>Table 6. Source-Synchronous Mode</i>			
Data Rate	I/O Standard		
	LVDS	LVPECL	3.3-V PCML
≤ 840 Mbps	(1)	✓	✓

**Note to Table 6:**

- (1) You can use the CDR circuit to achieve data rates for DC coupled LVDS applications. You must AC-couple the clock to a 2.2-V common mode voltage ( $V_{CM}$ ) using the AC-coupling schemes in *AN 134: Using Programmable I/O Standards in Mercury Devices*. The data channels should be DC-coupled. The byte alignment relative to the clock is lost when using the CDR circuit. Therefore, a byte-alignment circuit is required. Most Mercury source-synchronous designs already include byte-alignment logic since they usually use DDR or SDR clocks. The CDR run length requirement is waived if the reference clock and the receiver data come from the same source and have the same frequency.

In CDR mode, serial data is supported up to 1.25 Gbps per channel. The system provides a reference clock which is multiplied by the receiver or transmitter PLL to the same rate as the data is provided. For the receiver, this multiplied reference clock is used by a CRU on each receiver channel to generate a recovered clock in-phase with the received data. That recovered clock drives the programmable deserializer and synchronizer. The synchronizer is a FIFO for data transfer between the recovered clock domain and the global clock domain. The dedicated synchronizers can be bypassed if necessary. For every receiver channel in the EP1M350 and EP1M120 devices, the  $\div J$  recovered clock can drive a priority column line for use as a clock. See [Figure 4](#).

Figure 4. Receiver & Transmitter Diagrams for CDR Mode Notes (1), (2)

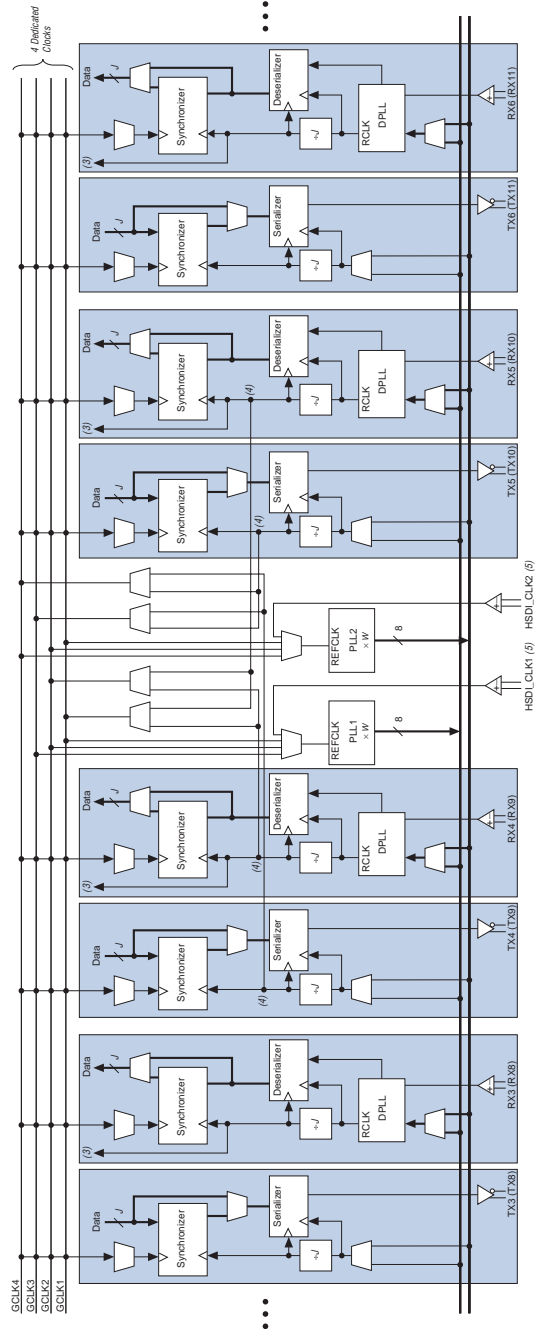

**Notes to Figure 4:**

- (1) EP1M350 devices have 18 individual receiver and transmitter channels. EP1M120 devices have 8 individual receiver and transmitter channels. Receiver and transmitter channel numbers in parenthesis are for EP1M350 devices.
- (2)  $W = 1$  to 12, 14, 16, 18, or 20  
 $J = 3$  to 12, 14, 16, 18, or 20  
 $W$  does not have to equal  $J$ .
- (3) For every receiver channel in EP1M350 and EP1M120 devices, the  $\pm J$  recovered clock can drive the priority column interconnect for use as a clock.
- (4) The two center channels adjacent to the HSDI PLLs (channels 4 and 5 for EP1M120 devices, channels 9 and 10 for EP1M350 devices) can drive the Mercury device's global clocks.
- (5) HSDI\_CLK1 and HSDI\_CLK2 pins must be differential. These clock pins drive HSDI PLLs only. They do not drive to the logic array.

The multiplied reference clock is also used to synchronize and serialize at the transmitter side.

Up to two different serial data rates are supported for input channels or output channels. Received data must be non-return-to-zero (NRZ).

Table 7 defines the support for CDR-mode applications. Table 8 shows the supported data rates for each speed grade.

Data Rate	CDR Mode					
	DC-Coupled LVDS	DC-Coupled LVPECL	DC-Coupled 3.3-V PCML	AC-Coupled LVDS (1)	AC-Coupled LVPECL (1)	AC-Coupled 3.3-V PCML (1)
1.0 to 1.25 Gbps	(2)	✓	✓	✓	✓	✓
≤ 1.0 Gbps	✓	✓	✓	✓	✓	✓

**Notes to Table 7:**

- (1) The  $V_{CM}$  operating range for AC-coupled applications is from 0 to 0.7 V and from 1.8 to 2.4 V.
- (2) Use AC-coupled LVDS or another I/O standard. The DC-coupled LVDS I/O standard provides performance up to 1.0 Gbps.



For more information on CDR, see [AN 130: CDR in Mercury Devices](#).



Mercury device HSDI performance is finalized for certain speed grades. Also, the industrial-grade CDR specification is the same as the -6 speed grade for commercial-grade CDR specification. See [Table 8](#).

Device	Speed Grade	Number of Channels	Maximum CDR Data Rate (Gbps)	Maximum Source-Synchronous Data Rate (Mbps)
EP1M120	-5	8	1.25	840
	-6 (1)	8	1.25	840
	-7	8	1.0	840
EP1M350	-5	18	1.25	840
	-6 (1)	8 (2)	1.25	840
		10 (2)	1.0	840
	-7	18	1.0	840

**Notes to Table 8:**

- (1) The -6 speed grade specifications apply for both commercial and industrial devices.
- (2) EP1M350 devices can support any 8 channels at 1.25 Gbps. The other 10 channels must run at 1.0 Gbps or less.

## Logic & Interconnect

Mercury device logic is implemented in LEs. LE resources are used differently according to specific operating modes and the type of logic function being implemented. LEs are grouped into LABs in a row-based architecture. The multi-level FastTrack Interconnect structure provides the routing connection between LEs, ESBs, and IOEs.

### Logic Array Block

Each LAB consists of 10 LEs, LE carry chains, multiplier circuitry, LAB control signals, local interconnect, and FastLUT connection lines. The local interconnect transfers signals between LEs within the same or adjacent LABs. FastLUT connections transfer the output of one LE to the adjacent LE for ultra-fast sequential LE connections within the same LAB. The Quartus II Compiler places associated logic within a LAB or adjacent LABs, allowing the use of fast local and FastLUT connections for high performance. [Figure 5](#) shows the Mercury LAB structure.

Figure 5. Mercury LAB Structure

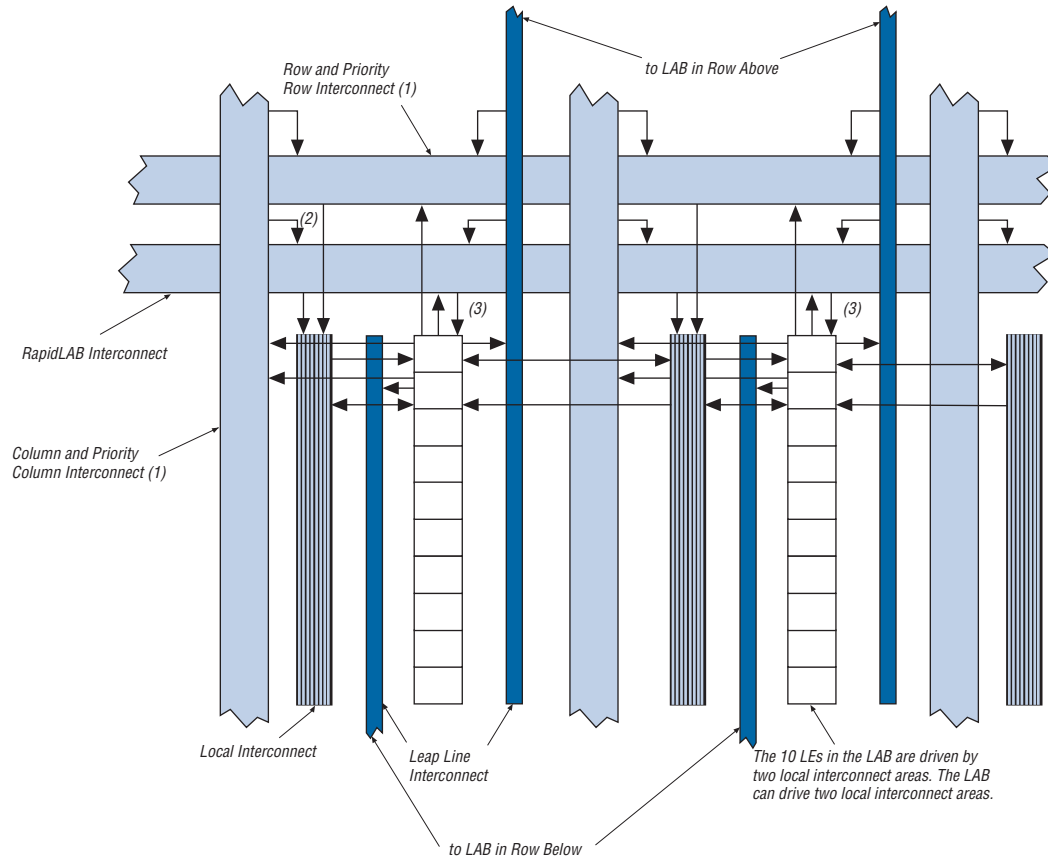
**Notes to Figure 5:**

- (1) Priority column lines drive priority row lines, but not other row lines.
- (2) The RapidLAB interconnect can be driven by priority column lines, but not other column lines.
- (3) In multiplier mode, the RapidLAB interconnect drives LEs directly.

Mercury devices use an interleaved LAB structure, which allows each LAB to drive two local interconnect areas. Every other LE drives to either the left or right local interconnect area, alternating by LE. The local interconnect can drive LEs within the same LAB or adjacent LABs. This feature minimizes use of the row and column interconnects, providing higher performance and flexibility. Each LAB structure can drive 30 LEs through fast local interconnects.

Each LAB contains dedicated logic for driving control signals to its LEs. The control signals include clock, clock enable, asynchronous clear, asynchronous preset, asynchronous load, synchronous clear, and synchronous load signals. A maximum of six control signals can be used at a time. Although synchronous load and clear signals are generally used when implementing counters, they can also be used with other functions.

Each LAB can use two clocks and two clock enable signals. Each LAB's clock and clock enable signals are linked (e.g., any LE in a particular LAB using LABCLK1 will also use LABCLKENA1). In addition to LAB-wide control of clock enables, Mercury devices can also control clock enable signals on individual LEs, allowing more than two clock enables in a given LAB. The Quartus II software automatically chooses whether a clock enable is LAB-wide for individual LEs. If both the rising and falling edges of a clock are used in a LAB, both LAB-wide clock signals are used.

The LAB local interconnect, fast global signals, row-global signals, and dedicated clock pins can generate the LAB-wide control signals. The multi-level FastTrack Interconnect's inherent low skew allows it to be used for clock distribution. [Figure 6](#) shows the LAB control signal generation circuit.

Figure 6. LAB-Wide Control Signals

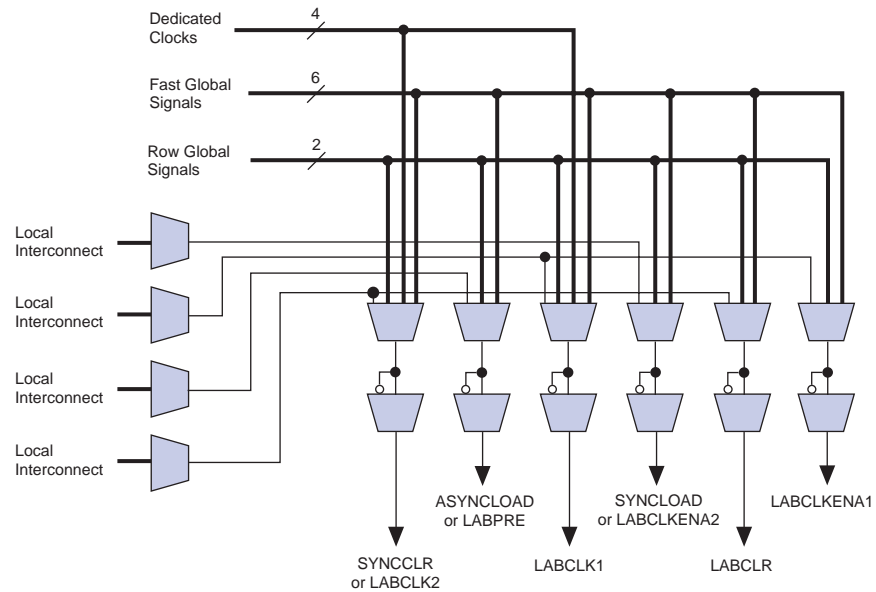

## Logic Element

The LE, the smallest unit of logic in the Mercury architecture, is compact and provides efficient logic usage. Each LE contains a four-input LUT, which is a function generator that can quickly implement any function of four variables. In addition, each LE contains a programmable register and carry chain with carry select look ahead capability. Each LE drives all interconnect types: local interconnect, row and priority row interconnect, column and priority column interconnect, leap lines, and RapidLAB interconnect. Each LE also has the ability to drive its combinatorial output directly to the next LE in the LAB using FastLUT connections. See [Figure 7](#).

Figure 7. Mercury LE

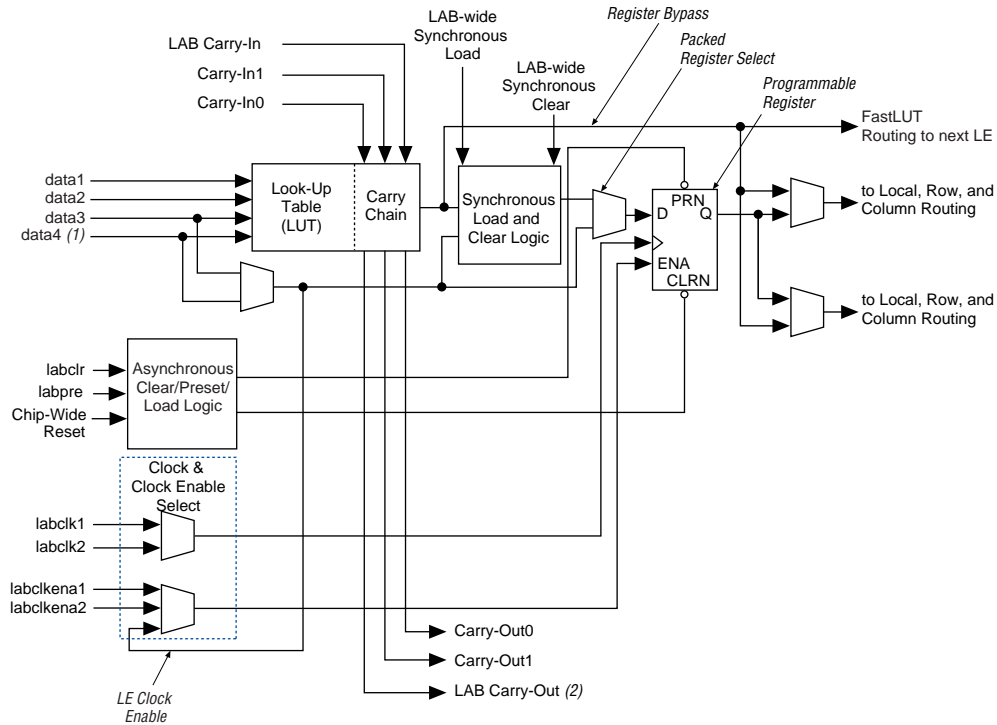

**Notes to Figure 7:**

- (1) FastLUT interconnect uses the data4 input.
- (2) LAB carry-out can only be generated by LE 4 and/or LE 10.

Each LE's programmable register can be configured for D, T, JK, or SR operation. The register's clock, clock enable, and clear control signals can be driven by global signals, general-purpose I/O pins, or any internal logic. For combinational functions, the register is bypassed and the output of the LUT drives directly to the outputs of the LE.

Each LE has four data inputs that can drive the internal LUT. One of these inputs has a shorter delay than the others, improving overall LE performance. This input is chosen automatically by the Quartus II software as appropriate.

Each LE has two outputs that drive the local, row, and column routing resources. Each output can be driven independently by the LUT's or register's output. For example, the LUT can drive one output, while the register drives the other output. This feature, called register packing, improves device utilization because the register and the LUT can be used for unrelated functions. The LE can also drive out registered and unregistered versions of the LUT output.

#### *LE Operating Modes*

The Mercury LE can operate in one of the following modes:

- Normal
- Arithmetic
- Multiplier

Each operating mode uses LE resources differently. In each operating mode, eight available inputs to the LE—the four data inputs from the LAB local interconnect; `carry-in0`, `carry-in1` from the previous LE; the LAB carry-in from the previous carry-chain generation; and the FastLUT Connection input from the previous LE—are directed to different destinations to implement the desired logic function. LAB-wide signals provide clock, asynchronous clear, asynchronous preset, asynchronous load, synchronous clear, synchronous load, and clock enable control for the register. These LAB-wide signals are available in all normal and arithmetic LE modes.

The Quartus II software, in conjunction with parameterized functions such as LPM and DesignWare functions, automatically chooses the appropriate mode for common functions, such as counters, adders, and multipliers. If required, the designer can also create special-purpose functions that specify which LE operating mode to use for optimal performance.

#### **Normal Mode**

The normal mode is suitable for general logic applications and combinatorial functions. In normal mode, four data inputs from the LAB local interconnect and a single carry-in are inputs to a four-input LUT. The Quartus II Compiler automatically selects the carry-in or the `data3` signal as one of the inputs to the LUT. The LUT (combinatorial) output can be driven to the FastLUT connection to the next LE in the LAB. LEs in normal mode support packed registers. [Figure 8](#) shows an LE in normal mode.

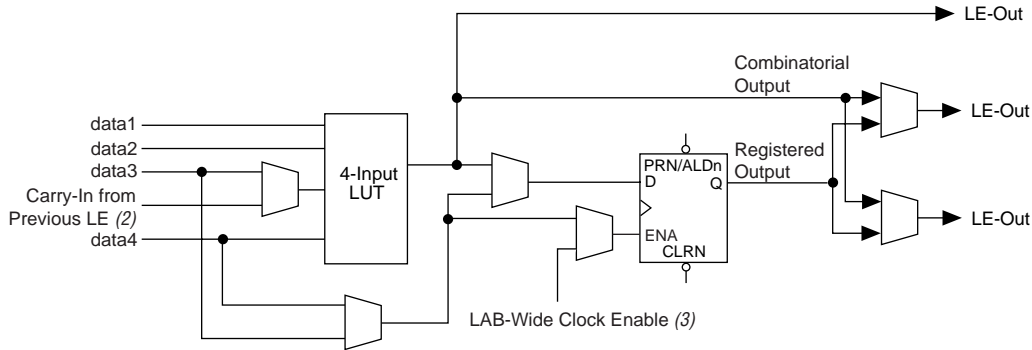
Figure 8. Normal-Mode LE *Note (1)***Notes to Figure 8:**

- (1) LEs in normal mode support register packing.
- (2) When using the carry-in in normal mode, the packed register feature is unavailable.
- (3) There are two LAB-wide clock enables per LAB in addition to LE-specific clock enables.

**Arithmetic Mode**

The arithmetic mode is ideal for implementing adders, accumulators, and comparators. A LE in arithmetic mode contains four 2-input LUTs. The first two 2-input LUTs compute two summations based on a possible carry of 1 or 0; the other two LUTs generate carry outputs for the two possible chains of the carry-select look-ahead (CSLA) circuitry. As shown in Figure 9, the LAB carry-in signal selects the appropriate carry-in chain (either carry-in0 or carry-in1). The logic level of the chain selected in turn selects which parallel sum is generated as a combinatorial or registered output. For example, when implementing an adder, this output is the signal comprised of the sum  $data1 + data2 + carry$ , where  $carry$  is 0 or 1. The other two LUTs use the  $data1$  and  $data2$  signals to generate two possible carry-out signals—one for a carry of 1 and the other for a carry of 0. The carry-in0 signal acts as the carry select for the carry-out0 output; carry-in1 acts as the carry select for the carry-out1 output. LEs in arithmetic mode can drive out registered and unregistered versions of the LUT output. Figure 9 shows a Mercury LE in arithmetic mode.



The CSLA chain's speed advantage results from the parallel pre-computation of carry chains. Instead of including every LUT in the critical path, only the propagation delays between LAB carry-in generation circuits (LE 4 and LE 10) make up the critical path. This feature allows the Mercury architecture to implement high-speed counters, adders, multipliers, parity functions, and comparators of arbitrary width.

Figure 10 shows the CSLA circuitry in a LAB for a 10-bit full adder. One portion of the LUT generates the sum of two bits using the input signals and the appropriate carry-in bit; the sum is routed to the output of the LE. The register can be bypassed for simple adders or used for accumulator functions. Another portion of the LUT generates carry-out bits. A lab-wide carry-in bit selects which chain is used for the addition of given inputs. The actual carry-in signal for that selected chain, `carry-in0` or `carry-in1`, selects the carry-out to carry forward, which is routed to the carry-in signal of the next-higher-order bit. The final carry-out signal is routed to an LE, where it is driven to local, row, or column interconnects.

Figure 10. CSLA Details

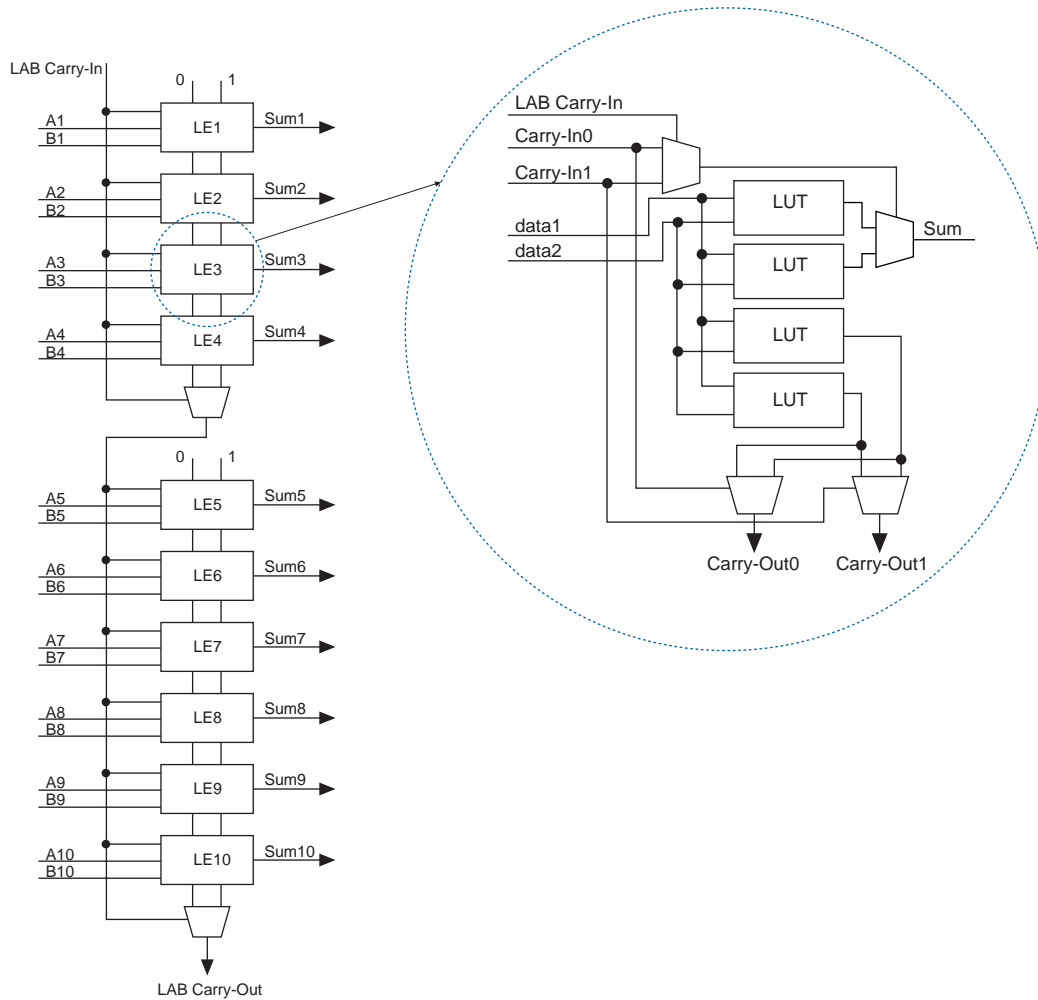

The Quartus II Compiler can create CSLA logic automatically during design processing. Alternatively, the designer can create CSLA logic manually during design entry. Parameterized functions such as library of parameterized modules (LPM) and DesignWare functions automatically take advantage of carry chains for the appropriate functions.

The Quartus II Compiler creates carry chains longer than ten LEs by linking LABs together automatically. For enhanced fitting, a long carry chain skips intermediate LABs in a row structure. A carry chain longer than one LAB skips either from an even-numbered LAB to the next even-numbered LAB, or from an odd-numbered LAB to the next odd-numbered LAB. For example, the last LE of the first LAB in a LAB row carries to the first LE of the third LAB in the same LAB row.

### Multiplier Mode

Multiplier mode is used for implementing high-speed multipliers up to  $16 \times 16$  in size. The LUT implements the partial product formation and summation in a single stage for a  $N \times M$ -bit multiply operation. A single LE can implement the summation of  $A_N B_{M+1} + A_{N+1} B_M$  for the multiplier and multiplicand inputs. To increase the speed of the multiplication, LAB wide signals are used to control the partial product sum generation. These multiplier LAB-wide signals use the LABCLKENA1 and PRESET/ASYNLOAD resources. The multiplier mode takes advantage of the CSLA circuitry for optimized sum and carry generation in the partial product sum. There is a special CSLA circuitry mode used for the multiplier where the carry chain runs vertically between LABs in the same column. The Quartus II Compiler automatically uses this special mode for dedicated multiplier implementation only. The summation of the multiplier and multiplicand bits is driven out along with the carry-out0 and carry-out1 bits. The combinatorial or registered versions of the sum can be driven out, allowing the multiplier to be pipelined.

The RapidLAB interconnect has dedicated fast connections to the LE inputs in multiplier mode, further increasing the speed of the multiplier. These dedicated connections allow RapidLAB lines to avoid delay incurred by driving onto local interconnects and then into the LE.

The Quartus II software implements parameterized functions that use the multiplier mode automatically when multiply operators are used.

Figure 11 shows a Mercury device LE in multiplier mode.

Figure 11. Multiplier Mode LE

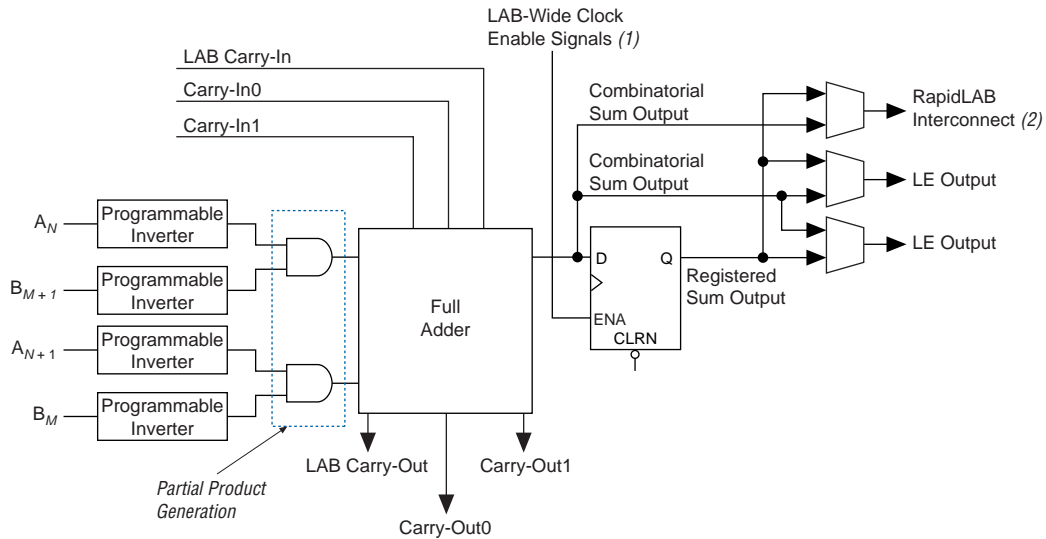
**Notes to Figure 11:**

- (1) LABCLKENA1 cannot be used in multiplier mode.
- (2) When the RapidLAB output is used, local interconnect outputs are unavailable.

The basis for the high-speed  $16 \times 16$ -bit multiplier in a Mercury device is the binary tree multiplier. In the first stage of the binary tree, the multiplicand bits,  $a[15:0]$ , and the multiplier bits,  $b[15:0]$ , are multiplied together. The results of the first stage are sixteen 16-bit partial products,  $a[15:0]b[15]$ ,  $a[15:0]b[14]$ ,  $\dots$ ,  $a[15:0]b[0]$ . The partial products are then grouped into pairs and added together in the second stage. In a similar fashion, the results of the previous stage are grouped in pairs and then added forming the binary tree structure seen in Figure 12.

Figure 12. Partial Product Formation

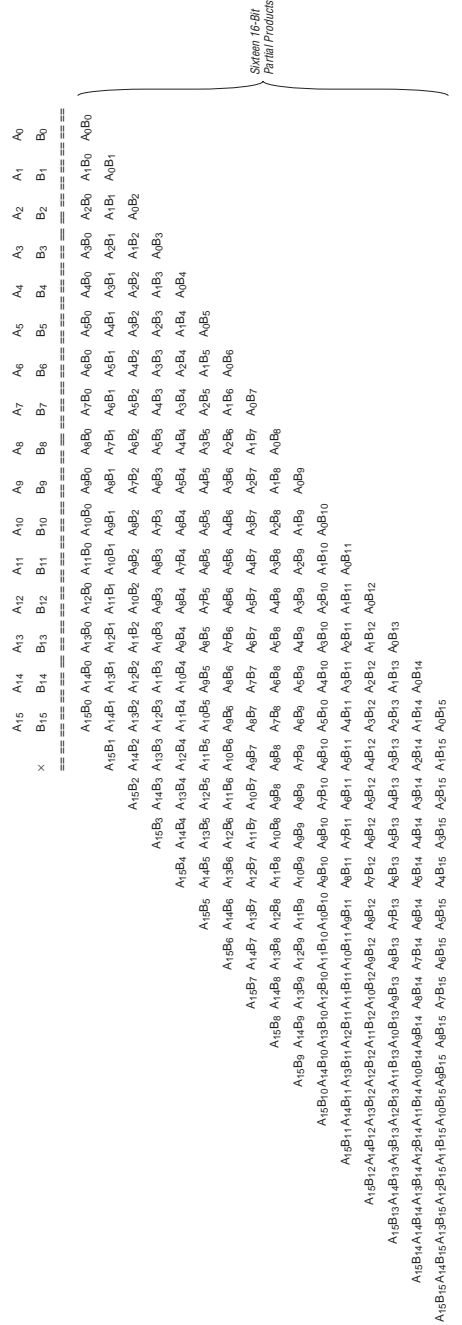

For a typical  $16 \times 16$ -bit binary tree multiplier, five stages are needed to determine the final product. The Mercury LE multiplier mode allows the partial product formation stage (Stage 1) and the first sum of stages (Stage 2) to be combined in a single stage, shown in [Figure 13](#). This feature, combined with the direct connection between RapidLAB lines and LEs in multiplier mode, allows the fast dedicated implementation of multipliers.

Figure 13. Mercury Binary Tree Implementation

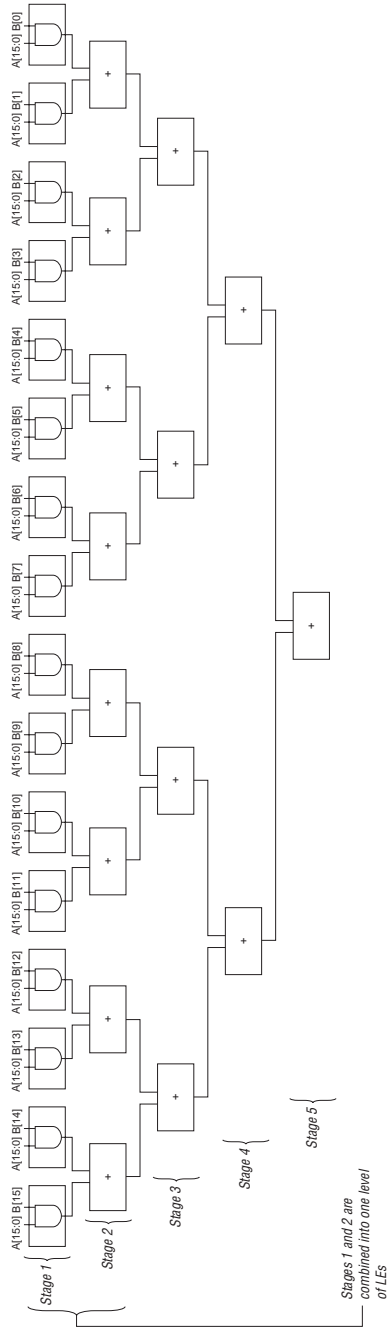

### *Clear & Preset Logic Control*

LAB-wide signals control logic for the register's clear and preset signals. The LE directly supports an asynchronous clear and preset function. The direct asynchronous preset does not require a NOT-gate push-back technique. Mercury devices support simultaneous preset, or asynchronous load, and clear. Asynchronous clear takes precedence if both signals are asserted simultaneously. Each LAB supports one clear and one preset signal. Two clears are possible in a single LAB by using a NOT-gate push-back technique on the preset port. The Quartus II Compiler automatically performs this second clear emulation.

In addition to the clear and preset ports, Mercury devices provide a chip-wide reset pin (`DEV_CLRn`) that resets all registers in the device. Use of this pin is controlled through an option in the Quartus II software that is set before compilation. The chip-wide reset overrides all other control signals.

### **Multi-Level FastTrack Interconnect**

The Mercury architecture provides connections between LEs, ESBs, and device I/O pins via an innovative Multi-Level FastTrack Interconnect structure. The Multi-Level FastTrack Interconnect structure is a series of routing channels that traverse the device, providing a hierarchy of interconnect lines. Regular resources provide efficient and capable connections while priority resources and specialized RapidLAB, leap line, and FastLUT resources enhance performance by accelerating timing on critical paths. The Quartus II Compiler automatically places critical design paths on those faster lines to improve design performance.

This network of routing structures provides predictable performance, even for complex designs. In contrast, the segmented routing in FPGAs requires switch matrices to connect a variable number of routing paths, increasing the delays between logic resources and reducing performance.

The Multi-Level FastTrack Interconnect consists of regular and priority lines that traverse column and row interconnect channels to span sections and the entire device length. Each row of LABs, ESBs, and I/O bands is served by a dedicated row interconnect, which routes signals to and from LABs, ESBs, and I/O row bands in the same row. These row resources include:

- Row interconnect traversing the entire device from left to right
- Priority row interconnect for high speed access across the length of the device
- RapidLAB interconnect for horizontal routing that traverses a 10-LAB-wide region from a central LAB

The RapidLAB interconnect provides a specialized high-speed structure to allow a central LAB to drive other LABs within a 10-LAB-wide region. The RapidLAB lines drive alternating local LAB interconnect regions, allowing communication to all LABs in the 10-LAB-wide region. Even numbered LEs in a LAB directly drive a RapidLAB line that drives one set of alternating local interconnect regions, while odd-numbered LEs drive a RapidLAB line that drives the opposite set of alternating local interconnect regions. [Figure 14](#) shows RapidLAB interconnect connections. This 10-LAB wide region of the RapidLAB interconnect is repeated for every LAB in the row. The region covered by the RapidLAB interconnect is smaller than 10 for source LABs that are four or five LABs in from either edge of the LAB row. The RapidLAB row interconnect is used for LAB-to-LAB routing; it is only used by I/O bands or ESBs indirectly through other interconnects. The RapidLAB interconnect drives an LE directly when that LE is in multiplier mode.

Figure 14. RapidLAB Interconnect Connections

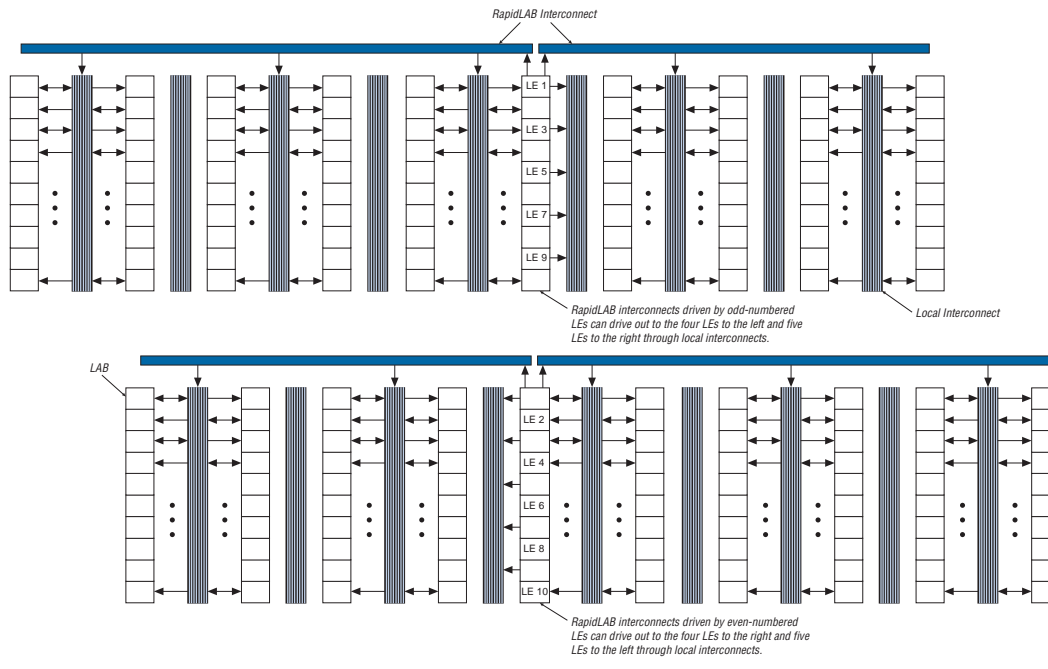

The column interconnect vertically routes signals to and from LABs, ESBs, and I/O bands. Each column of LABs is served by a dedicated column interconnect. These column resources include:

- Column interconnect traversing the entire device from top to bottom
- Priority column interconnect for high speed access across the device vertically
- Leap line interconnect for vertical routing between adjacent LAB rows and between adjacent ESP rows and LAB rows.

Leap lines are driven directly by LEs for fast access to adjacent row interconnects. LABs can drive a leap line to the row above and/or below (including ESB rows). The even-numbered LEs in a LAB drive leap lines down, while odd-numbered LEs drive leap lines up. This allows a single LAB to access row and RapidLAB interconnects within a three-row region. [Figure 15](#) shows the leap line interconnect.

Figure 15. Leap Line Interconnect

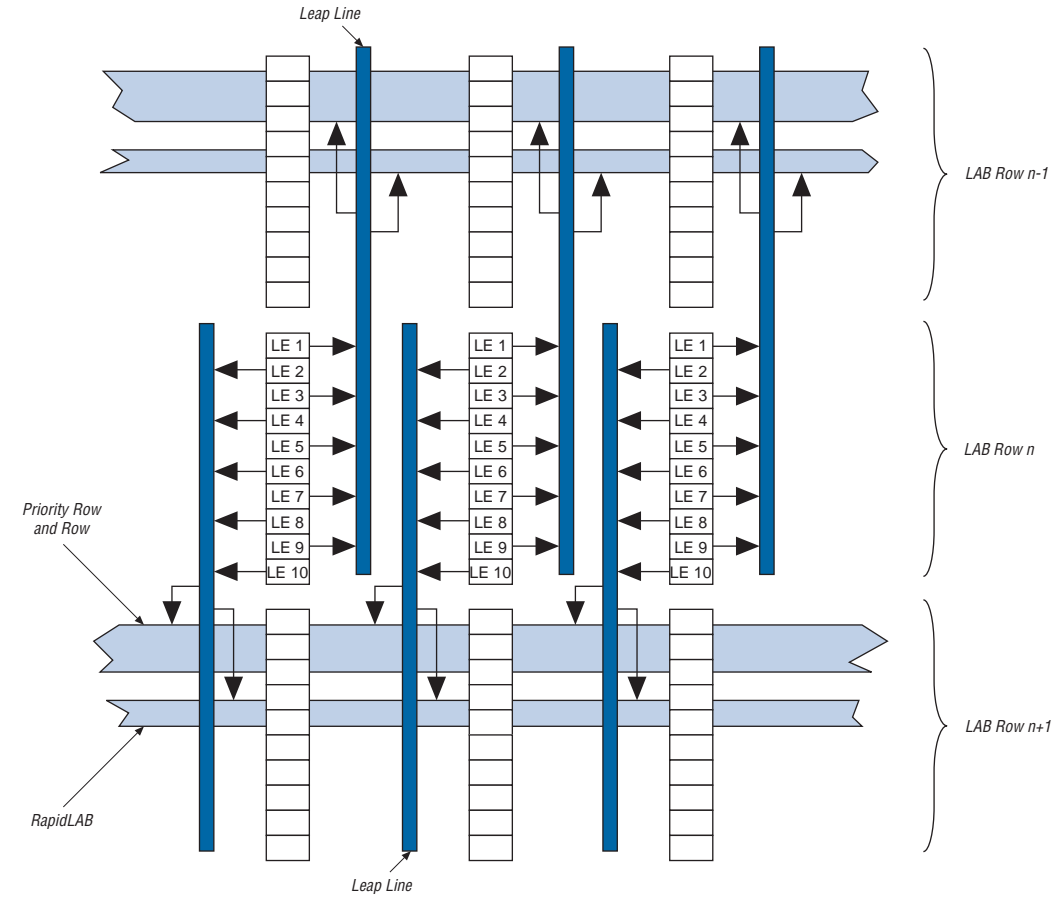

### FastLUT Interconnect

Mercury devices include an enhanced interconnect structure within LABs for faster routing of LE output to LE input connections. The FastLUT connection allows the combinatorial output of an LE to directly drive the fast input of the LE directly below it, bypassing the local interconnect. This resource can be used as a high speed connection for wide fan-in functions from LE 1 to LE 10 in the same LAB. Figure 16 shows a FastLUT interconnect.

Figure 16. FastLUT Interconnect

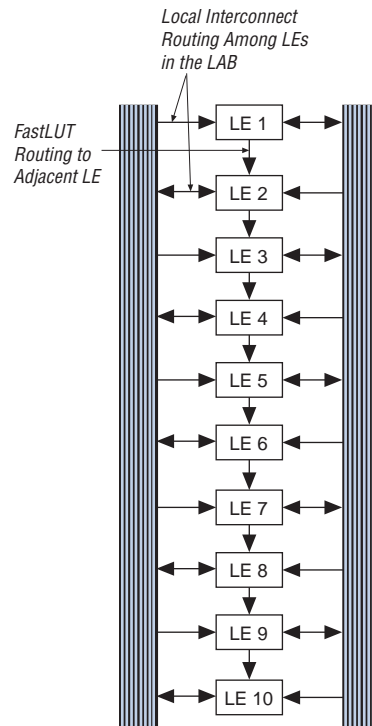

ESB rows also have their own interconnect resources to communicate horizontally and vertically with LAB rows. The ESB rows at the top and bottom of the device have their own set of row and priority row interconnect resources. For vertical communication, all LAB column interconnect lines traverse to the ESBs. This includes leap lines, which allow the adjacent LAB rows to communicate with the ESBs.

The row interconnect resources can be driven directly by LEs or ESBs in that row. Further, the column interconnect resources can drive a row line, allowing LEs, IOEs, and ESBs to drive elements in a different row via the column and row resources.

The column interconnect resources can be directly driven by LEs, IOEs, or ESBs within that column. The priority column and leap line resources can be driven directly by LEs. These lines enable high-speed vertical communication in the device for timing-critical paths. The column resources route signals between rows. A column resource can drive row resources directly, allowing fast connections between rows.

Table 9 summarizes how various elements of the Mercury architecture drive each other.

Source	Destination										
	LE	Local Interconnect	IOE	ESB Row Interconnect	ESB	Row	Priority Row	RapidLAB Interconnect	Column	Priority Column	Leap Lines
LE	✓ (1)	✓				✓	✓	✓	✓	✓	✓
Local Interconnect	✓		✓								
IOE		✓ (2)				✓ (3)	✓ (3)		✓	✓	
ESB Row Interconnect					✓						
ESB				✓					✓	✓	✓
Row		✓									
Priority Row		✓									
RapidLAB Interconnect	✓ (4)	✓									
Column				✓		✓	✓		✓		
Priority Column				✓			✓	✓	✓	✓	
Leap Lines				✓		✓	✓	✓	✓		

**Notes to Table 9:**

- (1) This direct connection is possible through the FastLUT connection.
- (2) IOEs can connect to the adjacent LAB's local interconnects in the associated LAB row.
- (3) IOEs can connect to row and priority row interconnects in the associated LAB row.
- (4) This connection is used for multiplier mode.

## Embedded System Block

The ESB can implement various types of memory blocks, including quad-port, true dual-port, dual- and single-port RAM, ROM, FIFO, and CAM blocks.

The ESB includes input and output registers; the input registers synchronize reads and/or writes, and the output registers can pipeline designs to further increase system performance. The ESB offers a quad port mode, which supports up to four port operations, two reads and two writes simultaneously, with the ability for a different clock on each of the four ports. Figure 17 shows the ESB quad-port block diagram.

Figure 17. ESB Quad-Port Block Diagram

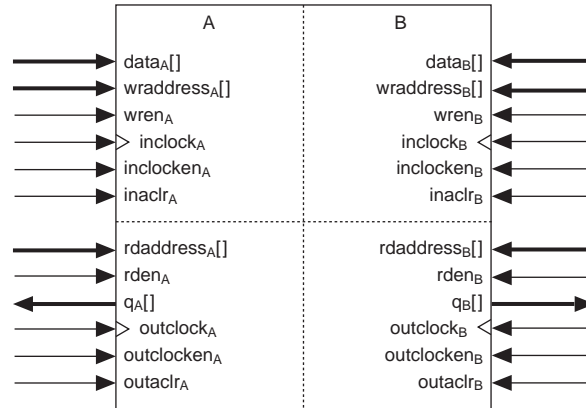

In addition to quad port memory, the ESB also supports true dual-port, dual-port, and single-port RAM. True dual-port RAM supports any combination of two port operations: two reads, two writes, or one read and one write. Dual-port memory supports a simultaneous read and write. For single-port memory, independent read and write is supported. [Figure 18](#) shows these different RAM memory port configurations for an ESB.

Figure 18. RAM Memory Port Configurations

True Dual-Port Memory

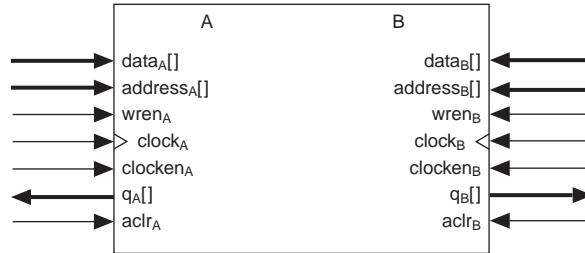

Dual-Port Memory (1)

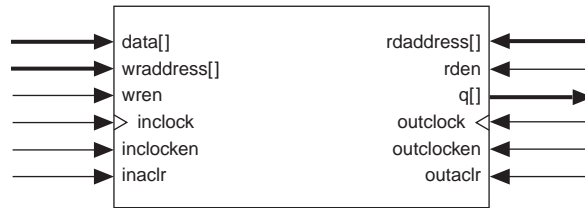

Single-Port Memory (1)

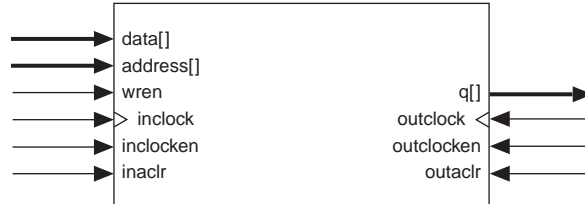

Note to Figure 18:

(1) Two dual- or single-port memory blocks can be implemented in a single ESB.

The ESB also allows variable width data ports for reading and writing to any of the RAM ports in any RAM configuration. For example, the ESB in quad port configuration can be written in  $\times 1$  mode at port A, read in  $\times 16$  from port A, written in  $\times 4$  mode at port B, and read in  $\times 2$  mode from port B.

ESBs can implement synchronous RAM, which is easier to use than asynchronous RAM. A circuit using asynchronous RAM must generate the RAM write enable ( $\overline{WE}$ ) signal while ensuring that its data and address signals meet setup and hold time specifications relative to the  $\overline{WE}$  signal. In contrast, the ESB's synchronous RAM generates its own  $\overline{WE}$  signal and is self-timed with respect to the global clock. Circuits using the ESB's self-timed RAM must only meet the setup and hold time specifications relative to the global clock.

ESBs are grouped together in rows at the top and bottom of the device for fast horizontal communication. The ESB row interconnect can be driven by any ESB in the row. The row interconnect drives the ESB local interconnect, which in turn drives the ESB ports. ESB outputs drive the ESB local interconnect, which can drive row interconnect as well as all types of column interconnect, including leap lines. The leap lines allow fast access between ESBs and the adjacent LAB row.

When implementing memory, each ESB can be configured in any of the following sizes for quad port and true dual-port memory modes:  $256 \times 16$ ;  $512 \times 8$ ;  $1,024 \times 4$ ;  $2,048 \times 2$ ; or  $4,096 \times 1$ . For dual-port and single-port modes, the ESB can be configured for  $128 \times 32$  in addition to the list above. For variable port width RAMs, any port width ratio combination must be 1, 2, 4, 8, or 16. For example, a RAM with data ports of width 1 and 16 or 2 and 32 will work, but not 1 and 32.

The ESB can also be split in half and used for two independent 2,048-bit single-port or dual-port RAM blocks. For example, one half of the ESB can be used as a  $128 \times 16$  memory single-port memory while the other half can be used for a  $1,024 \times 2$  dual-port memory. This effectively doubles the number of RAMs a Mercury device can implement for its given number of ESBs. The Quartus II software automatically merges two logical memory functions in a design into an ESB; the designer does not need to merge the functions manually.

By combining multiple ESBs, the Quartus II software implements larger memory blocks automatically. For example, two  $256 \times 16$  RAM blocks can be combined to form a  $256 \times 32$  RAM block, and two  $512 \times 8$  RAM blocks can be combined to form a  $512 \times 16$  RAM block. Memory performance does not degrade for memory blocks up to 4,096 words deep. Each ESB can implement a 4,096-word-deep memory; the ESBs are used in parallel, eliminating the need for any external control logic and its associated delays. To create a high-speed memory block more than 4,096 words deep, the Quartus II software will automatically combine ESBs with LE control logic.

The ESB implements two forms of clocking modes for quad-port and dual-port memory—read/write clock mode and input/output clock mode.

### Read/Write Clock Mode

An ESB implementing quad-port memory in read/write clock mode can use up to four clocks. For port A, one clock controls all registers associated with writing: data input,  $WE$ , and write address. The other clock controls all registers associated with reading: read enable ( $RE$ ), read address, and data output. Another set of clocks can be used for port B of the RAM, or the same clocks can be used. Each ESB port, A or B, also supports independent read clock enable, write clock enable, and asynchronous clear signals. Read/write clock mode is commonly used for applications where reads and writes occur at different system frequencies. [Figure 19](#) shows the ESB in read/write clock mode.

Figure 19. ESB in Read/Write Clock Mode Notes (1), (2)

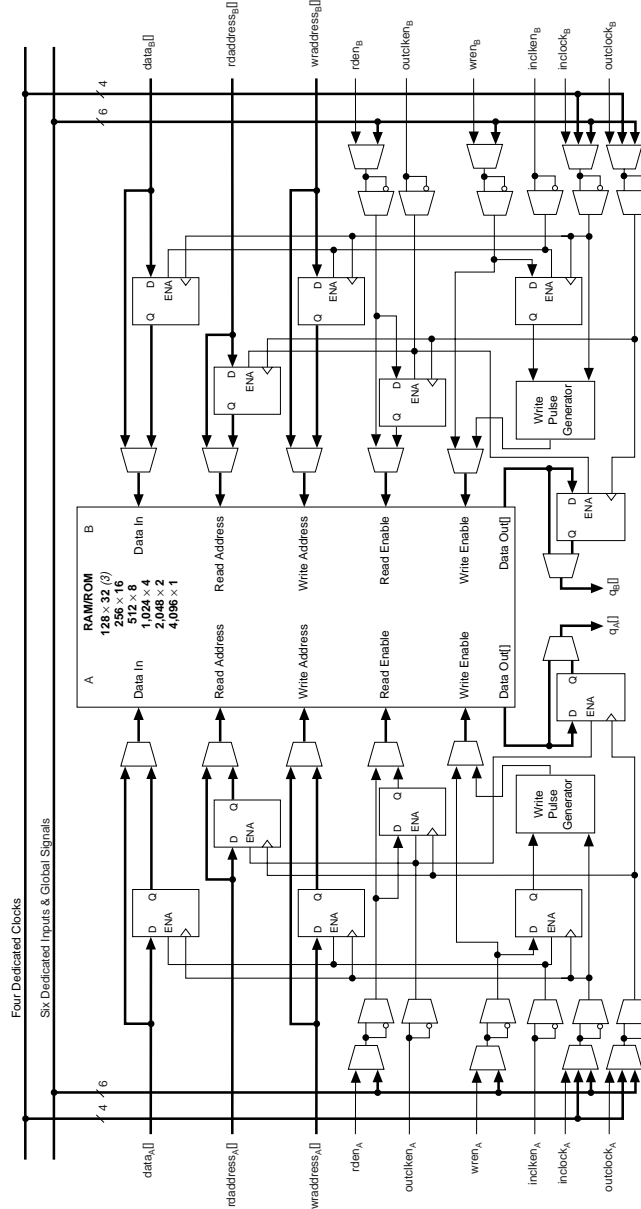

Notes to Figure 19:

- (1) Only half of the ESB, either A or B, is used for dual-port configuration.
- (2) All registers can be asynchronously cleared by ESB local interconnect signals, global signals, or the chip-wide reset.
- (3) This configuration is supported for dual-port configuration.

### Input/Output Clock Mode

An ESB using input/output clock mode can also use up to four clocks. On each of the two ports, A or B, one clock controls all registers for inputs into the ESB: data input, WE, RE, read address, and write address. The other clock controls the ESB data output registers. Each ESB port, A or B, also supports independent read clock enable, write clock enable, and asynchronous clear signals. Input/output clock mode is commonly used for applications where the reads and writes occur at the same system frequency, but require different clock enable signals for the input and output registers. [Figure 20](#) shows the ESB in input/output clock mode.

Figure 20. ESB in Input/Output Clock Mode Notes (1), (2)

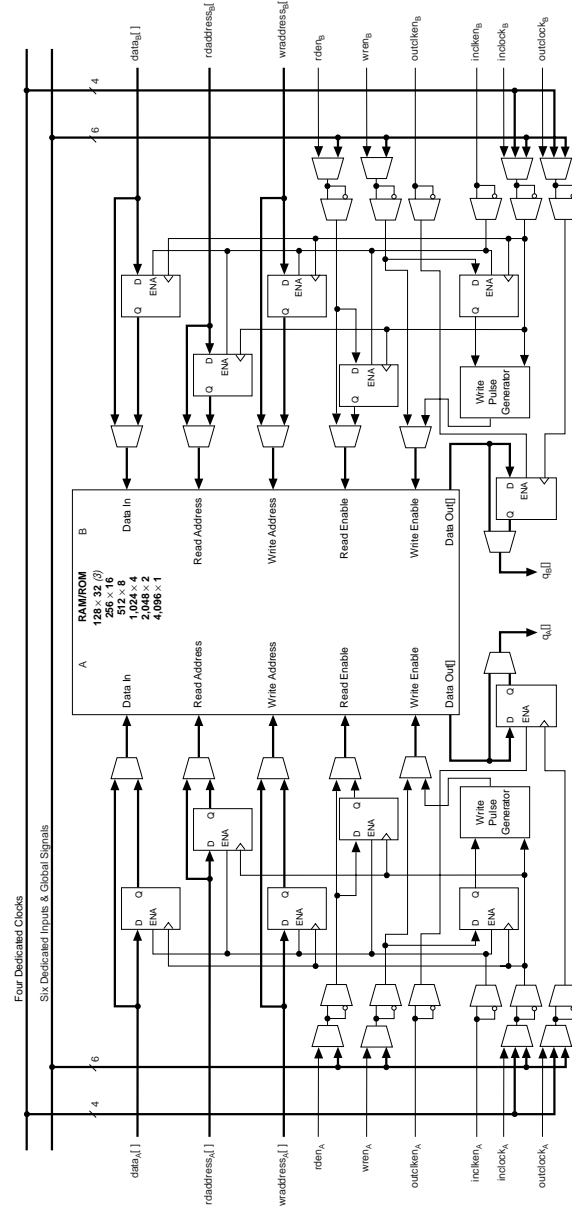

Notes to Figure 20:

- (1) Only half of the ESB, either A or B, is used for dual-port configuration.
- (2) All registers can be asynchronously cleared by ESB local interconnect signals, global signals, or the chip-wide reset.
- (3) This configuration is supported for dual-port configuration.

## Single-Port Mode

The Mercury device's ESB also supports a single-port mode, which is used when simultaneous reads and writes are not required. See [Figure 21](#). A single ESB can support up to two single-port mode RAMs.

**Figure 21. ESB in Single-Port Mode** *Note (1)*

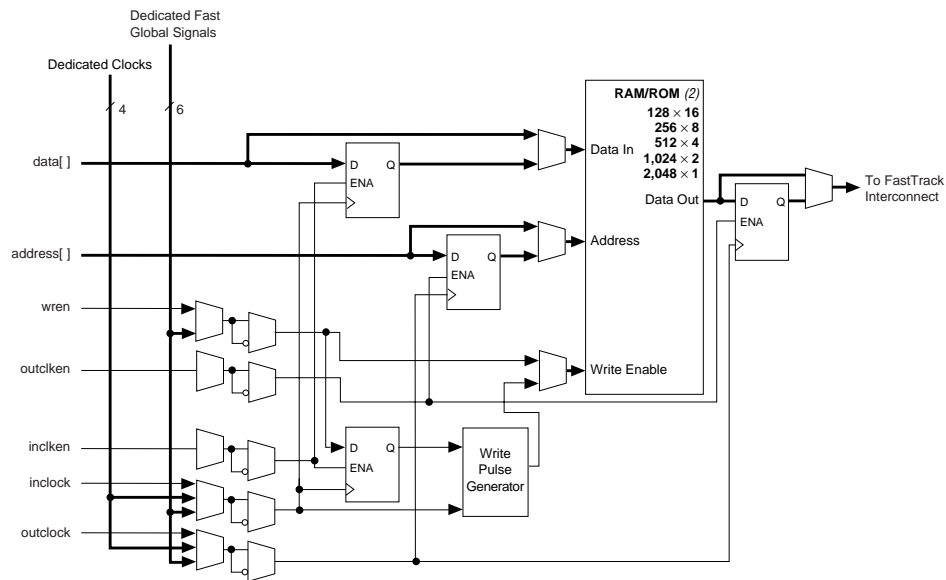

**Notes to Figure 21:**

- (1) All registers can be asynchronously cleared by ESB local interconnect signals, global signals, or chip-wide reset.
- (2) If there is only one single-port RAM block in an ESB, it can support the following configurations: 4,096 × 1; 2,048 × 2; 1,028 × 4; 512 × 8; 256 × 16; or 128 × 32.

## Content-Addressable Memory

Mercury devices can implement CAM in ESBs. CAM can be thought of as the inverse of RAM. RAM stores data in a specific location; when the system submits an address, the RAM block provides the data. Conversely, when the system submits data to CAM, the CAM block provides the address where the data is found. For example, if the data FA12 is stored in address 14, the CAM outputs 14 when FA12 is driven into it.

CAM is used for high-speed search operations. When searching for data within a RAM block, the search is performed serially. Thus, finding a particular data word can take many cycles. CAM searches all addresses in parallel and outputs the address storing a particular word. When a match is found, a match flag is set high. CAM is ideally suited for applications such as Ethernet address lookup, data compression, pattern recognition, cache tags, fast routing table lookup, and high-bandwidth address filtering. Figure 22 shows the CAM block diagram.

Figure 22. CAM Block Diagram

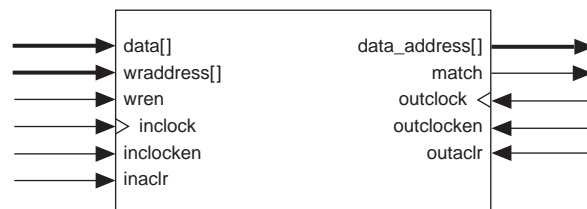

The Mercury on-chip CAM provides faster system performance than traditional discrete CAM. Integrating CAM and logic into the Mercury device eliminates off-chip and on-chip delays, improving system performance.

When in CAM mode, the ESB implements a 32-word, 32-bit CAM. Wider or deeper CAM, such as a 32-word, 64-bit or 128-word, 32-bit block, can be implemented by combining multiple CAM blocks with some ancillary logic implemented in LEs. The Quartus II software automatically combines ESBs and LEs to create larger CAM blocks.

CAM supports writing “don’t care” bits into words of the memory. The don’t-care bit can be used as a mask for CAM comparisons; any bit set to don’t-care has no effect on matches.

CAM can generate outputs in three different modes: single-match mode, multiple-match mode, and fast multiple-match mode. In each mode, the ESB outputs the matched data’s location as an encoded or unencoded address. When encoded, the ESB outputs an encoded address of the data’s location. For instance, if the data is located in address 12, the ESB output is 12. When unencoded, each ESB port uses its 16 outputs to show the location of the data over two clock cycles. In this case, if the data is located in address 12, the 12th output line goes high. Figures 22 and 23 show the encoded CAM outputs and unencoded CAM outputs, respectively.

Figure 23. Encoded CAM Address Outputs

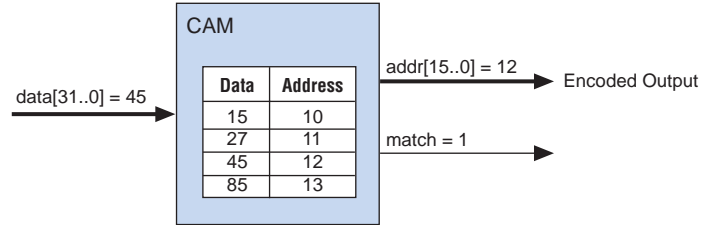
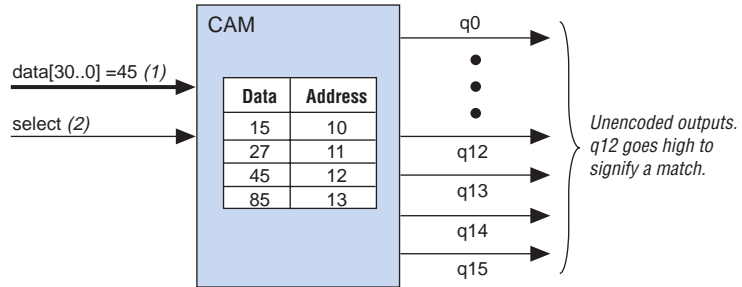

Figure 24. Unencoded CAM Address Outputs



**Notes to Figure 24:**

- (1) For an unencoded output, the ESB only supports 31 input data bits. One input bit is used by the `select` line to choose one of the two banks of 16 outputs.
- (2) If the `select` input is a 1, then CAM outputs odd words between 1 through 15. If the `select` input is a 0, CAM outputs words even words between 0 through 14.

In single-match mode, it takes two clock cycles to write into CAM, but only one clock cycle to read from CAM. In this mode, both encoded and unencoded outputs are available without external logic. Single-match mode is better suited for designs without duplicate data in the memory.

If the same data is written into multiple locations in the memory, a CAM block can be used in multiple-match or fast multiple-match modes. The ESB outputs the matched data's locations as an encoded or unencoded address. In multiple-match mode, it takes two clock cycles to write into a CAM block. For reading, there are 16 outputs from each ESB at each clock cycle. Therefore, it takes two clock cycles to represent the 32 words from a single ESB port. In this mode, encoded and unencoded outputs are available. To implement the encoded version, the Quartus II software adds a priority encoder with LEs. Fast multiple-match is identical to the multiple-match mode, however, it only takes one clock cycle to read from a CAM block and generate valid outputs. To do this, the entire ESB is used to represent 16 outputs. In fast multiple-match mode, the ESB can implement a maximum CAM block size of 16 words.

A CAM block can be pre-loaded with data during configuration, or it can be written during system operation. In most cases, two clock cycles are required to write each word into CAM. When don't-care bits are used, a third clock cycle is required.



For more information on CAM, see [Application Note 119 \(Implementing High-Speed Search Applications with APEX CAM\)](#).

## Driving into ESBs

ESBs provide flexible options for driving control signals. Different clocks can be used for the ESB inputs and outputs. Registers can be inserted independently on the data input, data output, read address, write address, `WREN`, and `RDEN` signals on each port of the ESB. The fast global signals and ESB local interconnect can drive the `WREN` and `RDEN` signals. The fast global signals, dedicated clock pins, and ESB local interconnect can drive the ESB clock signals. The ESB local interconnect is driven by the ESB row interconnects which, in turn, are driven by all types of column interconnects, including high-speed leap lines. Because the LEs drive the column interconnect to the ESB local interconnect, the LEs can control the `WREN` and `RDEN` signals and the ESB clock, clock enable, and asynchronous clear signals. [Figure 25](#) shows the ESB control signal generation logic.

Figure 25. ESB Control Signal Generation

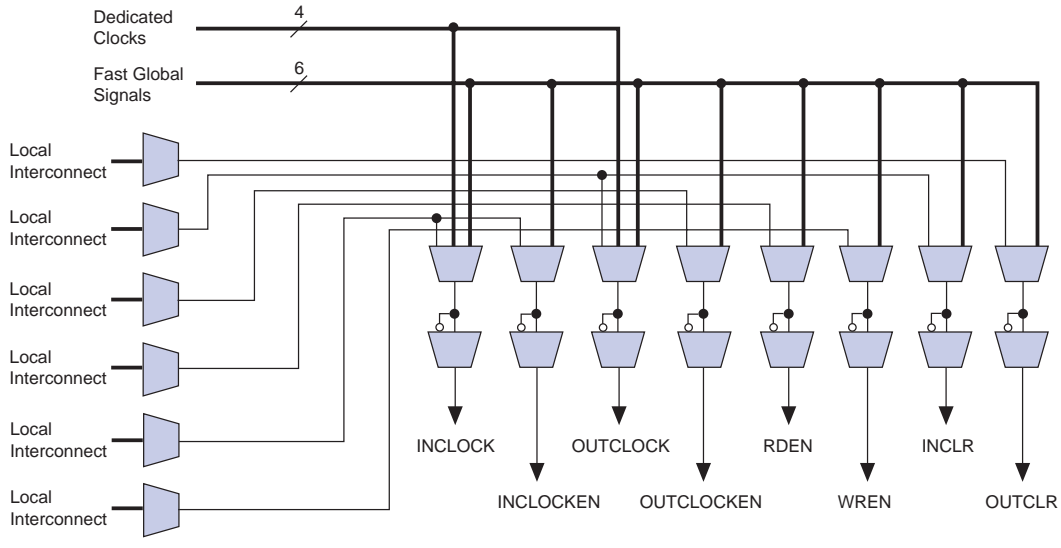

The ESB can drive row interconnects within its own ESB row and can directly drive all the column interconnects: column, priority column, and leap lines.

### Implementing Logic in ROM

In addition to implementing RAM functions, the ESB can implement logic functions when it is programmed with a read-only pattern during configuration, creating a large LUT. With LUTs, combinatorial functions are implemented by looking up the results, rather than by computing them. This implementation of combinatorial functions can be faster than using algorithms implemented in general logic, a performance advantage further enhanced by the fast access times of ESBs. The large capacity of ESBs enables designers to implement complex functions in one logic level without the routing delays associated with linked LEs or distributed RAM blocks. Parameterized functions such as LPM functions can take advantage of the ESB automatically. Further, the Quartus II software can implement portions of a design with ESBs where appropriate.

## Programmable Speed/Power Control

Mercury device ESBs offer the Turbo Bit™ option, a high-speed mode that supports fast operation on an ESB-by-ESB basis. When high speed is not required, the Turbo Bit option can be turned off to reduce power dissipation by up to 50%. ESBs that run at low power incur a nominal timing delay adder. An ESB that is not used will be powered down so it does not consume DC current.

Designers can program each ESB in the Mercury device for either high-speed or low-power operation. As a result, speed-critical paths in the design can run at high speed, while the remaining paths operate at reduced power.

## I/O Structure

The IOE in Mercury devices contains a bidirectional I/O buffer and three registers for a complete embedded bidirectional IOE. The IOE contains individual input, output, and output enable registers. The input register can be used for external data requiring fast setup times. The output register can be used for data requiring fast clock-to-output performance. The output enable (OE) register can be used for fast clock-to-output enable timing. The Quartus II software automatically duplicates a single OE register that controls multiple output or bidirectional pins.

For normal bidirectional operation, the input register can have its own clock input separate from the OE and output registers. The OE and output register share the same clock source. Each register can have its own clock enable signal from local interconnect in the associated LAB, fast global signals, or row global signals.

The Mercury IOE includes programmable delays that can be activated to ensure zero hold times, minimum clock-to-output times, input IOE register-to-core register transfers, or core-to-output IOE register transfers. A path in which a pin directly drives a register may require the delay to ensure zero hold time, whereas a path in which a pin drives a register through combinatorial logic may not require the delay. Programmable delays exist for decreasing input pin to core and IOE input register delays. The Quartus II Compiler can program these delays automatically to minimize setup time while providing a zero hold time. Delays are also programmable for increasing the register to pin delays for output and/or output enable registers. A programmable delay exists for increasing the  $t_{ZX}$  delay to the output pin, which is required for ZBT interfaces. [Table 10](#) shows the programmable delays for Mercury devices.

<i>Table 10. Mercury Programmable Delay Chain</i>	
Programmable Delays	Quartus II Logic Option
Input pin to core delay (1)	Decrease input delay to internal cells
Input pin to input register delay	Decrease input delay to input register
Output propagation delay	Increase delay to output pin
Output enable register $t_{CO}$ delay	Increase delay to OE pin
Output $t_{ZX}$ delay	Increase $t_{ZX}$ delay to output pin

**Note to Table 10:**

(1) This delay has four settings: off and three levels of delay.

The IOE registers in Mercury devices share the same source for clear or preset. Use of the preset/clear is programmable for each individual IOE. The register(s) can be programmed to power up high or low after configuration is complete. If programmed to power up low, an asynchronous clear can control the register(s). If programmed to power up high, an asynchronous preset can control the register(s). This feature prevents the inadvertent activation of another device's active-low input upon power-up. [Figure 26](#) shows the IOE for Mercury devices.

Figure 26. Mercury IOE

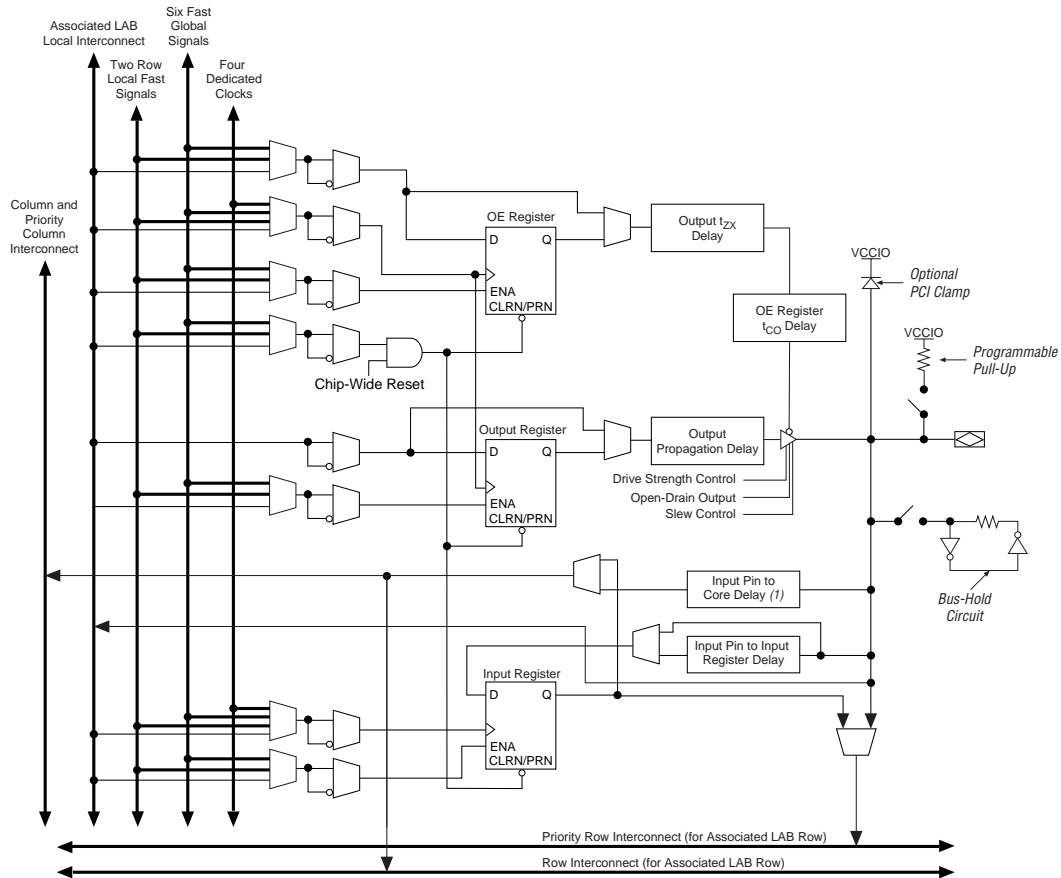

**Note to Figure 26:**

- (1) This programmable delay has four settings: off and three levels of delay.

### Double Data Rate I/O

Mercury device's have three register IOEs to support the DDRIO feature, which makes double data rate interfaces possible by clocking data on both positive and negative clock edges. The IOE in Mercury devices supports double data rate input and double data rate output modes.

In Mercury device IOEs, the OE register is a multi-purpose register available as a second input or output register. When using the IOE for double data rate inputs, the input register and OE register are automatically configured as input registers to clock input double rate data on alternating edges. An input latch is also used within the IOE for DDR input acquisition. The latch holds the data that is present during the clock high times, driving it to the OE register. This allows the OE register and input register to clock both bits of data into LEs, synchronous to the same clock edge (either rising or falling). Figure 27 shows an IOE configured for DDR input.

Figure 27. IOE Configured for DDR Input

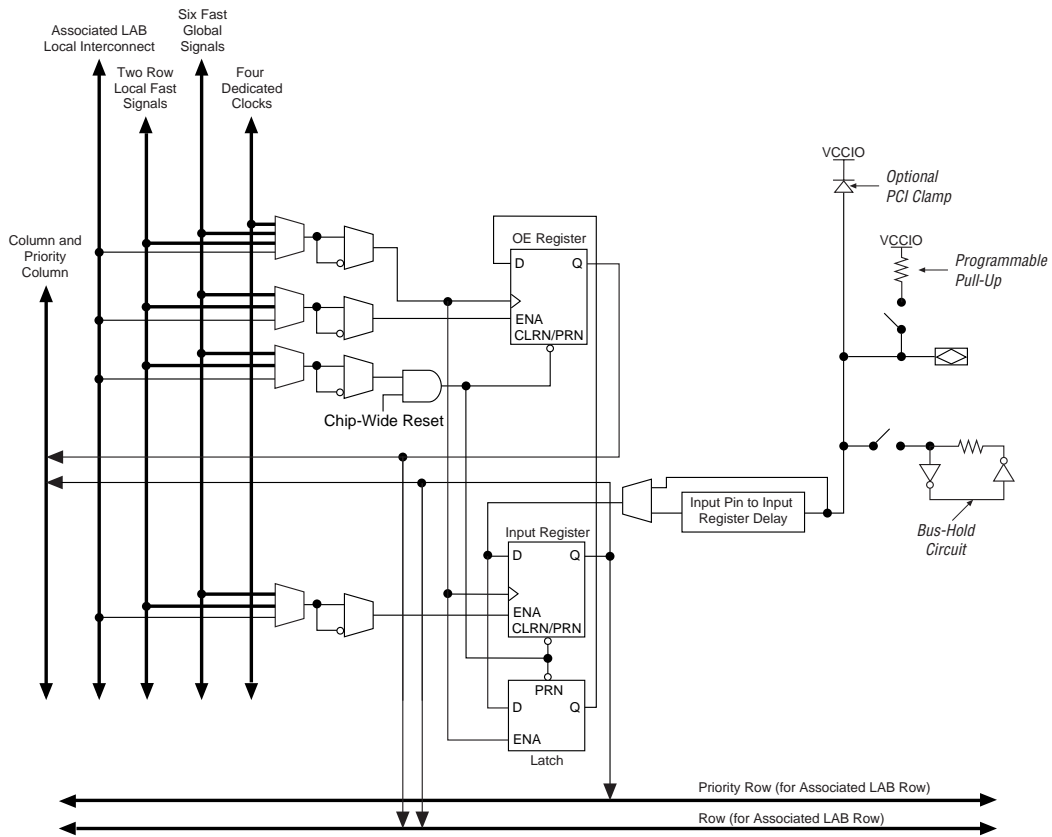

When using the IOE for double data rate outputs, the output register and OE register are automatically configured to clock two data paths from LEs on rising clock edges. These register outputs are multiplexed by the clock to drive the output pin at a  $\times 2$  rate. The output register clocks the first bit out on the clock high time, while the OE register clocks the second bit out on the clock low time. Figure 28 shows the IOE configured for DDR output.

Figure 28. IOE Configured for DDR Output

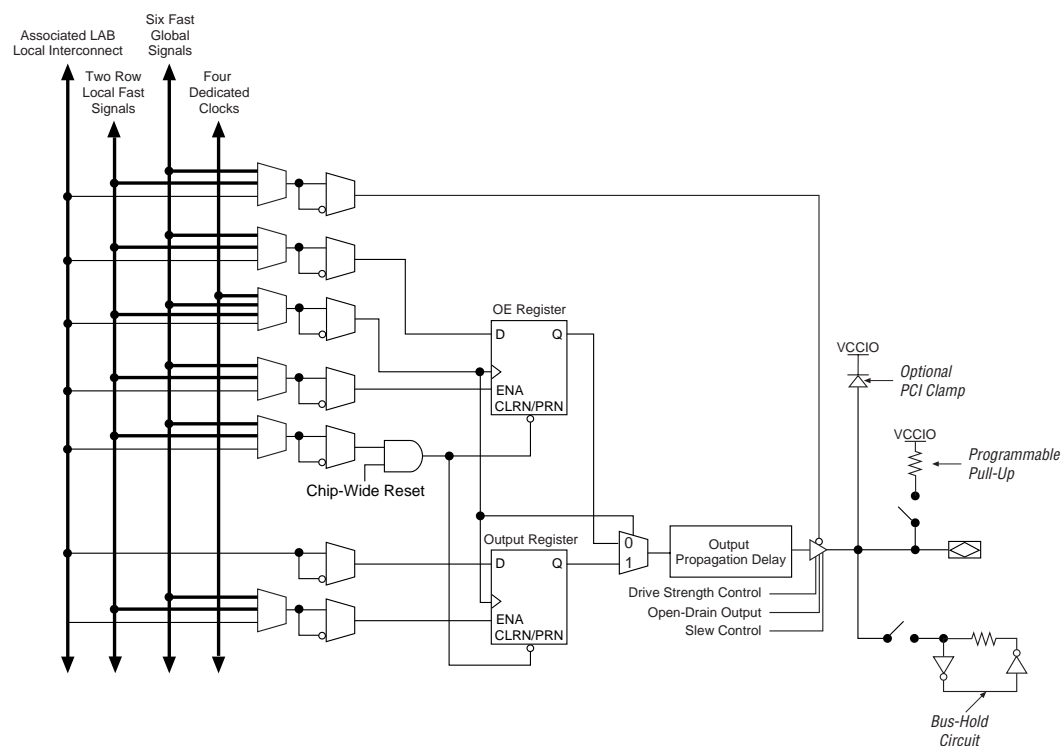

Bidirectional DDR on an I/O pin is possible by using the IOE for DDR output and using LEs to acquire the double data rate input. Bidirectional DDR I/O pins support double data rate synchronous DRAM (DDR SDRAM) at 166 MHz (334 Mbps), which transfer data on a double data rate bidirectional bus. QDR SRAMs are also supported with DDR I/O pins on separate read and write ports.

## Zero Bus Turnaround SRAM Interface Support

In addition to DDR SDRAM support, Mercury device I/O pins also support interfacing with ZBT SRAM blocks at up to 200 MHz. ZBT SRAM blocks are designed to eliminate dead bus cycles when turning a bidirectional bus around between reads and writes, or writes and reads. ZBT allows for 100% bus utilization because ZBT SRAM can read or write on every clock cycle.

To avoid bus contention, the output  $t_{ZX}$  delay ensures that the clock-to-low-impedance time ( $t_{ZX}$ ) is greater than the clock-to-high-impedance time ( $t_{XZ}$ ). Time delay control of clocks to the OE/output and input register, using a single general purpose PLL, enable the Mercury device to meet ZBT  $t_{CO}$  and  $t_{SU}$  times.

## Programmable Drive Strength

The output buffer for each Mercury device I/O pin has a programmable drive strength control for certain I/O standards. The LVTTTL standard has several levels of drive strength that can be controlled by the user. SSTL-3 class I and II, SSTL-2 class I and II, HSTL class I and II, and 3.3-V GTL+ support a minimum or maximum setting. The minimum setting is the lowest drive strength that guarantees the  $I_{OH}/I_{OL}$  of the standard. The maximum setting provides higher drive strength that allows for faster switching and is the default setting. Using settings below the maximum provides signal slew-rate control to reduce system noise and signal overshoot. [Table 11](#) shows the possible settings for the I/O standards with drive strength control.

<i>Table 11. Programmable Drive Strength</i>	
I/O Standard	$I_{OH}/I_{OL}$ Current Strength Setting
LVTTTL (3.3 V)	4 mA
	8 mA
	12 mA
	16 mA
	24 mA (default)
LVTTTL (2.5 V)	4 mA
	8 mA
	12 mA
	16 mA (default)
LVTTTL (1.8 V)	2 mA
	4 mA (default)
SSTL-3 class I and II SSTL-2 class I and II HSTL class I and II GTL+ (3.3 V)	Minimum
	Maximum (default)

### Open-Drain Output

Mercury devices provide an optional open-drain (equivalent to an open-collector) output for each I/O pin. This open-drain output enables the device to provide system-level control signals (e.g., interrupt and write enable signals) that can be asserted by any of several devices.

### Slew-Rate Control

The output buffer for each Mercury device I/O pin has a programmable output slew rate control that can be configured for low-noise or high-speed performance. A faster slew rate provides high-speed transitions for high-performance systems. However, these fast transitions may introduce noise transients into the system. A slow slew rate reduces system noise, but adds a nominal delay to rising and falling edges. Each I/O pin has an individual slew rate control, allowing the designer to specify the slew rate on a pin-by-pin basis. The slew rate control affects both the rising and falling edges.

## Bus Hold

Each Mercury device I/O pin provides an optional bus-hold feature. When this feature is enabled for an I/O pin, the bus-hold circuitry weakly holds the signal at its last driven state. By holding the last driven state of the pin until the next input signal is present, the bus-hold feature eliminates the need to add external pull-up or pull-down resistors to hold a signal level when the bus is tri-stated. The bus-hold circuitry also pulls undriven pins away from the input threshold voltage where noise can cause unintended high-frequency switching. This feature can be selected individually for each I/O pin. The bus-hold output will drive no higher than  $V_{CCIO}$  to prevent overdriving signals. If the bus-hold feature is enabled, the programmable pull-up option cannot be used. The bus-hold feature should also be disabled if open-drain outputs are used with the GTL+ I/O standard.

The bus-hold circuitry weakly pulls the signal level to the last driven state through a resistor with a nominal resistance ( $R_{BH}$ ) of approximately 8 k $\Omega$ . [Table 42](#) gives specific sustaining current that will be driven through this resistor and overdrive current that will identify the next driven input level. This information is provided for each  $V_{CCIO}$  voltage level.

The bus-hold circuitry is active only after configuration. When going into user mode, the bus-hold circuit captures the value on the pin present at the end of configuration.

## Programmable Pull-Up Resistor

Each Mercury device I/O pin provides an optional programmable pull-up resistor during user mode. When this feature is enabled for an I/O pin, the pull-up resistor (50 k $\Omega$ ) weakly holds the output to the  $V_{CCIO}$  level of the bank that the output pin resides in.

## I/O Row Bands

The I/O row bands are one of the advanced features of the Mercury architecture. All IOEs are grouped in I/O row bands across the device. The number of I/O row bands depends on the Mercury device size. The I/O row bands are designed for flip-chip technology, allowing I/O pins to be distributed across the entire chip, not only in the periphery. This array driver technology allows higher I/O pin density (I/O pins per device area) than peripheral I/O pins.

Each row of I/O pins has an associated LAB row for driving to and from the core of the Mercury device. For a given I/O band row, its associated LAB row is located below it with the exception of the bottom I/O band row. The bottom I/O band is located at the bottom periphery of the device, hence its associated LAB row is located above it. Figure 29 shows an example of an I/O band to associated LAB row interconnect in a Mercury device.

There is a maximum of two IOEs associated with each LAB in the associated LAB row. The local interconnect of the associated LAB drives the IOEs. Since local interconnect is shared with the LAB neighbor, any given LAB can directly drive up to four IOEs. The local interconnect drives the data and OE signals when the IOE is used as an output or bidirectional pin.

Figure 29. IOE Connection to Interconnects and Adjacent LAB Note (1)

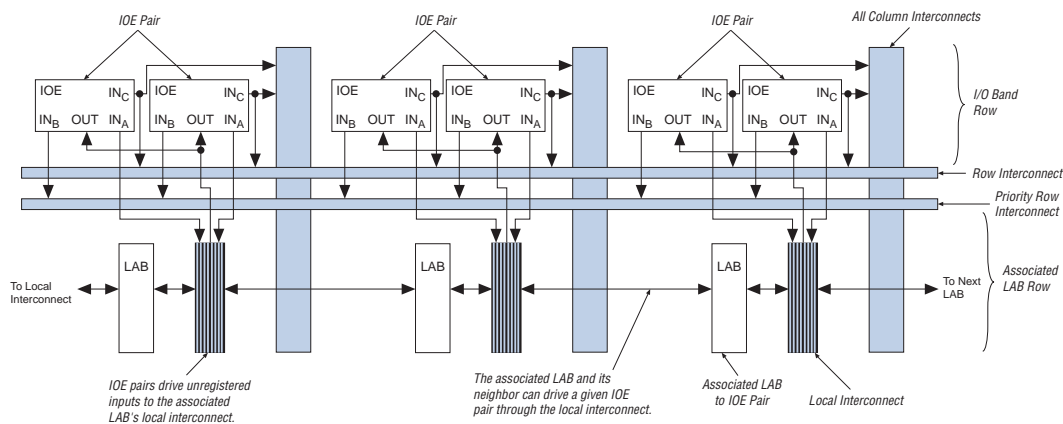

**Note to Figure 29:**

- (1) IN<sub>A</sub>: unregistered input; IN<sub>B</sub>: registered/unregistered input; IN<sub>C</sub>: registered/unregistered input or OE register output in DDR mode.

The IOEs drive registered or combinatorial versions of input data into the device. The unregistered input data can be driven to the local interconnect (for fast input setup), row and priority row interconnect, and column and priority column interconnects. The registered data can also be driven to the same row and column resources. The OE register output can be fed back through column and row interconnects to implement DDR I/O pins.

## Dedicated Fast Lines & I/O Pins

Mercury devices incorporate dedicated bidirectional pins for signals with high internal fanout, such as PCI control signals. These pins are called dedicated fast I/O pins (FAST1, FAST2, FAST3, FAST4, FAST5, and FAST6) and can drive the six global fast lines throughout the device, ideal for fast clock, clock enable, clear, preset, or high fanout logic signal distribution. The dedicated fast I/O pins have the same IOE as a regular I/O pin. The dedicated fast lines can also be driven by a LE local interconnect to generate internal global signals.

In addition to the device global fast lines, each LAB row has two dedicated fast lines local to the row. This is ideal for high fanout control signals for a section of a design that may fit into a single LAB row. Each I/O band (with the exception of the top I/O band) has two dedicated row-global fast I/O pins to drive the row-global fast resources for the associated LAB. The dedicated local fast I/O pins have the same IOE as a regular I/O pin. The LE local interconnect can drive dedicated row-global fast lines to generate internal global signals specific to a row. There are no pin connections for buried LAB rows; LE local interconnects drive the row-global signals in those rows.

## I/O Standard Support

Mercury device IOEs support the following I/O standards:

- LVTTTL
- LVCMOS
- 1.8-V
- 2.5-V
- 3.3-V PCI
- 3.3-V PCI-X
- 3.3-V AGP (1×, 2×)
- LVDS
- LVPECL
- 3.3-V PCML
- GTL+
- HSTL class I and II
- SSTL-3 class I and II
- SSTL-2 class I and II
- CTT

Table 12 describes the I/O standards supported by Mercury devices.

I/O Standard	Type	Input Reference Voltage ( $V_{REF}$ ) (V)	Output Supply Voltage ( $V_{CCIO}$ ) (V)	Board Termination Voltage ( $V_{TT}$ ) (V)
LVTTTL	Single-ended	N/A	3.3	N/A
LVC MOS	Single-ended	N/A	3.3	N/A
2.5 V	Single-ended	N/A	2.5	N/A
1.8 V	Single-ended	N/A	1.8	N/A
3.3-V PCI	Single-ended	N/A	3.3	N/A
3.3-V PCI-X	Single-ended	N/A	3.3	N/A
LVDS	Differential	N/A	3.3	N/A
LVPECL	Differential	N/A	3.3	N/A
3.3-V PCML	Differential	N/A	3.3	3.3
GTL+	Voltage referenced	1.0	N/A	1.5
HSTL class I and II	Voltage referenced	0.75	1.5	0.75
SSTL-2 class I and II	Voltage referenced	1.25	2.5	1.25
SSTL-3 class I and II	Voltage referenced	1.5	3.3	1.5
AGP	Voltage referenced	1.32	3.3	N/A
CTT	Voltage referenced	1.5	3.3	1.5

Each regular I/O band row contains two I/O banks. The number of I/O banks in a Mercury device depends on the number of I/O band rows. The top I/O band contains four regular I/O banks specifically designed for HSDI. The top I/O band banks and dedicated clock inputs support LVDS, LVPECL, and 3.3-V PCML. 3.3-V PCML is an open-drain standard and therefore requires external termination to 3.3 V. All other standards are supported by all I/O banks. The top I/O banks 1, 2, 3, and 4 only support non-HSDI I/O pins if the design does not use HSDI circuitry. If the design uses any HSDI channel, banks 1, 2, 3, and 4 all do not support regular I/O pins.

Additionally, the EP1M350 device includes the Flexible-LVDS feature, providing support for up to 100 LVDS channels on all regular I/O banks. Regular I/O banks in EP1M350 devices include dedicated LVDS input and output buffers that do not require any external components except for 100- $\Omega$  termination resistors on receiver channels.

For the HSDI I/O band, half of the dedicated banks support LVDS, 3.3-V PCML or LVPECL, and receiver inputs, while the other half support LVDS, PCML or LVPECL, and transmitter outputs. A single device can support 1.5-V, 1.8-V, 2.5-V, and 3.3-V interfaces; each bank can support a  $V_{CCIO}$  standard independently. Each bank can also use a separate  $V_{REF}$  level so that each bank can support any of the terminated standards (such as SSTL-3) independently. A bank can support a single  $V_{REF}$  level. Each bank contains a fixed  $V_{REF}$  pin for voltage referenced standards. This pin can be used as a regular I/O if a  $V_{REF}$  standard is not used. Table 13 shows the number of I/O banks in each Mercury device.

<i>Table 13. Number of I/O Banks per Device</i>		
Device	Regular I/O Banks	HSDI Band I/O Banks
EP1M120	8	4
EP1M350	12	4

Each bank can support multiple standards with the same  $V_{CCIO}$  for output pins. For EP1M120 devices, each bank can support one voltage-referenced I/O standard, but can support multiple I/O standards with the same  $V_{CCIO}$  and  $V_{REF}$  voltage levels. For example, when  $V_{CCIO}$  is 3.3 V, a bank can support LVTTTL, LVCMOS, 3.3-V PCI, and SSTL-3 for inputs and outputs. Figure 30 shows the I/O bank layout for an EP1M120 device. For EP1M350 devices, each bank can support two voltage-referenced I/O standards; each I/O bank is split into two voltage-referenced sub-banks. When using the two HSDI transmitter banks as regular I/O banks in a non-HSDI mode, those two banks require the same  $V_{CCIO}$  level. However, each HSDI transmitter bank supports its own  $V_{REF}$  level.

Figure 30. I/O Bank Layout

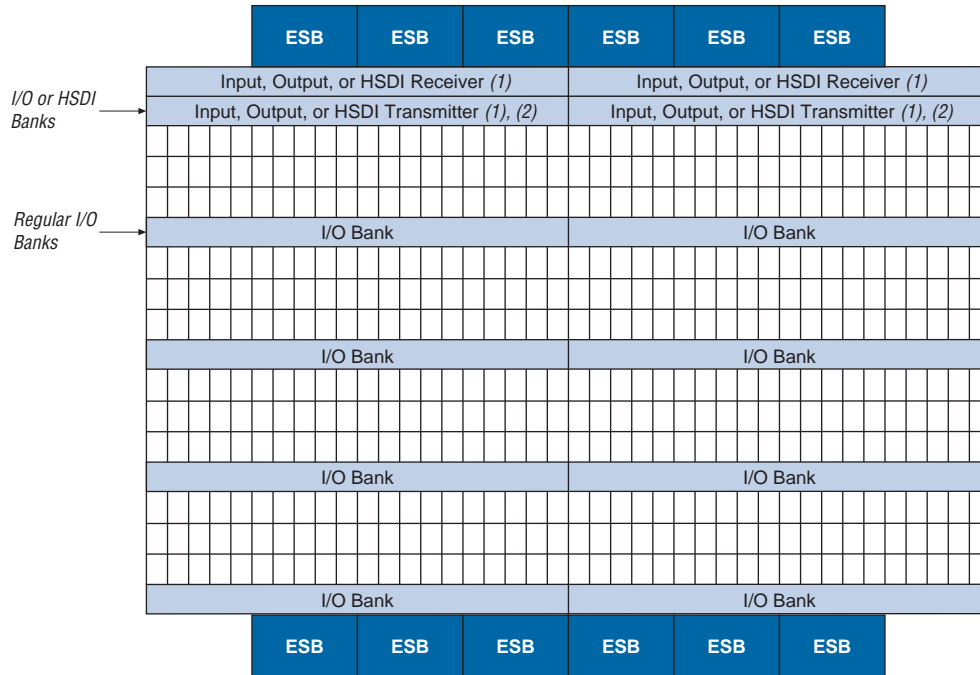

**Notes to Figure 30:**

- (1) If HSDI I/O channels are not used, the HSDI banks can be used as regular I/O banks.
- (2) When used as regular I/O banks, these banks must be set to the same  $V_{CCIO}$  level, but can have separate  $V_{REF}$  bank settings.



For more information on I/O standards, see [Application Note 117 \(Using Selectable I/O Standards in Altera Devices\)](#).

**MultiVolt I/O Interface**

The Mercury architecture supports the MultiVolt I/O interface feature, which allows Mercury devices in all packages to interface with devices with different supply voltages. The devices have one set of VCC pins for internal operation and input buffers (VCCINT), and another set for I/O output drivers (VCCIO).

The Mercury  $V_{CCINT}$  pins must always be connected to a 1.8-V power supply. With a 1.8-V  $V_{CCINT}$  level, input pins are 1.8-V, 2.5-V and 3.3-V tolerant. The  $V_{CCIO}$  pins can be connected to either a 1.5-V, 1.8-V, 2.5-V or 3.3-V power supply, depending on the output requirements. When  $V_{CCIO}$  pins are connected to a 1.5-V power supply, the output levels are compatible with HSTL systems. When  $V_{CCIO}$  pins are connected to a 1.8-V power supply, the output levels are compatible with 1.8-V systems. When  $V_{CCIO}$  pins are connected to a 2.5-V power supply, the output levels are compatible with 2.5-V systems. When the  $V_{CCIO}$  pins are connected to a 3.3-V power supply, the output high is 3.3 V and is compatible with 3.3-V or 5.0-V systems.

Table 14 summarizes Mercury MultiVolt I/O support.

*Table 14. Mercury MultiVolt I/O Support*    *Note (1)*

$V_{CCIO}$ (V)	Input Signal					Output Signal				
	1.5 V	1.8 V	2.5 V	3.3 V	5.0 V	1.5 V	1.8 V	2.5 V	3.3 V	5.0 V
1.5	✓	✓	✓	✓		✓				
1.8	✓ (2)	✓	✓	✓			✓ (3)			
2.5	✓ (2)	✓ (2)	✓	✓			✓ (4)	✓		
3.3	✓ (2)	✓ (2)	✓ (2)	✓	✓ (6)			✓ (5)	✓	✓

**Notes to Table 14:**

- (1) The PCI clamping diode must be disabled to drive an input with voltages higher than  $V_{CCIO}$  unless an external resistor is used.
- (2) These input levels are only available if the input standard is set to any  $V_{REF}$ -based input standard (SSTL-2, SSTL-3, HSTL, GTL+, AGP 2x). The input buffers are powered from  $V_{CCINT}$  when using  $V_{REF}$ -based input standards. LVTTTL, PCI, PCI-X, AGP 1x input buffers are powered by  $V_{CCIO}$ . Therefore, these standards cannot be driven with input levels below the  $V_{CCIO}$  setting except for when  $V_{CCIO} = 3.3$  V and the input voltage ( $V_I$ ) = 2.5 V.
- (3) When  $V_{CCIO} = 1.8$  V, the Mercury device can drive a 1.5-V device with 1.8-V tolerant inputs.
- (4) When  $V_{CCIO} = 2.5$  V, the Mercury device can drive a 1.8-V device with 2.5-V tolerant inputs.
- (5) When  $V_{CCIO} = 3.3$  V, the Mercury device can drive a 2.5-V device with 3.3-V tolerant inputs.
- (6) Designers can set Mercury devices to be 5.0-V tolerant by adding an external resistor and enabling the PCI clamping diode.

**Power Sequencing & Hot-Socketing**

Because Mercury devices can be used in a mixed-voltage environment, the devices are designed specifically to tolerate any possible power-up sequence. Therefore, the  $V_{CCIO}$  and  $V_{CCINT}$  power supplies may be powered in any order.

Signals can be driven into Mercury devices before and during power-up without damaging the device. In addition, Mercury devices do not drive out during power-up. Once operating conditions are reached and the device is configured, Mercury devices operate as specified by the user.

## General Purpose PLL

Mercury devices have ClockLock™, ClockBoost™, and advanced ClockShift™ features, which use up to four general-purpose PLLs (separate from the two HSDI PLLs) to provide clock management and clock-frequency synthesis. EP1M120 devices contain two general purpose PLLs; EP1M350 devices contain four general purpose PLLs. These PLLs allow designers to increase performance and provide clock-frequency synthesis. The PLL reduces the clock delay within a device. This reduction minimizes clock-to-output and setup times while maintaining zero hold times. The PLLs, which provide programmable multiplication, allow the designer to distribute a low-speed clock and multiply that clock on-device. Mercury devices include a high-speed clock tree: unlike ASICs, the user does not have to design and optimize the clock tree. The PLLs work in conjunction with the Mercury device's high-speed clock to provide significant improvements in system performance and bandwidth. [Table 15](#) shows the general purpose PLL features for Mercury devices. [Figure 31](#) shows a Mercury PLL.

Device	Number of PLLs	ClockBoost Feature (1)	Number of External Clock Outputs	Number of Feedback Inputs	Advanced ClockShift
EP1M120	2	$m/(n \times k, p, q, v)$	2	2	✓
EP1M350	4	$m/(n \times k, p, q, v)$	4	4	✓

**Note to Table 15:**

- (1)  $n$  represents the prescale divider for the PLL input.  $k, p, q,$  and  $v$  represent the different post scale dividers for the four possible PLL outputs.  $m, k, p,$  and  $q$  are integers that range from 1 to 160.  $n$  and  $v$  are integers that can range from 1 to 16.

Figure 31. Mercury General-Purpose PLL

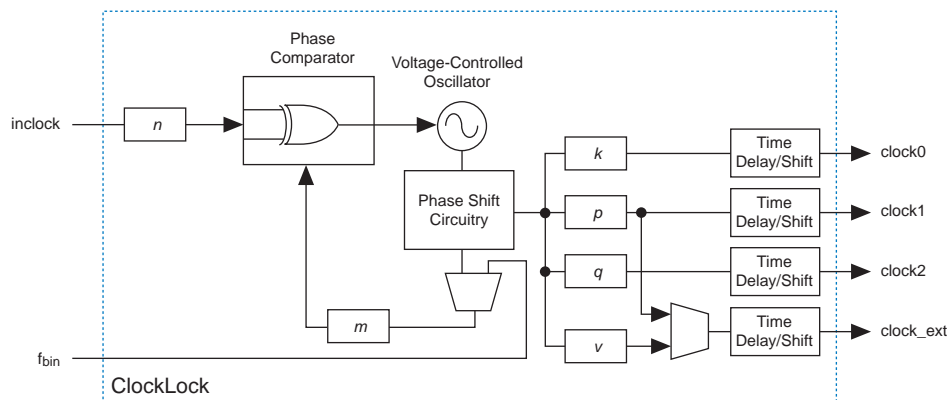

The PLLs in Mercury devices are enabled through the Quartus II software. External devices are not required to use these features.

### Advanced ClockBoost Multiplication & Division

Each Mercury PLL includes circuitry that provides clock synthesis for up to four outputs (three internal outputs and one external output) using  $m/(n \times \text{output divider})$  scaling. When a PLL is locked, the locked output clock aligns to the rising edge of the input clock. The closed loop equation for [Figure 31](#) gives an output frequency  $f_{\text{clock0}} = (m/(n \times k))f_{\text{IN}}$ ,  $f_{\text{clock1}} = (m/(n \times p))f_{\text{IN}}$ ,  $f_{\text{clock2}} = (m/(n \times q))f_{\text{IN}}$ , and  $f_{\text{clock_ext}} = (m/(n \times v))f_{\text{IN}}$  or  $f_{\text{clock1}}$ . These equations allow the multiplication or division of clocks by a programmable number. The Quartus II software automatically chooses the appropriate scaling factors according to the frequency, multiplication, and division values entered.

A single PLL in a Mercury device allows for multiple user-defined multiplication and division ratios that are not possible even with multiple delay-locked loops (DLLs). For example, if a frequency scaling factor of 3.75 is needed for a given input clock, a multiplication factor of 15 and a division factor of 4 can be entered. This advanced multiplication scaling can be performed with a single PLL, making it unnecessary to cascade PLL outputs.

### External Clock Outputs

Mercury devices have four low-jitter external clocks available for external clock sources. Other devices on the board can use these outputs as clock sources.

There are three modes for external clock outputs. Multiplication is allowed in all external clock output modes.

- **Zero Delay Buffer:** The external clock output pin is phase aligned with the clock input pin for zero delay. Programmable phase shift and time delay shift are not allowed in this configuration. Multiplication is allowed with the zero delay buffer mode. The MegaWizard interface for `altclklock` should be used to verify possible clock settings.
- **External Feedback:** The external feedback input pin is phase aligned with clock input pin. By aligning these clocks, you can actively remove clock delay and skew between devices. Multiplication is allowed with the external feedback mode. This mode has the same restrictions as zero delay buffer mode.

- Normal Mode: The external clock output pin will have phase delay relative to the clock input pin. If an internal clock is used in this mode, the IOE register clock will be phase aligned to the input clock pin. Multiplication is allowed with the normal mode.

### Advanced ClockShift Circuitry

General purpose PLLs in Mercury devices have advanced ClockShift™ circuitry that provides programmable phase shift and fine tune time delay shift. For phase shifting, users can enter a phase shift (in degrees or time units) that affects all PLL outputs. Phase shifts of 90, 180, and 270 can be implemented exactly. Other values of phase shifting, or delay shifting in time units, are allowed with a resolution range of 0.3 ns to 1.0 ns. This resolution varies with frequency input and the user-entered multiplication and division factors. The phase shift ability is only possible on a multiplied or divided clock if the input and output frequency have an integer multiple relationship (i.e.,  $f_{IN}/f_{OUT}$  or  $f_{OUT}/f_{IN}$  must be an integer).

In addition to the phase shift feature that affects all outputs, there is an advanced fine time delay shift control on each of the four PLL outputs. Each PLL output can be shifted in 250-ps increments for a range of -2.0 ns to +2.0 ns. This ability can be used in conjunction with the phase shifting ability that affects all outputs.  $f_{IN}/f_{OUT}$  does not need to have an integer relationship for the advanced fine time delay shift control.

### Clock Enable Signal

Mercury PLLs have a `CLKLK_ENA` pin for enabling/disabling all of the device PLLs. When the `CLKLK_ENA` pin is high, the PLL drives a clock to all its output ports. When the `CLKLK_ENA` pin is low, the `clock0`, `clock1`, `clock2` and `extclock` ports are driven by GND and all of the PLLs go out of lock. When the `CLKLK_ENA` pin goes high again, the PLL must relock.

The individual enable port for each general purpose PLL is programmable. If more than one general-purpose PLL is instantiated, each one does not have to use the clock enable. To enable/disable the device PLLs with the `CLKLK_ENA` pin, the `inclocken` port on the `altclock` instance must be connected to the `CLKLK_ENA` input pin.

## Lock Signals

The Mercury device general purpose PLL circuits support individual LOCK signals. The LOCK signal drives high when the PLL has locked onto the input clock. Lock remains high as long as the input remains within specification. It will go low if the input is out of specification. A LOCK pin is optional for each PLL used in the Mercury devices; when not used, they are I/O pins. This signal is not available internally; if it is used in the core, it must be fed back in with an input pin.

## SignalTap Embedded Logic Analyzer

Mercury devices include device enhancements to support the SignalTap embedded logic analyzer. By including this circuitry, the Mercury device provides the ability to monitor design operation over a period of time through the IEEE Std. 1149.1 JTAG circuitry; a designer can analyze internal logic at speed without bringing internal signals to the I/O pins. This feature is particularly important for advanced packages such as FineLine BGA packages, because it can be difficult to add a connection to a pin during the debugging process after a board is designed and manufactured.

## IEEE Std. 1149.1 (JTAG) Boundary-Scan Support

All Mercury devices provide JTAG BST circuitry that complies with the IEEE Std. 1149.1-1990 specification. JTAG boundary-scan testing can be performed before or after configuration, but not during configuration. Mercury devices can also use the JTAG port for configuration with the Quartus II software or with hardware using either Jam Standard Test and Programming Language (STAPL) Files (**.jam**) or Jam STAPL Byte-Code Files (**.jbc**). Mercury devices also use the JTAG port to monitor the logic operation of the device with the SignalTap embedded logic analyzer. Mercury devices support the JTAG instructions shown in [Table 16](#).

JTAG Instruction	Description
SAMPLE/PRELOAD	Allows a snapshot of signals at the device pins to be captured and examined during normal device operation and permits an initial data pattern to be output at the device pins. Also used by the SignalTap embedded logic analyzer.
EXTEST	Allows the external circuitry and board-level interconnections to be tested by forcing a test pattern at the output pins and capturing test results at the input pins.
BYPASS	Places the 1-bit bypass register between the TDI and TDO pins, which allows the BST data to pass synchronously through selected devices to adjacent devices during normal device operation.
USERCODE	Selects the 32-bit USERCODE register and places it between the TDI and TDO pins, allowing the USERCODE to be serially shifted out of TDO.
IDCODE	Selects the IDCODE register and places it between TDI and TDO, allowing the IDCODE to be serially shifted out of TDO.
ICR Instructions	These instructions are used when configuring a Mercury device via the JTAG port with a ByteBlasterMV™ download cable, or using a Jam STAPL or Jam Byte-Code file via an embedded processor.
SignalTap Instructions	These instructions monitor internal device operation with the SignalTap embedded logic analyzer.

The Mercury device instruction register length is 10 bits. The Mercury device USERCODE register length is 32 bits. Tables 17 and 18 show the boundary-scan register length and device IDCODE information for Mercury devices.

Device	Boundary-Scan Register Length (Bits)
EP1M120	1,125
EP1M350	1,695

Device	IDCODE (32 Bits) (1)			
	Version (4 Bits)	Part Number (16 Bits)	Manufacturer Identity (11 Bits)	1 (1 Bit) (2)
EP1M120	0000	0011 0000 0000 0000	000 0110 1110	1
EP1M350	0000	0011 0000 0000 0001	000 0110 1110	1

**Notes to Table 18:**

- (1) The most significant bit (MSB) is on the left.
- (2) The IDCODE's least significant bit (LSB) is always 1.

Figure 32 shows the timing requirements for the JTAG signals.

Figure 32. Mercury JTAG Waveforms

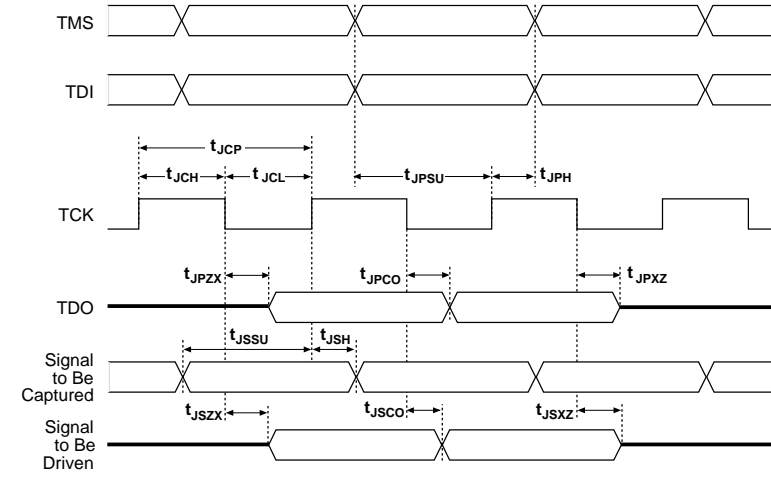

Table 19 shows the JTAG timing parameters and values for Mercury devices.

Symbol	Parameter	Min	Max	Unit
$t_{JCP}$	TCK clock period	100		ns
$t_{JCH}$	TCK clock high time	50		ns
$t_{JCL}$	TCK clock low time	50		ns
$t_{JPSU}$	JTAG port setup time	20		ns
$t_{JPH}$	JTAG port hold time	45		ns
$t_{JPCO}$	JTAG port clock to output		25	ns
$t_{JPZX}$	JTAG port high impedance to valid output		25	ns
$t_{JPXZ}$	JTAG port valid output to high impedance		25	ns
$t_{JSSU}$	Capture register setup time	20		ns
$t_{JSH}$	Capture register hold time	45		ns
$t_{JSCO}$	Update register clock to output		35	ns
$t_{JSZX}$	Update register high impedance to valid output		35	ns
$t_{JSXZ}$	Update register valid output to high impedance		35	ns



For more information, see the following documents:

- [Application Note 39 \(IEEE Std. 1149.1 \(JTAG\) Boundary-Scan Testing in Altera Devices\)](#)
- Jam Programming & Test Language Specification

## Generic Testing

Each Mercury device is functionally tested. Complete testing of each configurable static random access memory (SRAM) bit and all logic functionality ensures 100% yield. AC test measurements for Mercury devices are made under conditions equivalent to those shown in [Figure 33](#). Multiple test patterns can be used to configure devices during all stages of the production flow.

**Figure 33. Mercury AC Test Conditions**

Power supply transients can affect AC measurements. Simultaneous transitions of multiple outputs should be avoided for accurate measurement. Threshold tests must not be performed under AC conditions. Large-amplitude, fast-ground-current transients normally occur as the device outputs discharge the load capacitances. When these transients flow through the parasitic inductance between the device ground pin and the test system ground, significant reductions in observable noise immunity can result.

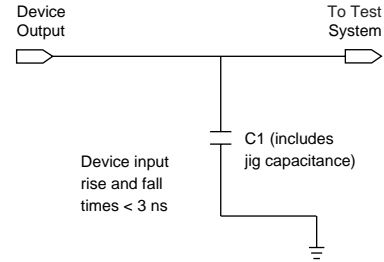

## Operating Conditions

Table 20 through 43 provide information on absolute maximum ratings, recommended operating conditions, DC operating conditions, and capacitance for 1.8-V Mercury devices.

Symbol	Parameter	Conditions	Minimum	Maximum	Unit
$V_{CCINT}$	Supply voltage	With respect to ground (2)	-0.5	2.5	V
$V_{CCIO}$			-0.5	4.6	V
$V_I$	DC input voltage		-0.5	4.6	V
$I_{OUT}$	DC output current, per pin		-34	34	mA
$T_{STG}$	Storage temperature	No bias	-65	150	° C
$T_{AMB}$	Ambient temperature	Under bias	-65	135	° C
$T_J$	Junction temperature	BGA packages under bias		135	° C

Symbol	Parameter	Conditions	Minimum	Maximum	Unit
$V_{CCINT}$	Supply voltage for internal logic and input buffers	(3)	1.71	1.89	V
$V_{CCIO}$	Supply voltage for output buffers, 3.3-V operation	(3), (4)	3.00 (3.135)	3.60 (3.465)	V
	Supply voltage for output buffers, 2.5-V operation	(3)	2.375	2.625	V
	Supply voltage for output buffers, 1.8-V operation	(3)	1.71	1.89	V
	Supply voltage for output buffers, 1.5-V operation	(3)	1.4	1.6	V
$V_I$	Input voltage	(2), (5)	-0.5	4.1	V
$V_O$	Output voltage		0	$V_{CCIO}$	V
$T_J$	Operating temperature	For commercial use	0	85	°C
		For industrial use	-40	100	°C
$t_R$	Input rise time			40	ns
$t_F$	Input fall time			40	ns

Symbol	Parameter	Conditions	Minimum	Typical	Maximum	Unit	
$I_I$	Input pin leakage current	$V_I = V_{CCIOmax}$ to 0 V (5)	-10		10	μA	
$I_{OZ}$	Tri-stated I/O pin leakage current	$V_O = V_{CCIOmax}$ to 0 V (5)	-10		10	μA	
$I_{CC0}$	$V_{CC}$ supply current (standby) for EP1M120 devices	For commercial use (8)		30		mA	
		For Industrial use (8)		40		mA	
	$V_{CC}$ supply current (standby) for EP1M350 devices	For commercial use (8)			50		mA
		For Industrial use (8)			60		mA
$R_{CONF}$	Value of I/O pin pull-up resistor before and during configuration	$V_{CCIO} = 3.0$ V (9)	20		50	kΩ	
		$V_{CCIO} = 2.375$ V (9)	30		80	kΩ	
		$V_{CCIO} = 1.71$ V (9)	60		150	kΩ	

**Table 23. LVTTTL Specifications** *Note (10)*

Symbol	Parameter	Conditions	Minimum	Maximum	Units
$V_{CCIO}$	Output supply voltage		3.0	3.6	V
$V_{IH}$	High-level input voltage		1.7	4.1	V
$V_{IL}$	Low-level input voltage		-0.5	0.7	V
$I_I$	Input pin leakage current	$V_{IN} = 0\text{ V or }V_{CCIO}$	-10	10	$\mu\text{A}$
$V_{OH}$	High-level output voltage	$I_{OH} = -4\text{ mA}$	2.4		V
$V_{OL}$	Low-level output voltage	$I_{OL} = 4\text{ mA}$		0.45	V

**Table 24. LVCMOS Specifications**

Symbol	Parameter	Conditions	Minimum	Maximum	Units
$V_{CCIO}$	Power supply voltage range		3.0	3.6	V
$V_{IH}$	High-level input voltage		1.7	4.1	V
$V_{IL}$	Low-level input voltage		-0.5	0.7	V
$I_I$	Input pin leakage current	$V_{IN} = 0\text{ V or }V_{CCIO}$	-10	10	$\mu\text{A}$
$V_{OH}$	High-level output voltage	$V_{CCIO} = 3.0,$ $I_{OH} = -0.1\text{ mA}$	$V_{CCIO} - 0.2$		V
$V_{OL}$	Low-level output voltage	$V_{CCIO} = 3.0,$ $I_{OL} = 0.1\text{ mA}$		0.2	V

**Table 25. 2.5-V I/O Specifications** *Note (10)*

Symbol	Parameter	Conditions	Minimum	Maximum	Units
$V_{CCIO}$	Output supply voltage		2.375	2.625	V
$V_{IH}$	High-level input voltage		1.7	4.1	V
$V_{IL}$	Low-level input voltage		-0.5	0.7	V
$I_I$	Input pin leakage current	$V_{IN} = 0\text{ V or }V_{CCIO}$	10	10	$\mu\text{A}$
$V_{OH}$	High-level output voltage	$I_{OH} = -0.1\text{ mA}$	2.1		V
		$I_{OH} = -1\text{ mA}$	2.0		V
		$I_{OH} = -2\text{ mA}$	1.7		V
$V_{OL}$	Low-level output voltage	$I_{OL} = 0.1\text{ mA}$		0.2	V
		$I_{OH} = 1\text{ mA}$		0.4	V
		$I_{OH} = 2\text{ mA}$		0.7	V

Symbol	Parameter	Conditions	Minimum	Maximum	Units
$V_{CCIO}$	Output supply voltage		1.71	1.89	V
$V_{IH}$	High-level input voltage		$0.65 \times V_{CCIO}$	4.1	V
$V_{IL}$	Low-level input voltage		-0.5	$0.35 \times V_{CCIO}$	V
$I_I$	Input pin leakage current	$V_{IN} = 0 \text{ V or } V_{CCIO}$	-10	10	$\mu\text{A}$
$V_{OH}$	High-level output voltage	$I_{OH} = -2 \text{ mA}$	$V_{CCIO} - 0.45$		V
$V_{OL}$	Low-level output voltage	$I_{OL} = 2 \text{ mA}$		0.45	V

Figures 34 and 35 show receiver input and transmitter output waveforms, respectively, for all differential I/O standards (LVPECL, 3.3-V PCML, LVDS, and HyperTransport technology).

Figure 34. Receiver Input Waveforms for Differential I/O Standards

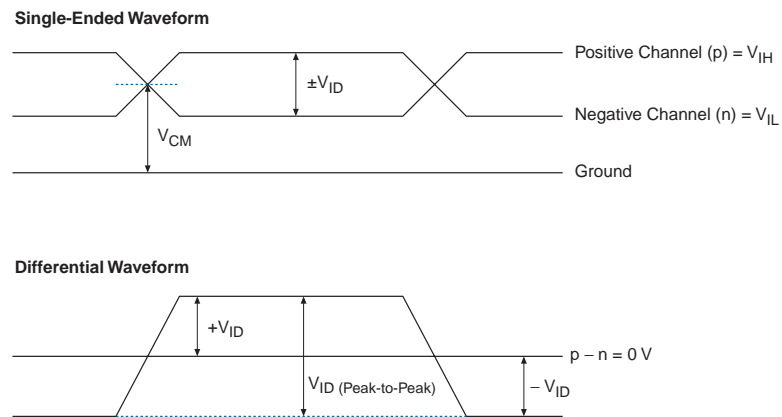
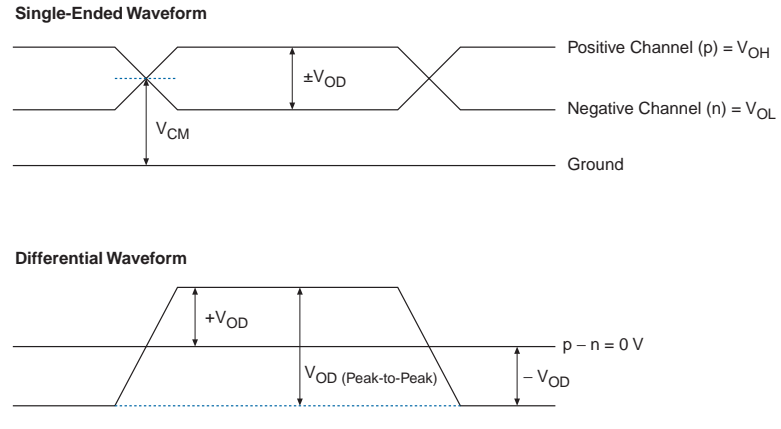

Figure 35. Transmitter Output Waveforms for Differential I/O Standards



Symbol	Parameter	Conditions	Minimum	Typical	Maximum	Units
$V_{CCIO}$	I/O supply voltage		3.135	3.3	3.465	V
$V_{OD}$	Differential output voltage	$R_L = 100\ \Omega$	250	510	600	mV
$\Delta V_{OD}$	Change in $V_{OD}$ between high and low	$R_L = 100\ \Omega$			50	mV
$V_{OS}$	Output offset voltage	$R_L = 100\ \Omega$	1.125	1.25	1.375	V
$\Delta V_{OS}$	Change in $V_{OS}$ between high and low	$R_L = 100\ \Omega$			50	mV
$V_{TH}$	Differential input threshold	$V_{CM} = 1.2\text{ V}$	-100		100	mV
$V_{IN}$	Receiver input voltage range		0.0		2.4	V
$R_L$	Receiver differential input resistor (external to Mercury devices)		90	100	110	$\Omega$

**Table 28. 3.3-V PCML Specifications**

Symbol	Parameter	Conditions	Minimum	Typical	Maximum	Units
V <sub>CCIO</sub>	I/O supply voltage		3.135	3.3	3.465	V
V <sub>IL</sub>	Low-level input voltage				V <sub>CCIO</sub> – 0.4	V
V <sub>IH</sub>	High-level input voltage		V <sub>CCIO</sub>			V
V <sub>OL</sub>	Low-level output voltage				V <sub>CCIO</sub> – 0.4	V
V <sub>OH</sub>	High-level output voltage		V <sub>CCIO</sub>			V
V <sub>T</sub>	Output termination voltage			V <sub>CCIO</sub>		V
V <sub>ID</sub>	Differential input voltage		400		800	mV
V <sub>OD</sub>	Differential output voltage		400	700	800	mV
t <sub>R</sub>	Rise time (20 to 80%)				200	ps
t <sub>F</sub>	Fall time (20 to 80%)				200	ps
t <sub>DSKEW</sub>	Differential skew				25	ps
R <sub>1</sub> (11)	Output load		90	100	110	Ω
R <sub>2</sub> (11)	Receiver differential input resistor		45	50	55	Ω

**Table 29. LVPECL Specifications**

Symbol	Parameter	Conditions	Minimum	Typical	Maximum	Units
V <sub>CCIO</sub>	I/O supply voltage		3.135	3.3	3.465	V
V <sub>IL</sub>	Low-level input voltage		0		2,000	mV
V <sub>IH</sub>	High-level input voltage		400		2,470	mV
V <sub>OL</sub>	Low-level output voltage		1,400		1,650	mV
V <sub>OH</sub>	High-level output voltage		2,275		2,470	mV
V <sub>ID</sub>	Differential input voltage		400	600	1,200	mV
V <sub>OD</sub>	Differential output voltage		525	1,050	1,200	mV
t <sub>R</sub>	Rise time (20 to 80%)		85		325	ps
t <sub>F</sub>	Fall time (20 to 80%)		85		325	ps
t <sub>DSKEW</sub>	Differential skew				25	ps
R <sub>L</sub>	Receiver differential input resistor			100		Ω

**Table 30. 3.3-V PCI Specifications**

Symbol	Parameter	Conditions	Minimum	Typical	Maximum	Units
V <sub>CCIO</sub>	I/O supply voltage		3.0	3.3	3.6	V
V <sub>IH</sub>	High-level input voltage		0.5 × V <sub>CCIO</sub>		V <sub>CCIO</sub> + 0.5	V
V <sub>IL</sub>	Low-level input voltage		-0.5		0.3 × V <sub>CCIO</sub>	V
I <sub>I</sub>	Input pin leakage current	0 < V <sub>IN</sub> < V <sub>CCIO</sub>	-10		10	μA
V <sub>OH</sub>	High-level output voltage	I <sub>OUT</sub> = -500 μA	0.9 × V <sub>CCIO</sub>			V
V <sub>OL</sub>	Low-level output voltage	I <sub>OUT</sub> = 1,500 μA			0.1 × V <sub>CCIO</sub>	V

**Table 31. PCI-X Specifications**

Symbol	Parameter	Conditions	Minimum	Typical	Maximum	Units
V <sub>CCIO</sub>	I/O supply voltage		3.0		3.6	V
V <sub>IH</sub>	High-level input voltage		0.5 × V <sub>CCIO</sub>		V <sub>CCIO</sub> + 0.5	V
V <sub>IL</sub>	Low-level input voltage		-0.5		0.35 × V <sub>CCIO</sub>	V
V <sub>IPU</sub>	Input pull-up voltage		0.7 × V <sub>CCIO</sub>			V
I <sub>IL</sub>	Input leakage current	0 < V <sub>IN</sub> < V <sub>CCIO</sub>	-10		10	μA
V <sub>OH</sub>	High-level output voltage	I <sub>OUT</sub> = -500 μA	0.9 × V <sub>CCIO</sub>			V
V <sub>OL</sub>	Low-level output voltage	I <sub>OUT</sub> = 1,500 μA			0.1 × V <sub>CCIO</sub>	V
L <sub>PIN</sub>	Pin inductance				15	nH

**Table 32. GTL+ I/O Specifications** *Note (10)*

Symbol	Parameter	Conditions	Minimum	Typical	Maximum	Units
V <sub>TT</sub>	Termination voltage		1.35	1.5	1.65	V
V <sub>REF</sub>	Reference voltage		0.88	1.0	1.12	V
V <sub>IH</sub>	High-level input voltage		V <sub>REF</sub> + 0.1			V
V <sub>IL</sub>	Low-level input voltage				V <sub>REF</sub> - 0.1	V
V <sub>OL</sub>	Low-level output voltage	I <sub>OL</sub> = 34 mA			0.65	V

**Table 33. SSTL-2 Class I Specifications** *Note (10)*

Symbol	Parameter	Conditions	Minimum	Typical	Maximum	Units
$V_{CCIO}$	I/O supply voltage		2.375	2.5	2.625	V
$V_{TT}$	Termination voltage		$V_{REF} - 0.04$	$V_{REF}$	$V_{REF} + 0.04$	V
$V_{REF}$	Reference voltage		1.15	1.25	1.35	V
$V_{IH}$	High-level input voltage		$V_{REF} + 0.18$		3.0	V
$V_{IL}$	Low-level input voltage		-0.3		$V_{REF} - 0.18$	V
$V_{OH}$	High-level output voltage	$I_{OH} = -7.6$ mA	$V_{TT} + 0.57$			V
$V_{OL}$	Low-level output voltage	$I_{OL} = 7.6$ mA			$V_{TT} - 0.57$	V

**Table 34. SSTL-2 Class II Specifications** *Note (10)*

Symbol	Parameter	Conditions	Minimum	Typical	Maximum	Units
$V_{CCIO}$	I/O supply voltage		2.3	2.5	2.7	V
$V_{TT}$	Termination voltage		$V_{REF} - 0.04$	$V_{REF}$	$V_{REF} + 0.04$	V
$V_{REF}$	Reference voltage		1.15	1.25	1.35	V
$V_{IH}$	High-level input voltage		$V_{REF} + 0.18$		$V_{CCIO} + 0.3$	V
$V_{IL}$	Low-level input voltage		-0.3		$V_{REF} - 0.18$	V
$V_{OH}$	High-level output voltage	$I_{OH} = -15.2$ mA	$V_{TT} + 0.76$			V
$V_{OL}$	Low-level output voltage	$I_{OL} = 15.2$ mA			$V_{TT} - 0.76$	V

**Table 35. SSTL-3 Class I Specifications** *Note (10)*

Symbol	Parameter	Conditions	Minimum	Typical	Maximum	Units
$V_{CCIO}$	I/O supply voltage		3.0	3.3	3.6	V
$V_{TT}$	Termination voltage		$V_{REF} - 0.05$	$V_{REF}$	$V_{REF} + 0.05$	V
$V_{REF}$	Reference voltage		1.3	1.5	1.7	V
$V_{IH}$	High-level input voltage		$V_{REF} + 0.2$		$V_{CCIO} + 0.3$	V
$V_{IL}$	Low-level input voltage		-0.3		$V_{REF} - 0.2$	V
$V_{OH}$	High-level output voltage	$I_{OH} = -8$ mA	$V_{TT} + 0.6$			V
$V_{OL}$	Low-level output voltage	$I_{OL} = 8$ mA			$V_{TT} - 0.6$	V

**Table 36. SSTL-3 Class II Specifications** *Note (10)*

Symbol	Parameter	Conditions	Minimum	Typical	Maximum	Units
$V_{CCIO}$	I/O supply voltage		3.0	3.3	3.6	V
$V_{TT}$	Termination voltage		$V_{REF} - 0.05$	$V_{REF}$	$V_{REF} + 0.05$	V
$V_{REF}$	Reference voltage		1.3	1.5	1.7	V
$V_{IH}$	High-level input voltage		$V_{REF} + 0.2$		$V_{CCIO} + 0.3$	V
$V_{IL}$	Low-level input voltage		-0.3		$V_{REF} - 0.2$	V
$V_{OH}$	High-level output voltage	$I_{OH} = -16 \text{ mA}$	$V_{TT} + 0.8$			V
$V_{OL}$	Low-level output voltage	$I_{OL} = 16 \text{ mA}$			$V_{TT} - 0.8$	V

**Table 37. 3.3-V AGP -2X Specifications**

Symbol	Parameter	Conditions	Minimum	Typical	Maximum	Units
$V_{CCIO}$	I/O supply voltage		3.15	3.3	3.45	V
$V_{REF}$	Reference voltage		$0.39 \times V_{CCIO}$		$0.41 \times V_{CCIO}$	V
$V_{IH}$	High-level input voltage (12)		$0.5 \times V_{CCIO}$		$V_{CCIO} + 0.5$	V
$V_{IL}$	Low-level input voltage (12)				$0.3 \times V_{CCIO}$	V
$V_{OH}$	High-level output voltage	$I_{OUT} = -20 \mu\text{A}$	$0.9 \times V_{CCIO}$		3.6	V
$V_{OL}$	Low-level output voltage	$I_{OUT} = 20 \mu\text{A}$			$0.1 \times V_{CCIO}$	V
$I_I$	Input pin leakage current	$0 < V_{IN} < V_{CCIO}$			$\pm 10$	$\mu\text{A}$

**Table 38. 3.3-V AGP -1X Specifications**

Symbol	Parameter	Conditions	Minimum	Typical	Maximum	Units
$V_{CCIO}$	I/O supply voltage		3.15	3.3	3.45	V
$V_{IH}$	High-level input voltage (12)		$0.5 \times V_{CCIO}$		$V_{CCIO} + 0.5$	V
$V_{IL}$	Low-level input voltage (12)				$0.3 \times V_{CCIO}$	V
$V_{OH}$	High-level output voltage	$I_{OUT} = -20 \mu\text{A}$	$0.9 \times V_{CCIO}$		3.6	V
$V_{OL}$	Low-level output voltage	$I_{OUT} = 20 \mu\text{A}$			$0.1 \times V_{CCIO}$	V
$I_I$	Input pin leakage current	$0 < V_{IN} < V_{CCIO}$			$\pm 10$	$\mu\text{A}$

**Table 39. 1.5-V HSTL Class I Specifications** *Note (10)*

Symbol	Parameter	Conditions	Minimum	Typical	Maximum	Units
$V_{CCIO}$	I/O supply voltage		1.4	1.5	1.6	V
$V_{REF}$	Input reference voltage		0.68	0.75	0.9	V
$V_{TT}$	Termination voltage		0.7	0.75	0.8	V
$V_{IH}$ (DC)	DC high-level input voltage		$V_{REF} + 0.1$			V
$V_{IL}$ (DC)	DC low-level input voltage		-0.3		$V_{REF} - 0.1$	V
$V_{IH}$ (AC)	AC high-level input voltage		$V_{REF} + 0.2$			V
$V_{IL}$ (AC)	AC low-level input voltage				$V_{REF} - 0.2$	V
$V_{OH}$	High-level output voltage	$I_{OH} = 8\text{ mA}$	$V_{CCIO} - 0.4$			V
$V_{OL}$	Low-level output voltage	$I_{OH} = -8\text{ mA}$			0.4	V

**Table 40. 1.5-V HSTL Class II Specifications** *Note (10)*

Symbol	Parameter	Conditions	Minimum	Typical	Maximum	Units
$V_{CCIO}$	I/O supply voltage		1.4	1.5	1.6	V
$V_{REF}$	Input reference voltage		0.68	0.75	0.9	V
$V_{TT}$	Termination voltage		0.7	0.75	0.8	V
$V_{IH}$ (DC)	DC high-level input voltage		$V_{REF} + 0.1$			V
$V_{IL}$ (DC)	DC low-level input voltage		-0.3		$V_{REF} - 0.1$	V
$V_{IH}$ (AC)	AC high-level input voltage		$V_{REF} + 0.2$			V
$V_{IL}$ (AC)	AC low-level input voltage				$V_{REF} - 0.2$	V
$V_{OH}$	High-level output voltage	$I_{OH} = 16\text{ mA}$	$V_{CCIO} - 0.4$			V
$V_{OL}$	Low-level output voltage	$I_{OH} = -16\text{ mA}$			0.4	V

**Table 41. CTT I/O Specifications**

Symbol	Parameter	Conditions	Minimum	Typical	Maximum	Units
$V_{CCIO}$	I/O supply voltage		3.0	3.3	3.6	V
$V_{TT}/V_{REF}$	Termination and input reference voltage		1.35	1.5	1.65	V
$V_{IH}$	High-level input voltage		$V_{REF} + 0.2$			V
$V_{IL}$	Low-level input voltage				$V_{REF} - 0.2$	V
$I_i$	Input pin leakage current	$0 < V_{IN} < V_{CCIO}$			$\pm 10$	$\mu\text{A}$
$V_{OH}$	High-level output voltage	$I_{OH} = -8\text{ mA}$	$V_{REF} + 0.4$			V
$V_{OL}$	Low-level output voltage	$I_{OL} = 8\text{ mA}$			$V_{REF} - 0.4$	V
$I_o$	Output leakage current (when output is high Z)	$GND \delta V_{OUT} \delta V_{CCIO}$			$\pm 10$	$\mu\text{A}$

**Table 42. Bus Hold Parameters**

Parameter	Conditions	VCCIO Level						Units
		1.8 V		2.5 V		3.3 V		
		Minimum	Maximum	Minimum	Maximum	Minimum	Maximum	
Low sustaining current	$V_{IN} > V_{IL}$ (maximum)	30		50		70		$\mu\text{A}$
High sustaining current	$V_{IN} < V_{IH}$ (minimum)	-30		-50		-70		$\mu\text{A}$
Low overdrive current	$0\text{ V} < V_{IN} < V_{CCIO}$		200		300		500	$\mu\text{A}$
High overdrive current	$0\text{ V} < V_{IN} < V_{CCIO}$		-200		-300		-500	$\mu\text{A}$

**Table 43. Mercury Device Capacitance** *Note (13)*

Symbol	Parameter	Minimum	Typical	Maximum	Unit
$C_{IO}$	I/O pin capacitance		13.5		$\text{pF}$
$C_{CLK}$	Input capacitance on CLK[4..1] pins		16.9		$\text{pF}$
$C_{RXHSDI}$	Input capacitance on HSDI receiver pins		8.0		$\text{pF}$
$C_{TXHSDI}$	Input capacitance on HSDI transmitter pins		18.0		$\text{pF}$
$C_{CLKHSDI}$	Input capacitance on HSDI clock pins		7.5		$\text{pF}$
$C_{FLEXLVDSRX}$	Input capacitance on flexible LVDS receiver pins		13.4		$\text{pF}$
$C_{FLEXLV DSTX}$	Input capacitance on flexible LVDS transmitter pins		13.4		$\text{pF}$

**Notes to Tables 20 – 43:**

- (1) See the *Operating Requirements for Altera Devices Data Sheet*.
- (2) Minimum DC input is  $-0.5$  V. During transitions, the inputs may undershoot to  $-0.5$  V or overshoot to  $4.1$  V for input currents less than  $100$  mA and periods shorter than  $20$  ns.
- (3) Maximum  $V_{CC}$  rise time is  $100$  ms, and  $V_{CC}$  must rise monotonically.
- (4)  $V_{CCIO}$  maximum and minimum conditions for LVPECL, LVDS, RapidIO, and  $3.3$ -V PCML are shown in parentheses.
- (5) All pins, including dedicated inputs, clock, I/O, and JTAG pins, may be driven before  $V_{CCINT}$  and  $V_{CCIO}$  are powered.
- (6) Typical values are for  $T_A = 25^\circ$  C,  $V_{CCINT} = 1.8$  V, and  $V_{CCIO} = 1.8$  V,  $2.5$  V, and  $3.3$  V.
- (7) These values are specified under the Mercury Device Recommended Operating Conditions shown in [Table 3 on page 3](#).
- (8) Input pins are grounded. In the test design, internal logic does not toggle. The test design does not use PLL or HSDI circuitry. All ESBs are in power-down mode.
- (9) Pin pull-up resistance values will lower if an external source drives the pin higher than  $V_{CCIO}$ .
- (10) Drive strength is programmable according to values in [Table 11 on page 53](#).
- (11) For more information on termination, see [AN 134: Using Programmable I/O Standards in Mercury Devices](#) or [AN 159: Using HSDI in Source-Synchronous Mode in Mercury Devices](#).
- (12)  $V_{REF}$  specifies the center point of the switching range.
- (13) Capacitance is sample-tested only. Capacitance is measured using time-domain reflections (TDR). Measurement accuracy is within  $\pm 5\%$ .

## Timing Model

The high-performance multi-level FastTrack Interconnect routing resources ensure predictable performance, accurate simulation, and accurate timing analysis. The predictable performance of Mercury devices offer an advantage over FPGAs, which use a segmented connection scheme and therefore have unpredictable performance.

[Figure 36](#) shows the timing model for bidirectional IOE pin timing. All registers are within the IOE.

**Figure 36. Synchronous Bidirectional Pin External Timing Model**

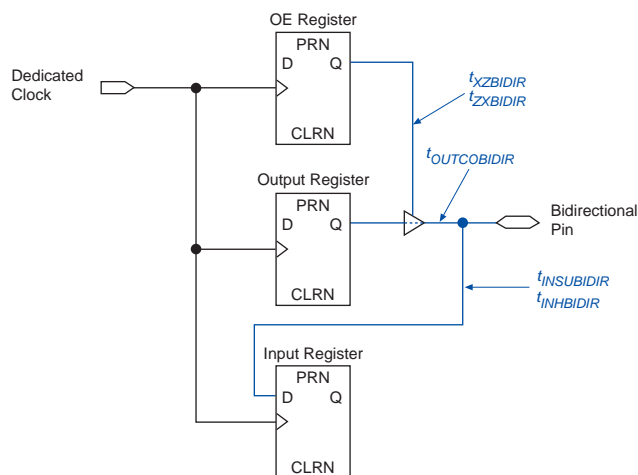

Tables 44 and 45 describe the Mercury device's external timing parameters.

Symbol	Parameter	Conditions
$t_{INSU}$	Setup time with global clock at IOE register	
$t_{INH}$	Hold time with global clock at IOE register	
$t_{OUTCO}$	Clock-to-output delay with global clock at IOE register	C1 = 35 pF
$t_{INSUPLL}$	Setup time with PLL clock at IOE input register	
$t_{INHPLL}$	Hold time with PLL clock at IOE input register	
$t_{OUTCOPLL}$	Clock-to-output delay with PLL clock at IOE output register	C1 = 35 pF

Symbol	Parameter	Conditions
$t_{INSUBIDIR}$	Setup time for bidirectional pins with global clock at IOE input register	
$t_{INHBIDIR}$	Hold time for bidirectional pins with global clock at IOE input register	
$t_{OUTCOBIDIR}$	Clock-to-output delay for bidirectional pins with global clock at IOE output register	C1 = 35 pF
$t_{XZBIDIR}$	Synchronous IOE output enable register to output buffer disable delay	C1 = 35 pF
$t_{ZXBIDIR}$	Synchronous IOE output enable register output buffer enable delay	C1 = 35 pF
$t_{INSUBIDIRPLL}$	Setup time for bidirectional pins with PLL clock at IOE input register	
$t_{INHBIDIRPLL}$	Hold time for bidirectional pins with PLL clock at IOE input register	
$t_{OUTCOBIDIRPLL}$	Clock-to-output delay for bidirectional pins with PLL clock at IOE output register	C1 = 35 pF
$t_{XZBIDIRPLL}$	Synchronous IOE output enable register to output buffer disable delay with PLL	C1 = 35 pF
$t_{ZXBIDIRPLL}$	Synchronous IOE output enable register output buffer enable delay with PLL	C1 = 35 pF

**Notes to Tables 44 and 45:**

- (1) These timing parameters are sample-tested only.
- (2) All timing parameters are either to and/or from pins, including global clock pins.

Tables 46 through 51 show external timing parameters for Mercury devices.

Symbol	-5 Speed Grade		-6 Speed Grade		-7 Speed Grade		Unit
	Min	Max	Min	Max	Min	Max	
$t_{INSU}$	0.67		0.70		0.73		ns
$t_{INH}$	0.00		0.00		0.00		ns
$t_{OUTCO}$	2.00	3.30	2.00	3.32	2.00	3.49	ns
$t_{INSUPLL}$	0.59		0.64		0.62		ns
$t_{INHPLL}$	0.00		0.00		0.00		ns
$t_{OUTCOPLL}$	0.50	2.08	0.50	2.08	0.50	2.15	ns

Symbol	-5 Speed Grade		-6 Speed Grade		-7 Speed Grade		Unit
	Min	Max	Min	Max	Min	Max	
$t_{INSUBIDIR}$	0.67		0.70		0.73		ns
$t_{INHBIDIR}$	0.00		0.00		0.00		ns
$t_{OUTCOBIDIR}$	2.00	3.30	2.00	3.32	2.00	3.49	ns
$t_{XZBIDIR}$		3.52		3.53		3.74	ns
$t_{ZXBIDIR}^{(2)}$		3.52		3.53		3.74	ns
$t_{ZXBIDIR}^{(3)}$		3.72		3.73		3.99	ns
$t_{INSUBIDIRPLL}$	0.59		0.64		0.62		ns
$t_{INHBIDIRPLL}$	0.00		0.00		0.00		ns
$t_{OUTCOBIDIRPLL}$	0.50	2.08	0.50	2.08	0.50	2.15	ns
$t_{XZBIDIRPLL}$		2.29		2.29		2.39	ns
$t_{ZXBIDIRPLL}^{(2)}$		2.29		2.29		2.39	ns
$t_{ZXBIDIRPLL}^{(3)}$		2.49		2.49		2.64	ns

Symbol	-7A Speed Grade		-8A Speed Grade		Unit
	Min	Max	Min	Max	
$t_{INSU}$	0.74		0.79		ns
$t_{INH}$	0.00		0.00		ns
$t_{OUTCO}$	2.00	3.50	2.00	4.10	ns
$t_{INSUPLL}$	0.62		0.75		ns
$t_{INHPLL}$	0.00		0.00		ns
$t_{OUTCOPLL}$	0.50	2.15	0.50	2.43	ns

Symbol	-7A Speed Grade		-8A Speed Grade		Unit
	Min	Max	Min	Max	
$t_{INSUBIDIR}$	0.74		0.79		ns
$t_{INHBIDIR}$	0.00		0.00		ns
$t_{OUTCOBIDIR}$	2.00	3.50	2.00	4.10	ns
$t_{XZBIDIR}$		3.75		4.30	ns
$t_{ZXBIDIR}^{(2)}$		3.75		4.30	ns
$t_{ZXBIDIR}^{(3)}$		4.00		4.58	ns
$t_{INSUBIDIRPLL}$	0.62		0.75		ns
$t_{INHBIDIRPLL}$	0.00		0.00		ns
$t_{OUTCOBIDIRPLL}$	0.50	2.15	0.50	2.43	ns
$t_{XZBIDIRPLL}$		2.39		2.67	ns
$t_{ZXBIDIRPLL}^{(2)}$		2.39		2.67	ns
$t_{ZXBIDIRPLL}^{(3)}$		2.64		2.95	ns

Symbol	-5 Speed Grade		-6 Speed Grade		-7 Speed Grade		Unit
	Min	Max	Min	Max	Min	Max	
$t_{INSU}$	0.60		0.57		0.71		ns
$t_{INH}$	0.00		0.00		0.00		ns
$t_{OUTCO}$	2.00	3.95	2.00	3.97	2.00	4.75	ns
$t_{INSUPLL}$	0.69		0.70		0.82		ns
$t_{INHPLL}$	0.00		0.00		0.00		ns
$t_{OUTCOPLL}$	0.50	2.23	0.50	2.23	0.50	2.69	ns

Symbol	-5 Speed Grade		-6 Speed Grade		-7 Speed Grade		Unit
	Min	Max	Min	Max	Min	Max	
$t_{\text{INSUBIDIR}}$	0.60		0.57		0.71		ns
$t_{\text{INHIBIDIR}}$	0.00		0.00		0.00		ns
$t_{\text{OUTCOBIDIR}}$	2.00	3.95	2.00	3.97	2.00	4.75	ns
$t_{\text{XZBIDIR}}$		3.90		3.93		4.70	ns
$t_{\text{ZXBIDIR}}^{(2)}$		3.90		3.93		4.70	ns
$t_{\text{ZXBIDIR}}^{(3)}$		4.10		4.13		4.94	ns
$t_{\text{INSUBIDIRPLL}}$	0.69		0.70		0.82		ns
$t_{\text{INHIBIDIRPLL}}$	0.00		0.00		0.00		ns
$t_{\text{OUTCOBIDIRPLL}}$	0.50	2.23	0.50	2.23	0.50	2.69	ns
$t_{\text{XZBIDIRPLL}}$		2.19		2.18		2.63	ns
$t_{\text{ZXBIDIRPLL}}^{(2)}$		2.19		2.18		2.63	ns
$t_{\text{ZXBIDIRPLL}}^{(3)}$		2.39		2.38		2.87	ns

**Notes to Tables 46 – 51:**

- (1) Timing will vary by I/O pin placement. Therefore, use the Quartus II software to determine exact I/O timing for each pin.
- (2) This parameter is measured with the **Increase  $t_{\text{ZX}}$  Delay to Output Pin** option set to **Off**.
- (3) This parameter is measured with the **Increase  $t_{\text{ZX}}$  Delay to Output Pin** option set to **On**.

## Power Consumption

Detailed power consumption information for Mercury devices will be released when available.

## Configuration & Operation

The Mercury architecture supports several configuration schemes. This section summarizes the device operating modes and available device configuration schemes.

### Operating Modes

The Mercury architecture uses SRAM configuration elements that require configuration data to be loaded each time the circuit powers up. The process of physically loading the SRAM data into the device is called configuration. During initialization, which occurs immediately after configuration, the device resets registers, enables I/O pins, and begins to operate as a logic device. The I/O pins are tri-stated during power-up and before and during configuration. Together, the configuration and initialization processes are called command mode; normal device operation is called user mode.

Before and during device configuration, all I/O pins are pulled to  $V_{CCIO}$  by a built-in weak pull-up resistor.

SRAM configuration elements allow Mercury devices to be reconfigured in-circuit by loading new configuration data into the device. Real-time reconfiguration is performed by forcing the device into command mode with a device pin, loading different configuration data, reinitializing the device, and resuming user-mode operation. In-field upgrades can be performed by distributing new configuration files.

### Configuration Schemes

The configuration data for a Mercury device can be loaded with one of five configuration schemes (see [Table 52](#)), chosen on the basis of the target application. A configuration device, intelligent controller, or the JTAG port can be used to control the configuration of a Mercury device. When a configuration device is used, the system can configure automatically at system power-up.

By connecting the configuration enable ( $nCE$ ) and configuration enable output ( $nCEO$ ) pins on each device, multiple Mercury devices can be configured in any of five configuration schemes.

Configuration Scheme	Data Source
Configuration device	Configuration device
Passive serial (PS)	MasterBlaster™ or ByteBlasterMV™ download cable or serial data source
Passive parallel asynchronous (PPA)	Parallel data source
Passive parallel synchronous (PPS)	Parallel data source
JTAG	MasterBlaster or ByteBlasterMV download cable or a microprocessor with a Jam STAPL or JBC file



For more information on configuration, see [Application Note 116 \(Configuring APEX 20K, FLEX 10K & FLEX 6000 Devices\)](#).

### Device Pin-Outs

See the Altera web site (<http://www.altera.com>) or the *Altera Digital Library* for pin-out information.

## Revision History

The information contained in the *Mercury Programmable Logic Device Family Data Sheet* version 2.2 supersedes information published in previous versions.

### Version 2.2

The following changes were made to the *Mercury Programmable Logic Device Family Data Sheet* version 2.2:

- Updated the condition values (symbols  $I_I$  and  $I_{OZ}$ ) in [Table 22](#).

### Version 2.1

The following changes were made to the *Mercury Programmable Logic Device Family Data Sheet* version 2.1:

- Updated [Table 8](#).
- Updated EP1M350 regular I/O banks in [Table 13](#).
- Updated [Note \(6\)](#) in [Table 14](#).

### Version 2.0

The following changes were made to the *Mercury Programmable Logic Device Family Data Sheet* version 2.0:

- Changed all references to PCML to 3.3-V PCML.
- Updated [Table 4](#).
- Updated “[High-Speed Differential Interface](#)” on [page 8](#).
- Added [Tables 6 through 8](#).
- Added [Figures 34 and 35](#).
- Updated I/O specifications in [Tables 28 and 29](#).
- Updated Mercury device capacitance in [Table 43](#).
- Updated EP1M120 device timing in [Tables 46 through 49](#).
- Added EP1M350 device timing in [Tables 50 and 51](#).



101 Innovation Drive  
San Jose, CA 95134  
(408) 544-7000  
<http://www.altera.com>  
**Applications Hotline:**  
(800) 800-EPLD  
**Customer Marketing:**  
(408) 544-7104  
**Literature Services:**  
[lit\\_req@altera.com](mailto:lit_req@altera.com)

Copyright © 2003 Altera Corporation. All rights reserved. Altera, The Programmable Solutions Company, the stylized Altera logo, specific device designations, and all other words and logos that are identified as trademarks and/or service marks are, unless noted otherwise, the trademarks and service marks of Altera Corporation in the U.S. and other countries. All other product or service names are the property of their respective holders. Altera products are protected under numerous U.S. and foreign patents and pending applications, mask work rights, and copyrights. Altera warrants performance of its semiconductor products to current specifications in accordance with Altera's standard warranty, but reserves the right to make changes to any products and services at any time without notice. Altera assumes no responsibility or liability arising out of the application or use of any information, product, or service described herein except as expressly agreed to in writing by Altera Corporation. Altera customers are advised to obtain the latest version of device specifications before relying on any published information and before placing orders for products or services.



I.S. EN ISO 9001

## Looking for pricing, stock, or lifecycle information?

Click below to explore more details on WIN SOURCE:

 [View EP1M120F484I6 on WIN SOURCE](#)

 [Altera Information](#)

## Optimize Your Supply Chain with WIN SOURCE Solutions

-  Global Sourcing Solution
-  Obsolete Management
-  Cost Control Management
-  Shortage Management
-  Alternative Solution
-  Excess Inventory Management