



**THE DATASHEET OF
EN5310DC**





EN5310

1A Voltage Mode Synchronous Buck PWM
DC-DC Converter with Integrated Inductor
RoHS Compliant

Description

The EN5310 is a Power System on a Chip DC-DC converter. It is specifically designed to meet the precise voltage and fast transient requirements of present and future high-performance, low-power processor, DSP, FPGA, memory boards and system level applications in a distributed power architecture. Advanced circuit techniques, ultra high switching frequency, and very advanced, high-density, integrated circuit and proprietary inductor technology deliver high-quality, ultra compact, non-isolated DC-DC conversion. Operating this converter requires only three external components that include small value input and output ceramic capacitors and a soft-start capacitor.

The EN5310 significantly helps in system design and productivity by offering greatly simplified board design, layout and manufacturing requirements. In addition, a reduction in the number of vendors required for the complete power solution helps to enable an overall system cost savings.

Typical Application Circuit

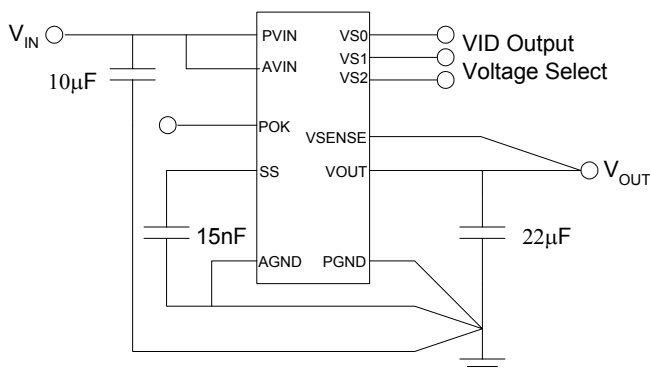

Features

- 1000mA output current capacity
- External inductor is NOT required
- RoHS compliant, MSL3 rated to 260°C
- 5MHz operating frequency
- More than 90% efficient
- V_{OUT} accuracy of 2% over line, load and temperature
- 1/2 the board area of discrete component solutions
- Very fast transient response
- All high speed switching signals contained inside the part
- Wide input voltage range of 2.375V to 5.5V
- Digital voltage selector with options for common output voltages from 0.8V to 3.3V
- External divider option for programming output voltages from 0.9V to 4.0V
- Output enable pin and Power OK signal
- Programmable soft-start time
- Programmable over-current protection
- Thermal shutdown, short circuit, over-voltage and under-voltage protection

Applications

- VOIP phones, video telephones
- Broadband, networking, LAN/WAN, optical telecommunications equipment
- Point of load regulation for low-power processors, network processors, DSPs, FPGAs, and ASICs
- Low voltage, distributed power architectures with 2.5V, 3.3V or 5V rails

Ordering Information

Part Number	Temp Rating (°C)	Package
EN5310DC-T	0 to 70	36-pin DFN T&R
EN5310DI-T	-40 to +85	36-pin DFN T&R
EN5310DC-E	DFN Evaluation Board	

Pin Configuration

This diagram is a top-view of the component and represents the on-board layout requirements for the landing pads and thermal connection points. Specific dimensions for the pads are presented on page 10. Pin 1 of the device is signified by the white dot marked on the top of the device.

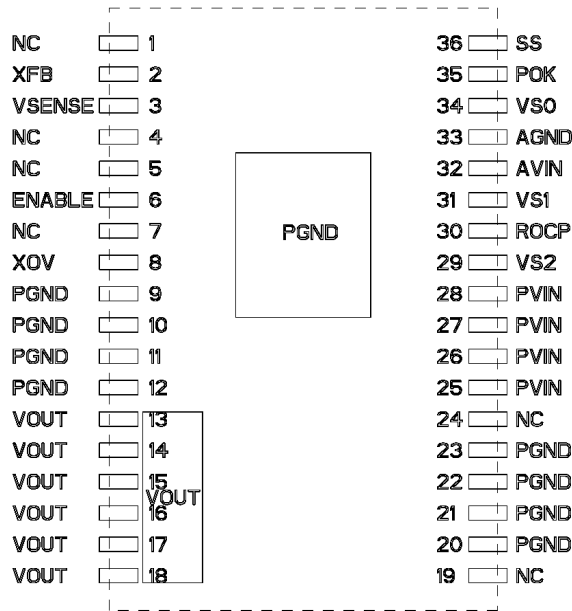

Block Diagram

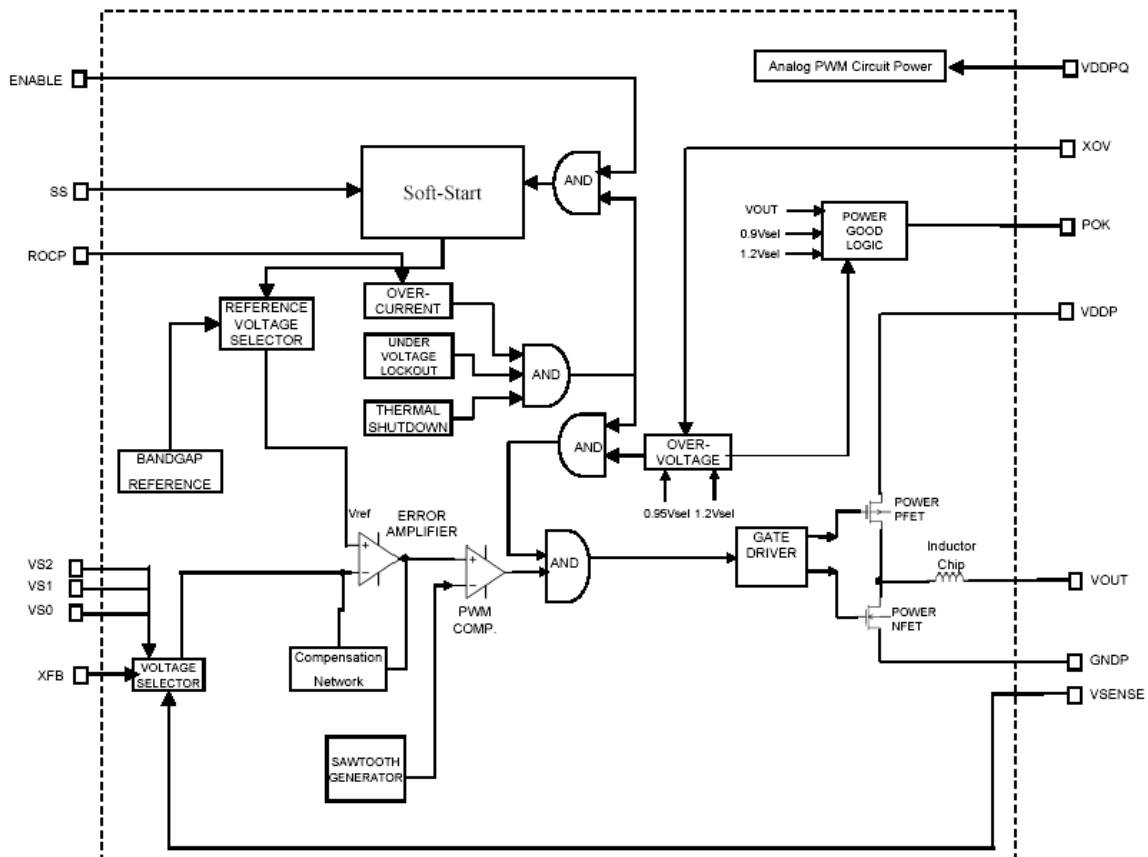

Typical Efficiency

$V_{IN} = 3.3V$ and $V_{OUT} = 2.5V$

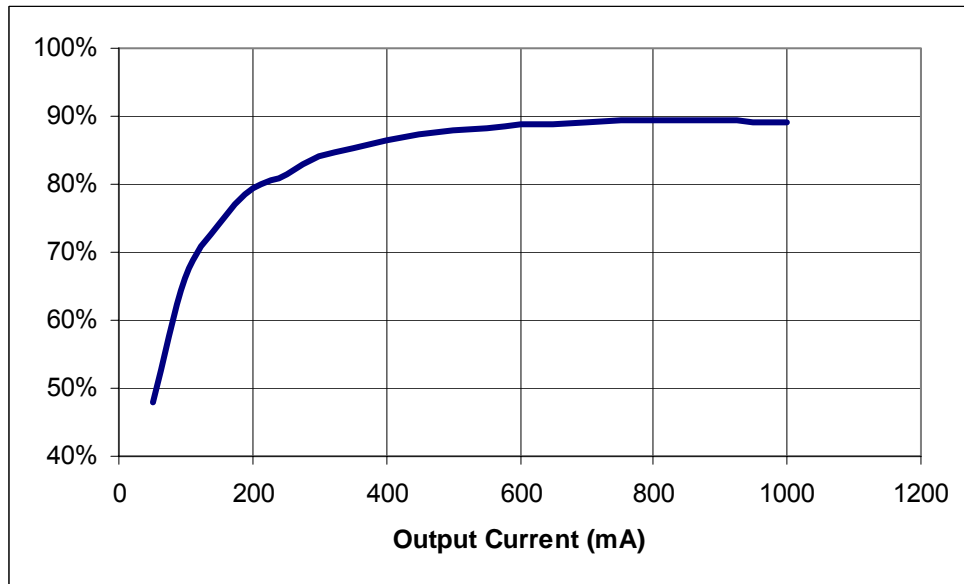

Absolute Maximum Ratings

CAUTION: Stresses in excess of the absolute maximum ratings can cause permanent damage to the device. Exposure to absolute maximum ratings for extended periods can adversely affect device reliability.

PARAMETER	SYMBOL	MIN	MAX	UNITS
Input Supply Voltage	V_{IN}	-0.5	6.5	V
Input Voltage – Enable		-0.5	V_{IN}	V
Input Voltage – VS0, VS1 & VS2 (Note 1)		-0.5	2.8	V
Storage Temperature Range	T_{STG}	-65	150	°C
Operating Junction Temperature	T_J		150	°C
MSL per JEDEC J-STD-020A Level 3			260	°C
ESD Rating (based on Human Body Model)			2000	V

NOTES:

- VS0, VS1 and VS2 pins have an internal pull-up resistor, only ground potentials should be placed on them as required.

Thermal Characteristics

PARAMETER	SYMBOL	TYPICAL	UNITS
Thermal Resistance: Junction to Ambient (0 LFM) (Note 2)	θ_{JA}	36	°C/W
Thermal Resistance: Junction to Case (0 LFM)	θ_{JC}	6	°C/W

NOTES:

- Based on a four-layer board and proper thermal design.



Electrical Characteristics

NOTE: V_{IN} =3.3V and over operating temperature range unless otherwise noted. Typical values are at $T_A = 25^\circ\text{C}$.

PARAMETER	SYMBOL	TEST CONDITIONS	MIN	TYP	MAX	UNITS
Operating Input Voltage	V_{IN}		2.375		5.5	V
Quiescent Supply Current	I_Q	No switching, $A_{VIN} = 3.3\text{V}$, $P_{VIN} = 3.3\text{V}$, $ENABLE=0\text{V}$		15		mA
No-Load Operating Current	I_{NL}	Includes PWM, gate drive and inductor ripple current.		35		mA
Switching Frequency	F_{OSC}			5		MHz
Thermal Overload Trip Point	T_J			160		$^\circ\text{C}$
V_{OUT}						
Range	V_{OUT}	Using external voltage divider	0.9			V
Accuracy	V_{OUT}	Over line, load and temperature			2.0	%
Line Regulation	$\square V_{OUT}$	$V_{IN} = 2.5$ to 5.0 volts		3		mV
Load Regulation	$\square V_{OUT}$	$I_{LOAD} = 0$ to 1A		3		mV
Temperature Regulation	$\square V_{OUT}$	$T_A = 0$ to 70°C		+0.25 -0.45		%
	$\square V_{OUT}$	$T_A = -40$ to 85°C		+ 0.65 -0.55		%
Transient Response ($I_{OUT} = 0\%$ to 100% or 100% to 0% of Rated Load)						
Peak Deviation	V_{OUT}	$V_{IN} = 5\text{V}$, $1.2\text{V} < V_{OUT} < 3.3\text{V}$		2	5	%
Output Voltage Ripple						
Peak-to-peak	V_{OUT-PP}	$V_{IN} = 5.0\text{V}$, $V_{OUT} = 1.2\text{V}$, $I_{OUT} = 1\text{A}$, $C_{OUT} = 20\mu\text{F}$, $2 \times 10\mu\text{F} \text{ X5R}$ or X7R ceramic capacitors		12		mV
Maximum Continuous Output Current (Note 3)						
Output Current	I_{OUT}				1000	mA
Enable Operation						
Disable Threshold	$V_{DISABLE}$	Max voltage to ensure the converter is disabled			0.8	V
Enable Threshold	V_{ENABLE}	Min voltage to ensure the converter is enabled	1.8			V
Power OK Operation						
POK low voltage	V_{POK}	$I_{POK} = 1\text{mA}$			0.4	V
Max POK Voltage	V_{POK}	Supply voltage applied to POK			5.5	V

NOTES:

- Maximum output current may need to be de-rated, based on operating condition, to meet T_J requirements.



Pin Descriptions

PIN	NAME	FUNCTION
1	NC	NO CONNECT – Do not electrically connect this pin to PCB. See Note 4.
2	XFB	External feedback voltage input. Option for programming the output voltage with a resistor divider on V_{OUT} .
3	VSENSE	Remote voltage sense input. Connect this pin to the load voltage at the point to be regulated.
4	NC	NO CONNECT – Do not electrically connect this pin to PCB. See Note 4.
5	NC	NO CONNECT – Do not electrically connect this pin to PCB. See Note 4.
6	ENABLE	Enable input. An input high enables operation. An input low disables operation.
7	NC	NO CONNECT – Do not electrically connect this pin to PCB. See Note 4.
8	XOV	Over-Voltage set-point input. When using an external voltage divider and the XFB pin. When VS0, VS1 and VS2 are left OPEN or pulled high, an additional voltage divider separate from the XFB pin is required to set the OVP set-point. In this mode, the OVP function is disabled if this voltage divider is not present.
9	PGND	Power ground for the power stage circuits.
10		
11		
12		
13	VOUT	Voltage and power output.
14		
15		
16		
17		
18		
19	NC	NO CONNECT – Do not electrically connect this pin to PCB. See Note 4.
20	PGND	Power ground for the power stage circuits.
21		
22		
23		
24	NC	NO CONNECT – Do not electrically connect this pin to PCB. See Note 4.
25	PVIN	Power voltage input for the power stage circuits.
26		
27		
28		
29	VS2	Voltage select line 2 input. See Table 1.
30	ROCP	Over-Current trip point adjust input. Used for adjusting the OCP trip point.
31	VS1	Voltage select line 1 input. See Table 1.
32	AVIN	Analog voltage input for the controller circuits.
33	AGND	Analog ground for the controller circuits.
34	VS0	Voltage select line 0 input. See Table 1.
35	POK	Power OK is an open drain transistor for power system state indication.
36	SS	Soft-Start node. A capacitor is connected between this pin and AGND.

NOTES:

- This pin is used for engineering test purposes and reserved for future use. Solder, but do not electrically connect this pin to the PCB.



Theory of Operation

Synchronous Buck Converter

The EN5310 is a synchronous, pin programmable power supply with integrated power MOSFET switches and inductor. The nominal input voltage range is 2.5-5.0V. The output can be set to common voltages by connecting appropriate combinations of 3 voltage selection pins to ground. If different voltage levels are required, provision is also made to allow external programming. The feedback control loop is voltage-mode and the part uses a low-noise PWM topology. Up to 1A of output current can be drawn from this converter. The 5MHz operating frequency enables the use of small-size output capacitors.

The power supply also has protection features such as:

- Programmable over-current protection (to protect the IC from excessive load current)
- Thermal shutdown (to protect the converter from getting too hot)
- Over-voltage protection that stops the PWM switching and turns on the lower N-MOSFET at 120% of the programmed output voltage in order to protect the load from an OV condition.
- Under-voltage lockout circuit to disable the converter output when the input voltage is less than approximately 2.2V

Additional features include:

- Soft-start circuit, limiting the in-rush current when the converter is powered up.
- Power good circuit indicating whether the output voltage is within 90%-120% of the programmed voltage.

Output Voltage Programming

The EN5310 output voltage is programmed using one of two methods. Common output voltages are achieved by tying one or more of the three Voltage Select pins (VS0, VS1 & VS2) to ground

(see Table 1). If all three are left floating, the output voltage and over voltage thresholds are determined by the voltages presented at the XFB and XOV pins respectively. These voltages should be set by way of resistor dividers between V_{OUT} to GND with the midpoint going to XFB and XOV.

Use an appropriate resistor ratio such that the desired output voltage across the resistor pair causes the XFB pin to be 0.8V at the nominal set-point. It is recommended that the resistor values used should be in the 20K-40K range. Contact Enpirion Applications Support for more specific information. If Over-Voltage protection is required, the output of a second divider to XOV should be set such that 0.96V is present at the desired trip point. By design, if both resistor dividers are the same, the OV trip-point will be 20% above the nominal output voltage.

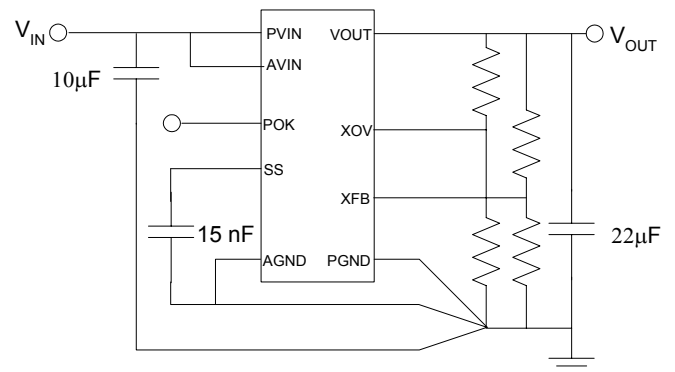

Table 1: Output Voltage Select Table

VS2*	VS1*	VS0*	Output Voltage
0	0	0	3.3V
0	0	1	2.5V
0	1	0	1.8V
0	1	1	1.5V
1	0	0	1.25V
1	0	1	1.2V
1	1	0	0.8V**
1	1	1	User Selectable

** 0.8V ref only, not guaranteed performance

*NOTE: The VS0, VS1 and VS2 pins are defaulted to a '1' with an internal pull-up resistor. Only connect these pins to AGND if a '0' is required. If a '1' is required, then leave the pin floating.



Capacitor Selection

The EN5310 needs about 10-20 μ F of input capacitance. Low-cost, low-ESR ceramic capacitors must be used as input capacitors for this converter and it is required that they be rated X5R or X7R. In some applications, lower value capacitors are needed in parallel with the larger, lossy capacitors in order to provide high frequency decoupling.

The EN5310 has been optimized for use with about 20 μ F of ceramic output capacitance. It is required that these be low-cost, low-ESR, ceramic capacitors rated X5R or X7R. (See the Enpirion application note on ripple comparison for optimum selection of number and value of these capacitors based on ripple requirements.) In order to eliminate high-frequency switching spikes on the output ripple, usually a low-value, low-ESR ceramic capacitor is used in parallel with the larger capacitors right at the load.

Enable Operation

The ENABLE pin provides a means to shut down the power FET switching or enable normal operation. A logic low will disable the converter and cause it to shut down. A logic high will enable the converter into normal operation.

Soft-Start Operation

The SS pin in conjunction with a small capacitor between this pin and AGND provides the soft start function to limit the in-rush current during start-up. During start-up of the converter the reference voltage to the error amplifier is gradually increased to its final level by an internal current source of typically 10 μ A. The whole soft-start procedure is designed to take 1ms - 3ms with a 15-30nF soft start capacitor, but can be programmed by capacitor selection using the following equation:

$$\text{Rise Time: } T_R = C_{SS} * 80k$$

POK Operation

The POK signal is an open drain signal from the converter indicating the output voltage is within the specified range. The POK signal will be a logic high when the output voltage is within 90% - 120% of the programmed output voltage. If the output voltage goes outside of this range, the POK signal will be a logic low until the output voltage has returned to within this range. In the event of an over-voltage condition the POK signal will go low and will remain in this condition until the output voltage has dropped to 95% of the programmed output voltage before returning to the high state (see also Over Voltage Protection)

Over-Current Protection

The cycle-by-cycle current limit function is achieved by sensing the current flowing through the sense P-MOSFET and a signal generated by a differential amplifier with a preset over-current threshold. During a particular cycle, if the over-current threshold is exceeded, the power P-MOSFET is turned off and the power N-MOSFET is turned on to protect the P-MOSFET. If the over-current condition is removed, the over-current protection circuit will enable the PWM operation. If the over-current condition persists, the converter will eventually go through a full soft-start cycle. This circuit is designed to provide high noise immunity.

It is possible to adjust the over-current set point by connecting a resistor between ROCP and GND

(increase the trip point) or PVIN (decrease the trip point). The voltage at the ROCP pin is designed to be 0.8V. (see application note for details)

Over-Voltage Protection

When the output voltage exceeds 120% of the programmed output voltage, the PWM operation stops, the lower N-MOSFET is turned on and the POK signal goes low. When the output voltage drops below 95% of the programmed output voltage, normal PWM operation resumes and



POK returns to its high state.

Thermal Overload Protection

Thermal shutdown will disable operation once the Junction temperature exceeds approximately 160°C. Once the junction temperature drops by approx 25°C, the converter will re-start with a normal soft-start.

Low Input Voltage Operation

Circuitry is provided to ensure that when the input voltage is below the specified voltage range, the operation of the converter is controlled and predictable. Circuits for hysteresis, input de-glitch and output leading edge blanking are included to ensure high noise immunity and prevent false tripping.

Compensation

The EN5310 is internally compensated through the use of a type 3 compensation network and is optimized for use with about 20µF of output capacitance and will provide excellent loop bandwidth and transient performance for most applications. (See the section on Capacitor Selection for details on recommended capacitor types.) In some cases modifications to the compensation may be required. For more information, contact Enpirion Applications Engineering support.

Layout Considerations

The EN5310 Layout Guidelines application note provides more details on specific layout recommendations for this part. The following are general layout guidelines to consider.

The CMOS chip inside the EN5310 has two grounds: AGND for the controller, and PGND for

the power stage. These two grounds need to be connected outside the package at one point through a low-impedance trace. The connection should be made such that the impedance between the connection point and the AGND pad on the package is minimized. Since the internal voltage sensing circuit is based on AGND, the connection of the two grounds should also be made such that the best voltage regulation can be achieved. The soft-start capacitor, the voltage programming resistors, and any other external control component should be tied to AGND.

The placement of the input decoupling capacitors between PVIN and PGND is very critical. These components should be placed such that they have the lowest inductance traces to PVIN and PGND.

There are two thermal pads underneath the device. The centrally located pad is PGND, and, depending on the number of layers of the PC board, it needs to be connected to a thermal plane in order to conduct heat away from the device. Note that if any of the thermal planes is also connected to AGND, the impedance between this point and the GND connection of the load needs to be minimized in order to get the best possible load regulation. The pad opposite the V_{OUT} pins is connected to V_{OUT}. This V_{OUT} pad should be connected to a top layer copper area as large as possible to conduct more heat away from the package. This will also help minimize the trace length to the output filter caps.

Pin 19 is a connected to a noisy internal node and is brought out for test purposes only. Keep all sensitive signal traces as far as possible from this pin. Ideally, on the top layer there should be no traces or vias underneath the package between this pin and the V_{OUT} thermal pad.

Packaging Information

Mechanical Drawing and Nominal Dimensions

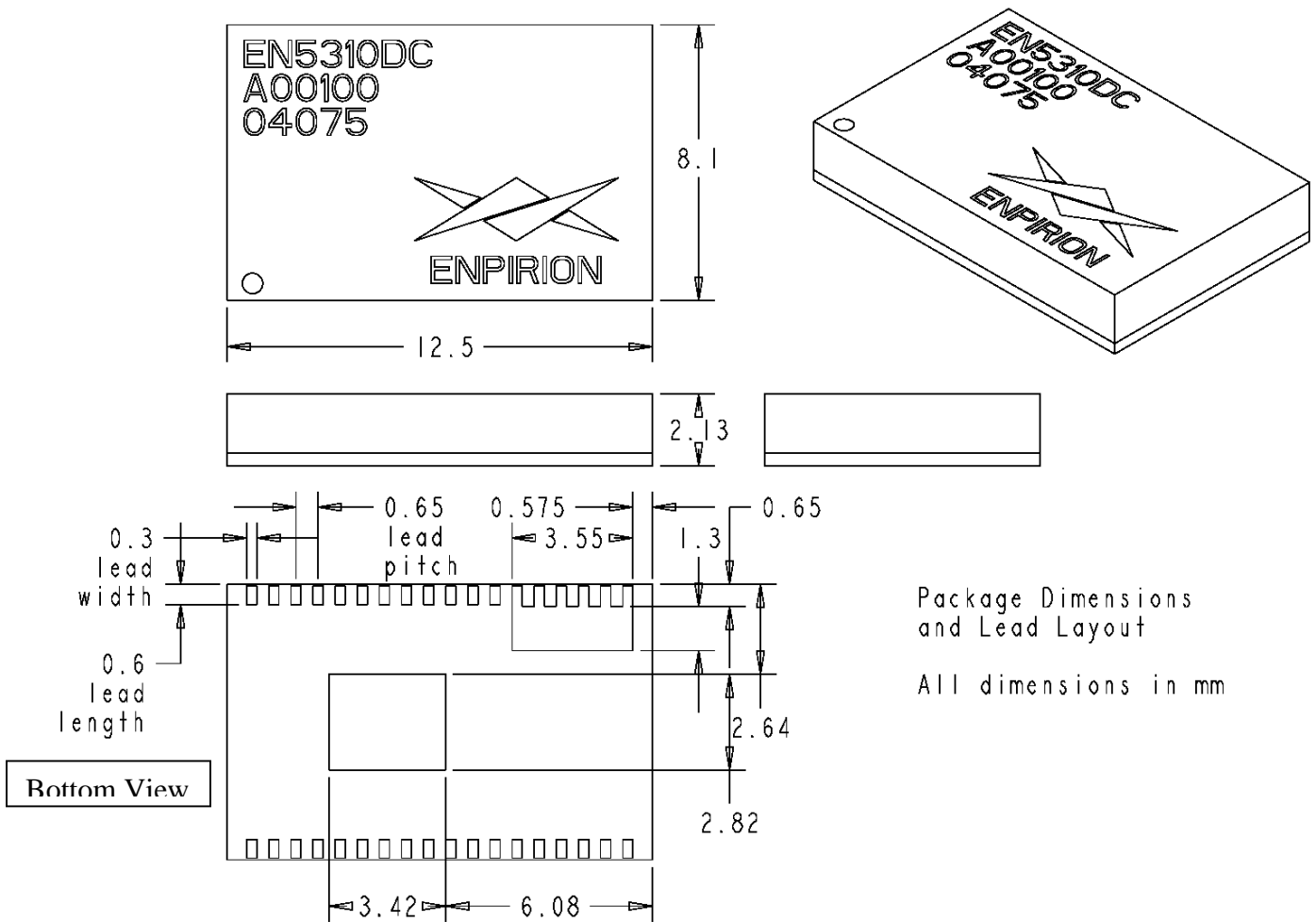

Looking for pricing, stock, or lifecycle information?

Click below to explore more details on WIN SOURCE:

 [View EN5310DC on WIN SOURCE](#)

 [Intel Information](#)

Optimize Your Supply Chain with WIN SOURCE Solutions

-  Global Sourcing Solution
-  Obsolete Management
-  Cost Control Management
-  Shortage Management
-  Alternative Solution
-  Excess Inventory Management