



# THE DATASHEET OF EMIF02-SPK02F2



### Features

- Packaged in lead-free Flip Chip
- Very low resistance: 0.35  $\Omega$
- High attenuation: -45 dB at 900 MHz
- Very low PCB space consumption: 0.89 mm x 1.26 mm
- Very thin package: 0.65 mm
- High efficiency in ESD suppression IEC6 1000-4-2 level 4
- High reliability offered by monolithic integration
- High reduction of parasitic elements through integration and wafer level packaging

### Complies with the following standards

- IEC 61000-4-2 level 4:
  - $\pm 15$  kV (air discharge)
  - $\pm 8$  kV (contact discharge)

### Application

- Mobile phones

### Description

The EMIF02-SPK02F2 chip is a highly integrated device designed to suppress EMI/RFI noise for interface line filtering.

The EMIF02-SPK02F2 flip-chip packaging means the package size is equal to the die size. That's why the EMIF02-SPK02F2 is a very small device.

Additionally, this filter includes ESD protection circuitry, which prevents damage to the protected device when subjected to ESD surges up to 30 kV.

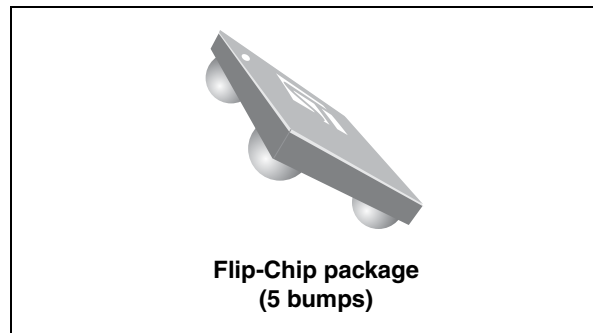

**Figure 1. Pin configuration (bump side)**

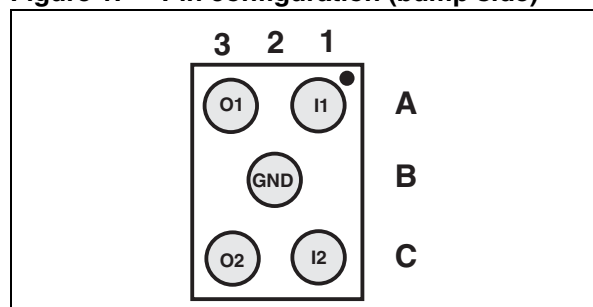

**Figure 2. Functional schematic**

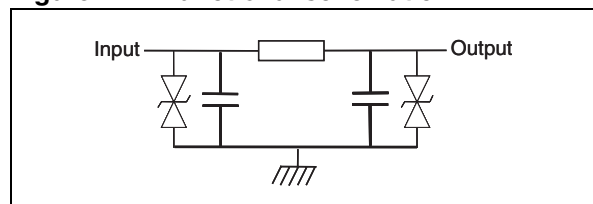

TM: IPAD is a trademark of STMicroelectronics

# 1 Characteristics

**Table 1. Absolute maximum ratings ( $T_{amb} = 25\text{ }^{\circ}\text{C}$ )**

Symbol	Parameter	Value	Unit
$V_{PP}$	ESD discharge IEC 61000-4-2		
	Air discharge	30	kV
	Contact discharge	30	
$I_{SPK}$	Maximum rms current per channel	350	mA
$T_j$	Junction temperature range	-30 to 125	$^{\circ}\text{C}$
$T_{stg}$	Storage temperature range	-55 to + 150	$^{\circ}\text{C}$

**Figure 3. Electrical characteristics - definitions**

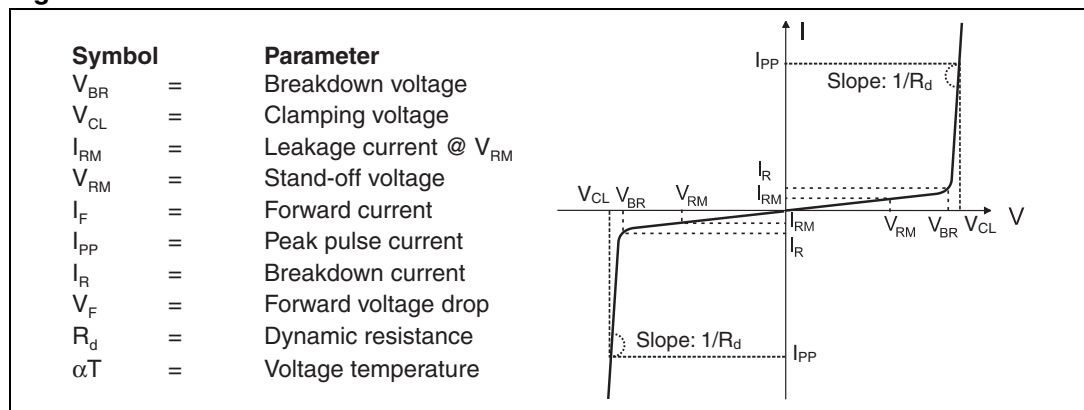

**Table 2. Electrical characteristics - values ( $T_{amb} = 25\text{ }^{\circ}\text{C}$ )**

Symbol	Test conditions	Min	Typ	Max	Unit
$V_{BR}$	$I_R = 1\text{ mA}$	6			V
$I_{RM}$	$V_{RM} = 3\text{ V}$			400	nA
$R_{I/O}$			0.35	0.8	$\Omega$
$C_{LINE}$	$V_R = 0\text{ V DC}, 1\text{ MHz}$	185	250	315	pF
$F_c$	Cut-off frequency: $Z_{SOURCE} = Z_{LOAD} = 50\ \Omega$		20		MHz

Figure 4. Attenuation measurements versus frequency

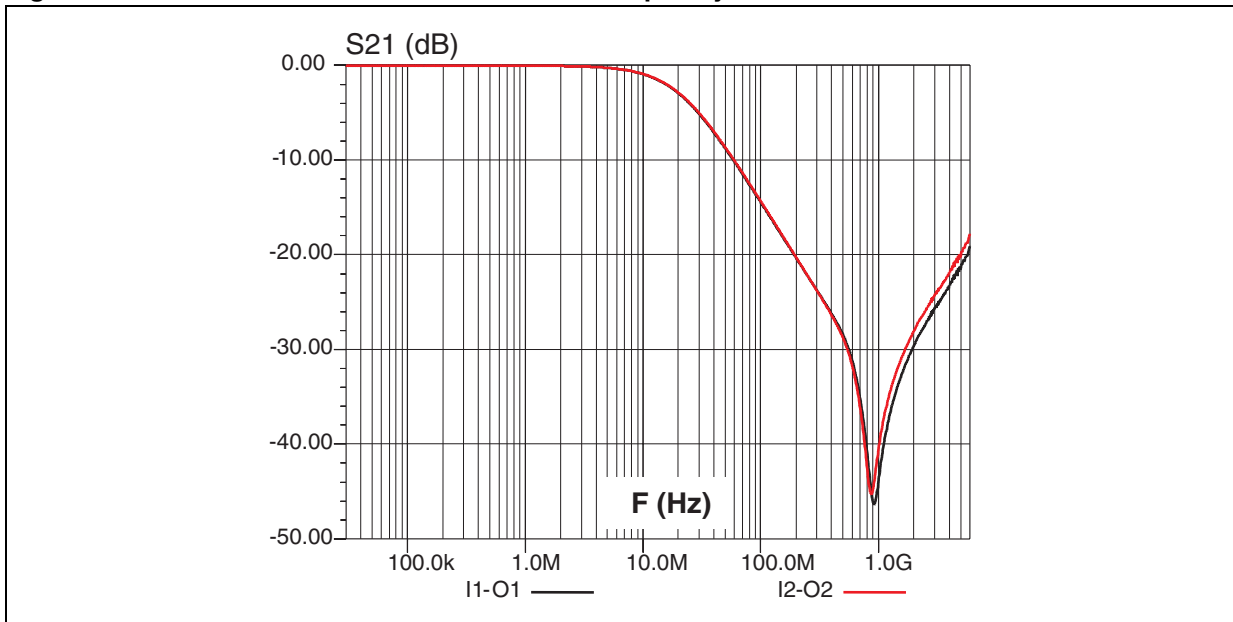

Figure 5. Crosstalk measurements versus frequency

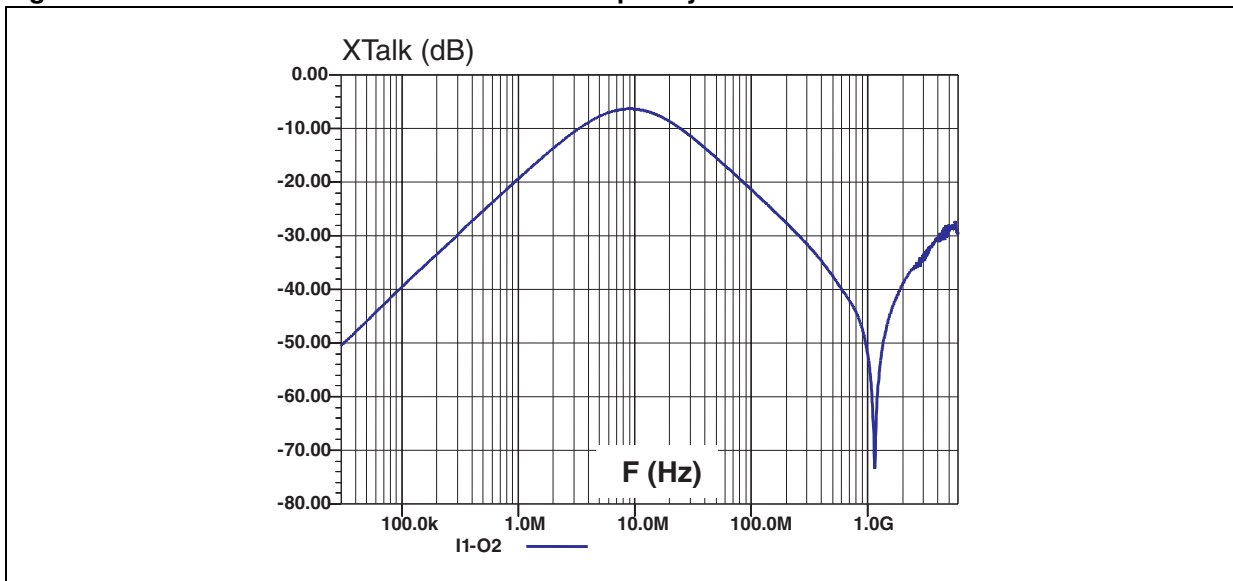

Figure 6. ESD test conditions

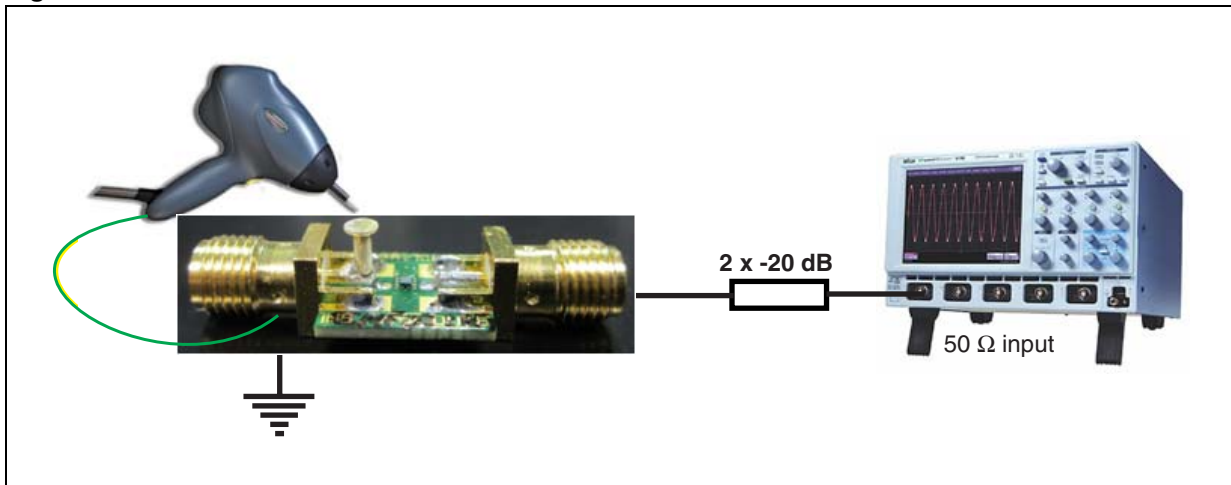
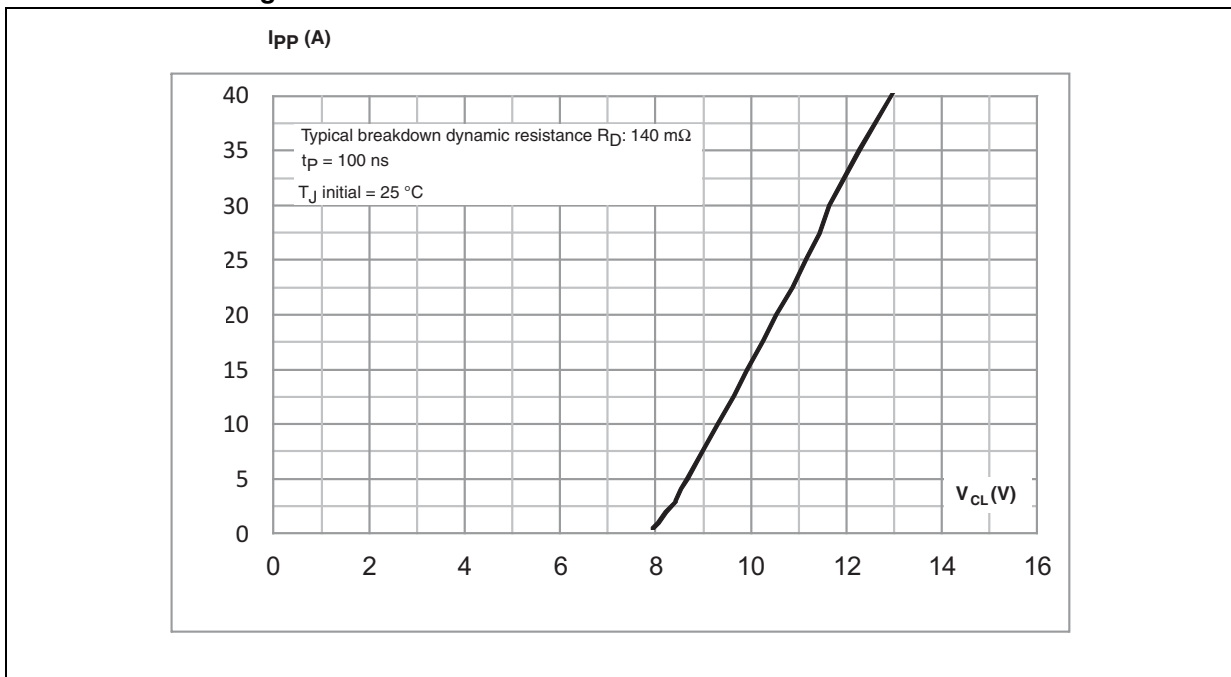

Figure 7. Clamping voltage  $V_{CL}$  versus peak pulse current  $I_{PP}$  for short pulse duration such as ESD surges



Note: For further information on the dynamic characteristic see the STMicroelectronics' application note AN4022, "TVS short pulse  $R_D$  measurement and correlation with TVS clamping voltage during ESD".

Figure 8. Output filter ESD response to IEC 61000-4-2 (+8 kV contact discharge) I1 to O1

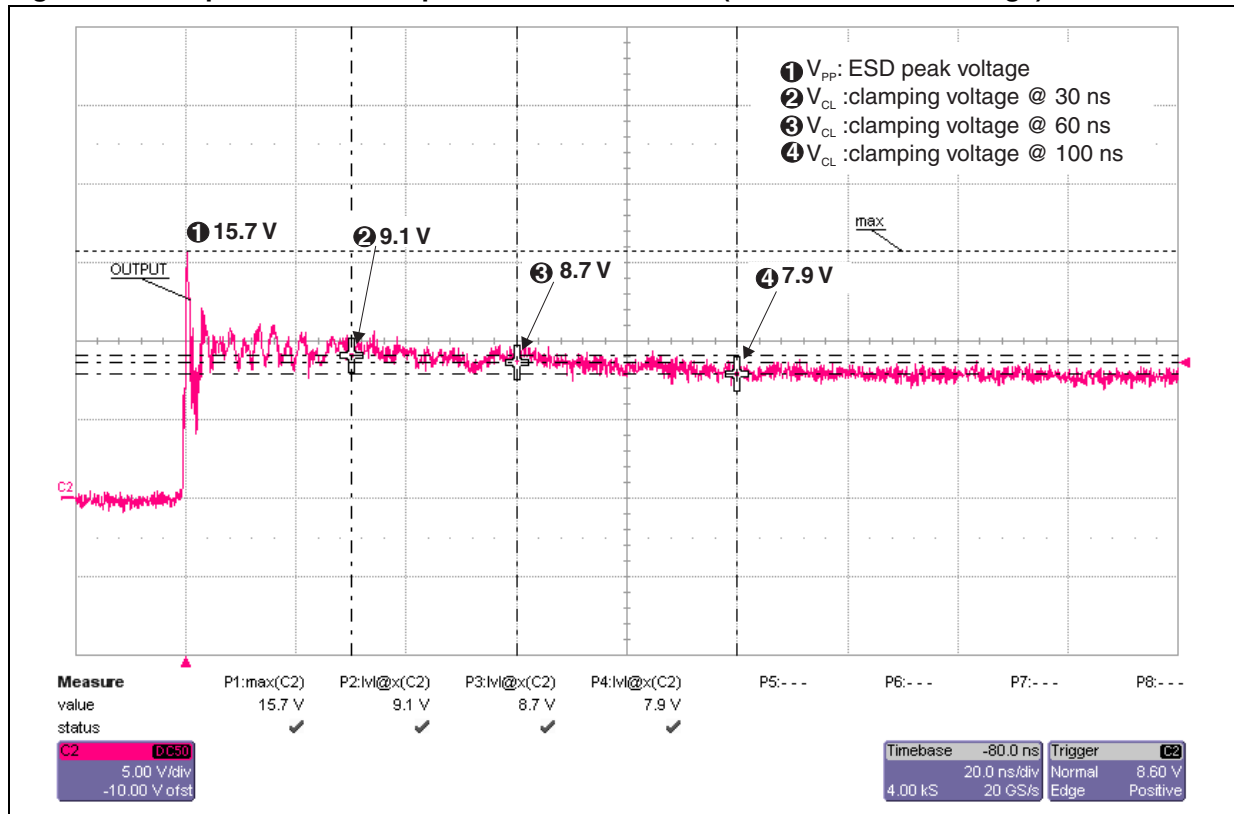

Figure 9. Output filter ESD response to IEC 61000-4-2 (-8 kV contact discharge) I1 to O1

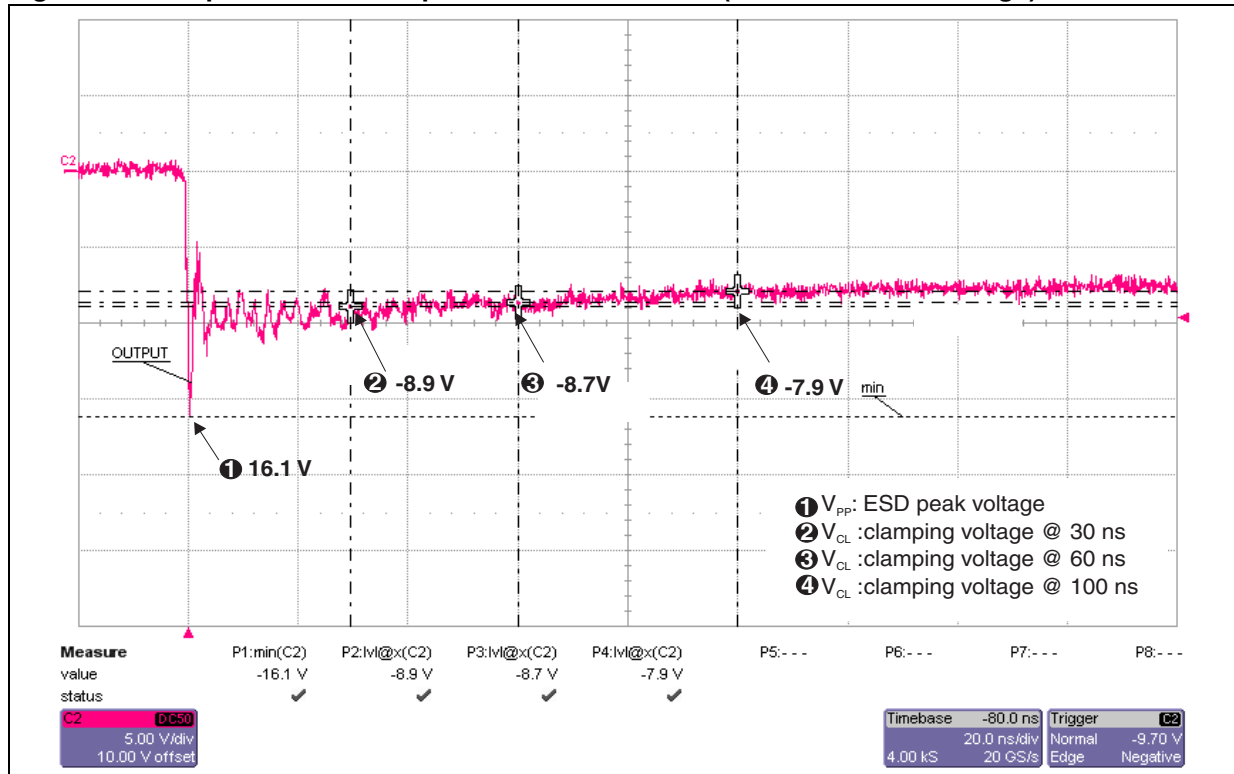

Figure 10. Output filter ESD response to IEC 61000-4-2 (+15 kV contact discharge) I1 to O1

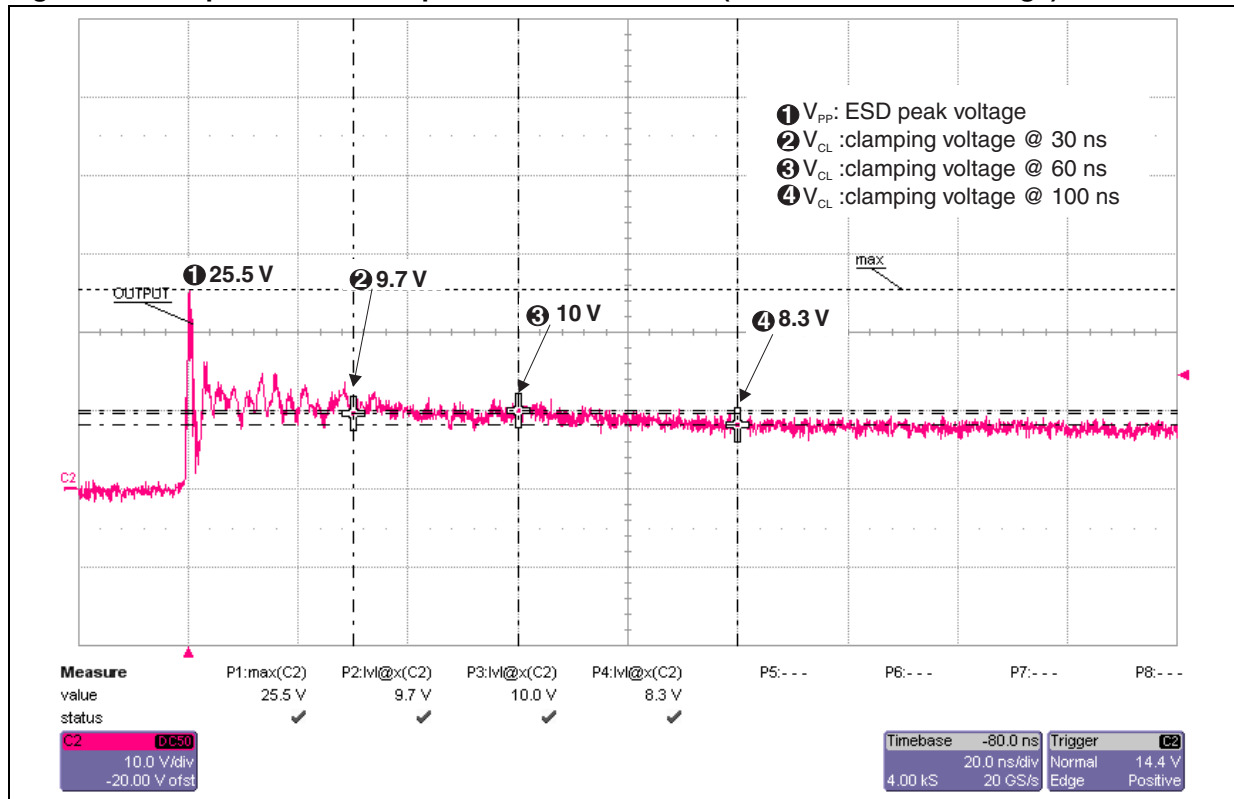

Figure 11. Output filter ESD response to IEC 61000-4-2 (-15 kV contact discharge) I1 to O1

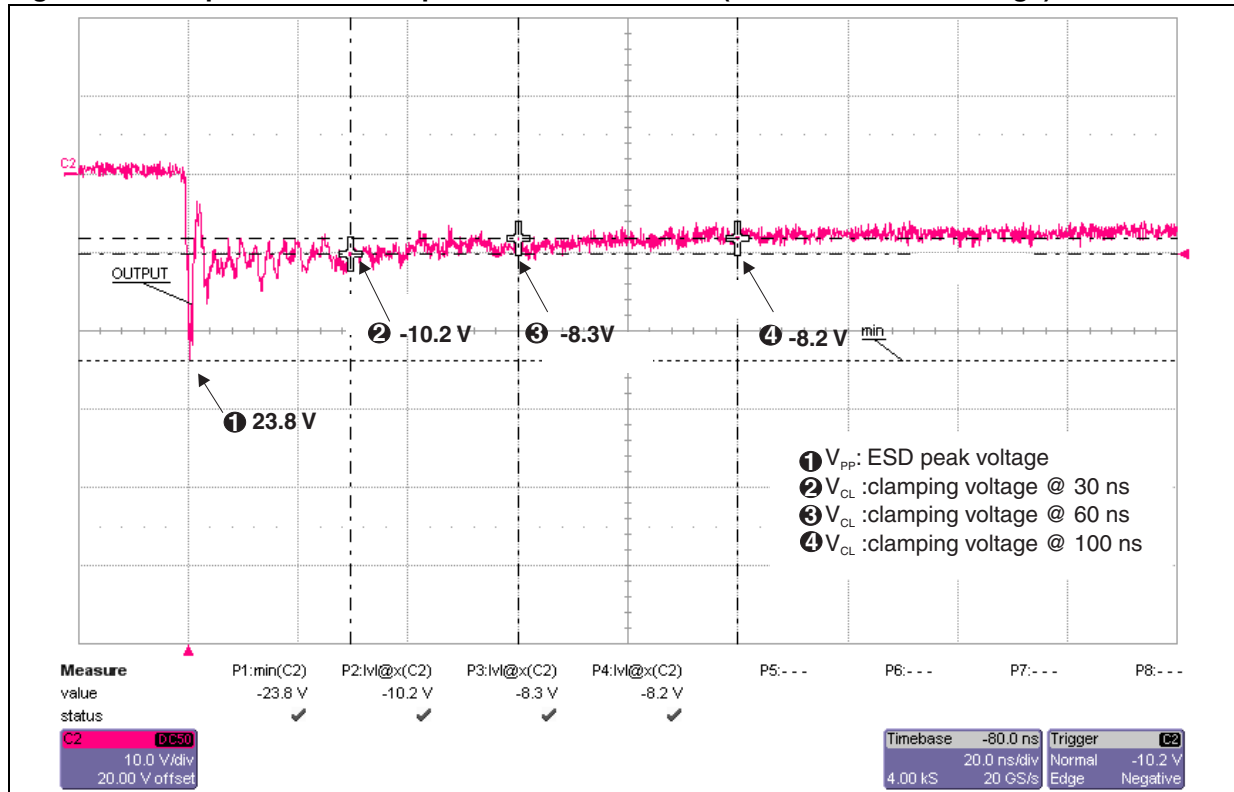

Figure 12. Output filter ESD response to IEC 61000-4-2 (+30 kV contact discharge) I1 to O1

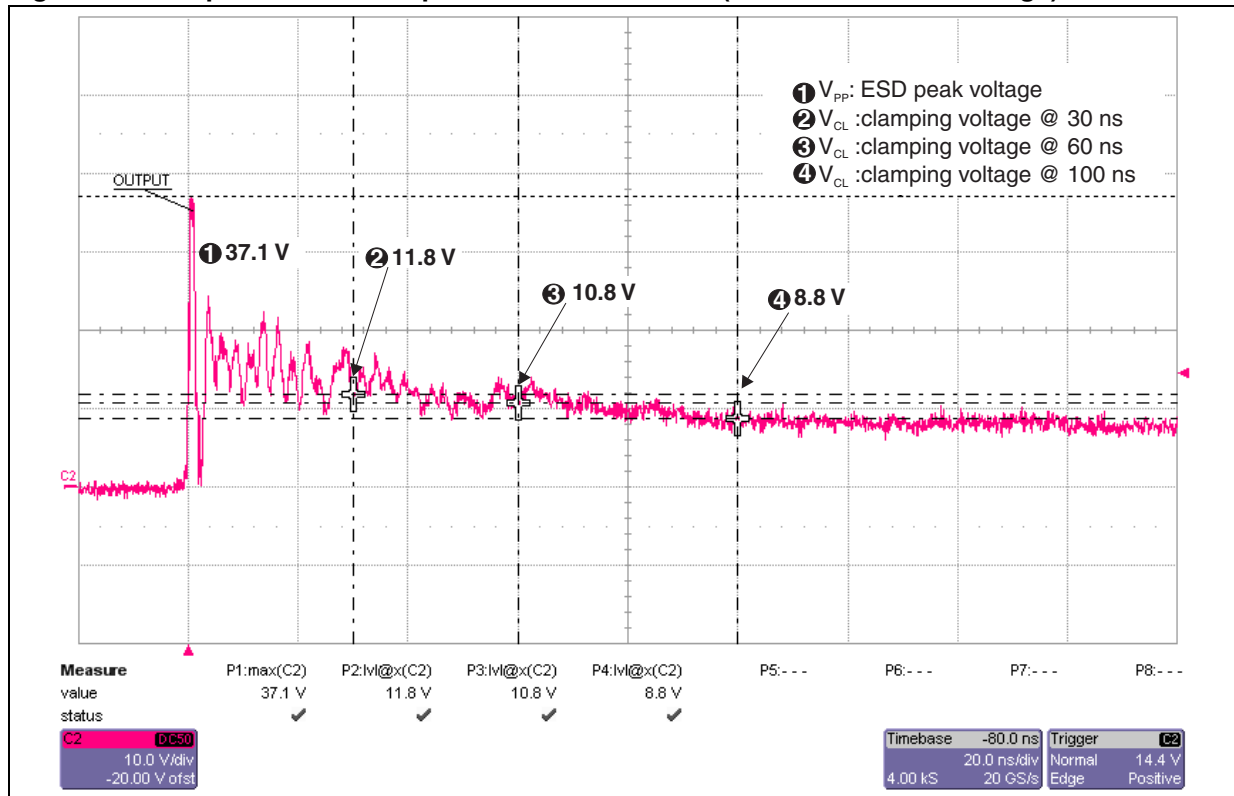
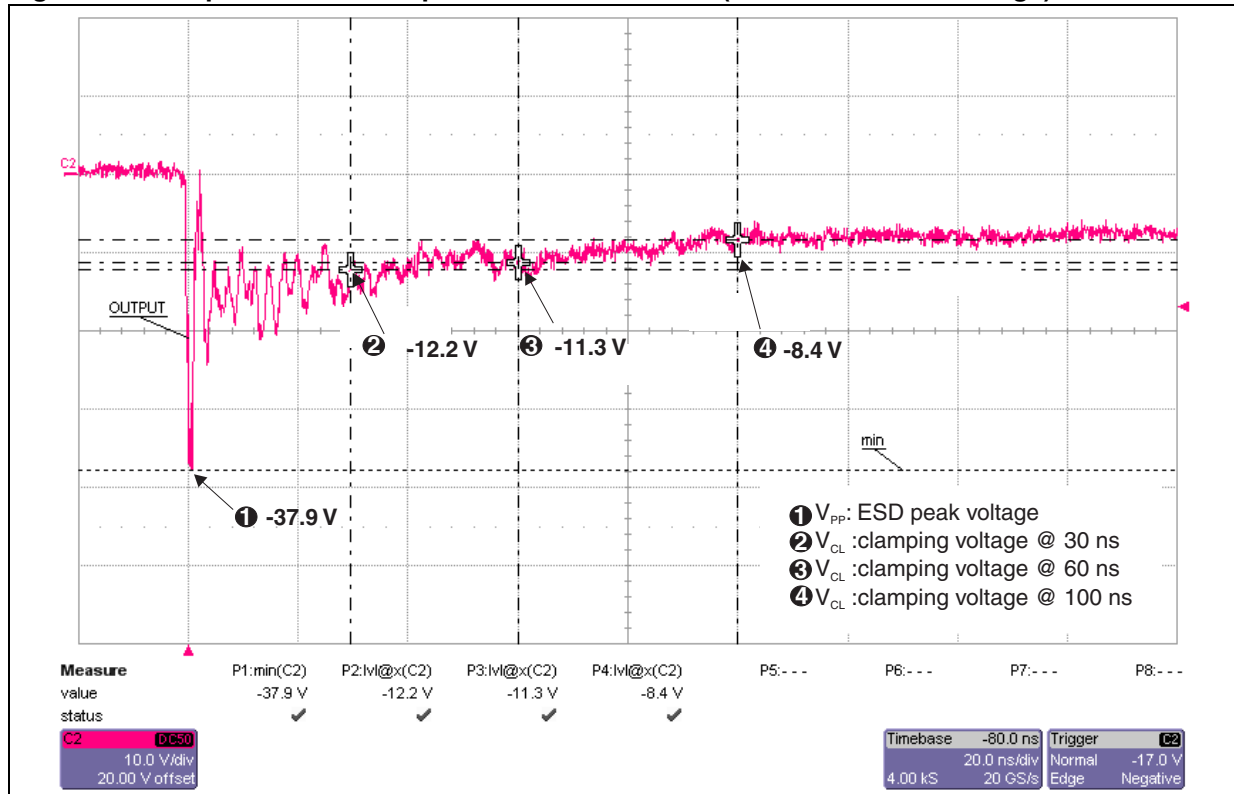
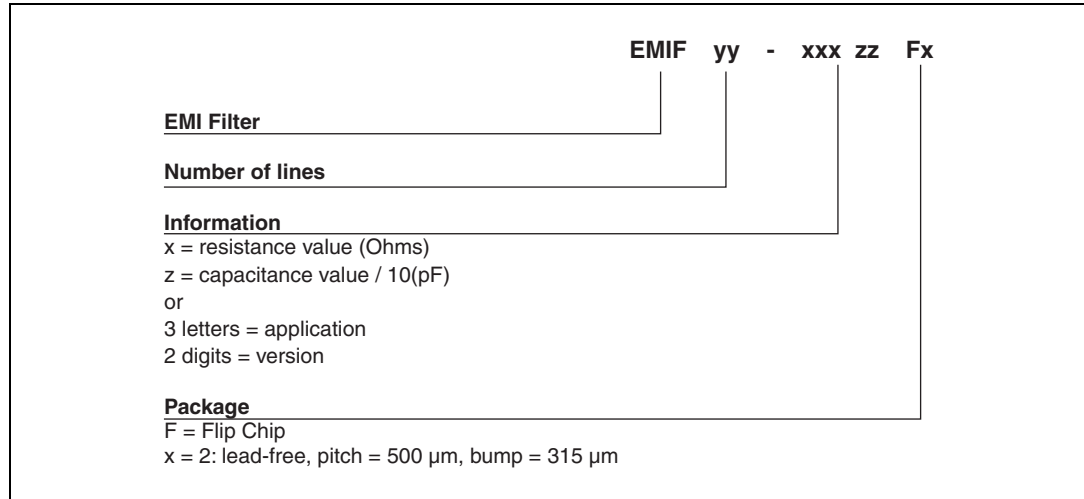

Figure 13. Output filter ESD response to IEC 61000-4-2 (-30 kV contact discharge) I1 to O1



## 2 Ordering information scheme

Figure 14. Ordering information scheme



### 3 Package information

In order to meet environmental requirements, ST offers these devices in different grades of ECOPACK® packages, depending on their level of environmental compliance. ECOPACK® specifications, grade definitions and product status are available at: [www.st.com](http://www.st.com). ECOPACK® is an ST trademark.

Figure 15. Package dimensions

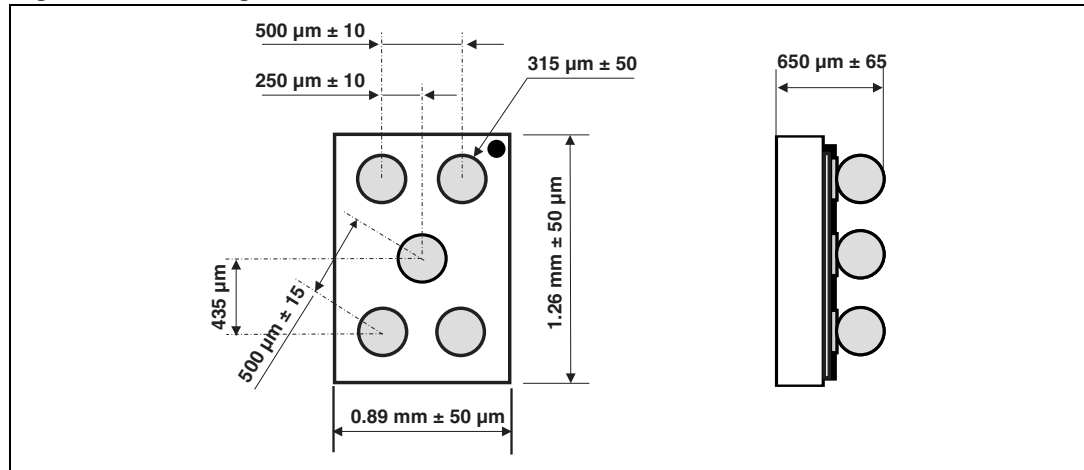

Figure 16. Footprint

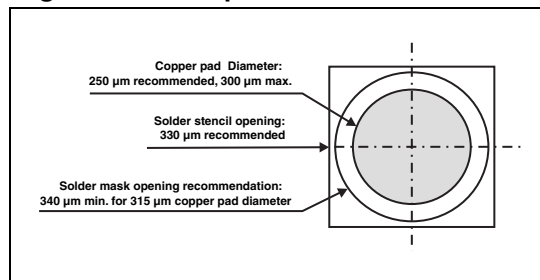

Figure 17. Marking

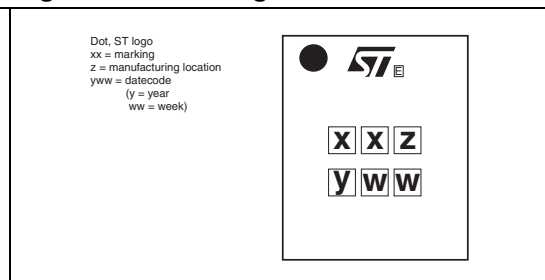
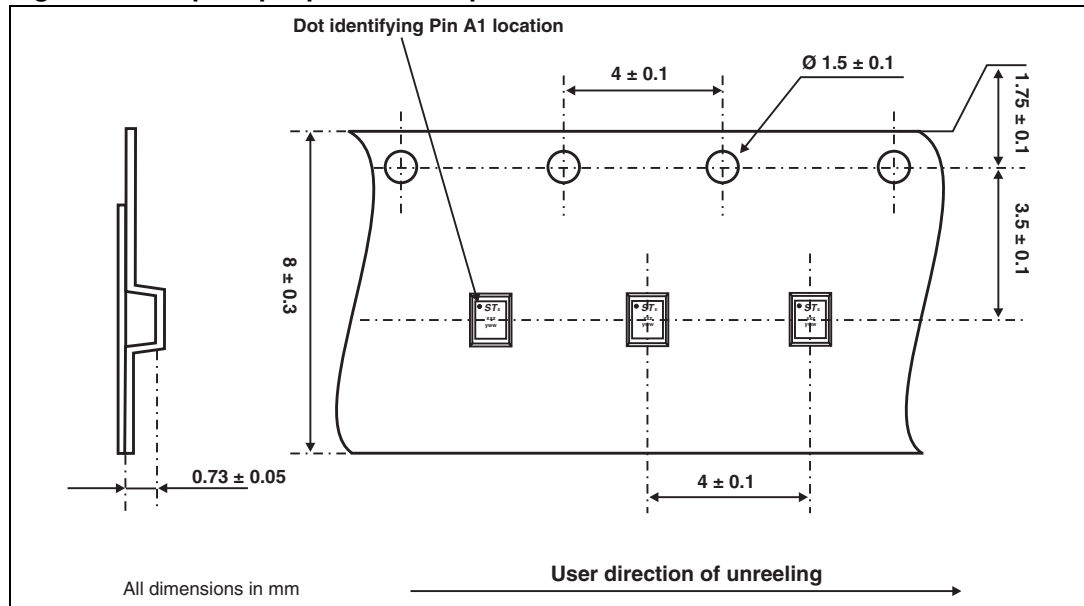

Figure 18. Flip Chip tape and reel specification



Note: More information is available in the application notes:  
AN1235: "Flip Chip: Package description and recommendations for use"  
AN1751: "EMI filters: Recommendations and measurements"

## 4 Ordering information

Table 3. Ordering information

Order code	Marking	Package	Weight	Base qty	Delivery mode
EMIF02-SPK02F2	JD	Flip Chip	1.8 mg	5000	Tape and reel 7"

## 5 Revision history

Table 4. Document revision history

Date	Revision	Changes
17-Sep-2008	1	Initial release.
12-Sep-2011	2	Updated <a href="#">Figure 15</a> and <a href="#">Figure 16</a> .
3-Apr-2012	3	Updated cover page features and description. Inserted <a href="#">Figure 6</a> to <a href="#">Figure 13</a> .

**Please Read Carefully:**

Information in this document is provided solely in connection with ST products. STMicroelectronics NV and its subsidiaries ("ST") reserve the right to make changes, corrections, modifications or improvements, to this document, and the products and services described herein at any time, without notice.

All ST products are sold pursuant to ST's terms and conditions of sale.

Purchasers are solely responsible for the choice, selection and use of the ST products and services described herein, and ST assumes no liability whatsoever relating to the choice, selection or use of the ST products and services described herein.

No license, express or implied, by estoppel or otherwise, to any intellectual property rights is granted under this document. If any part of this document refers to any third party products or services it shall not be deemed a license grant by ST for the use of such third party products or services, or any intellectual property contained therein or considered as a warranty covering the use in any manner whatsoever of such third party products or services or any intellectual property contained therein.

**UNLESS OTHERWISE SET FORTH IN ST'S TERMS AND CONDITIONS OF SALE ST DISCLAIMS ANY EXPRESS OR IMPLIED WARRANTY WITH RESPECT TO THE USE AND/OR SALE OF ST PRODUCTS INCLUDING WITHOUT LIMITATION IMPLIED WARRANTIES OF MERCHANTABILITY, FITNESS FOR A PARTICULAR PURPOSE (AND THEIR EQUIVALENTS UNDER THE LAWS OF ANY JURISDICTION), OR INFRINGEMENT OF ANY PATENT, COPYRIGHT OR OTHER INTELLECTUAL PROPERTY RIGHT.**

**UNLESS EXPRESSLY APPROVED IN WRITING BY TWO AUTHORIZED ST REPRESENTATIVES, ST PRODUCTS ARE NOT RECOMMENDED, AUTHORIZED OR WARRANTED FOR USE IN MILITARY, AIR CRAFT, SPACE, LIFE SAVING, OR LIFE SUSTAINING APPLICATIONS, NOR IN PRODUCTS OR SYSTEMS WHERE FAILURE OR MALFUNCTION MAY RESULT IN PERSONAL INJURY, DEATH, OR SEVERE PROPERTY OR ENVIRONMENTAL DAMAGE. ST PRODUCTS WHICH ARE NOT SPECIFIED AS "AUTOMOTIVE GRADE" MAY ONLY BE USED IN AUTOMOTIVE APPLICATIONS AT USER'S OWN RISK.**

Resale of ST products with provisions different from the statements and/or technical features set forth in this document shall immediately void any warranty granted by ST for the ST product or service described herein and shall not create or extend in any manner whatsoever, any liability of ST.

ST and the ST logo are trademarks or registered trademarks of ST in various countries.

Information in this document supersedes and replaces all information previously supplied.

The ST logo is a registered trademark of STMicroelectronics. All other names are the property of their respective owners.

© 2012 STMicroelectronics - All rights reserved

STMicroelectronics group of companies

Australia - Belgium - Brazil - Canada - China - Czech Republic - Finland - France - Germany - Hong Kong - India - Israel - Italy - Japan - Malaysia - Malta - Morocco - Philippines - Singapore - Spain - Sweden - Switzerland - United Kingdom - United States of America

[www.st.com](http://www.st.com)

## Looking for pricing, stock, or lifecycle information?

Click below to explore more details on WIN SOURCE:

- ⊖ [View EMIF02-SPK02F2 on WIN SOURCE](#)
- ⊖ [STMicroelectronics](#) Information

## Optimize Your Supply Chain with WIN SOURCE Solutions

- ✓ Global Sourcing Solution
- ✓ Obsolete Management
- ✓ Cost Control Management
- ✓ Shortage Management
- ✓ Alternative Solution
- ✓ Excess Inventory Management