



RPM-Based Fan Controller with Multiple Temperature Zones & Hardware Thermal Shutdown

PRODUCT FEATURES

Data Brief

General Description

The EMC2113 is an SMBus compliant fan controller. The fan driver can be operated using two methods, each with two modes. The methods include an RPM-based Fan Speed Control Algorithm and a direct PWM drive setting. The modes include manually programming the desired settings or using the internal programmable temperature look-up table to select the desired setting based on measured temperature.

The EMC2113 includes a temperature monitor that measures up to three (3) external diodes and the internal diode. The temperature monitors offer 1°C accuracy (for external diodes) with sophisticated features to reduce errors introduced by series resistance and beta variation of substrate thermal diode transistors commonly found in processors.

The device includes high and low limits for all temperature channels as well as a hardware set critical temperature limit. This hardware set limit drives a dedicated system shutdown pin.

Finally, the device includes an open-drain, active low interrupt pin to flag temperature or fan control errors.

Applications

- Notebook Computers
- Projectors
- Graphics Cards
- Industrial and Networking Equipment

Features

- Programmable Fan Control circuit
 - 4-wire fan compatible
 - Both Low and High frequency PWM
- RPM-based fan control algorithm
 - 2% accurate from 500 RPM to 16k RPM
 - Automatic Tachometer feedback
- Temperature Look-Up Table
 - Controls fan speed or PWM drive setting
 - Eight steps that incorporate up to four temperature zones simultaneously (user selectable)
 - Supports forced DTS or standard temperature data
 - Allows external PWM input (150Hz to 40kHz)
- Up to Three External Temperature Channels
 - Supports transistor model for 90nm - 45nm Intel CPUs
 - Resistance Error Correction and Beta Compensation
 - 1°C accurate (60°C to 125°C)
 - 0.125°C resolution
 - Programmable High and Low limits
- Hardware Programmable Thermal Shutdown Temperature
 - Cannot be altered by software
 - 65°C to 127°C Range
 - Dedicated system shutdown interrupt pin
- Internal Temperature Monitor
 - ±1°C accuracy
 - 0.125°C resolution
- 3.3V Supply Voltage
- Open drain interrupt pin
- SMBus 2.0 Interface
 - SMBus Alert compatible
 - Selectable SMBus Address via pull-up resistor and ADDR_SEL pin
 - Block Read and Write
- Available in 16-pin 4mm x 4mm QFN Lead-free RoHS Compliant package

ORDER NUMBER(S):

ORDERING NUMBER	PACKAGE	FEATURES
EMC2113-1-AP-TR	16-pin 4mm x4mm QFN (Lead-free ROHS Compliant)	RPM-based Fan Speed Control Algorithm, High Frequency PWM driver, HW Thermal / Critical shutdown

**This product meets the halogen maximum concentration values per IEC61249-2-21
For RoHS compliance and environmental information, please visit www.smSC.com/rohs**



80 ARKAY DRIVE, HAUPPAUGE, NY 11788 (631) 435-6000, FAX (631) 273-3123

Copyright © 2009 SMSC or its subsidiaries. All rights reserved.

Circuit diagrams and other information relating to SMSC products are included as a means of illustrating typical applications. Consequently, complete information sufficient for construction purposes is not necessarily given. Although the information has been checked and is believed to be accurate, no responsibility is assumed for inaccuracies. SMSC reserves the right to make changes to specifications and product descriptions at any time without notice. Contact your local SMSC sales office to obtain the latest specifications before placing your product order. The provision of this information does not convey to the purchaser of the described semiconductor devices any licenses under any patent rights or other intellectual property rights of SMSC or others. All sales are expressly conditional on your agreement to the terms and conditions of the most recently dated version of SMSC's standard Terms of Sale Agreement dated before the date of your order (the "Terms of Sale Agreement"). The product may contain design defects or errors known as anomalies which may cause the product's functions to deviate from published specifications. Anomaly sheets are available upon request. SMSC products are not designed, intended, authorized or warranted for use in any life support or other application where product failure could cause or contribute to personal injury or severe property damage. Any and all such uses without prior written approval of an Officer of SMSC and further testing and/or modification will be fully at the risk of the customer. Copies of this document or other SMSC literature, as well as the Terms of Sale Agreement, may be obtained by visiting SMSC's website at <http://www.smSC.com>. SMSC is a registered trademark of Standard Microsystems Corporation ("SMSC"). Product names and company names are the trademarks of their respective holders.

SMSC DISCLAIMS AND EXCLUDES ANY AND ALL WARRANTIES, INCLUDING WITHOUT LIMITATION ANY AND ALL IMPLIED WARRANTIES OF MERCHANTABILITY, FITNESS FOR A PARTICULAR PURPOSE, TITLE, AND AGAINST INFRINGEMENT AND THE LIKE, AND ANY AND ALL WARRANTIES ARISING FROM ANY COURSE OF DEALING OR USAGE OF TRADE. IN NO EVENT SHALL SMSC BE LIABLE FOR ANY DIRECT, INCIDENTAL, INDIRECT, SPECIAL, PUNITIVE, OR CONSEQUENTIAL DAMAGES; OR FOR LOST DATA, PROFITS, SAVINGS OR REVENUES OF ANY KIND; REGARDLESS OF THE FORM OF ACTION, WHETHER BASED ON CONTRACT; TORT; NEGLIGENCE OF SMSC OR OTHERS; STRICT LIABILITY; BREACH OF WARRANTY; OR OTHERWISE; WHETHER OR NOT ANY REMEDY OF BUYER IS HELD TO HAVE FAILED OF ITS ESSENTIAL PURPOSE, AND WHETHER OR NOT SMSC HAS BEEN ADVISED OF THE POSSIBILITY OF SUCH DAMAGES.

Block Diagram

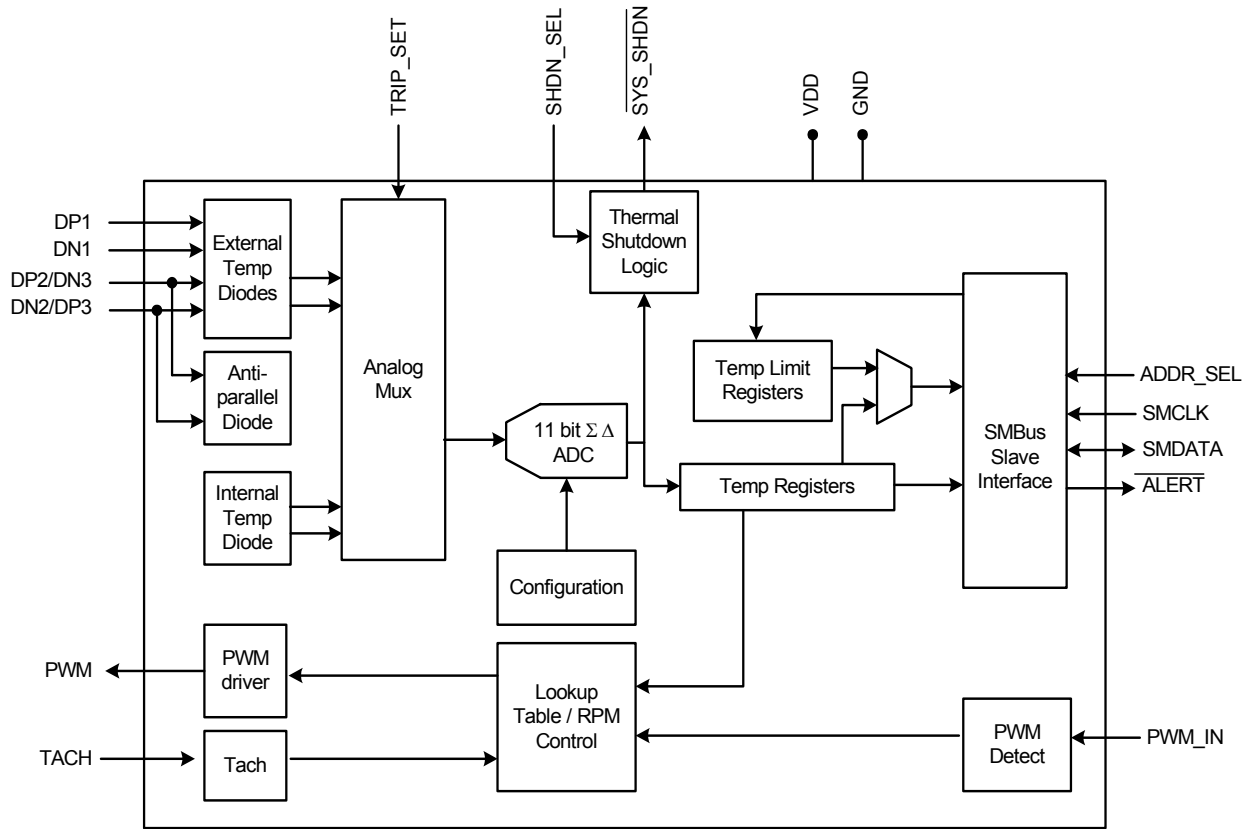

Figure 1 EMC2113 Block Diagram

Package Outline

EMC2113 Package Information

COMMON DIMENSIONS					
SYMBOL	MIN	NOM	MAX	NOTE	REMARK
A	0.80	0.85	0.90	-	OVERALL PACKAGE HEIGHT
A1	0	0.02	0.05	-	STANDOFF
A3	0.20 REF			-	LEAD-FRAME THICKNESS
D/E	3.90	4.00	4.10	-	X/Y BODY SIZE
D2/E2	2.00	2.10	2.20	2	X/Y EXPOSED PAD SIZE
L	0.45	0.50	0.55	-	TERMINAL LENGTH
b	0.25	0.30	0.35	2	TERMINAL WIDTH
K	0.20	-	-	-	TERMINAL TO PAD DISTANCE
e	0.65 BSC			-	TERMINAL PITCH

NOTES:

1. ALL DIMENSIONS ARE IN MILLIMETERS.
2. POSITION TOLERANCE OF EACH TERMINAL AND EXPOSED PAD IS $\pm 0.05\text{mm}$ AT MAXIMUM MATERIAL CONDITION. DIMENSIONS "b" APPLIES TO PLATED TERMINALS AND IT IS MEASURED BETWEEN 0.15 AND 0.30 mm FROM THE TERMINAL TIP.
3. DETAILS OF TERMINAL #1 IDENTIFIER ARE OPTIONAL BUT MUST BE LOCATED WITHIN THE AREA INDICATED.

Figure 2 16-Pin QFN 4mm x 4mm Package Dimensions

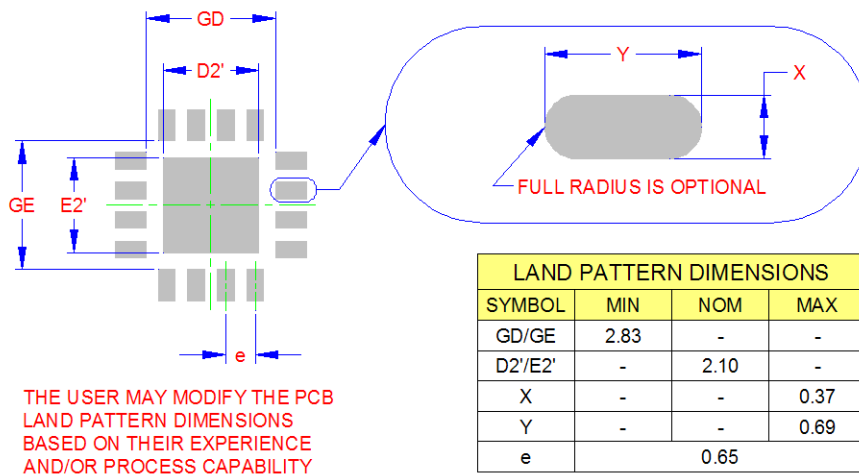

RECOMMENDED PCB LAND PATTERN

Figure 3 16-Pin QFN 4mm x 4mm PCB Footprint

Looking for pricing, stock, or lifecycle information?

Click below to explore more details on WIN SOURCE:

- ⊖ [View EMC2113-1-AP-TR on WIN SOURCE](#)
- ⊖ [Microchip Technology](#) Information

Optimize Your Supply Chain with WIN SOURCE Solutions

- ✓ Global Sourcing Solution
- ✓ Obsolete Management
- ✓ Cost Control Management
- ✓ Shortage Management
- ✓ Alternative Solution
- ✓ Excess Inventory Management