



**THE DATASHEET OF
1ED020I12FA**



1ED020I12FA2

Single IGBT Driver IC
SP001080574



1 Overview

Main Features

- Single channel isolated IGBT Driver
- For 600V/1200V IGBTs
- 2 A rail-to-rail output
- Vcesat-detection
- Active Miller Clamp



Product Highlights

- Coreless transformer isolated driver
- Basic insulation according to DIN EN 60747-5-2
- Basic insulation recognized under UL 1577
- Integrated protection features
- Suitable for operation at high ambient temperature
- AEC Qualified

Typical Application

- Drive inverters for HEV and EV
- Auxiliary inverters for HEV and EV
- High Power DC/DC inverters

Description

The 1ED020I12FA2 is a galvanic isolated single channel IGBT driver in PG-DSO-20 package that provides an output current capability of typically 2A.

All logic pins are 5V CMOS compatible and could be directly connected to a microcontroller.

The data transfer across galvanic isolation is realized by the integrated Coreless Transformer Technology.

The 1ED020I12FA2 provides several protection features like IGBT desaturation protection, active Miller clamping and active shut down.

Type	Package	Marking
1ED020I12FA2	PG-DSO-20	1ED020I12FA2

Table of Contents

1	Overview	1
	Table of Contents	2
	List of Figures	3
	List of Tables	4
2	Block Diagram	5
3	Pin Configuration and Functionality	6
3.1	Pin Configuration	6
3.2	Pin Functionality	7
4	Functional Description	9
4.1	Introduction	9
4.2	Supply	9
4.3	Internal Protection Features	10
4.3.1	Undervoltage Lockout (UVLO)	10
4.3.2	READY Status Output	10
4.3.3	Watchdog Timer	10
4.3.4	Active Shut-Down	11
4.4	Non-Inverting and Inverting Inputs	11
4.5	Driver Output	11
4.6	External Protection Features	11
4.6.1	Desaturation Protection	11
4.6.2	Active Miller Clamp	11
4.6.3	Short Circuit Clamping	11
4.7	RESET	11
5	Electrical Parameters	12
5.1	Absolute Maximum Ratings	12
5.2	Operating Parameters	13
5.3	Recommended Operating Parameters	13
5.4	Electrical Characteristics	14
5.4.1	Voltage Supply	14
5.4.2	Logic Input and Output	15
5.4.3	Gate Driver	16
5.4.4	Active Miller Clamp	16
5.4.5	Short Circuit Clamping	17
5.4.6	Dynamic Characteristics	17
5.4.7	Desaturation Protection	18
5.4.8	Active Shut Down	20
6	Insulation Characteristics	21
6.1	Certified according to DIN EN 60747-5-2 (VDE 0884 Teil 2): 2003-01. Basic Insulation	21
6.2	Recognized under UL 1577	21
6.3	Reliability	21
7	Timing Diagrams	22
8	Package Outlines	24
9	Application Notes	25
9.1	Reference Layout for Thermal Data	25
9.2	Printed Circuit Board Guidelines	25

List of Figures

Figure 1	Block Diagram 1ED020I12FA2.....	5
Figure 2	PG-DSO-20 (top view)	7
Figure 3	Application Example Bipolar Supply	9
Figure 4	Application Example Unipolar Supply	10
Figure 5	Propagation Delay, Rise and Fall Time	22
Figure 6	Typical Switching Behavior.....	22
Figure 7	DESAT Switch-Off Behavior.....	23
Figure 8	UVLO Behavior.....	23
Figure 9	PG-DSO-20 (Plastic (Green) Dual Small Outline Package)	24
Figure 10	Reference Layout for Thermal Data (Copper thickness 102 μm).....	25

List of Tables

Table 1	Pin Configuration	6
Table 2	Absolute Maximum Ratings	12
Table 3	Operating Parameters	13
Table 4	Recommended Operating Parameters	13
Table 5	Voltage Supply	14
Table 6	Logic Input and Output	15
Table 7	Gate Driver	16
Table 8	Active Miller Clamp	16
Table 9	Short Circuit Clamping	17
Table 10	Dynamic Characteristics	17
Table 11	Desaturation Protection	18
Table 12	Active Shut Down	20
Table 13	According to DIN EN 60747-5-2	21
Table 14	Recognized under UL 1577	21

Block Diagram

2 Block Diagram

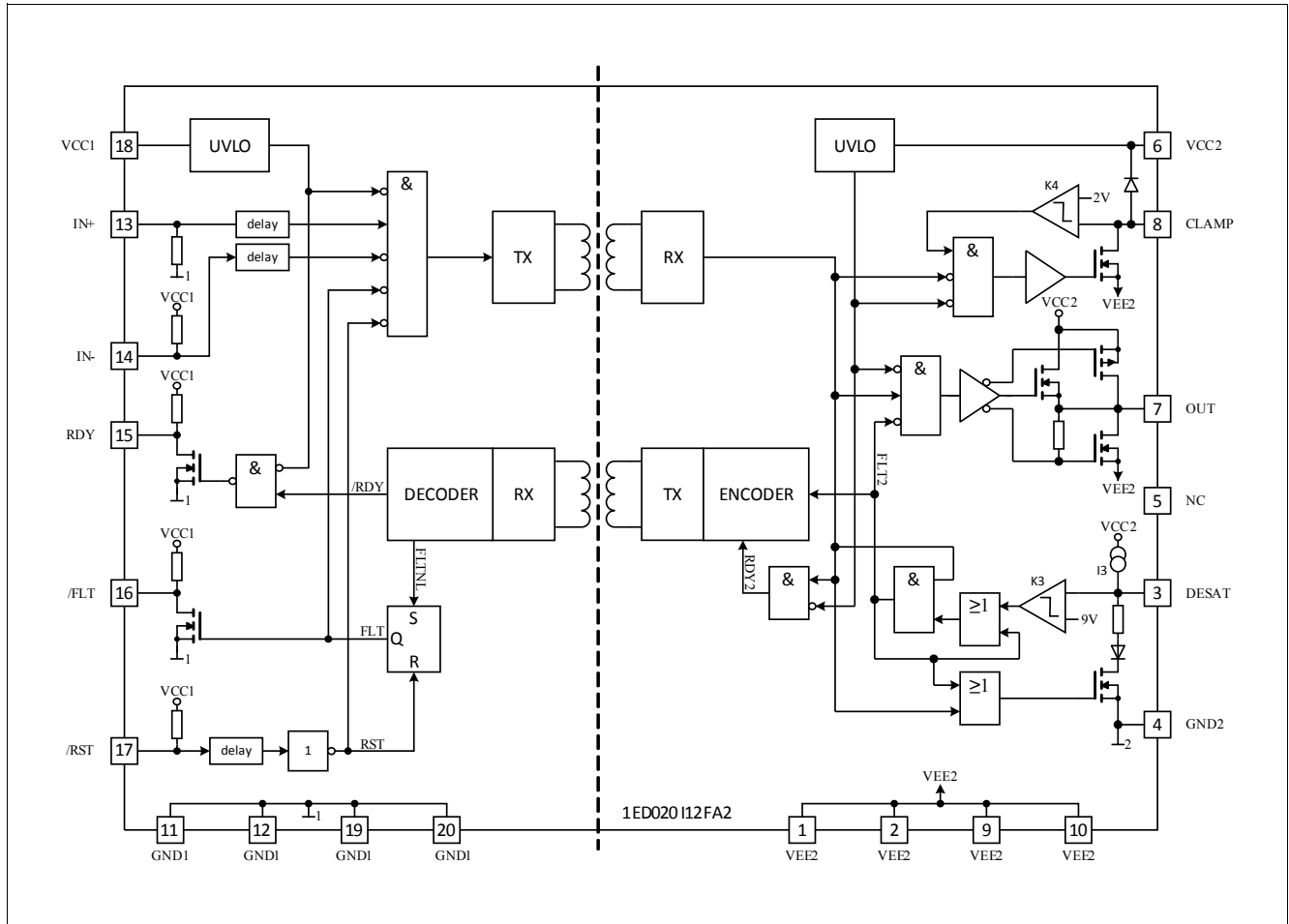

Figure 1 Block Diagram 1ED020I12FA2

3 Pin Configuration and Functionality

3.1 Pin Configuration

Table 1 Pin Configuration

Pin No.	Name	Function
1	VEE2	Negative power supply output side
2	VEE2	Negative power supply output side
3	DESAT	Desaturation protection
4	GND2	Signal ground output side
5	NC	Not connected
6	VCC2	Positive power supply output side
7	OUT	Driver output
8	CLAMP	Miller clamping
9	VEE2	Negative power supply output side
10	VEE2	Negative power supply output side
11	GND1	Ground input side
12	GND1	Ground input side
13	IN+	Non inverted driver input
14	IN-	Inverted driver input
15	RDY	Ready output
16	/FLT	Fault output, low active
17	/RST	Reset input, low active
18	VCC1	Positive power supply input side
19	GND1	Ground input side
20	GND1	Ground input side

Pin Configuration and Functionality

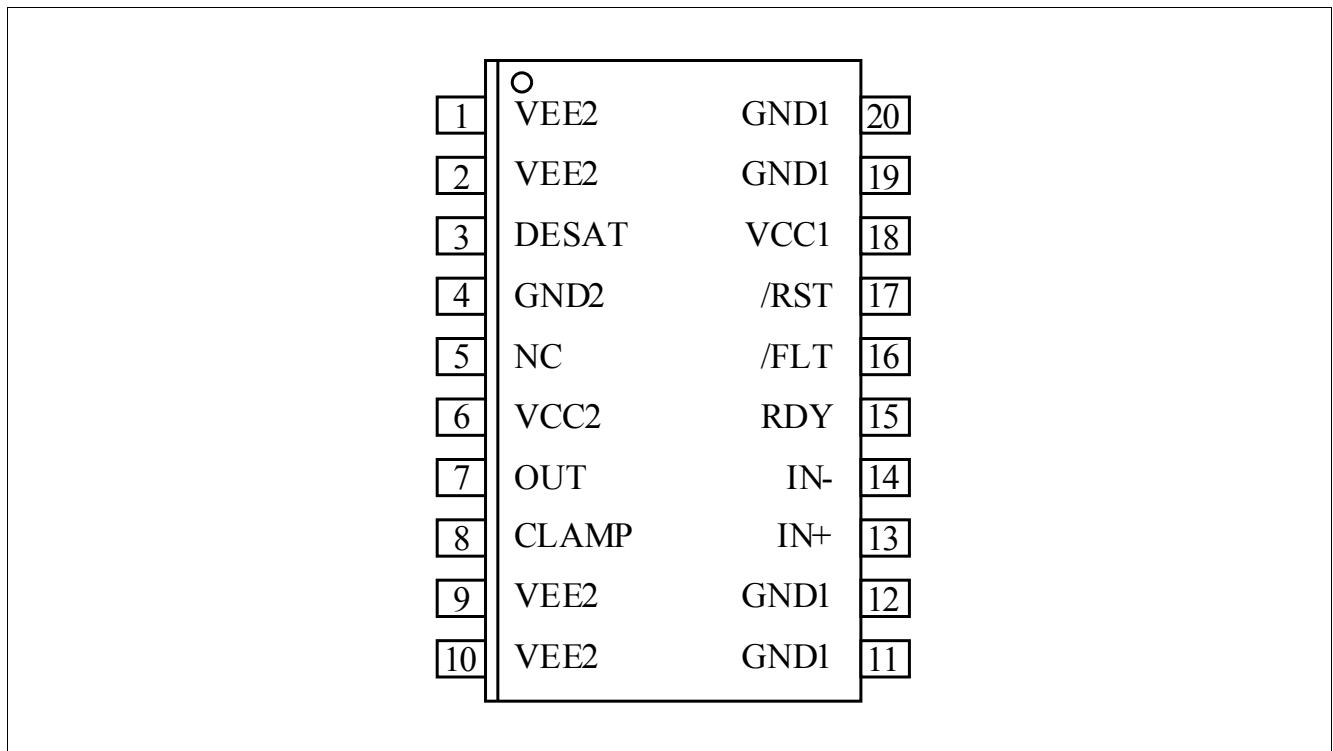

Figure 2 PG-DSO-20 (top view)

3.2 Pin Functionality

GND1

Ground connection of the input side.

IN+ Non Inverting Driver Input

IN+ control signal for the driver output if IN- is set to low. (The IGBT is on if IN+ = high and IN- = low)

A minimum pulse width is defined to make the IC robust against glitches at IN+. An internal Pull-Down-Resistor ensures IGBT Off-State.

IN- Inverting Driver Input

IN- control signal for driver output if IN+ is set to high. (IGBT is on if IN- = low and IN+ = high)

A minimum pulse width is defined to make the IC robust against glitches at IN-. An internal Pull-Up-Resistor ensures IGBT Off-State.

/RST Reset Input

Function 1: Enable/shutdown of the input chip. (The IGBT is off if /RST = low). A minimum pulse width is defined to make the IC robust against glitches at /RST.

Function 2: Resets the DESAT-FAULT-state of the chip if /RST is low for a time T_{RST} . An internal Pull-Up-Resistor is used to ensure /FLT status output.

/FLT Fault Output

Open-drain output to report a desaturation error of the IGBT (FLT is low if desaturation occurs)

Pin Configuration and Functionality

RDY Ready Status

Open-drain output to report the correct operation of the device (RDY = high if both chips are above the UVLO level and the internal chip transmission is faultless).

VCC1

5 V power supply of the input chip

VEE2

Negative power supply pins of the output chip. If no negative supply voltage is available, all VEE2 pins have to be connected to GND2.

DESAT Desaturation Detection Input

Monitoring of the IGBT saturation voltage (V_{CE}) to detect desaturation caused by short circuits. If OUT is high, V_{CE} is above a defined value and a certain blanking time has expired, the desaturation protection is activated and the IGBT is switched off. The blanking time is adjustable by an external capacitor.

CLAMP Miller Clamping

Ties the gate voltage to ground after the IGBT has been switched off at a defined voltage to avoid a parasitic switch-on of the IGBT. During turn-off, the gate voltage is monitored and the clamp output is activated when the gate voltage goes below 2 V below VEE2.

GND2 Reference Ground

Reference ground of the output chip.

OUT Driver Output

Output pin to drive an IGBT. The voltage is switched between VEE2 and VCC2. In normal operating mode Vout is controlled by IN+, IN- and /RST. During error mode (UVLO, internal error or DESAT) Vout is set to VEE2 independent of the input control signals.

VCC2

Positive power supply pin of the output side.

4 Functional Description

4.1 Introduction

The 1ED020I12FA2 is an advanced IGBT gate driver that can be also used for driving power MOS devices. Control and protection functions are included to make possible the design of high reliability systems.

The device consists of two galvanic separated parts. The input chip can be directly connected to a standard 5 V DSP or microcontroller with CMOS in/output and the output chip is connected to the high voltage side.

The rail-to-rail driver output enables the user to provide easy clamping of the IGBTs gate voltage during short circuit of the IGBT. So an increase of short circuit current due to the feedback via the Miller capacitance can be avoided. Further, a rail-to-rail output reduces power dissipation.

The device also includes IGBT desaturation protection with FAULT status output.

The READY status output reports if the device is supplied and operates correctly.

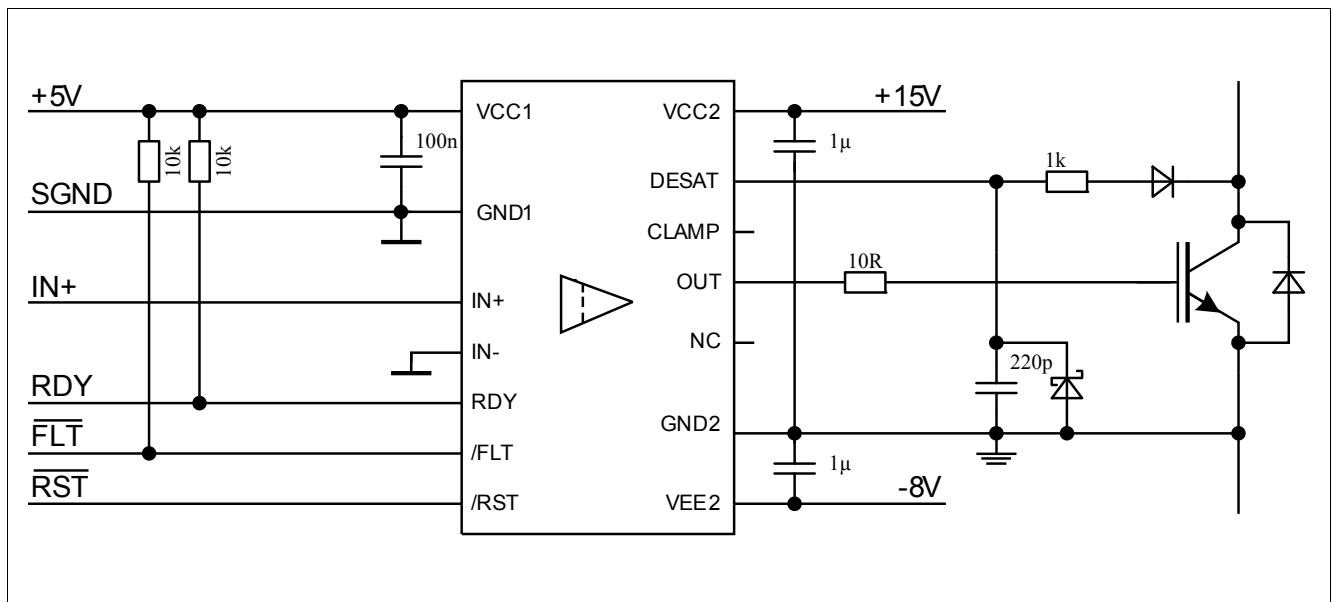

Figure 3 Application Example Bipolar Supply

4.2 Supply

The driver 1ED020I12FA2 is designed to support two different supply configurations, bipolar supply and unipolar supply.

In bipolar supply the driver is typically supplied with a positive voltage of 15V at VCC2 and a negative voltage of -8V at VEE2, please refer to [Figure 3](#). Negative supply prevents a dynamic turn on due to the additional charge which is generated from IGBT input capacitance times negative supply voltage. If an appropriate negative supply voltage is used, connecting CLAMP to IGBT gate is redundant and therefore typically not necessary.

For unipolar supply configuration the driver is typically supplied with a positive voltage of 15V at VCC2. Erratically dynamic turn on of the IGBT could be prevented with active Miller clamp function, so CLAMP output is directly connected to IGBT gate, please refer to [Figure 4](#).

Functional Description

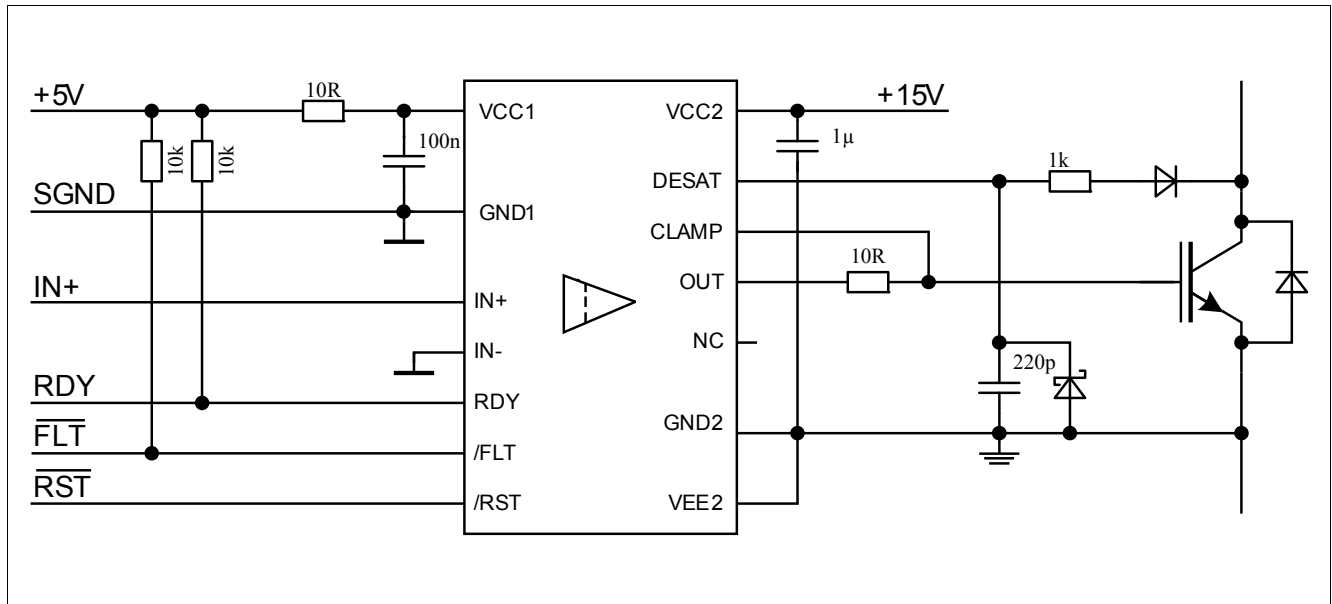

Figure 4 Application Example Unipolar Supply

4.3 Internal Protection Features

4.3.1 Undervoltage Lockout (UVLO)

To ensure correct switching of IGBTs the device is equipped with an undervoltage lockout for both chips, refer to [Figure 8](#).

If the power supply voltage V_{VCC1} of the input chip drops below V_{UVLOL1} a turn-off signal is sent to the output chip before power-down. The IGBT is switched off and the signals at IN+ and IN- are ignored as long as V_{VCC1} reaches the power-up voltage V_{UVLOH1} .

If the power supply voltage V_{VCC2} of the output chip goes down below V_{UVLOL2} the IGBT is switched off and signals from the input chip are ignored as long as V_{VCC2} reaches the power-up voltage V_{UVLOH2} . VEE2 is not monitored, otherwise negative supply voltage range from 0 V to -12 V would not be possible.

4.3.2 READY Status Output

The READY output shows the status of three internal protection features.

- UVLO of the input chip
- UVLO of the output chip after a short delay
- Internal signal transmission after a short delay

It is not necessary to reset the READY signal since its state only depends on the status of the former mentioned protection signals.

4.3.3 Watchdog Timer

During normal operation the internal signal transmission is monitored by a watchdog timer. If the transmission fails for a given time, the IGBT is switched off and the READY output reports an internal error.

Functional Description

4.3.4 Active Shut-Down

The Active Shut-Down feature ensures a safe IGBT off-state if the output chip is not connected to the power supply, IGBT gate is clamped at OUT to VEE2.

4.4 Non-Inverting and Inverting Inputs

There are two possible input modes to control the IGBT. At non-inverting mode IN+ controls the driver output while IN- is set to low. At inverting mode IN- controls the driver output while IN+ is set to high, please see [Figure 6](#). A minimum input pulse width is defined to filter occasional glitches.

4.5 Driver Output

The output driver sections uses only MOSFETs to provide a rail-to-rail output. This feature permits that tight control of gate voltage during on-state and short circuit can be maintained as long as the drivers supply is stable. Due to the low internal voltage drop, switching behaviour of the IGBT is predominantly governed by the gate resistor. Furthermore, it reduces the power to be dissipated by the driver.

4.6 External Protection Features

4.6.1 Desaturation Protection

A desaturation protection ensures the protection of the IGBT at short circuit. When the DESAT voltage goes up and reaches 9 V, the output is driven low. Further, the FAULT output is activated, please refer to [Figure 7](#). A programmable blanking time is used to allow enough time for IGBT saturation. Blanking time is provided by a highly precise internal current source and an external capacitor.

4.6.2 Active Miller Clamp

In a half bridge configuration the switched off IGBT tends to dynamically turn on during turn on phase of the opposite IGBT. A Miller clamp allows sinking the Miller current across a low impedance path in this high dV/dt situation. Therefore in many applications, the use of a negative supply voltage can be avoided.

During turn-off, the gate voltage is monitored and the clamp output is activated when the gate voltage goes below typical 2 V (related to VEE2). The clamp is designed for a Miller current up to 2 A.

4.6.3 Short Circuit Clamping

During short circuit the IGBTs gate voltage tends to rise because of the feedback via the Miller capacitance. An additional protection circuit connected to OUT and CLAMP limits this voltage to a value slightly higher than the supply voltage. A current of maximum 500 mA for 10 μ s may be fed back to the supply through one of this paths. If higher currents are expected or a tighter clamping is desired external Schottky diodes may be added.

4.7 RESET

The reset inputs have two functions.

Firstly, /RST is in charge of setting back the FAULT output. If /RST is low longer than a given time, /FLT will be cleared at the rising edge of /RST, refer to [Figure 7](#); otherwise, it will remain unchanged. Moreover, it works as enable/shutdown of the input logic, refer to [Figure 6](#).

Electrical Parameters

5 Electrical Parameters

5.1 Absolute Maximum Ratings

Note: Absolute maximum ratings are defined as ratings, which when being exceeded may lead to destruction of the integrated circuit. Unless otherwise noted all parameters refer to GND1.

Table 2 Absolute Maximum Ratings

Parameter	Symbol	Values		Unit	Note
		Min.	Max.		
Positive power supply output side	V_{VCC2}	-0.3	20	V	1)
Negative power supply output side	V_{VEE2}	-12	0.3	V	1)
Maximum power supply voltage output side ($V_{VCC2} - V_{VEE2}$)	V_{max2}	-	28	V	-
Gate driver output	V_{OUT}	$V_{VEE2}-0.3$	$V_{VCC2}+0.3$	V	-
Gate driver high output maximum current	I_{OUT}	-	2.4	A	$t = 2 \mu s$
Gate & Clamp driver low output maximum current	I_{OUT}	-	2.4	A	$t = 2 \mu s$
Maximum short circuit clamping time	t_{CLP}	-	10	μs	$I_{CLAMP/OUT} = 500 \text{ mA}$
Positive power supply input side	V_{VCC1}	-0.3	6.5	V	-
Logic input voltages (IN+, IN-, RST)	$V_{LogicIN}$	-0.3	6.5	V	-
Opendrain Logic output voltage (\overline{FLT})	$V_{FLT\#}$	-0.3	6.5	V	-
Opendrain Logic output voltage (RDY)	V_{RDY}	-0.3	6.5	V	-
Opendrain Logic output current (\overline{FLT})	$I_{FLT\#}$	-	10	mA	-
Opendrain Logic output current (RDY)	I_{RDY}	-	10	mA	-
Pin DESAT voltage	V_{DESAT}	-0.3	$V_{VCC2} + 0.3$	V	1)
Pin CLAMP voltage	V_{CLAMP}	-0.3	$V_{VCC2} + 0.3^{2)}$	V	3)
Junction temperature	T_J	-40	150	$^{\circ}C$	-
Storage temperature	T_S	-55	150	$^{\circ}C$	-
Power dissipation, per input part	$P_{D, IN}$	-	100	mW	4) @ $T_A = 25^{\circ}C$
Power dissipation, per output part	$P_{D, OUT}$	-	700	mW	4) @ $T_A = 25^{\circ}C$
Thermal resistance (Input part)	$R_{THJA, IN}$	-	139	K/W	4) @ $T_A = 25^{\circ}C$
Thermal resistance (Output chip active)	$R_{THJA, OUT}$	-	117	K/W	4) @ $T_A = 25^{\circ}C$
ESD Capability	V_{ESD}	-	1	kV	Human Body Model ⁵⁾

1) With respect to GND2.

2) May be exceeded during short circuit clamping.

Electrical Parameters

- 3) With respect to VEE2.
- 4) Output IC power dissipation is derated linearly at 8.5 mW/°C above 68°C. Input IC power dissipation does not require derating. See [Figure 10](#) for reference layouts for these thermal data. Thermal performance may change significantly with layout and heat dissipation of components in close proximity.
- 5) According to EIA/JESD22-A114-B (discharging a 100 pF capacitor through a 1.5 kΩ series resistor).

5.2 Operating Parameters

Note: Within the operating range the IC operates as described in the functional description. Unless otherwise noted all parameters refer to GND1.

Table 3 Operating Parameters

Parameter	Symbol	Values		Unit	Note
		Min.	Max.		
Positive power supply output side	V_{VCC2}	13	20	V	1)
Negative power supply output side	V_{VEE2}	-12	0	V	1)
Maximum power supply voltage output side ($V_{VCC2} - V_{VEE2}$)	V_{max2}	-	28	V	-
Positive power supply input side	V_{VCC1}	4.5	5.5	V	-
Logic input voltages (IN+, IN-, RST)	$V_{LogicIN}$	-0.3	5.5	V	-
Pin CLAMP voltage	V_{CLAMP}	$V_{VEE2} - 0.3$	$V_{VCC2}^{2)}$	V	-
Pin DESAT voltage	V_{DESAT}	-0.3	V_{VCC2}	V	1)
Pin TLSET voltage	V_{TLSET}	-0.3	V_{VCC2}	V	1)
Ambient temperature	T_A	-40	125	°C	-
Common mode transient immunity ³⁾	$ dV_{ISO}/dt $	-	50	kV/μs	@ 500 V

1) With respect to GND2.

2) May be exceeded during short circuit clamping.

3) The parameter is not subject to production test - verified by design/characterization

5.3 Recommended Operating Parameters

Note: Unless otherwise noted all parameters refer to GND1.

Table 4 Recommended Operating Parameters

Parameter	Symbol	Value	Unit	Note
Positive power supply output side	V_{VCC2}	15	V	1)
Negative power supply output side	V_{VEE2}	-8	V	1)
Positive power supply input side	V_{VCC1}	5	V	-

1) With respect to GND2.

Electrical Parameters

5.4 Electrical Characteristics

Note: The electrical characteristics include the spread of values in supply voltages, load and junction temperatures given below. Typical values represent the median values at $T_A = 25^\circ\text{C}$. Unless otherwise noted all voltages are given with respect to their respective GND (GND1 for pins 9 to 16, GND2 for pins 1 to 8).

5.4.1 Voltage Supply

Table 5 Voltage Supply

Parameter	Symbol	Values			Unit	Note
		Min.	Typ.	Max.		
UVLO Threshold Input Chip	V_{UVLOH1}	–	4.1	4.3	V	–
	V_{UVLOL1}	3.5	3.8	–	V	–
UVLO Hysteresis Input Chip ($V_{UVLOH1} - V_{UVLOL1}$)	V_{HYS1}	0.15	–	–	V	–
UVLO Threshold Output Chip	V_{UVLOH2}	–	12.0	12.6	V	–
	V_{UVLOL2}	10.4	11.0	–	V	–
UVLO Hysteresis Output Chip ($V_{UVLOH1} - V_{UVLOL1}$)	V_{HYS2}	0.7	0.9	–	V	–
Quiescent Current Input Chip	I_{Q1}	–	7	9	mA	$V_{VCC1} = 5\text{ V}$ IN+ = High, IN- = Low =>OUT = High, RDY = High, /FLT = High
Quiescent Current Output Chip	I_{Q2}	–	4	6	mA	$V_{VCC2} = 15\text{ V}$ $V_{VEE2} = -8\text{ V}$ IN+ = High, IN- = Low =>OUT = High, RDY = High, /FLT = High

Electrical Parameters

5.4.2 Logic Input and Output

Table 6 Logic Input and Output

Parameter	Symbol	Values			Unit	Note
		Min.	Typ.	Max.		
IN+,IN-, $\overline{\text{RST}}$ Low Input Voltage	$V_{\text{IN+L}}$, $V_{\text{IN-L}}$, $V_{\text{RSTL\#}}$	-	-	1.5	V	-
IN+,IN-, $\overline{\text{RST}}$ High Input Voltage	$V_{\text{IN+H}}$, $V_{\text{IN-H}}$, $V_{\text{RSTH\#}}$	3.5	-	-	V	-
IN-, $\overline{\text{RST}}$ Input Current	$I_{\text{IN-}}$, $I_{\text{RST\#}}$	-400	-100	-	μA	$V_{\text{IN-}} = \text{GND1}$ $V_{\text{RST\#}} = \text{GND1}$
IN+ Input Current	$I_{\text{IN+}}$	-	100	400	μA	$V_{\text{IN+}} = \text{VCC1}$
RDY, $\overline{\text{FLT}}$ Pull Up Current	I_{PRDY} , $I_{\text{PFLT\#}}$	-400	-100	-	μA	$V_{\text{RDY}} = \text{GND1}$ $V_{\text{FLT\#}} = \text{GND1}$
Input Pulse Suppression IN+, IN-	$T_{\text{MININ+}}$, $T_{\text{MININ-}}$	30	40	-	ns	-
Input Pulse Suppression $\overline{\text{RST}}$ for ENABLE/SHUTDOWN	T_{MINRST}	30	40	-	ns	-
Pulse Width $\overline{\text{RST}}$ for Resetting $\overline{\text{FLT}}$	T_{RST}	800	-	-	ns	-
$\overline{\text{FLT}}$ Low Voltage	V_{FLTL}	-	-	300	mV	$I_{\text{SINK(FLT\#)}} = 5 \text{ mA}$
RDY Low Voltage	V_{RDYL}	-	-	300	mV	$I_{\text{SINK(RDY)}} = 5 \text{ mA}$

Electrical Parameters

5.4.3 Gate Driver

Table 7 Gate Driver

Parameter	Symbol	Values			Unit	Note
		Min.	Typ.	Max.		
High Level Output Voltage	V_{OUTH1}	$V_{\text{CC2}} - 1.2$	$V_{\text{CC2}} - 0.8$	–	V	$I_{\text{OUTH}} = -20 \text{ mA}$
	V_{OUTH2}	$V_{\text{CC2}} - 2.5$	$V_{\text{CC2}} - 2.0$	–	V	$I_{\text{OUTH}} = -200 \text{ mA}$
	V_{OUTH3}	$V_{\text{CC2}} - 9$	$V_{\text{CC2}} - 5$	–	V	$I_{\text{OUTH}} = -1 \text{ A}$
	V_{OUTH4}		$V_{\text{CC2}} - 10$	–	V	$I_{\text{OUTH}} = -2 \text{ A}$
High Level Output Peak Current	I_{OUTH}	-1.5	-2.0	–	A	IN+ = High, IN- = Low; OUT = High
Low Level Output Voltage	V_{OUTL1}	–	$V_{\text{VEE2}} + 0.04$	$V_{\text{VEE2}} + 0.09$	V	$I_{\text{OUTL}} = 20 \text{ mA}$
	V_{OUTL2}	–	$V_{\text{VEE2}} + 0.3$	$V_{\text{VEE2}} + 0.85$	V	$I_{\text{OUTL}} = 200 \text{ mA}$
	V_{OUTL3}	–	$V_{\text{VEE2}} + 2.1$	$V_{\text{VEE2}} + 5$	V	$I_{\text{OUTL}} = 1 \text{ A}$
	V_{OUTL4}	–	$V_{\text{VEE2}} + 7$	–	V	$I_{\text{OUTL}} = 2 \text{ A}$
Low Level Output Peak Current	I_{OUTL}	1.5	2.0	–	A	IN+ = Low, IN- = Low; OUT = Low, $V_{\text{VCC2}} = 15 \text{ V}$, $V_{\text{VEE2}} = -8 \text{ V}$

5.4.4 Active Miller Clamp

Table 8 Active Miller Clamp

Parameter	Symbol	Values			Unit	Note
		Min.	Typ.	Max.		
Low Level Clamp Voltage	V_{CLAMPL1}	–	$V_{\text{VEE2}} + 0.03$	$V_{\text{VEE2}} + 0.08$	V	$I_{\text{OUTL}} = 20 \text{ mA}$
	V_{CLAMPL2}	–	$V_{\text{VEE2}} + 0.3$	$V_{\text{VEE2}} + 0.8$	V	$I_{\text{OUTL}} = 200 \text{ mA}$
	V_{CLAMPL3}	–	$V_{\text{VEE2}} + 1.9$	$V_{\text{VEE2}} + 4.8$	V	$I_{\text{OUTL}} = 1 \text{ A}$
Low Level Clamp Current	I_{CLAMPL}	2	–	–	A	1)
Clamp Threshold Voltage	V_{CLAMP}	1.6	2.1	2.4	V	Related to VEE2

1) The parameter is not subject to production test - verified by design/characterization

Electrical Parameters

5.4.5 Short Circuit Clamping

Short circuit clamping characteristics are measured with $IN+ = \text{High}$, $IN- = \text{Low}$ and $OUT = \text{High}$.

Table 9 Short Circuit Clamping

Parameter	Symbol	Values			Unit	Note
		Min.	Typ.	Max.		
Clamping voltage (OUT) ($V_{OUT} - V_{VCC2}$)	V_{CLPout}	–	0.8	1.3	V	I_{pulse} test, $t_{CLPmax} = 10 \mu s$
Clamping voltage (CLAMP) ($V_{VCLAMP} - V_{VCC2}$)	$V_{CLPclamp}$	–	1.3	–	V	$I_{CLAMP} = 500 \text{ mA}$ (pulse test, $t_{CLPmax} = 10 \mu s$)
Clamping voltage (CLAMP)	$V_{CLPclamp}$	–	0.7	1.1	V	$I_{CLAMP} = 20 \text{ mA}$

5.4.6 Dynamic Characteristics

Dynamic characteristics are measured with $V_{VCC1} = 5 \text{ V}$, $V_{VCC2} = 15 \text{ V}$ and $V_{VEE2} = -8 \text{ V}$.

Table 10 Dynamic Characteristics

Parameter	Symbol	Values			Unit	Note
		Min.	Typ.	Max.		
Input $IN+$, $IN-$ to output propagation delay ON	T_{PDON}	145	170	195	ns	$C_{LOAD} = 100 \text{ pF}$ $V_{IN+} = 50\%$, $V_{OUT} = 50\% @ 25^\circ\text{C}$
Input $IN+$, $IN-$ to output propagation delay OFF	T_{PDOFF}	145	165	190	ns	
Input $IN+$, $IN-$ to output propagation delay distortion ($T_{PDOFF} - T_{PDON}$)	T_{PDISTO}	-35	-5	25	ns	
Input $IN+$, $IN-$ to output propagation delay ON variation due to temp	T_{PDONt}	160	190	220	ns	$C_{LOAD} = 100 \text{ pF}$ $V_{IN+} = 50\%$, $V_{OUT} = 50\% @ 125^\circ\text{C}$
Input $IN+$, $IN-$ to output propagation delay OFF variation due to temp	T_{PDOFFt}	165	195	225	ns	
Input $IN+$, $IN-$ to output propagation delay distortion ($T_{PDOFF} - T_{PDON}$)	$T_{PDISTOt}$	-25	5	35	ns	

Electrical Parameters

Table 10 Dynamic Characteristics (cont'd)

Parameter	Symbol	Values			Unit	Note
		Min.	Typ.	Max.		
Input IN+, IN- to output propagation delay ON variation due to temp	T_{PDONt}	135	165	195	ns	$C_{LOAD} = 100 \text{ pF}$ $V_{IN+} = 50\%$, $V_{OUT} = 50\% @ -40^{\circ}\text{C}$
Input IN+, IN- to output propagation delay OFF variation due to temp	T_{PDOFFt}	125	155	185	ns	
Input IN+, IN- to output propagation delay distortion ($T_{PDOFF} - T_{PDON}$)	$T_{PDISTOt}$	-40	-10	20	ns	
Rise Time	T_{RISE}	10	30	60	ns	$C_{LOAD} = 1 \text{ nF}$ $V_L 10\%, V_H 90\%$
		200	400	800	ns	$C_{LOAD} = 34 \text{ nF}$ $V_L 10\%, V_H 90\%$
Fall Time	T_{FALL}	10	50	90	ns	$C_{LOAD} = 1 \text{ nF}$ $V_L 10\%, V_H 90\%$
		200	350	600	ns	$C_{LOAD} = 34 \text{ nF}$ $V_L 10\%, V_H 90\%$

5.4.7 Desaturation Protection

Table 11 Desaturation Protection

Parameter	Symbol	Values			Unit	Note
		Min.	Typ.	Max.		
Blanking Capacitor Charge Current	I_{DESATC}	450	500	550	μA	$V_{VCC2} = 15 \text{ V}$, $V_{VEE2} = -8 \text{ V}$ $V_{DESAT} = 2 \text{ V}$
Blanking Capacitor Discharge Current	I_{DESATD}	9	14	-	mA	$V_{VCC2} = 15 \text{ V}$, $V_{VEE2} = -8 \text{ V}$ $V_{DESAT} = 6 \text{ V}$
Desaturation Reference Level	V_{DESAT}	8.3	9	9.5	V	$V_{VCC2} = 15 \text{ V}$
Desaturation Filter Time	$T_{DESATfilter}$	-	250	-	ns	$V_{VCC2} = 15 \text{ V}$, $V_{VEE2} = -8 \text{ V}$ $V_{DESAT} = 9 \text{ V}$
Desaturation Sense to OUT Low Delay	$T_{DESATOUT}$	-	350	430	ns	$V_{OUT} = 90\%$ $C_{LOAD} = 1 \text{ nF}$
Desaturation Sense to FLT Low Delay	$T_{DESATFLT}$	-	-	2.25	μs	$V_{FLT\#} = 10\%$; $I_{FLT\#} = 5 \text{ mA}$

Electrical Parameters

Table 11 Desaturation Protection (cont'd)

Parameter	Symbol	Values			Unit	Note
		Min.	Typ.	Max.		
Desaturation Low Voltage	V_{DESATL}	0.4	0.6	0.95	V	IN+ = Low, IN- = Low, OUT = Low
Leading edge blanking	$T_{DESATleb}$	–	400	–	ns	Not subject of production test

Electrical Parameters

5.4.8 Active Shut Down

Table 12 Active Shut Down

Parameter	Symbol	Values			Unit	Note
		Min.	Typ.	Max.		
Active Shut Down Voltage	$V_{ACTSD}^{1)}$	-	-	2.0	V	$I_{OUT} = -200 \text{ mA}$, V_{CC2} open

1) With reference to VEE2

Insulation Characteristics

6 Insulation Characteristics

Insulation characteristics are guaranteed only within the safety maximum ratings which must be ensured by protective circuits in application. Surface mount classification is class A in accordance with CECC00802.

This coupler is suitable for “basic insulation” only within the safety ratings. Compliance with the safety ratings shall be ensured by means of suitable protective circuits.

6.1 Certified according to DIN EN 60747-5-2 (VDE 0884 Teil 2): 2003-01. Basic Insulation

Table 13 According to DIN EN 60747-5-2

Description	Symbol	Characteristic	Unit
Installation classification per EN 60664-1, Table 1 for rated mains voltage $\leq 150 V_{RMS}$ for rated mains voltage $\leq 300 V_{RMS}$ for rated mains voltage $\leq 600 V_{RMS}$		I-IV I-III I-II	–
Climatic Classification		40/125/21	–
Pollution Degree (EN 60664-1)		2	–
Minimum External Clearance	CLR	8	mm
Minimum External Creepage	CPG	8	mm
Minimum Comparative Tracking Index	CTI	175	–
Maximum Repetitive Insulation Voltage	V_{IORM}	1420	V_{PEAK}
Highest Allowable Overvoltage	V_{IOTM}	6000	V_{PEAK}
Maximum Surge Insulation Voltage	V_{IOSM}	6000	V

6.2 Recognized under UL 1577

Table 14 Recognized under UL 1577

Description	Symbol	Characteristic	Unit
Insulation Withstand Voltage / 1 min	V_{ISO}	3750	V_{rms}
Insulation Test Voltage / 1 s	V_{ISO}	4500	V_{rms}

6.3 Reliability

For Qualification Report please contact your local Infineon Technologies office.

7 Timing Diagramms

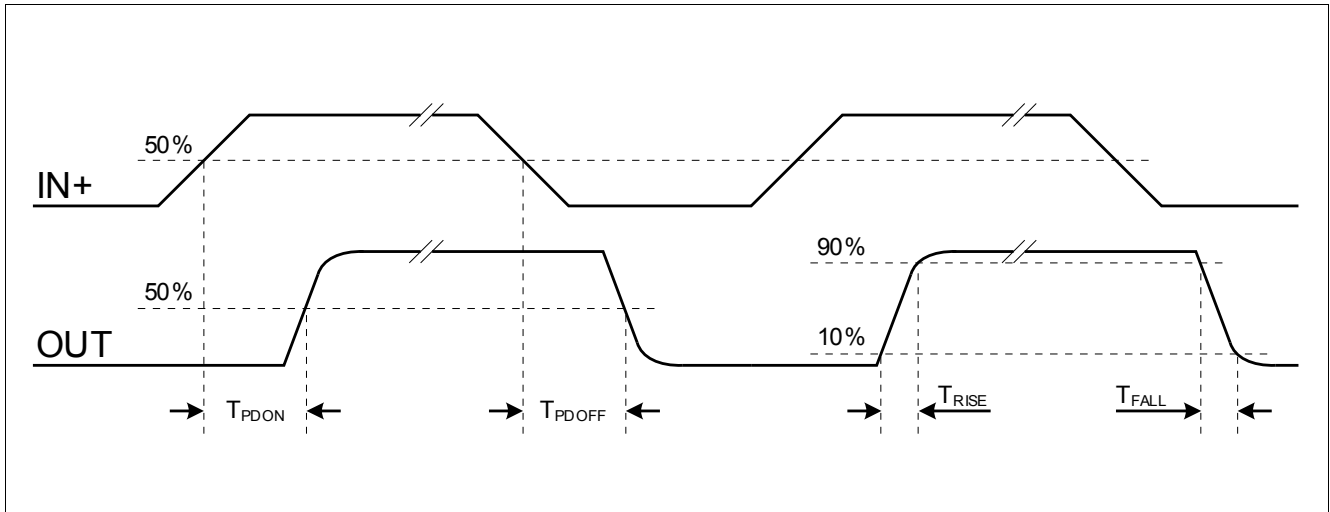

Figure 5 Propagation Delay, Rise and Fall Time

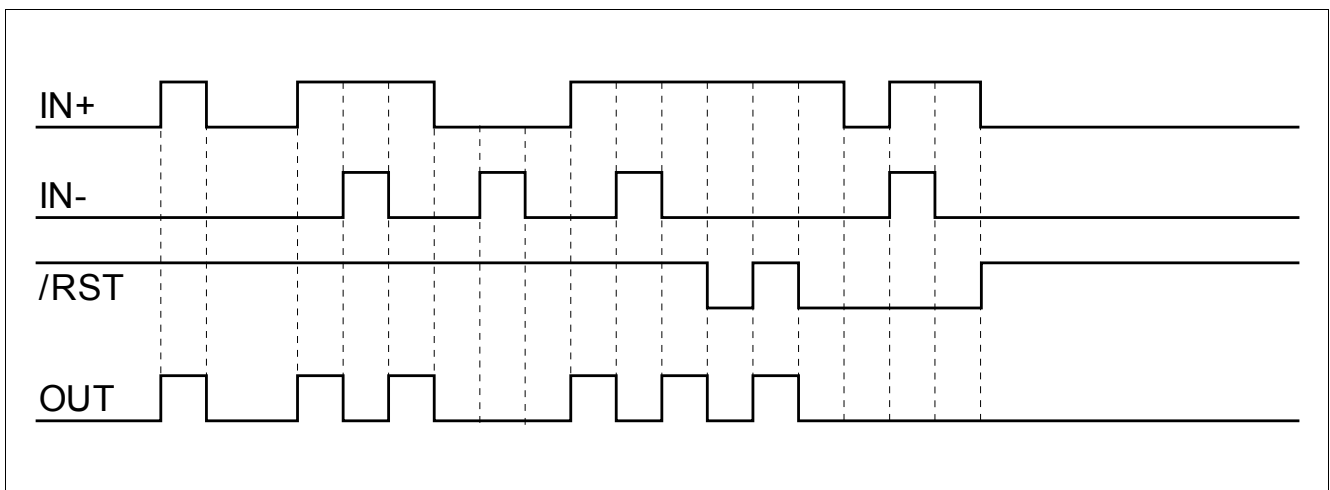

Figure 6 Typical Switching Behavior

Timing Diagramms

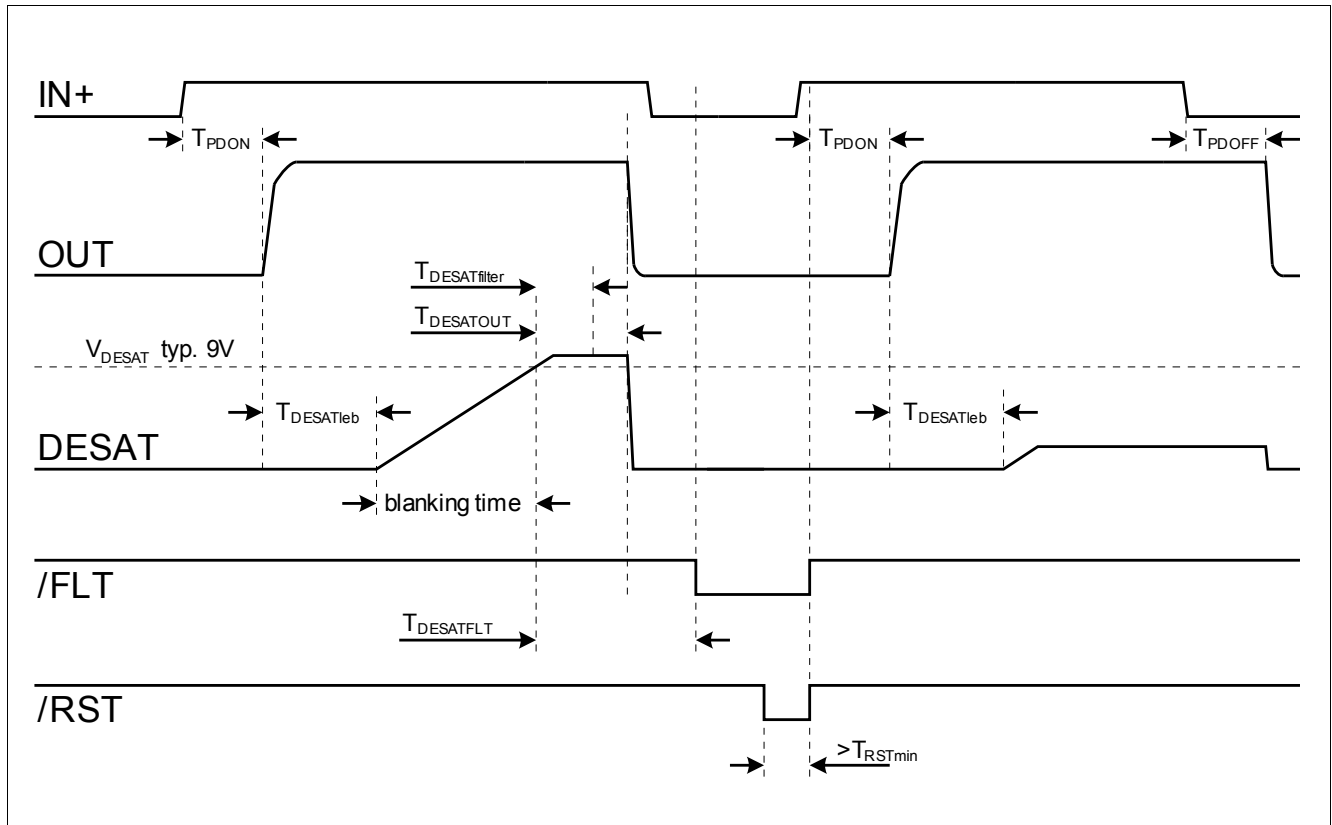

Figure 7 DESAT Switch-Off Behavior

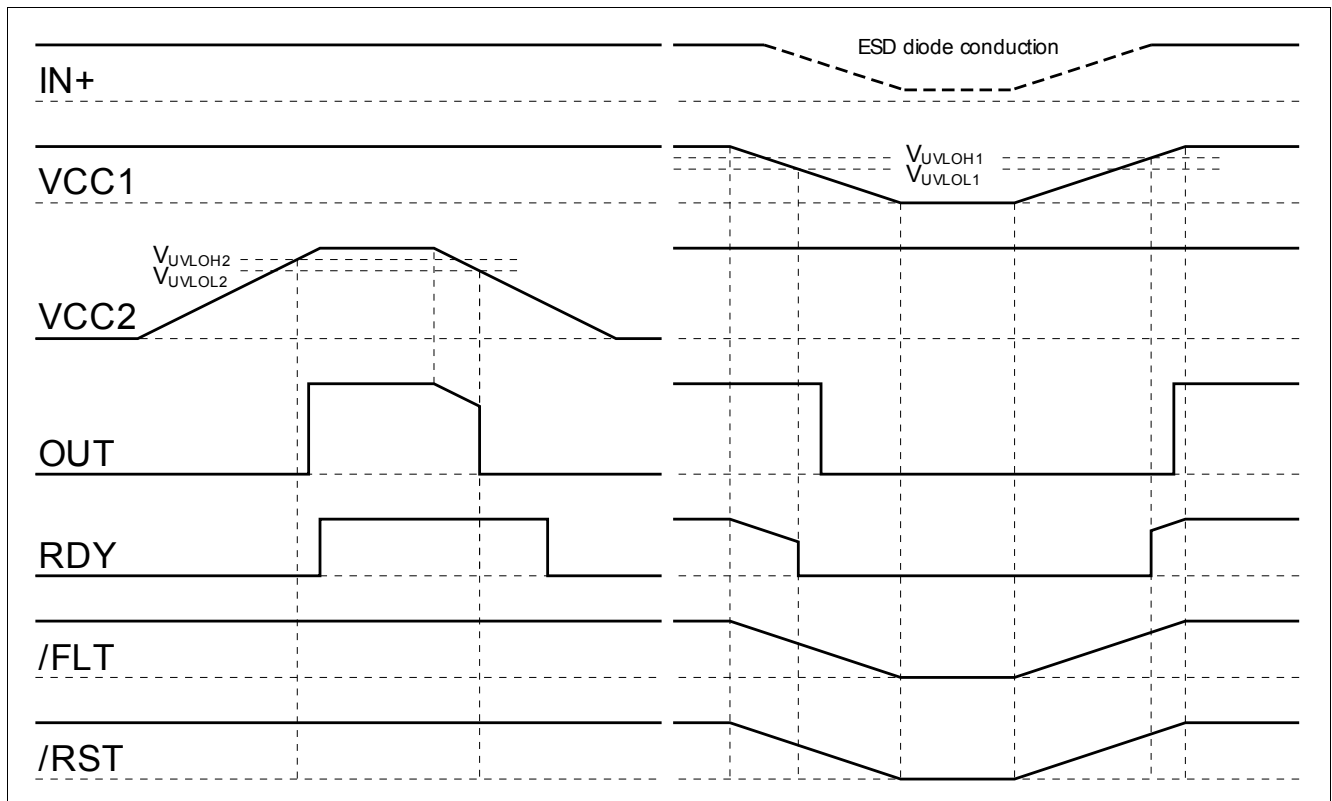

Figure 8 UVLO Behavior

8 Package Outlines

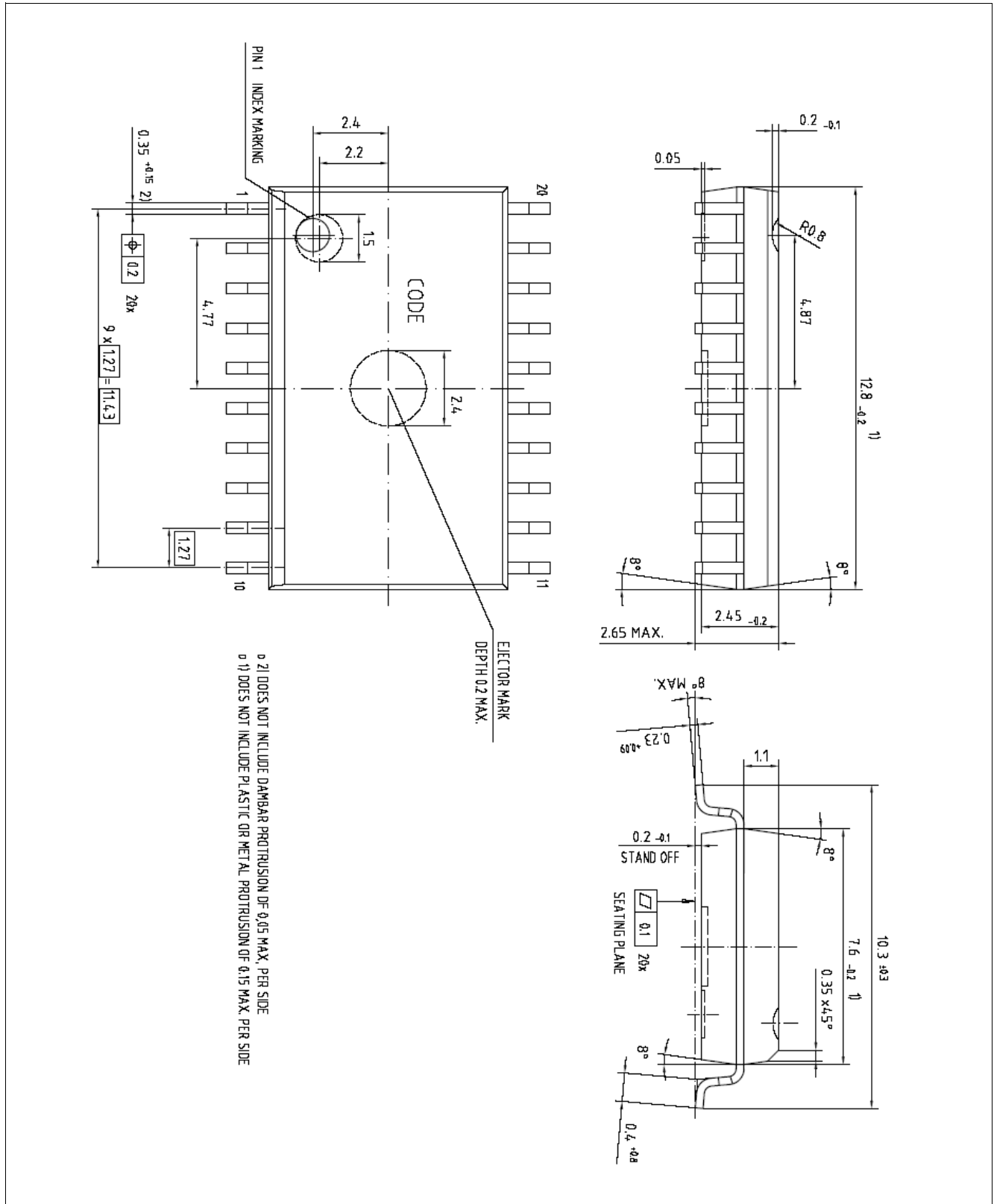

Figure 9 PG-DSO-20 (Plastic (Green) Dual Small Outline Package)

9 Application Notes

9.1 Reference Layout for Thermal Data

The PCB layout shown in [Figure 10](#) represents the reference layout used for the thermal characterisation. Pins 11, 12, 19 and 20 (GND1) and pins 1, 2, 9 and 10 (VEE2) require ground plane connections for achieving maximum power dissipation. The 1ED020I12FA2 is conceived to dissipate most of the heat generated through this pins.

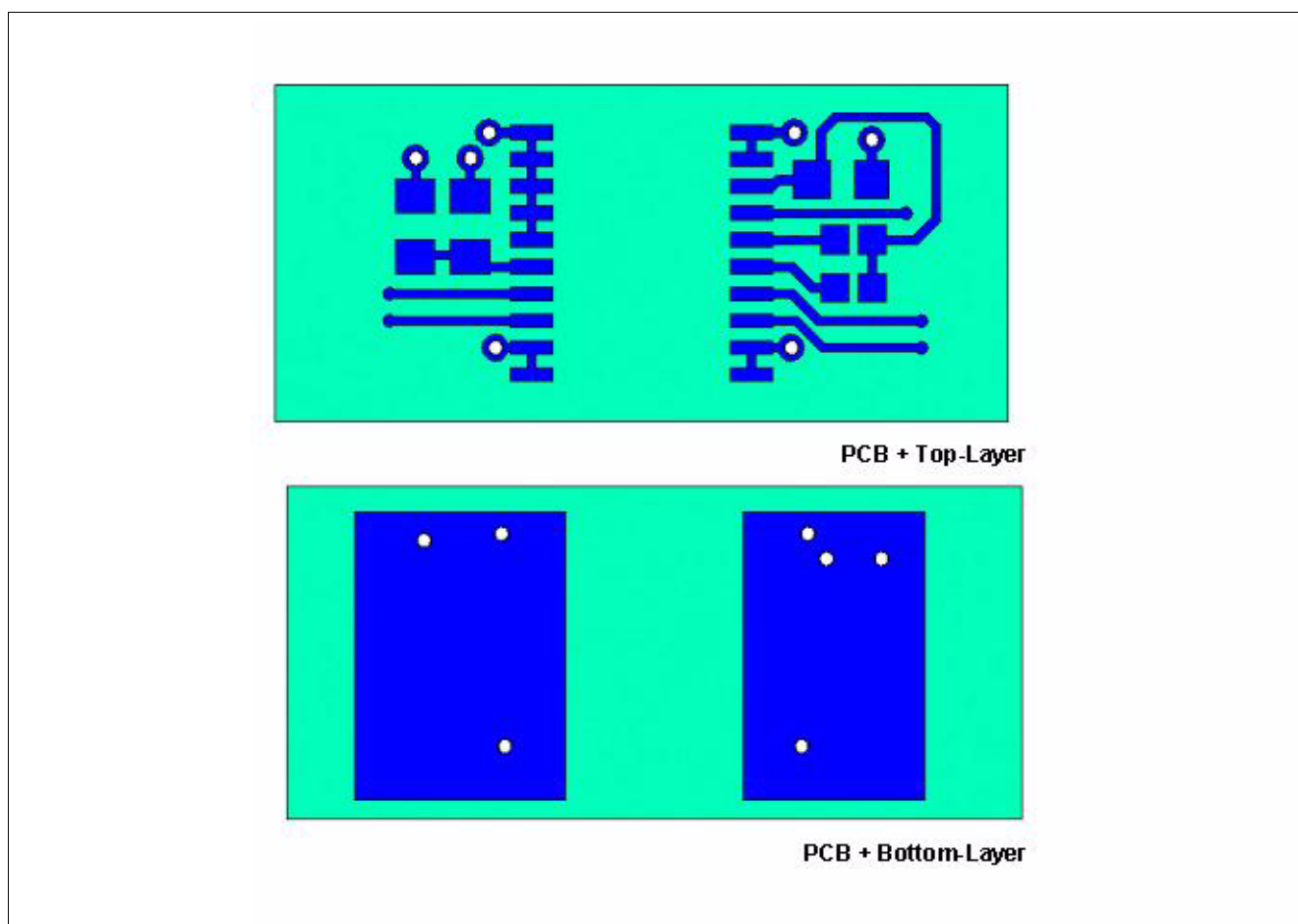

Figure 10 Reference Layout for Thermal Data (Copper thickness 102 μm)

9.2 Printed Circuit Board Guidelines

Following factors should be taken into account for an optimum PCB layout.

- Sufficient spacing should be kept between high voltage isolated side and low voltage side circuits.
- The same minimum distance between two adjacent high-side isolated parts of the PCB should be maintained to increase the effective isolation and reduce parasitic coupling.
- In order to ensure low supply ripple and clean switching signals, bypass capacitor trace lengths should be kept as short as possible.
- Lowest trace length for VEE2 to GND2 decoupling could be achieved with capacitor closed to pins 2 and 4.

Revision History

Page or Item	Subjects (major changes since previous revision)
Rev. 3.0, 2016-04-04	
All	Update latest template
Figure 1	Blockdiagram update
Table 2, Table 3, Table 4, Table 5, Table 6, Table 7, Table 8, Table 9, Table 10, Table 11, Table 12	Removed Test Condition in table header
Table 5	Changed V_{UVLOH1} into V_{UVL0L1}
Table 2	Symbol changed from Vmax2 to Vcc2 in Gate driver output

Trademarks of Infineon Technologies AG

μ HVIC™, μ IPM™, μ PFC™, AU-ConvertIR™, AURIX™, C166™, CanPAK™, CIPOS™, CIPURSE™, CoolDP™, CoolGaN™, COOLiR™, CoolMOS™, CoolSET™, CoolSiC™, DAVE™, DI-POL™, DirectFET™, DrBlade™, EasyPIM™, EconoBRIDGE™, EconoDUAL™, EconoPACK™, EconoPIM™, EiceDRIVER™, eupec™, FCOS™, GaNpowIR™, HEXFET™, HITFET™, HybridPACK™, iMOTION™, IRAM™, ISOFACE™, IsoPACK™, LEDriviR™, LITIX™, MIPAQ™, ModSTACK™, my-d™, NovalithIC™, OPTIGA™, OptiMOS™, ORIGA™, PowIRaudio™, PowIRstage™, PrimePACK™, PrimeSTACK™, PROFET™, PRO-SIL™, RASIC™, REAL3™, SmartLEWIS™, SOLID FLASH™, SPOC™, StrongIRFET™, SupIRBuck™, TEMPFET™, TRENCHSTOP™, TriCore™, UHVIC™, XHP™, XMC™.

Trademarks updated November 2015

Other Trademarks

All referenced product or service names and trademarks are the property of their respective owners.

Edition 2016-04-04

Published by

Infineon Technologies AG

81726 Munich, Germany

© 2016 Infineon Technologies AG.

All Rights Reserved.

Do you have a question about any aspect of this document?

Email: erratum@infineon.com

IMPORTANT NOTICE

The information given in this document shall in no event be regarded as a guarantee of conditions or characteristics ("Beschaffheitsgarantie").

With respect to any examples, hints or any typical values stated herein and/or any information regarding the application of the product, Infineon Technologies hereby disclaims any and all warranties and liabilities of any kind, including without limitation warranties of non-infringement of intellectual property rights of any third party.

In addition, any information given in this document is subject to customer's compliance with its obligations stated in this document and any applicable legal requirements, norms and standards concerning customer's products and any use of the product of Infineon Technologies in customer's applications.

The data contained in this document is exclusively intended for technically trained staff. It is the responsibility of customer's technical departments to evaluate the suitability of the product for the intended application and the completeness of the product information given in this document with respect to such application.

For further information on technology, delivery terms and conditions and prices, please contact the nearest Infineon Technologies Office (www.infineon.com).

WARNINGS

Due to technical requirements products may contain dangerous substances. For information on the types in question please contact your nearest Infineon Technologies office.

Except as otherwise explicitly approved by Infineon Technologies in a written document signed by authorized representatives of Infineon Technologies, Infineon Technologies' products may not be used in any applications where a failure of the product or any consequences of the use thereof can reasonably be expected to result in personal injury.

Looking for pricing, stock, or lifecycle information?

Click below to explore more details on WIN SOURCE:

-  [View 1ED020I12FA on WIN SOURCE](#)
-  [Infineon Technologies Information](#)

Optimize Your Supply Chain with WIN SOURCE Solutions

-  Global Sourcing Solution
-  Obsolete Management
-  Cost Control Management
-  Shortage Management
-  Alternative Solution
-  Excess Inventory Management