

Power Inductors / Wire Wound type

Series: **S**
 Type: **ELL5PS**



■ Features

- Magnetic shielded structure
- Low DC resistance and large current capability
- RoHS compliant

■ Recommended Applications

- DC-DC converter circuitry for computer peripherals and cellular phones.
- Chopper circuit decoupling chokes for DC-DC converter circuitry

■ Standard Packing Quantity

- 2000 pcs./Reel

■ Soldering Conditions and Safety Precautions

Please see Data Files

■ Explanation of Part Numbers

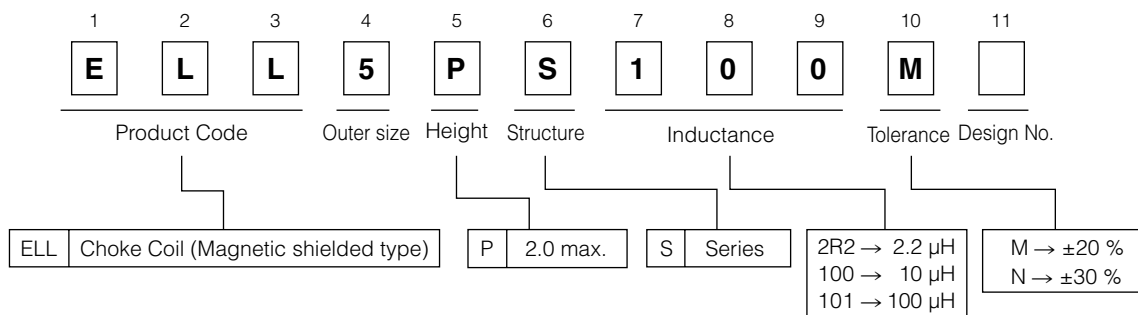

■ Dimensions in mm (not to scale)

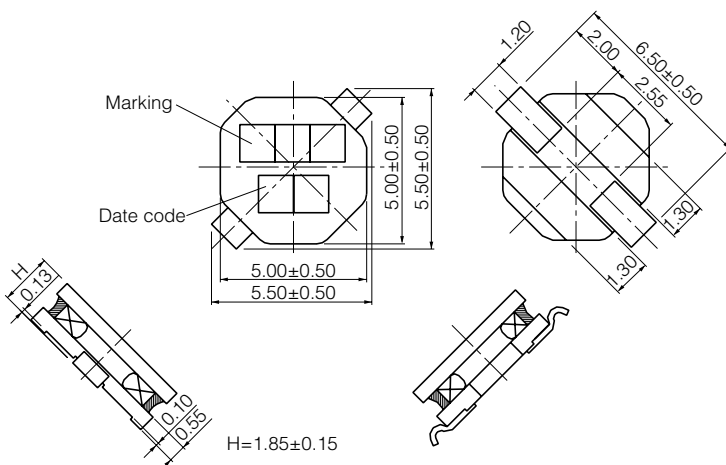

■ Recommended Land Pattern in mm (not to scale)

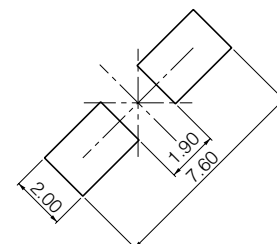

Standard Parts

Part Number	Inductance (100 kHz)		RDC (at 20 °C)		Saturation Rated Current* ¹ (mA max.)	Temperature Rise Current* ² (mA max.)	Marking
	(μH)	Tol.	(mΩ)	Tol.			
ELL5PS1R2N	1.2	±30 %	22	±20 %	2500	2500	1R2
ELL5PS1R5N	1.5		28		2400	2400	1R5
ELL5PS2R2N	2.2		34		2100	2100	2R2
ELL5PS2R7N	2.7		40		2000	2050	2R7
ELL5PS3R3N	3.3		46		1900	2000	3R3
ELL5PS4R7N	4.7		61		1500	1600	4R7
ELL5PS6R8N	6.8		96		1280	1280	6R8
ELL5PS100M	10.0	±20 %	120	1000	1100	100	
ELL5PS150M	15.0		170	790	1000	150	
ELL5PS220M	22.0		290	650	750	220	
ELL5PS330M	33.0		470	490	490	330	
ELL5PS470M	47.0		620	450	550	470	
ELL5PS560M	56.0		680	430	500	560	
ELL5PS680M	68.0		750	380	480	680	
ELL5PS820M	82.0		1160	340	360	820	
ELL5PS101M	100.0		1320	300	340	101	
ELL5PS221M	220.0		3450	210	210	221	
ELL5PS331M	330.0		4700	180	180	331	
ELL5PS471M	470.0		8100	160	140	471	
ELL5PS561M	560.0		9500	150	125	561	

*1 Saturation Rated Current : This DC current which causes a 30 % inductance reduction from its nominal value.

*2 Temperature Rise Current : This indicates the value of current when temperature rise dt/t= 40 °C (at 20 °C).

Embossed Carrier Tape Dimensions in mm (not to scale)

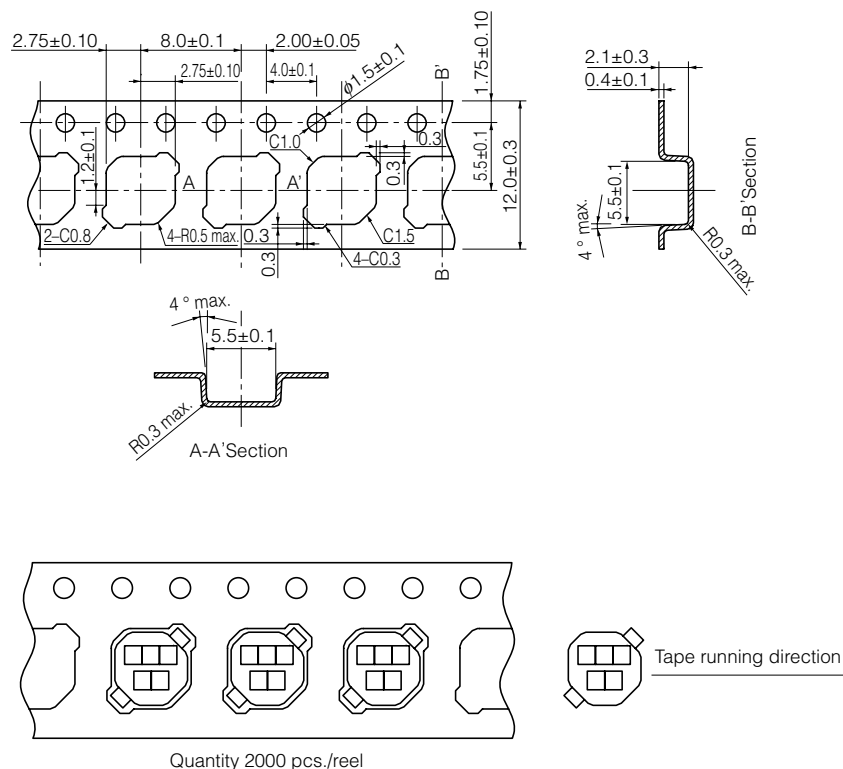

Design and specifications are each subject to change without notice. Ask factory for the current technical specifications before purchase and/or use. Should a safety concern arise regarding this product, please be sure to contact us immediately.

Looking for pricing, stock, or lifecycle information?

Click below to explore more details on WIN SOURCE:

- ⊖ [View ELL-5PS470M on WIN SOURCE](#)
- ⊖ [Panasonic Information](#)

Optimize Your Supply Chain with WIN SOURCE Solutions

- ✓ Global Sourcing Solution
- ✓ Obsolete Management
- ✓ Cost Control Management
- ✓ Shortage Management
- ✓ Alternative Solution
- ✓ Excess Inventory Management