



THE DATASHEET OF ELJ-NK22NAF



Chip Inductors

Series: **Chip**
 Type: **RG, RF, RE, NJ, ND, NC, NA, NK, FJ, FC, FA, FB, SA, PF, PE, PC, PA, PB, EA, QF, QE**

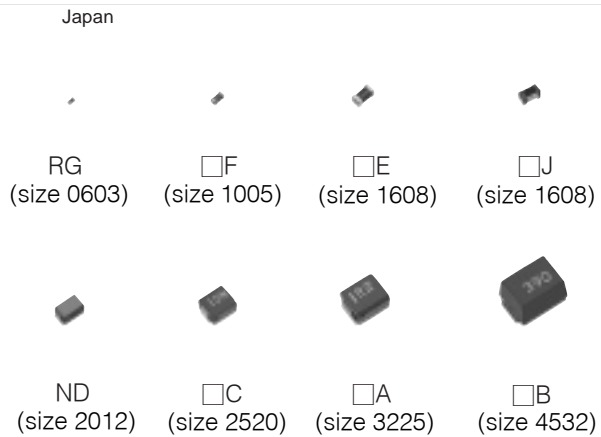

Non-wound (laser-cut) and wire wound types of chip inductors designed for automatic and high density mounting

■ Features

- High Q
- Good mounting reliability
- Wide range of inductance values (1.0 nH to 1000 μ H)
- Stable L value in any mounting direction (Non wound type)

■ Recommended Applications

- Cordless telephones, Wireless Communication equipment (WLAN, Bluetooth), PDA, Camcorders, Digital Still Cameras, TV, VCR, PC Peripherals, Hybrid modules

■ Explanation of Part Numbers

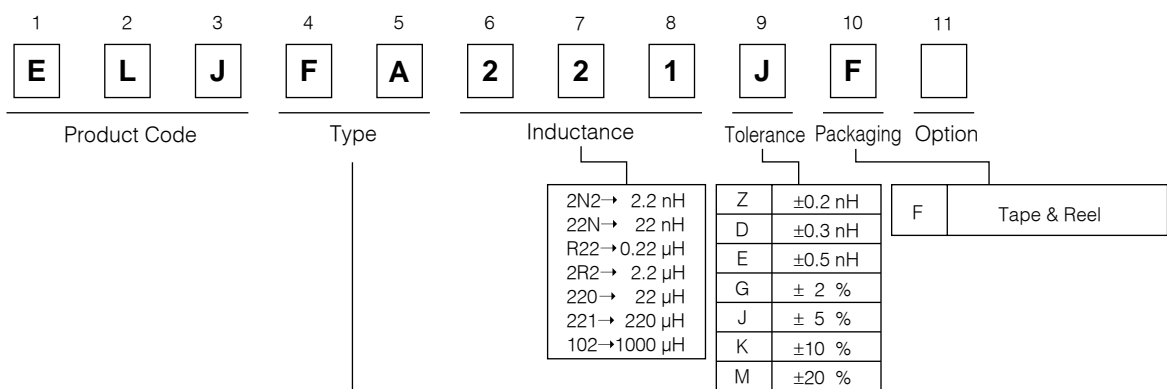

Item	Non wound type			Wire wound type					
	Styles	Styles	Styles	Styles	Styles	Styles	Styles	Styles	Styles
Types	G 0603 (0201)	F 1005 (0402)	E 1608 (0603)	K 1005 (0402)	J 1608 (0603)	D 2012 (0805)	C 2520 (1008)	A 3225 (1210)	B 4532 (1812)
Non Magnetic Core	RG	RF	RE	NK	–	ND	NC	NA	–
Higher Q Type	–	QF	QE	–	NJ	–	–	–	–
Regular	–	–	–	–	FJ	–	FC	FA	FB
Shield	–	–	–	–	–	–	–	SA	–
High Power	–	PF	PE	–	–	–	PC	PA	PB
Low DC resistance	–	–	–	–	–	–	–	EA	–

Size unit: mm (inch)

Inductance, Size Guide

	Type NAME mm (EIA)	L VALUE							Features		
		0.001	0.01	0.1	1.0	10	100	(H) 1000			
Non Magnetic Core	0603 (0201) RG NEW	D J							<div style="border: 1px solid black; padding: 5px; width: fit-content;"> Tolerance Z : ± 0.2 nH D : ± 0.3 nH E : ± 0.5 nH G : ± 2 % J : ± 5 % K : ± 10 % M : ± 20 % </div>		
	1005 (0402) RF	D J									
	1608 (0603) RE	D J									
	1608 (0603) NJ NEW	E,Z J,G									
	2012 (0805) ND	K J,K									
	2520 (1008) NC	K J,K									
	3225 (1210) NA	M K J									
Regular	1608 (0603) FJ NEW			J						<ul style="list-style-type: none"> ● Suitable for various applications 	
	2520 (1008) FC			K,M J,K							
	3225 (1210) FA			K,M J,K							
	3225 (1210) SA Mag. shield				K						
	4532 (1812) FB			M K,M J,K							
High Power	1005 (0402) PF NEW	D,J							<ul style="list-style-type: none"> ● Large DC current ● Suitable for power line as choke coil 		
	1608 (0603) PE	K									
	2520 (1008) PC			M K							
	3225 (1210) PA			M K							
	4532 (1812) PB				K						
Low DC resistance	3225 (1210) EA			M K						<ul style="list-style-type: none"> ● Low DC resistance 	

1. Non Magnetic Core Types RG, RF, RE, NK, NJ, ND, NC, NA

■ Type 0603(0201)RG

● Dimensions in mm (not to scale)

● Recommended Land Pattern in mm (not to scale)

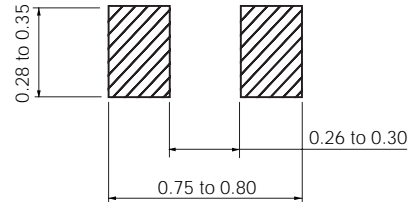
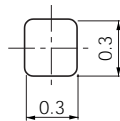
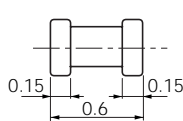

■ Standard Packing Quantity

● 15000 pcs./Reel

■ Examples

Part No.	Inductance		Q min.	L, Q Test Freq. (MHz)	SRF *1 (MHz)min.	DCR *2 (Ω)max.	DC Current (mA)max.		
	(nH)	Tolerance							
ELJRG1N0D/ZF	1.0	±0.3 nH	4	100	20000	0.12	550		
ELJRG1N2D/ZF	1.2				20000	0.15	550		
ELJRG1N5D/ZF	1.5				20000	0.18	550		
ELJRG1N8D/ZF	1.8				20000	0.22	420		
ELJRG2N2D/ZF	2.2				13000	0.26	420		
ELJRG2N7D/ZF	2.7				13000	0.32	420		
ELJRG3N3D/ZF	3.3				±0.2 nH	4	10000	0.38	300
ELJRG3N9D/ZF	3.9						9600	0.48	300
ELJRG4N7D/ZF	4.7						8800	0.56	300
ELJRG5N6D/ZF	5.6						8300	0.70	230
ELJRG6N8J/ZF	6.8	7400	0.82	230					
ELJRG8N2J/ZF	8.2	7000	1.00	230					
ELJRG10NJ/GF	10.0	±5 %	3	6600			1.30	230	
ELJRG12NJ/GF	12.0			6100			1.60	190	
ELJRG15NJ/GF	15.0			5600	2.20	150			
ELJRG18NJ/GF	18.0			5400	2.80	130			
ELJRG22NJ/GF	22.0			4600	3.50	120			
ELJRG27NJ/GF	27.0			4700	4.00	110			
ELJRG33NJ/GF	33.0			4500	6.00	90			
ELJRG39NJ/GF	39.0			4000	8.00	80			
ELJRG47NJ/GF	47.0	±2 %	2	3400	10.00	70			

*1 : Self Resonant Frequency *2 : DC Resistance

■ Type 1005(0402)RF

● Dimensions in mm (not to scale)

● Recommended Land Pattern in mm (not to scale)

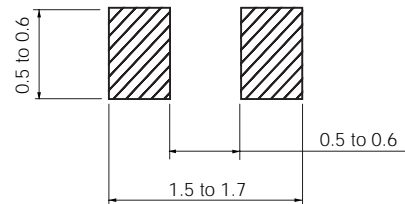
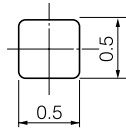
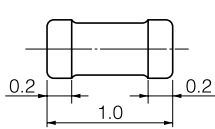

■ Standard Packing Quantity

● 10000 pcs./Reel

■ Examples

Part No.	Inductance		Q min.	L, Q Test Freq. (MHz)	SRF *1 (MHz)min.	DCR *2 (Ω)max.	DC Current (mA)max.
	(nH)	Tolerance					
ELJRF1N0D/ZF2	1.0	±0.3 nH	8	100	6000	0.05	400
ELJRF1N2D/ZF2	1.2				6000	0.06	400
ELJRF1N5D/ZF2	1.5				6000	0.07	400
ELJRF1N8D/ZF2	1.8				6000	0.08	400
ELJRF2N2D/ZF2	2.2				6000	0.09	400
ELJRF2N7D/ZF2	2.7				5500	0.10	400
ELJRF3N3D/ZF2	3.3				5500	0.12	400
ELJRF3N9D/ZF2	3.9				5200	0.15	360
ELJRF4N7D/ZF2	4.7				4800	0.17	360
ELJRF5N6D/ZF2	5.6				4600	0.19	340
ELJRF6N8J/ZF2	6.8	± 5 %	8	100	4000	0.30	320
ELJRF8N2J/ZF2	8.2				3500	0.35	320
ELJRF10NJ/GF2	10.0				2800	0.41	320
ELJRF12NJ/GF2	12.0				2800	0.45	320
ELJRF15NJ/GF2	15.0				2500	0.60	240
ELJRF18NJ/GF2	18.0				2200	0.70	240
ELJRF22NJ/GF2	22.0				2000	0.80	200
ELJRF27NJ/GF2	27.0				1800	1.20	200
ELJRF33NJ/GF2	33.0				1800	1.40	170
ELJRF39NJ/GF2	39.0				1800	1.70	150
ELJRF47NJ/GF2	47.0	1800	2.10	140			
ELJRF56NJ/GF2	56.0	1500	2.50	130			
ELJRF68NJ/GF2	68.0	1500	4.00	120			
ELJRF82NJ/GF2	82.0	1400	4.50	110			
ELJRFR10J/GF2	100.0	1200	5.50	90			
ELJRF3N6D/ZF2	3.6	±0.3 nH	8	100	5300	0.14	380
ELJRF4N3D/ZF2	4.3				5000	0.16	360
ELJRF5N1D/ZF2	5.1				4700	0.18	350
ELJRF6N2D/ZF2	6.2				4300	0.25	330
ELJRF7N5J/ZF2	7.5				3700	0.33	320
ELJRF9N1J/ZF2	9.1				3100	0.38	320
ELJRF11NJ/GF2	11.0				2800	0.43	320
ELJRF13NJ/GF2	13.0				2600	0.53	280
ELJRF16NJ/GF2	16.0				2300	0.65	240
ELJRF20NJ/GF2	20.0				2100	0.75	220
ELJRF24NJ/GF2	24.0	1900	1.00	200			
ELJRF30NJ/GF2	30.0	1800	1.30	190			
ELJRF36NJ/GF2	36.0	1800	1.60	160			
ELJRF43NJ/GF2	43.0	1800	1.90	150			

*1 : Self Resonant Frequency *2 : DC Resistance

■ Type 1608(0603)RE

● Dimensions in mm (not to scale)

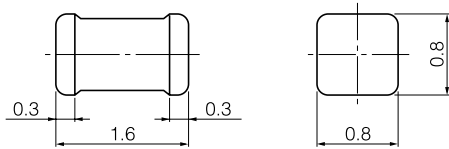

● Recommended Land Pattern in mm (not to scale)

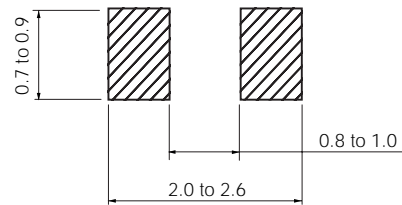

■ Standard Packing Quantity

● 3000 pcs./Reel

■ Examples

Part No.	Inductance		Q min.	L, Q Test Freq. (MHz)	SRF *1 (MHz)min.	DCR *2 (Ω)max.	DC Current (mA)max.		
	(nH)	Tolerance							
ELJRE1N0D/ZF2	1.0	±0.3 nH	7	100	6000	0.05	500		
ELJRE1N2D/ZF2	1.2				6000	0.06	500		
ELJRE1N5D/ZF2	1.5		8		6000	0.07	500		
ELJRE1N8D/ZF2	1.8				6000	0.08	500		
ELJRE2N2D/ZF2	2.2		±0.2 nH		9	6000	0.09	500	
ELJRE2N7D/ZF2	2.7					6000	0.10	500	
ELJRE3N3D/ZF2	3.3		±5 %		10	5500	0.12	500	
ELJRE3N9J/ZF2	3.9					5500	0.15	450	
ELJRE4N7J/ZF2	4.7				±2 %	11	4800	0.17	450
ELJRE5N6J/ZF2	5.6						4600	0.18	430
ELJRE6N8J/ZF2	6.8	±0.2 nH		12	3550	0.20	430		
ELJRE8N2J/ZF2	8.2				3500	0.28	400		
ELJRE10NJ/GF2	10.0	±5 %		5	2800	0.32	400		
ELJRE12NJ/GF2	12.0				2800	0.35	400		
ELJRE15NJ/GF2	15.0			±2 %	10	2500	0.41	350	
ELJRE18NJ/GF2	18.0					2300	0.45	350	
ELJRE22NJ/GF2	22.0		±0.2 nH	9	2000	0.50	300		
ELJRE27NJ/GF2	27.0				2000	0.55	300		
ELJRE33NJ/GF2	33.0		±5 %	4	1800	0.60	300		
ELJRE39NJ/GF2	39.0				1800	0.80	300		
ELJRE47NJ/GF2	47.0			±2 %	11	1800	0.95	250	
ELJRE56NJ/GF3	56.0					1800	1.20	250	
ELJRE68NJ/GF3	68.0	±0.2 nH		9	1500	1.30	250		
ELJRE82NJ/GF3	82.0				1500	1.50	250		
ELJRER10J/GF3	100.0	±5 %		5	1300	1.80	200		
ELJRER12J/GF3	120.0				1200	3.00	130		
ELJRER15J/GF3	150.0			±2 %	10	1100	4.50	100	
ELJRER18J/GF3	180.0					1000	6.50	80	
ELJRER22J/GF3	220.0		900	7.50	70				
ELJRE3N6D/ZF2	3.6		±0.3 nH	9	100	5500	0.14	500	
ELJRE4N3J/ZF2	4.3					5100	0.16	450	
ELJRE5N1J/ZF2	5.1			±0.2 nH		9	4700	0.18	450
ELJRE6N2J/ZF2	6.2						4000	0.19	450
ELJRE7N5J/ZF2	7.5			±5 %		10	3500	0.24	430
ELJRE9N1J/ZF2	9.1	3100					0.30	430	
ELJRE11NJ/GF2	11.0	±2 %		10		2800	0.33	400	
ELJRE13NJ/GF2	13.0					2600	0.38	400	
ELJRE16NJ/GF2	16.0	±0.2 nH		9		2400	0.43	400	
ELJRE20NJ/GF2	20.0					2100	0.48	350	
ELJRE24NJ/GF2	24.0	±5 %	4	2000	0.53	300			
ELJRE30NJ/GF2	30.0			1900	0.58	300			
ELJRE36NJ/GF2	36.0		±2 %	10	1800	0.70	300		
ELJRE43NJ/GF2	43.0				1800	0.87	300		

*1 : Self Resonant Frequency *2 : DC Resistance

■ Type 1005(0402)NK

● Dimensions in mm (not to scale)

● Recommended Land Pattern in mm (not to scale)

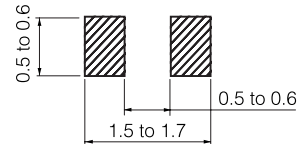
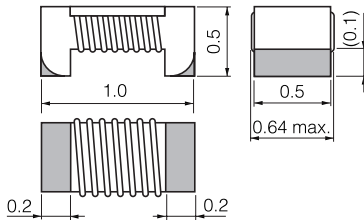

■ Standard Packing Quantity

● 10000 pcs./Reel

■ Examples

Part No.	Inductance		Q min.	L, Q Test Freq. (MHz)	SRF *1 (MHz)min.	DCR *2 (Ω)max.	DC Current (mA)max.
	(nH)	Tolerance					
ELJNK2N2E/ZF	2.2	±0.5 nH ±0.2 nH	20	250	15000	0.05	900
ELJNK2N7E/ZF	2.7				15000	0.05	900
ELJNK3N3E/ZF	3.3				12000	0.07	850
ELJNK3N9E/ZF	3.9		10000		0.07	850	
ELJNK4N3E/ZF	4.3		10000		0.07	850	
ELJNK4N7E/ZF	4.7		8000		0.07	850	
ELJNK5N1E/ZF	5.1		8000		0.12	680	
ELJNK5N6E/ZF	5.6		8000		0.09	750	
ELJNK6N2E/ZF	6.2		8000		0.09	750	
ELJNK6N8J/AF	6.8	±5 % ±3 %	26		6500	0.09	750
ELJNK7N5J/AF	7.5				6500	0.13	660
ELJNK8N2J/AF	8.2				6500	0.12	680
ELJNK9N1J/AF	9.1				5500	0.14	640
ELJNK10NJ/AF	10.0				5500	0.14	640
ELJNK12NJ/AF	12.0				5500	0.14	640
ELJNK15NJ/AF	15.0		5200		0.16	560	
ELJNK18NJ/AF	18.0		4800		0.27	430	
ELJNK22NJ/AF	22.0		4100		0.30	410	
ELJNK27NJ/AF	27.0		4000		0.47	350	
ELJNK33NJ/AF	33.0		3500		0.53	310	
ELJNK39NJ/AF	39.0		3200		0.70	270	
ELJNK47NJ/AF	47.0	25	200	3000	1.05	220	
ELJNK56NJ/AF	56.0			2800	1.10	210	

*1 : Self Resonant Frequency *2 : DC Resistance

Design and specifications are each subject to change without notice. Ask factory for the current technical specifications before purchase and/or use. Should a safety concern arise regarding this product, please be sure to contact us immediately.

■ Type 1608(0603)NJ

● Dimensions in mm (not to scale)

● Recommended Land Pattern in mm (not to scale)

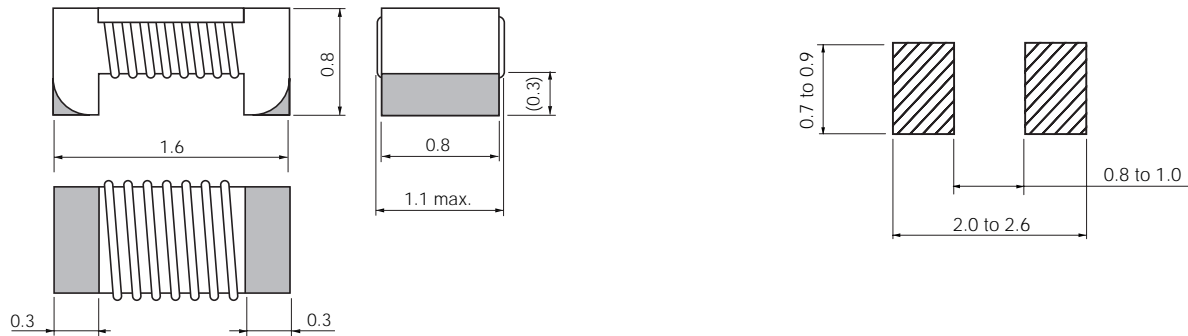

■ Standard Packing Quantity

● 3000 pcs./Reel

■ Examples

Part No.	Inductance		Q min.	L, Q Test Freq. (MHz)	SRF *1 (MHz)min.	DCR *2 (Ω)max.	DC Current (mA)max.
	(nH)	Tolerance					
ELJNJ6N8Z/EF2	6.8	±0.2 nH	35	250	6000	0.08	750
ELJNJ8N2Z/EF2	8.2	±0.5 nH			6000	0.10	650
ELJNJ10NG/JF2	10.0	±2 % ±5 %			6000	0.10	650
ELJNJ12NG/JF2	12.0		6000		0.13	600	
ELJNJ15NG/JF2	15.0		5000		0.13	600	
ELJNJ18NG/JF2	18.0		5000		0.15	550	
ELJNJ22NG/JF2	22.0		4600	0.17	500		
ELJNJ27NG/JF2	27.0		3800	0.20	440		
ELJNJ33NG/JF2	33.0	±2 % ±5 %	40	200	3500	0.23	420
ELJNJ39NG/JF2	39.0				3200	0.25	400
ELJNJ47NG/JF2	47.0				3000	0.28	380
ELJNJ56NG/JF2	56.0		38		2700	0.30	360
ELJNJ68NG/JF2	68.0		34		2300	0.35	340
ELJNJ82NG/JF2	82.0				2200	0.48	290
ELJNJR10G/JF2	100.0	150		2000	0.62	250	
ELJNJR12G/JF2	120.0		32	1700	0.90	210	
ELJNJR15G/JF2	150.0			1400	1.30	160	
ELJNJR18G/JF2	180.0	25	100	1300	2.00	140	
ELJNJR22G/JF2	220.0			1200	2.20	120	

*1 : Self Resonant Frequency *2 : DC Resistance

■ Type 2012(0805)ND

● Dimensions in mm (not to scale)

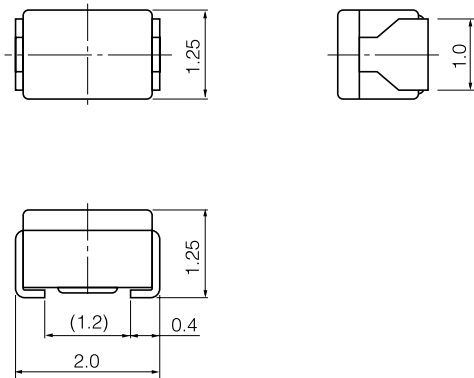

● Recommended Land Pattern in mm (not to scale)

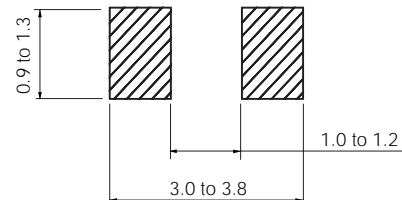

■ Standard Packing Quantity

- 3000 pcs./Reel

■ Examples

Part No.	Inductance		Q min.	L, Q Test Freq. (MHz)	Q Typical (800 MHz)	SRF* ¹ (MHz)min.	DCR* ² (Ω)max.	DC Current (mA)max.	
	(nH)	Tolerance							
ELJND10NKF	10	±10 %	10	100	72	3300	0.18	540	
ELJND12NKF	12				67	3300	0.24	535	
ELJND15NKF	15		12		73	3000	0.24	520	
ELJND18NKF	18				74	3000	0.29	480	
ELJND22NKF	22		15		15	75	2600	0.29	465
ELJND27NKF	27					73	2500	0.34	455
ELJND33NJ/KF	33					80	2050	0.39	395
ELJND39NJ/KF	39					72	2000	0.41	390
ELJND47NJ/KF	47					71	1650	0.46	385
ELJND56NJ/KF	56					63	1550	0.51	360
ELJND68NJ/KF	68		± 5 % ±10 %		10	57	1450	0.57	340
ELJND82NJ/KF	82					56	1100	0.63	330
ELJNDR10J/KF	100	8		25.2		51	800	0.86	285
ELJNDR12J/KF	120					32	600	0.99	275
ELJNDR15J/KF	150	10				36	600	1.47	230
ELJNDR18J/KF	180					34	600	1.61	195
ELJNDR22J/KF	220					—	500	1.84	170
ELJNDR27J/KF	270					—	300	1.95	165
ELJNDR33J/KF	330					—	200	2.16	160
ELJNDR39J/KF	390					—	150	2.37	150
ELJNDR47J/KF	470		—		150	2.56	145		
ELJNDR56J/KF	560		—		100	2.69	140		
ELJNDR68J/KF	680	—	100	3.02	130				
ELJNDR82J/KF	820	—	80	3.38	125				
ELJND1R0J/KF	1000	8	7.96	—	80	3.88	120		

*1 : Self Resonant Frequency *2 : DC Resistance

■ Type 2520(1008)NC

● Dimensions in mm (not to scale)

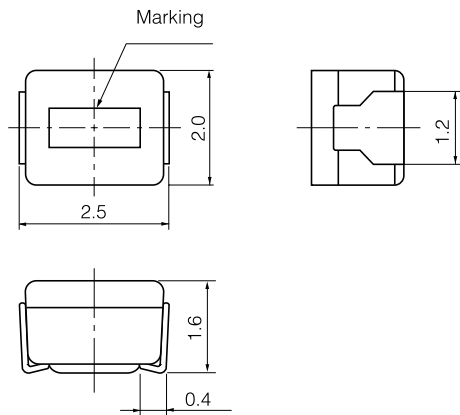

● Recommended Land Pattern in mm (not to scale)

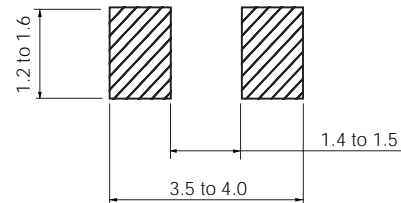

■ Standard Packing Quantity

- 2000 pcs./Reel

■ Examples

Part No.	Inductance		Q min.	L, Q Test Freq. (MHz)	SRF *1 (MHz)min.	DCR *2 (Ω)max.	DC Current (mA)max.			
	(nH)	Tolerance								
ELJNC10NKF	10	± 10 %	10	100	2500	0.32	280			
ELJNC12NKF	12				2200	0.34	270			
ELJNC15NKF	15				1800	0.38	255			
ELJNC18NKF	18				1550	0.40	250			
ELJNC22NKF	22				1350	0.43	240			
ELJNC27NKF	27				1150	0.47	230			
ELJNC33NK/JF	33	± 10 %	15	100	1000	0.51	220			
ELJNC39NK/JF	39				890	0.55	215			
ELJNC47NK/JF	47				770	0.59	205			
ELJNC56NK/JF	56				670	0.63	200			
ELJNC68NK/JF	68				590	0.68	190			
ELJNC82NK/JF	82				520	0.73	185			
ELJNCR10K/JF	100				± 5 %	10	25.2	460	0.80	175
ELJNCR12K/JF	120							400	0.87	170
ELJNCR15K/JF	150							340	0.98	160
ELJNCR18K/JF	180							300	1.05	155
ELJNCR22K/JF	220							260	1.15	145
ELJNCR27K/JF	270							230	1.25	140
ELJNCR33K/JF	330	200	1.37	135						
ELJNCR39K/JF	390	180	1.47	130						
ELJNCR47K/JF	470	160	1.58	125						
ELJNCR56K/JF	560	145	1.70	120						
ELJNCR68K/JF	680	130	1.85	110						
ELJNCR82K/JF	820	100	2.10	100						

*1 : Self Resonant Frequency *2 : DC Resistance

■ Type 3225(1210)NA

● Dimensions in mm (not to scale)

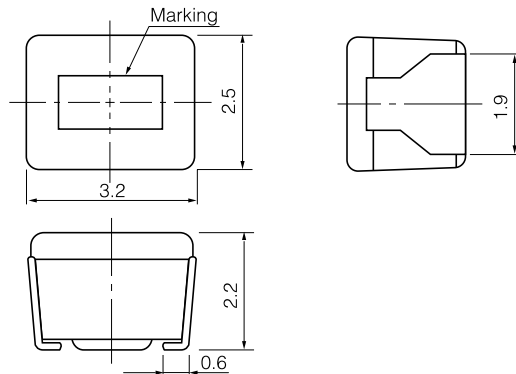

● Recommended Land Pattern in mm (not to scale)

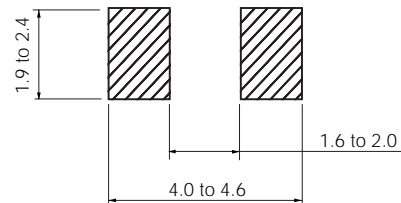

■ Standard Packing Quantity

- 2000 pcs./Reel

■ Examples

Part No.	Inductance			Q		SRF* ¹ (MHz)min.	DCR* ² (Ω)max.	DC Current (mA)max.
	(μH)	Freq. (MHz)	Tolerance	min.	Freq. (MHz)			
ELJNA47NMF	0.047	100	±20 %	10	100	680	0.20	450
ELJNA56NMF	0.056					600	0.22	420
ELJNA68NMF	0.068					540	0.25	400
ELJNA82NMF	0.082					500	0.27	380
ELJNAR10MF	0.100					450	0.30	360
ELJNAR12MF	0.120	25.2	±10 %	10	25.2	400	0.67	240
ELJNAR15MF	0.150					350	0.72	230
ELJNAR18MF	0.180					320	0.81	220
ELJNAR22KF	0.220					280	0.90	210
ELJNAR27KF	0.270					250	1.00	200
ELJNAR33KF	0.330	1.0	±10 %	10	25.2	220	1.10	190
ELJNAR39KF	0.390					200	1.20	180
ELJNAR47KF	0.470					180	1.40	175
ELJNAR56KF	0.560					160	1.50	170
ELJNAR68KF	0.680					150	1.70	155
ELJNAR82KF	0.820	1.0	±5 %	13	7.96	135	1.90	145
ELJNA1R0JF	1.000					120	2.10	125
ELJNA1R2JF	1.200					110	2.30	120
ELJNA1R5JF	1.500					95	2.70	115
ELJNA1R8JF	1.800					85	3.00	110
ELJNA2R2JF	2.200	1.0	±5 %	13	7.96	80	3.20	110
ELJNA2R7JF	2.700					70	3.60	105
ELJNA3R3JF	3.300					62	4.20	100
ELJNA3R9JF	3.900					57	4.40	95
ELJNA4R7JF	4.700					52	7.70	70
ELJNA5R6JF	5.600	1.0	±5 %	13	7.96	46	8.70	65
ELJNA6R8JF	6.800					42	10.00	60
ELJNA8R2JF	8.200					38	11.00	60

*1 : Self Resonant Frequency *2 : DC Resistance

Design and specifications are each subject to change without notice. Ask factory for the current technical specifications before purchase and/or use. Should a safety concern arise regarding this product, please be sure to contact us immediately.

2. Type Non Wound (High-Q) QF, QE

■ Type 1005(0402)QF

● Dimensions in mm (not to scale)

● Recommended Land Pattern in mm (not to scale)



■ Standard Packing Quantity

● 10000 pcs./Reel

■ Examples

Part No.	Inductance			Q		SRF *1 (MHz)min.	DCR *2 (Ω)max.	DC Current (mA)max.					
	(μH)	Tolerance	Freq. (MHz)	100 MHz min.	800 MHz typ.								
ELJQF1N0D/ZF	1.0	±0.3 nH	±0.2 nH	100	10	41	6000	400					
ELJQF1N2D/ZF	1.2						6000	400					
ELJQF1N5D/ZF	1.5						40	6000	400				
ELJQF1N8D/ZF	1.8							6000	400				
ELJQF2N2D/ZF	2.2							6000	400				
ELJQF2N7D/ZF	2.7							5500	400				
ELJQF3N3D/ZF	3.3						±5 %	±2 %	100	10	39	5500	400
ELJQF3N9D/ZF	3.9											5200	360
ELJQF4N7D/ZF	4.7											4800	360
ELJQF5N6D/ZF	5.6											4600	340
ELJQF6N8J/ZF	6.8	4000	320										
ELJQF8N2J/ZF	8.2	3500	320										
ELJQF10NJ/GF	10.0	2800	320										
ELJQF12NJ/GF	12.0	38	2800	320									
ELJQF15NJ/GF	15.0		2500	0.60	240								
ELJQF18NJ/GF	18.0			2200	0.70	240							
ELJQF22NJ/GF	22.0				2200	200							
ELJQF27NJ/GF	27.0	1800	1.20	200									
ELJQF33NJ/GF	33.0		1800	1.40	170								
ELJQF39NJ/GF	39.0			1800	150								

*1 : Self Resonant Frequency *2 : DC Resistance

■ Type 1608(0603)QE

● Dimensions in mm (not to scale)

● Recommended Land Pattern in mm (not to scale)



■ Standard Packing Quantity

● 3000 pcs./Reel

■ Examples

Part No.	Inductance			Q		SRF *1 (MHz)min.	DCR *2 (Ω)max.	DC Current (mA)max.	
	(μH)	Tolerance	Freq. (MHz)	100 MHz min.	800 MHz typ.				
ELJQE1N0D/ZF	1.0	±0.3 nH	250	16	250	6000	0.05	500	
ELJQE1N2D/ZF	1.2					6000	0.06	500	
ELJQE1N5D/ZF	1.5					20	6000	0.07	500
ELJQE1N8D/ZF	1.8					25	6000	0.08	500
ELJQE2N2D/ZF	2.2					25	6000	0.09	500
ELJQE2N7D/ZF	2.7					25	6000	0.10	500
ELJQE3N3D/ZF	3.3					28	5500	0.12	500
ELJQE3N9D/ZF	3.9					28	5500	0.15	450
ELJQE4N7D/ZF	4.7					30	4800	0.17	450
ELJQE5N6D/ZF	5.6					30	4600	0.18	430
ELJQE6N8J/ZF	6.8	±5 %	250	30	250	3550	0.20	430	
ELJQE8N2J/ZF	8.2					3500	0.28	400	
ELJQE10NJ/GF	10.0					2800	0.32	400	
ELJQE12NJ/GF	12.0					2800	0.35	400	
ELJQE15NJ/GF	15.0					2500	0.41	350	
ELJQE18NJ/GF	18.0					2300	0.45	350	
ELJQE22NJ/GF	22.0					2000	0.50	300	
ELJQE27NJ/GF	27.0					2000	0.55	300	
ELJQE33NJ/GF	33.0					1800	0.60	300	
ELJQE39NJ/GF	39.0					1800	0.80	300	
ELJQE47NJ/GF	47.0	±2 %	200	27	200	1800	0.95	250	
ELJQE56NJ/GF	56.0					1800	1.20	250	
ELJQE68NJ/GF	68.0					1500	1.30	250	

*1 : Self Resonant Frequency *2 : DC Resistance

3. Normal Types FJ, FC, FA, FB

■ Type 1608(0603)FJ

● Dimensions in mm (not to scale)

● Recommended Land Pattern in mm (not to scale)

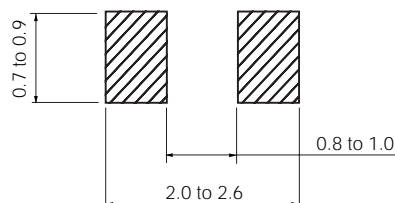
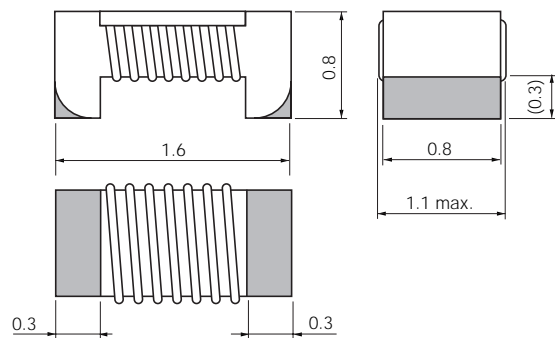

■ Standard Packing Quantity

● 3000 pcs./Reel

■ Examples

Part No.	Inductance		Q min.	L, Q Test Freq. (MHz)	SRF*1 (MHz)min.	DCR*2 (Ω)max.	DC Current (mA)max.
	(nH)	Tolerance					
ELJFJR10JF2	100	± 5%	40	150	1600	0.30	400
ELJFJR12JF2	120				1500	0.37	360
ELJFJR15JF2	150				1350	0.60	280
ELJFJR18JF2	180		35	100	1250	0.68	270
ELJFJR22JF2	220				1150	1.06	210
ELJFJR27JF2	270				1150	1.40	180
ELJFJR33JF2	330				1100	1.66	160
ELJFJR39JF2	390				900	2.25	140

*1 : Self Resonant Frequency *2 : DC Resistance

■ Type 2520(1008)FC

● Dimensions in mm (not to scale)

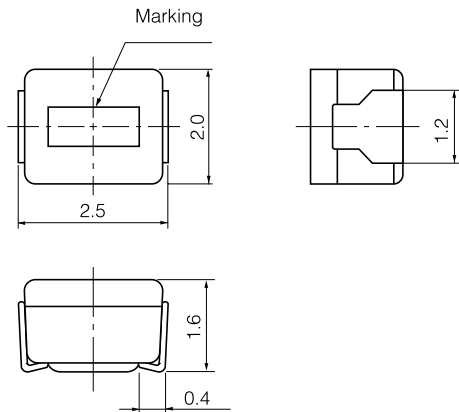

● Recommended Land Pattern in mm (not to scale)

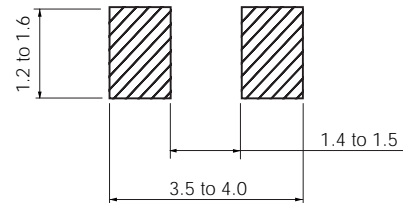

■ Standard Packing Quantity

- 2000 pcs./Reel

■ Examples

Part No.	Inductance		Q min.	L, Q Test Freq. (MHz)	SRF* ¹ (MHz)min.	DCR* ² (Ω)max.	DC Current (mA)max.
	(μH)	Tolerance					
ELJFCR22M/KF	0.22	±20 % ±10 %	25	25.2	230	0.70	190
ELJFCR27M/KF	0.27				210	0.75	180
ELJFCR33M/KF	0.33				190	0.85	170
ELJFCR39M/KF	0.39				175	0.95	160
ELJFCR47M/KF	0.47				160	1.00	155
ELJFCR56M/KF	0.56				150	1.10	150
ELJFCR68M/KF	0.68				135	1.25	140
ELJFCR82M/KF	0.82				125	1.40	130
ELJFC1R0K/JF	1.00	±10 % ±5 %	25	7.96	115	0.65	195
ELJFC1R2K/JF	1.20				100	0.75	180
ELJFC1R5K/JF	1.50				90	0.85	170
ELJFC1R8K/JF	1.80				85	0.95	160
ELJFC2R2K/JF	2.20				80	1.05	155
ELJFC2R7K/JF	2.70				75	1.20	145
ELJFC3R3K/JF	3.30				65	1.30	135
ELJFC3R9K/JF	3.90				60	1.40	130
ELJFC4R7K/JF	4.70				55	1.55	125
ELJFC5R6K/JF	5.60			50	1.75	120	
ELJFC6R8K/JF	6.80			45	1.95	115	
ELJFC8R2K/JF	8.20			40	2.20	105	
ELJFC100K/JF	10.00			32	3.50	80	
ELJFC120K/JF	12.00			30	3.80	75	
ELJFC150K/JF	15.00			28	4.40	70	
ELJFC180K/JF	18.00			25	5.00	65	
ELJFC220K/JF	22.00			22	5.80	60	
ELJFC270K/JF	27.00			20	2.52	21	6.30
ELJFC330K/JF	33.00	20	7.10			110	
ELJFC390K/JF	39.00	18	9.50			90	
ELJFC470K/JF	47.00	17	11.00			80	
ELJFC560K/JF	56.00	16	12.10			75	
ELJFC680K/JF	68.00	15	16.60			70	
ELJFC820K/JF	82.00	13	19.00			65	
ELJFC101K/JF	100.00	15	0.796			12	21.00

*1 : Self Resonant Frequency *2 : DC Resistance

■ Type 3225(1210)FA

● Dimensions in mm (not to scale)

● Recommended Land Pattern in mm (not to scale)

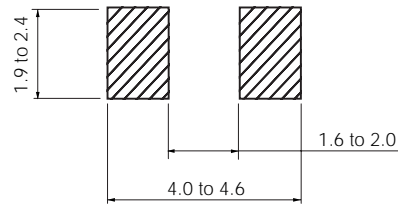
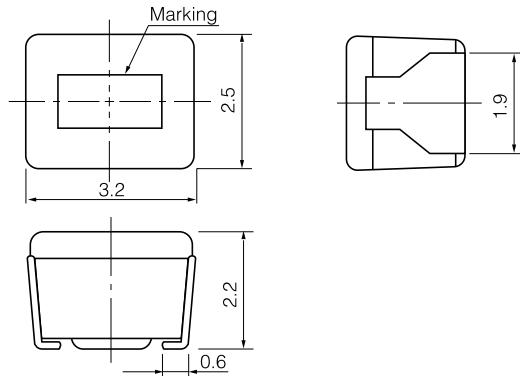

■ Standard Packing Quantity

● 2000 pcs./Reel

■ Examples

Part No.	Inductance		Q min.	L, Q Test Freq. (MHz)	SRF*1 (MHz)min.	DCR*2 (Ω)max.	DC Current (mA)max.
	(μH)	Tolerance					
ELJFAR22M/KF2	0.22	±20 % ±10 %	25	25.2	230	0.29	360
ELJFAR27M/KF2	0.27				210	0.32	345
ELJFAR33M/KF2	0.33				190	0.35	330
ELJFAR39M/KF2	0.39				175	0.39	305
ELJFAR47M/KF2	0.47				160	0.44	290
ELJFAR56M/KF2	0.56				150	0.49	275
ELJFAR68M/KF2	0.68				135	0.55	260
ELJFAR82M/KF2	0.82				125	0.61	245
ELJFA1R0K/JF2	1.00	±10 % ±5 %	30	7.96	115	0.69	230
ELJFA1R2K/JF2	1.20				100	0.75	215
ELJFA1R5K/JF	1.50				90	0.75	210
ELJFA1R8K/JF	1.80				85	0.82	200
ELJFA2R2K/JF	2.20				80	0.95	190
ELJFA2R7K/JF	2.70				75	1.10	180
ELJFA3R3K/JF	3.30				65	1.20	180
ELJFA3R9K/JF	3.90				60	1.30	175
ELJFA4R7K/JF	4.70				55	1.50	165
ELJFA5R6K/JF	5.60				50	1.60	160
ELJFA6R8K/JF	6.80			45	1.80	150	
ELJFA8R2K/JF	8.20			40	2.00	140	
ELJFA100K/JF	10.00			36	2.10	140	
ELJFA120K/JF	12.00			33	2.50	125	
ELJFA150K/JF	15.00			30	2.80	120	
ELJFA180K/JF	18.00			27	3.30	110	
ELJFA220K/JF	22.00			25	3.70	105	
ELJFA270K/JF	27.00			22	5.00	90	
ELJFA330K/JF	33.00			20	5.60	85	
ELJFA390K/JF	39.00			20	6.40	80	
ELJFA470K/JF	47.00	15	7.00	75			
ELJFA560K/JF	56.00	15	8.00	70			
ELJFA680K/JF	68.00	15	9.00	65			
ELJFA820K/JF	82.00	11	10.00	60			
ELJFA101K/JF	100.00	10	10.00	60			
ELJFA121K/JF	120.00	10	11.00	55			
ELJFA151K/JF	150.00	8	15.00	50			
ELJFA181K/JF	180.00	7	17.00	50			
ELJFA221K/JF	220.00	7	21.00	45			

*1 : Self Resonant Frequency *2 : DC Resistance

Design and specifications are each subject to change without notice. Ask factory for the current technical specifications before purchase and/or use. Should a safety concern arise regarding this product, please be sure to contact us immediately.

■ Type 4532(1812)FB

● Dimensions in mm (not to scale)

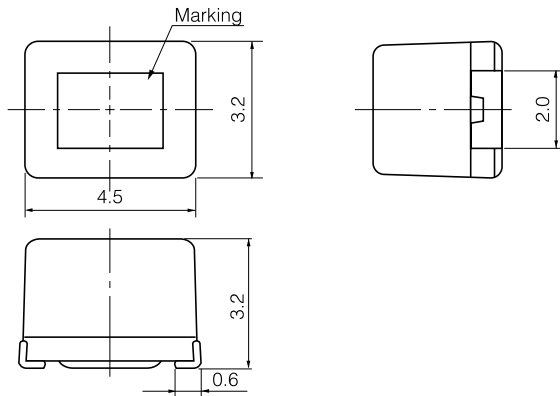

● Recommended Land Pattern in mm (not to scale)

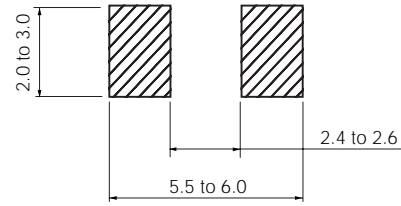

■ Standard Packing Quantity

● 500 pcs./Reel

■ Examples

Part No.	Inductance			Q		SRF *1 (MHz)min.	DCR *2 (Ω)max.	DC Current (mA)max.
	(μH)	Freq. (MHz)	Tolerance	min.	Freq. (MHz)			
ELJFBR22MF	0.22	1.0	±20 %	30	25.2	230.0	0.30	700
ELJFBR27MF	0.27					200.0	0.32	650
ELJFBR33MF	0.33					180.0	0.35	630
ELJFBR39MF	0.39					155.0	0.37	620
ELJFBR47MF	0.47					135.0	0.40	580
ELJFBR56MF	0.56					120.0	0.42	560
ELJFBR68MF	0.68					105.0	0.48	530
ELJFBR82MF	0.82					90.0	0.50	500
ELJFB1R0M/KF	1.00					80.0	0.52	470
ELJFB1R2M/KF	1.20					70.0	0.55	460
ELJFB1R5M/KF	1.50		60.0	0.61	430			
ELJFB1R8M/KF	1.80		50.0	0.61	410			
ELJFB2R2M/KF	2.20		±20 %	50	7.96	45.0	0.61	410
ELJFB2R7M/KF	2.70					43.0	0.61	400
ELJFB3R3M/KF	3.30					39.0	0.66	380
ELJFB3R9M/KF	3.90					36.0	0.74	360
ELJFB4R7M/KF	4.70					33.0	0.81	350
ELJFB5R6M/KF	5.60					30.0	0.88	330
ELJFB6R8M/KF	6.80					26.0	1.00	310
ELJFB8R2M/KF	8.20					24.0	1.60	250
ELJFB100K/JF	10.00	22.0				1.80	235	
ELJFB120K/JF	12.00	20.0				1.90	225	
ELJFB150K/JF	15.00	18.0	2.10	215				
ELJFB180K/JF	18.00	16.0	2.30	205				
ELJFB220K/JF	22.00	±10 %	40	2.52	15.0	2.60	195	
ELJFB270K/JF	27.00				13.0	2.90	185	
ELJFB330K/JF	33.00				12.0	3.10	175	
ELJFB390K/JF	39.00				10.0	3.60	165	
ELJFB470K/JF	47.00				9.0	4.20	130	
ELJFB560K/JF	56.00				9.0	4.70	125	
ELJFB680K/JF	68.00				8.2	5.30	115	
ELJFB820K/JF	82.00				7.5	5.90	110	
ELJFB101K/JF	100.00				6.7	8.80	105	
ELJFB121K/JF	120.00				6.1	10.00	100	
ELJFB151K/JF	150.00	±5 %	30	1.5	5.5	11.00	95	
ELJFB181K/JF	180.00				5.1	13.00	85	
ELJFB221K/JF	220.00				4.5	13.00	85	
ELJFB271K/JF	270.00				4.1	14.00	80	
ELJFB331K/JF	330.00				3.7	16.00	75	
ELJFB391K/JF	390.00				3.3	19.00	70	
ELJFB471K/JF	470.00				3.3	31.00	55	
ELJFB561K/JF	560.00				2.7	35.00	50	
ELJFB681K/JF	680.00				2.5	39.00	50	
ELJFB821K/JF	820.00				2.4	45.00	45	
ELJFB102K/JF	1000.00	2.1	53.00	40				

*1 : Self Resonant Frequency *2 : DC Resistance

4. Magnetic Shielded Type SA

■ Type 3225(1210)SA

● Dimensions in mm (not to scale)

● Recommended Land Pattern in mm (not to scale)

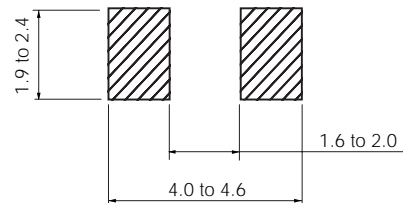
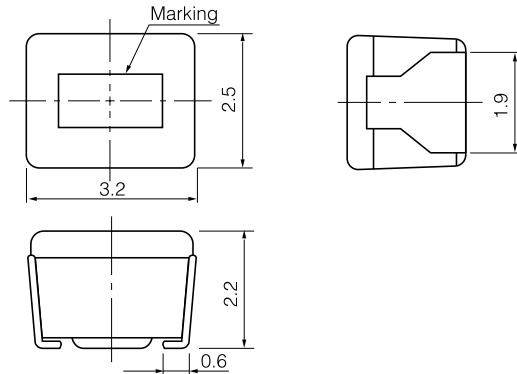

■ Standard Packing Quantity

● 2000 pcs./1 reel

■ Examples

Part No.	Inductance			Q		SRF *1 (MHz)min.	DCR *2 (Ω)max.	DC Current (mA)max.
	(μH)	Freq. (MHz)	Tolerance	min.	Freq. (MHz)			
ELJSA100KF	10	1.0	±10 %	40	5.0	30	1.8	18
ELJSA120KF	12					28	2.0	17
ELJSA150KF	15					25	2.2	15
ELJSA180KF	18					23	2.5	13
ELJSA220KF	22					20	2.8	12
ELJSA270KF	27					18	3.2	10
ELJSA330KF	33					17	3.5	10
ELJSA390KF	39				15	3.8	9	
ELJSA470KF	47				14	4.0	8	
ELJSA560KF	56				13	4.5	7	
ELJSA680KF	68				1.5	12	5.0	6
ELJSA820KF	82					11	6.0	6
ELJSA101KF	100					10	7.0	5
ELJSA121KF	120					9	8.0	5
ELJSA151KF	150	5	9.0	5				
ELJSA181KF	180	5	11.0	5				
ELJSA221KF	220	4	12.0	5				
ELJSA271KF	270	0.1	4	14.0	5			

*1 : Self Resonant Frequency *2 : DC Resistance

5. High Power Types PF, PE, PC, PA, PB

■ Type 1005(0402)PF

● Dimensions in mm (not to scale)

● Recommended Land Pattern in mm (not to scale)

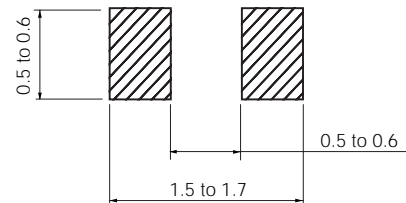
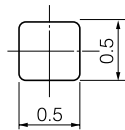
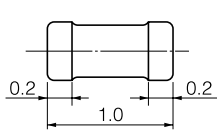

■ Standard Packing Quantity

● 10000 pcs./Reel

■ Examples

Part No.	Inductance		Q min.	L, Q Test Freq. (MHz)	SRF *1 (MHz)min.	DCR *2 (Ω)max.	DC Current (mA)max.
	(nH)	Tolerance					
ELJPF2N2DF	2.2	± 0.3 nH	7	100	5300	0.04	1900
ELJPF2N7DF	2.7				5300	0.05	1800
ELJPF3N3DF	3.3				5000	0.07	1500
ELJPF3N9DF	3.9				4800	0.08	1400
ELJPF4N7DF	4.7				4600	0.10	1300
ELJPF5N6DF	5.6				4200	0.12	1200
ELJPF6N8JF	6.8	± 5 %			4000	0.16	1100
ELJPF8N2JF	8.2				3700	0.21	900
ELJPF10NJF	10.0				3200	0.26	750

*1 : Self Resonant Frequency *2 : DC Resistance

■ Type 1608(0603)PE

● Dimensions in mm (not to scale)

● Recommended Land Pattern in mm (not to scale)

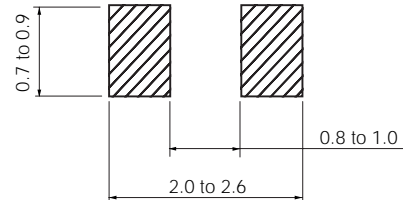
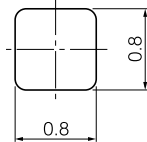
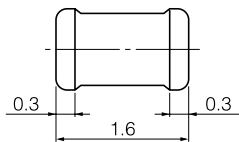

■ Standard Packing Quantity

● 3000 pcs./Reel

■ Examples

Part No.	Inductance		Q min.	L, Q Test Freq. (MHz)	SRF *1 (MHz) min.	DCR *2 (Ω) max.	DC Current (mA) max.
	(nH)	Tolerance					
ELJPE2N2KF	2.2	± 10 %	8	100	6000	0.030	2100
ELJPE2N7KF	2.7				5500	0.030	2100
ELJPE3N3KF	3.3				5500	0.040	2100
ELJPE3N9KF	3.9		5200		0.040	2100	
ELJPE4N7KF	4.7		4800		0.050	2100	
ELJPE5N6KF	5.6		4600		0.055	2100	
ELJPE6N8KF	6.8		4000		0.055	1900	
ELJPE8N2KF	8.2		3500		0.060	1700	
ELJPE10NKF	10.0		2800		0.065	1400	
ELJPE12NKF	12.0		2500		0.080	1300	
ELJPE15NKF	15.0		2200		0.100	900	
ELJPE18NKF	18.0		2000		0.120	800	
ELJPE22NKF	22.0		1800		0.150	700	

*1 : Self Resonant Frequency *2 : DC Resistance

■ Type 2520(1008)PC

● Dimensions in mm (not to scale)

● Recommended Land Pattern in mm (not to scale)

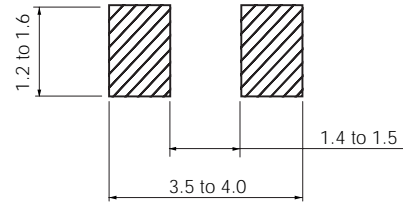
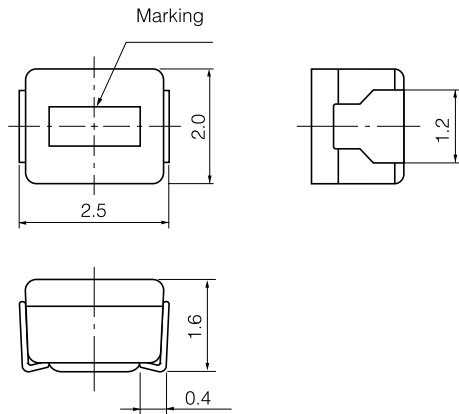

■ Standard Packing Quantity

● 2000 pcs./Reel

■ Examples

Part No.	Inductance		Q min.	L, Q Test Freq. (MHz)	SRF* ¹ (MHz)min.	DCR* ² (Ω)max.	DC Current (mA)max.
	(μH)	Tolerance					
ELJPC1R0MF	1.0	±20 %	10	7.96	95	0.45	475
ELJPC1R5MF	1.5				85	0.55	435
ELJPC2R2MF	2.2				65	0.65	390
ELJPC3R3MF	3.3				55	0.85	340
ELJPC4R7MF	4.7				43	1.20	285
ELJPC6R8KF	6.8	±10 %	8.5	2.52	44	1.30	170
ELJPC100KF	10.0		20		32	2.20	210
ELJPC120KF	12.0				25	2.70	195
ELJPC150KF	15.0				21	3.20	175
ELJPC220KF	22.0				18	4.00	160
ELJPC330KF	33.0				16	6.50	120

*1 : Self Resonant Frequency *2 : DC Resistance

■ Type 3225(1210)PA

● Dimensions in mm (not to scale)

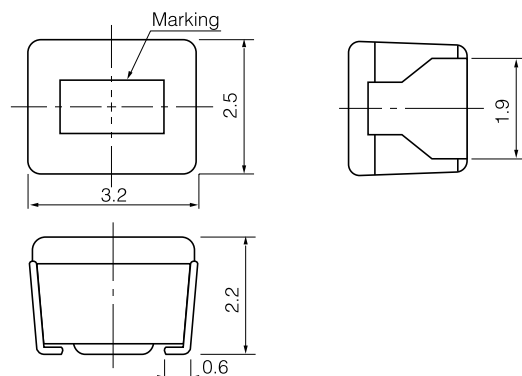

● Recommended Land Pattern in mm (not to scale)

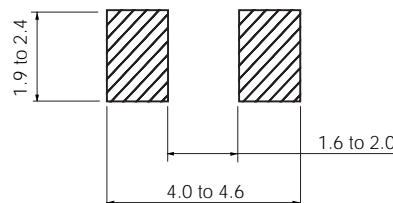

■ Standard Packing Quantity

● 2000 pcs./Reel

■ Examples

Part No.	Inductance		Q min.	L, Q Test Freq. (MHz)	SRF *1 (MHz)min.	DCR *2 (Ω)max.	DC Current (mA)max.		
	(μH)	Tolerance							
ELJPA1R0MF	1.0	±20 %	7	7.96	150.0	0.15	600		
ELJPA1R5MF	1.5				110.0	0.18	550		
ELJPA2R2MF	2.2				80.0	0.23	500		
ELJPA3R3MF	3.3				58.0	0.28	400		
ELJPA4R7MF	4.7				46.0	0.34	350		
ELJPA6R8MF	6.8				38.0	0.42	300		
ELJPA100KF	10.0	±10 %	15	2.52	23.0	0.50	240		
ELJPA120KF	12.0				21.0	0.60	230		
ELJPA150KF	15.0				18.0	0.74	220		
ELJPA180KF	18.0				17.0	0.90	205		
ELJPA220KF	22.0				15.0	1.15	185		
ELJPA270KF	27.0				13.0	1.45	165		
ELJPA330KF	33.0				12.0	1.65	155		
ELJPA390KF	39.0				11.0	1.90	145		
ELJPA470KF	47.0				9.5	2.25	135		
ELJPA560KF	56.0				8.5	3.30	110		
ELJPA680KF	68.0				7.5	3.70	105		
ELJPA820KF	82.0				7.0	4.20	100		
ELJPA101KF	100.0				20	0.796	6.5	5.00	90
ELJPA121KF	120.0						6.0	7.00	75
ELJPA151KF	150.0	5.5	8.00	70					
ELJPA181KF	180.0	5.0	9.50	65					
ELJPA221KF	220.0	4.0	11.00	60					
ELJPA271KF	270.0	3.5	14.50	55					
ELJPA331KF	330.0	3.0	16.00	50					

*1 : Self Resonant Frequency *2 : DC Resistance

■ Type 4532(1812)PB

● Dimensions in mm (not to scale)

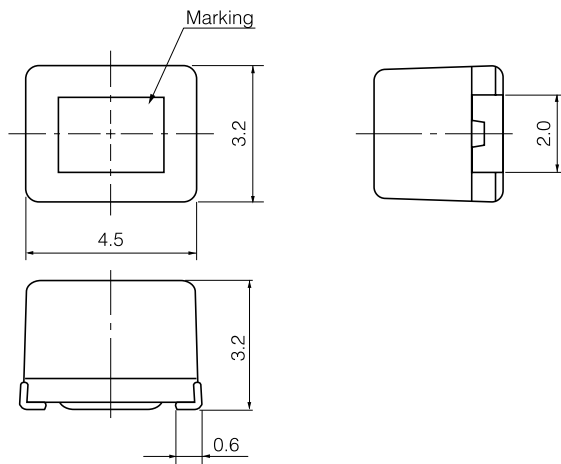

● Recommended Land Pattern in mm (not to scale)

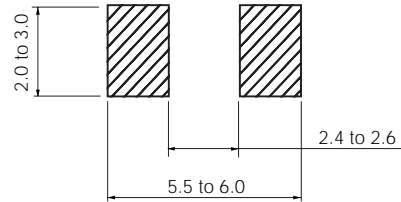

■ Standard Packing Quantity

- 500 pcs./Reel

■ Examples

Part No.	Inductance		Q min.	L, Q Test Freq. (MHz)	SRF *1 (MHz)min.	DCR *2 (Ω)max.	DC Current (mA)max.		
	(μH)	Tolerance							
ELJPB100KF	10	±10 %	10	2.52	19.0	0.65	360		
ELJPB120KF	12				17.0	0.70	340		
ELJPB150KF	15				15.0	0.80	320		
ELJPB180KF	18				14.0	0.90	310		
ELJPB220KF	22				13.0	1.00	300		
ELJPB270KF	27				11.0	1.20	270		
ELJPB330KF	33				10.0	1.40	250		
ELJPB390KF	39				9.5	1.60	230		
ELJPB470KF	47				8.5	1.90	210		
ELJPB560KF	56				8.0	2.20	190		
ELJPB680KF	68				7.0	2.60	170		
ELJPB820KF	82				6.5	3.50	160		
ELJPB101KF	100				20	0.796	6.0	4.00	150
ELJPB121KF	120						5.5	4.50	130
ELJPB151KF	150						5.0	6.50	120
ELJPB181KF	180	4.5	7.50	110					
ELJPB221KF	220	4.0	9.00	90					

*1 : Self Resonant Frequency *2 : DC Resistance

6. Low DC resistance Type EA

■ Type 3225(1210)EA

● Dimensions in mm (not to scale)

● Recommended Land Pattern in mm (not to scale)

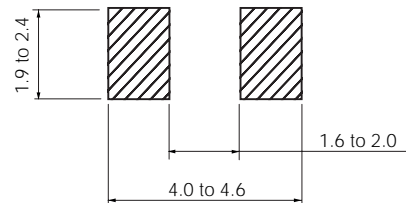
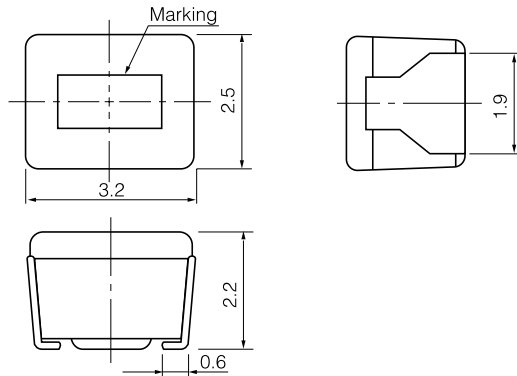

■ Standard Packing Quantity

● 2000 pcs./Reel



■ Examples

Part No.	Inductance		Q min.	L, Q Test Freq. (MHz)	SRF *1 (MHz)min.	DCR *2 (Ω)max.	DC Current (mA)max.
	(μH)	Tolerance					
ELJEA1R0MF	1.0	±20 %	7	7.96	100.0	0.09	500
ELJEA1R5MF	1.5				80.0	0.10	390
ELJEA2R2MF	2.2				65.0	0.13	350
ELJEA3R3MF	3.3				50.0	0.16	270
ELJEA4R7MF	4.7				46.0	0.18	240
ELJEA6R8MF	6.8				36.0	0.25	200
ELJEA100KF	10.0	±10 %	10	2.52	29.0	0.34	160
ELJEA150KF	15.0				25.0	0.42	145
ELJEA220KF	22.0				18.0	0.65	115
ELJEA330KF	33.0				16.0	0.91	95
ELJEA470KF	47.0				13.0	1.30	80
ELJEA680KF	68.0		10.0	1.95	60		
ELJEA101KF	100.0		20	0.796	8.0	3.12	50
ELJEA151KF	150.0				7.0	4.03	45
ELJEA221KF	220.0				5.0	7.15	35
ELJEA331KF	330.0				4.0	9.23	30

*1 : Self Resonant Frequency *2 : DC Resistance

Looking for pricing, stock, or lifecycle information?

Click below to explore more details on WIN SOURCE:

-  [View ELJ-NK22NAF](#) on WIN SOURCE
-  [Panasonic](#) Information

Optimize Your Supply Chain with WIN SOURCE Solutions

-  Global Sourcing Solution
-  Obsolete Management
-  Cost Control Management
-  Shortage Management
-  Alternative Solution
-  Excess Inventory Management