



**THE DATASHEET OF
E-L6219R013TR**



Stepper motor driver

Features

- Able to drive both windings of bipolar stepper motor
- Output current up to 500 mA each winding
- Wide voltage range 4.5 V to 10 V
- Half-step, full-step and microstepping mode
- Built-in protection diodes
- Internal pwm current control
- Low output saturation voltage
- Designed for unstabilized motor supply voltage
- Internal thermal shutdown

Description

The L6219R is a bipolar monolithic integrated circuits intended to control and drive both winding of a bipolar stepper motor or bidirectionally control two DC motors. The L6219R with a few external components form a complete control and drive circuit for LS-TTL or microprocessor controlled stepper motor system. The power stage is a dual full bridge capable of sustaining 10 V and including four diodes for current recirculation.

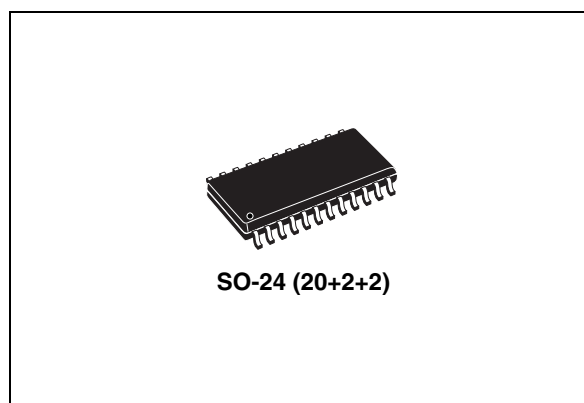

A cross conduction protection is provided to avoid simultaneous cross conduction during switching current direction.

An internal pulse-width-modulation (PWM) controls the output current to 500mA with peak start-up current up to 1 A. Wide range of current control from 500 mA (each bridge) is permitted by means of two logic inputs and an external voltage reference. A phase input to each bridge determines the load current direction. A thermal protection circuitry disables the outputs if the chip temperature exceeds safe operating limits.

Table 1. Device summary

Part number	Package	Packing
L6219R	SO-24	Tube
L6219R013TR	SO-24	Tape & reel
E-L6219R ⁽¹⁾	SO-24	Tube
E-L6219R013TR ⁽¹⁾	SO-24	Tape & reel

1. Lead free package (ECOPACK®) see [Chapter 5](#).

Table of contents

1	Block diagram and pins description	5
2	Electrical specifications	7
2.1	Absolute maximum ratings	7
2.2	Thermal data	7
2.3	Electrical characteristics	8
3	Functional description	10
3.1	Input logic (I0 and I1)	10
3.2	Phase	10
3.3	Current sensor	10
3.4	Single-pulse generator	11
3.5	Output stage	11
3.6	VS, VSS, VRef	11
4	Application informations	12
4.1	Electrical characteristics curves	13
5	Package informations	14
6	Revision history	15

List of tables

Table 1.	Device summary	1
Table 2.	Pin description	6
Table 3.	Absolute maximum ratings	7
Table 4.	Thermal data	7
Table 5.	Electrical characteristics	8
Table 6.	Input logic current level	10
Table 7.	Document revision history	15

List of figures

Figure 1.	Block diagram	5
Figure 2.	Pin connection (top view)	5
Figure 3.	Windings of a bipolar stepper motor	9
Figure 4.	Principle operating sequence	11
Figure 5.	Typical application circuit.	12
Figure 6.	Maximum output current vs. supply voltage (DAC=100%)	13
Figure 7.	Maximum reference voltages vs. supply voltage	13
Figure 8.	Maximum output current vs. reference voltage (DAC=100%)	13
Figure 9.	SO-24 mechanical data and package dimensions	14

1 Block diagram and pins description

Figure 1. Block diagram

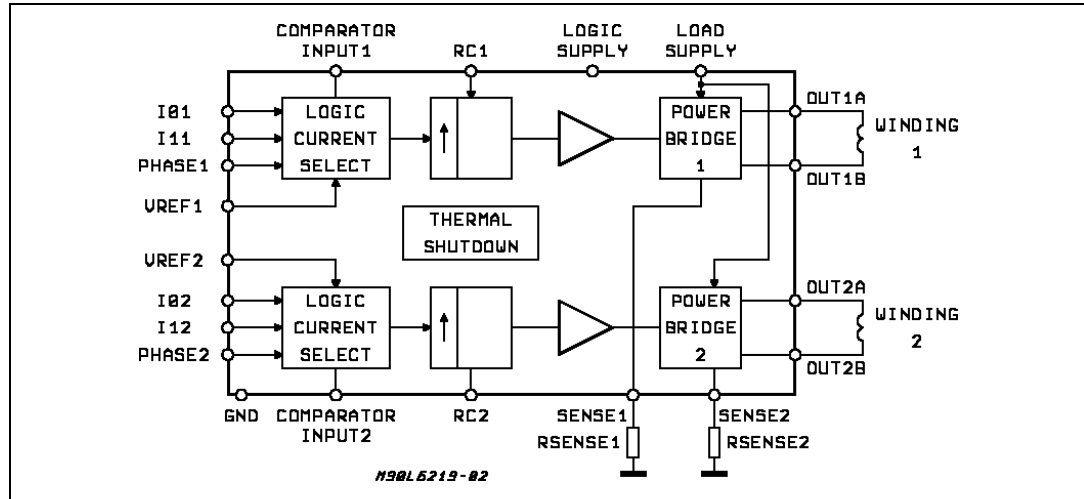

Figure 2. Pin connection (top view)

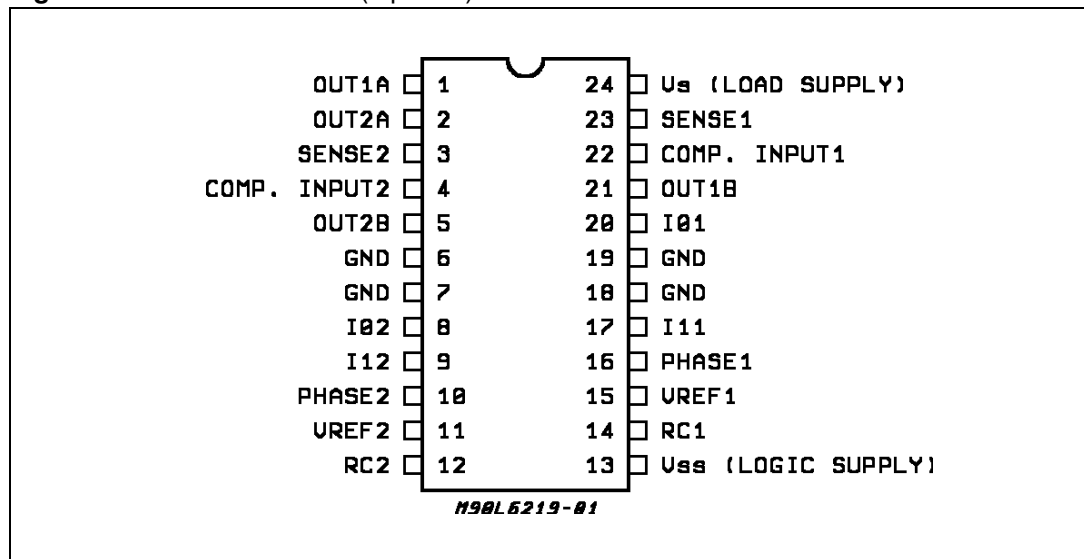

Table 2. Pin description

Pin #	Name	Description
1,2	Output A	See pins 5,21
3,23	Sense resistor	Connection to lower emitters of output stage for insertion of current sense resistor
4,22	Comparator input	Input connected to the comparators. The voltage across the sense resistor is feedback to this input through the low pass filter RC CC. The higher power transistors are disabled when the sense voltage exceeds the reference voltage of the selected comparator. When this occurs the current decays for a time set by RT CT (toff = 1.1 RT CT). See Figure 4
5,21	Output B	Output connection. The output stage is a H bridge formed by four transistors and four diodes suitable for switching applications
6,19	Ground	See pins 7,18
7,18	Ground	Ground connection. With pins 6 and 19 also conducts heat from die to printed circuit copper
8,20	Input 0	See input 1 (pins 9,17)
9,17	Input 1	These pins and pins 8,20 (input 0) are logic inputs which select the outputs of the comparators to set the current level. Current also depends on the sensing resistor and reference voltage. See functional description
10,16	Phase	This TTL-compatible logic inputs sets the direction of current flow through the load. a high level causes current to flow from output a (source) to output B (sink). A schmitt trigger on this input provides good noise immunity and a delay circuit prevents output stage short circuits during switching
11,15	Reference voltage	A voltage applied to this pin sets the reference voltage of the comparators, this determining the output current (also thus depending on Rs and the two inputs input 0 and input 1)
12,14	RC	A parallel RC network connected to this pin sets the OFF time of the higher power transistors. The pulse generator is a monostable triggered by the output of the comparators (toff = 1.1 RT CT)
13	Vss - Logic supply	Supply voltage input for logic circuitry
24	Vs - Load supply	Supply voltage input for the output stages

Note: ESD on GND, Vs, Vss, OUT 1 A and OUT 2 A is guaranteed up to 1.5 KV (human body model, 1500 W, 100 pF).

2 Electrical specifications

2.1 Absolute maximum ratings

Table 3. Absolute maximum ratings

Symbol	Parameter	Value	Unit
V_S	Supply voltage	30	V
I_o	Output current (peak)	± 1	A
I_o	Output current (continuous)	± 0.5	A
V_{SS}	Logic supply voltage	7	V
V_{IN}	Logic input voltage range	-0.3 to V_{SS}	V
V_{sense}	Sense output voltage	1.5	V
T_J	Junction temperature	+150	°C
T_{op}	Operating temperature range	-20 to +85	°C
T_{stg}	Storage temperature range	-55 to +150	°C

2.2 Thermal data

Table 4. Thermal data

Symbol	Description	Value	Unit
$R_{thj-case}$	Thermal resistance junction-case	Max. 18	°C/W
$R_{thj-amb}$	Thermal resistance junction-ambient	Max. 75 ⁽¹⁾	°C/W

1. With minimized copper area.

2.3 Electrical characteristics

Table 5. Electrical characteristics

($T_j = 25\text{ }^\circ\text{C}$, $V_S = 4.5\text{ V}$, $V_{SS} = 4.75\text{ V to } 5.25\text{ V}$, $V_{REF} = 2\text{ V}$, unless otherwise specified)
See [Figure 5](#).

Symbol	Parameter	Test Condition	Min.	Typ.	Max.	Unit
OUTPUT DRIVERS (OUT_A or OUT_B)						
V_S	Motor supply range		4.5		10	V
I_{CEX}	Output leakage current	$V_S = 30\text{ V}$, $V_{OUT} = V_S$, $V_S = 30\text{ V}$, $V_{OUT} = 0$	- -50	<1 <-1	50	μA μA
$V_{CE(sat)}$	Output saturation voltage	Sink driver, $I_{OUT} = +300\text{ mA}$	-	0.3	0.6	V
		Sink driver, $I_{OUT} = +500\text{ mA}$	-	0.7	1	V
		Source driver, $I_{OUT} = -300\text{ mA}$	-	1.1	1.4	V
		Source driver, $I_{OUT} = -500\text{ mA}$	-	1.3	1.6	V
V_F	Clamp diode forward voltage	Sink diode		1	1.5	V
		Source diode $I_F = 500\text{ mA}$		1	1.5	V
$I_{S(on)}$	Driver supply current	Both bridges ON, no load $V_S = 10\text{ V}$	-	8	15	mA
$I_{S(off)}$	Driver supply current	Both bridges OFF, $V_S = 10\text{ V}$	-	6	10	mA
CONTROL LOGIC						
$V_{IN(H)}$	Input voltage	All inputs	2.4	-	-	V
$V_{IN(L)}$	Input voltage	All inputs	-	-	0.8	V
$I_{IN(H)}$	Input current	$V_{IN} = 2.4\text{ V}$	-	<1	20	μA
$I_{IN(L)}$	Input current	$V_{IN} = 0.84\text{ V}$	-	-3	-200	μA
V_{REF}	Reference voltage	Operating ⁽¹⁾ ⁽²⁾	1.5	-	2	V
$I_{SS(ON)}$	Total logic supply current	$I_o = I_1 = 0.8\text{ V}$, no load	-	44	60	mA
$I_{SS(OFF)}$	Total logic supply current	$I_o = I_1 = 2.4\text{ V}$, no load	-	10	14	mA
COMPARATORS						
V_{REF}/V_{sense}	Current limit threshold (at trip point)	$I_o = I_1 = 0.8\text{ V}$	9.5	10	10.5	-
		$I_o = 2.4\text{ V}$, $I_1 = 0.8\text{ V}$	13.5	15	16.5	-
		$I_o = 0.8\text{ V}$, $I_1 = 2.4\text{ V}$	25.5	30	34.5	-
t_{off}	Cutoff time	$R_t = 56\text{ K}\Omega$, $C_t = 820\text{ pF}$	-	50		μs
t_d	Turn off delay	see Figure 1	-	1		μs
PROTECTION						
T_J	Thermal shutdown temperature		-	170	-	$^\circ\text{C}$

1. The maximum reference voltage accepted by the device depends from the supply voltage V_S (see [Figure 7](#)).
2. To reduce the switching losses the base bias of the bridge's low side NPN transistor is proportional to the DAC output, then the output current driving capability is also proportional to the DAC output voltage (see [Figure 6](#) and [Figure 8](#) for DAC=100%, it is proportional for lower percentages).

Figure 3. Windings of a bipolar stepper motor

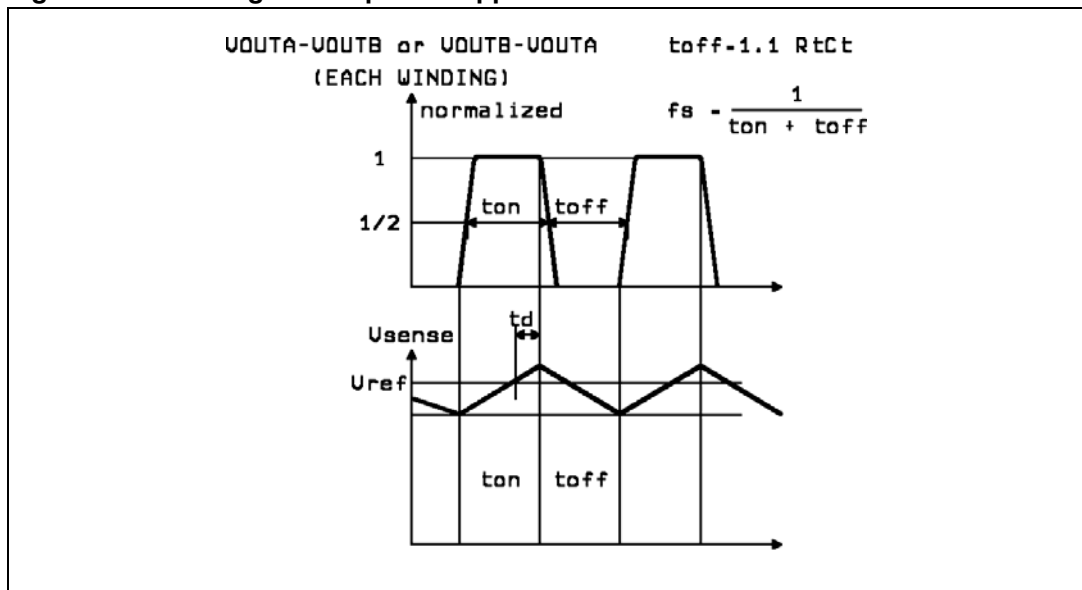

3 Functional description

The circuit is intended to drive both windings of a bipolar stepper motor.

The peak current control is generated through switch mode regulation. There is a choice of three different current levels with the two logic inputs I_{01} - I_{11} for winding 1 and I_{02} - I_{12} for winding 2.

The current can also be switched off completely

3.1 Input logic (I_0 and I_1)

The current level in the motor winding is selected with these inputs. (See [Figure 4](#))

If any of the logic inputs is left open, the circuit will treat it as a high level input.

Table 6. Input logic current level

I_0	I_1	Current level
H	H	No current
L	H	Low current $1/3 I_0$ max
H	L	Medium current $2/3 I_0$ max
L	L	Maximum current I_0 max

3.2 Phase

This input determines the direction of current flow in the windings, depending on the motor connections. The signal is fed through a schmidt-trigger for noise immunity, and through a time delay in order to guarantee that no short-circuit occurs in the output stage during phase-shift. High level on the phase input causes the motor current flow from out A through the winding to out B

3.3 Current sensor

This part contains a current sensing resistor (R_S), a low pass filter (R_C , C_C) and three comparators. Only one comparator is active at a time. It is activated by the input logic according to the current level chosen with signals I_0 and I_1 . The motor current flows through the sensing resistor R_S . When the current has increased so that the voltage across R_S becomes higher than the reference voltage on the other comparator input, the comparator goes high, which triggers the pulse generator.

The max peak current I_{max} can be defined by:

$$I_{max} = \frac{V_{ref}}{10R_S}$$

See figures [Figure 3](#), [4](#) and [5](#) for maximum allowable output current and reference voltage versus V_S supply.

3.4 Single-pulse generator

The pulse generator is a monostable triggered on the positive going edge of the comparator output. The monostable output is high during the pulse time, t_{off} , which is determined by the time components R_t and C_t .

$$t_{off} = 1.1 \cdot R_t C_t$$

The single pulse switches off the power feed to the motor winding, causing the winding current to decrease during t_{off} . If a new trigger signal should occur during t_{off} , it is ignored.

3.5 Output stage

The output stage contains four darlington transistors (source drivers) four saturated transistors (sink drivers) and eight diodes, connected in two H bridge.

Figure 4. Principle operating sequence

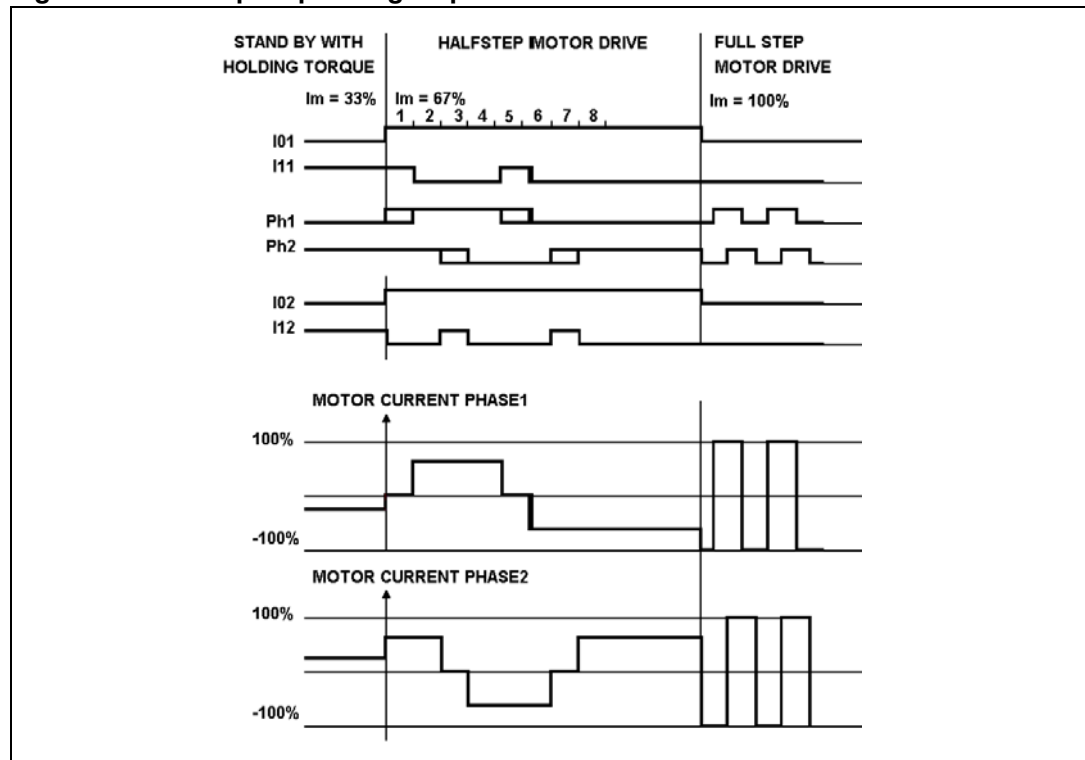

The source transistors are used to switch the power supplied to the motor winding, thus driving a constant current through the winding. It should be noted however, that is not permitted to short circuit the outputs.

Internal circuitry is added in order to increase the accuracy of the motor current particularly with low current levels.

3.6 V_S , V_{SS} , V_{Ref}

The circuit will stand any order of turn-on or turn-off the supply voltages V_S and V_{SS} . Normal dV/dt values are then assumed.

Preferably, V_{Ref} should be tracking V_{SS} during power-on and power-off if V_S is established.

4 Application informations

Some stepper motors are not designed for continuous operation at maximum current. As the circuit drives a constant current through the motor, its temperature might increase exceedingly both at low and high speed operation. Also, some stepper motors have such high core losses that they are not suited for switch mode current regulation.

Unused inputs should be connected to proper voltage levels in order to get the highest noise immunity. As the circuit operates with switch mode current regulation, interference generation problems might arise in some applications. A good measure might then be to decouple the circuit with a 100 nF capacitor, located near the package between power line and ground. The ground lead between R_s , and circuit GND should be kept as short as possible. A typical application circuit is shown in [Figure 5](#). Note that C_t must be NPO type or similar else. To sense the winding current, paralleled metal film resistors are recommended (R_s)

Figure 5. Typical application circuit.

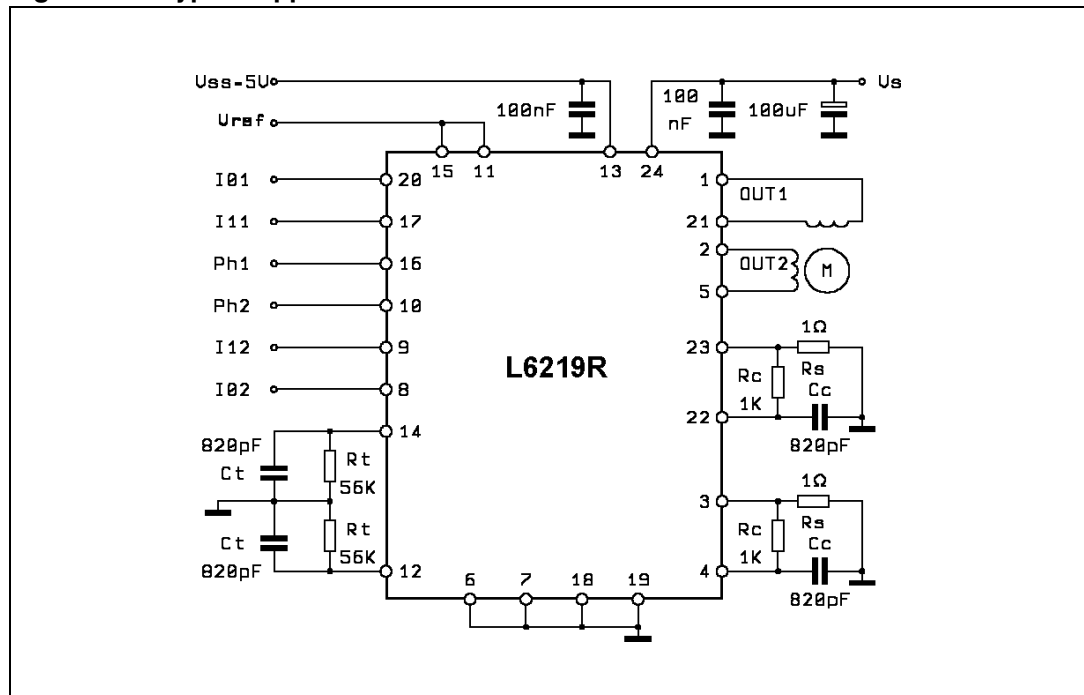

4.1 Electrical characteristics curves

Figure 6. Maximum output current vs. supply voltage (DAC=100%)

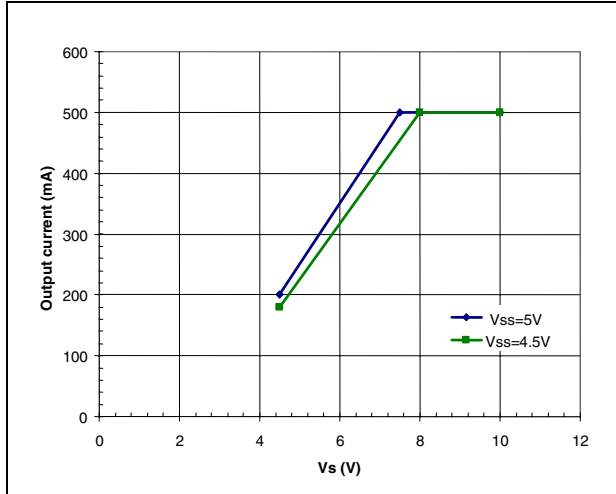

Figure 7. Maximum reference voltages vs. supply voltage

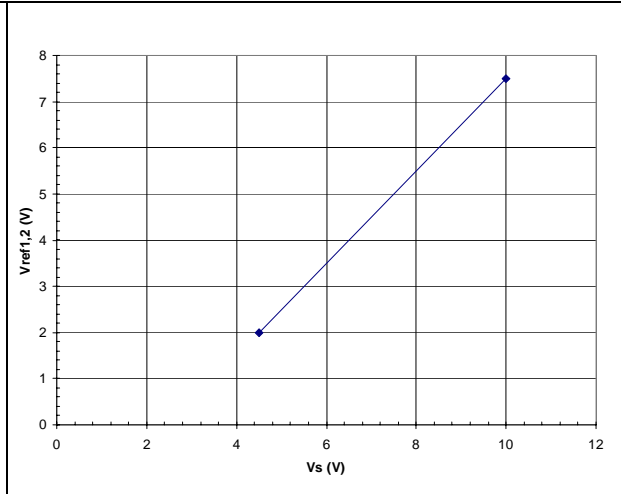
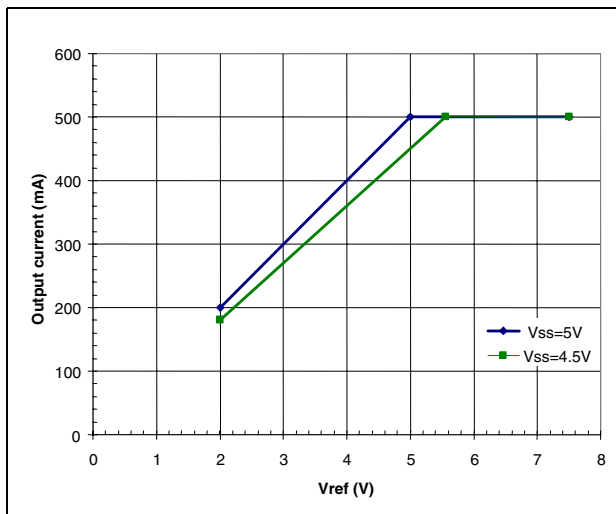

Figure 8. Maximum output current vs. reference voltage (DAC=100%)



5 Package informations

In order to meet environmental requirements, ST offers these devices in ECOPACK® packages. These packages have a Lead-free second level interconnect. The category of second Level Interconnect is marked on the package and on the inner box label, in compliance with JEDEC Standard JESD97. The maximum ratings related to soldering conditions are also marked on the inner box label. ECOPACK is an ST trademark.

ECOPACK specifications are available at: www.st.com.

Figure 9. SO-24 mechanical data and package dimensions

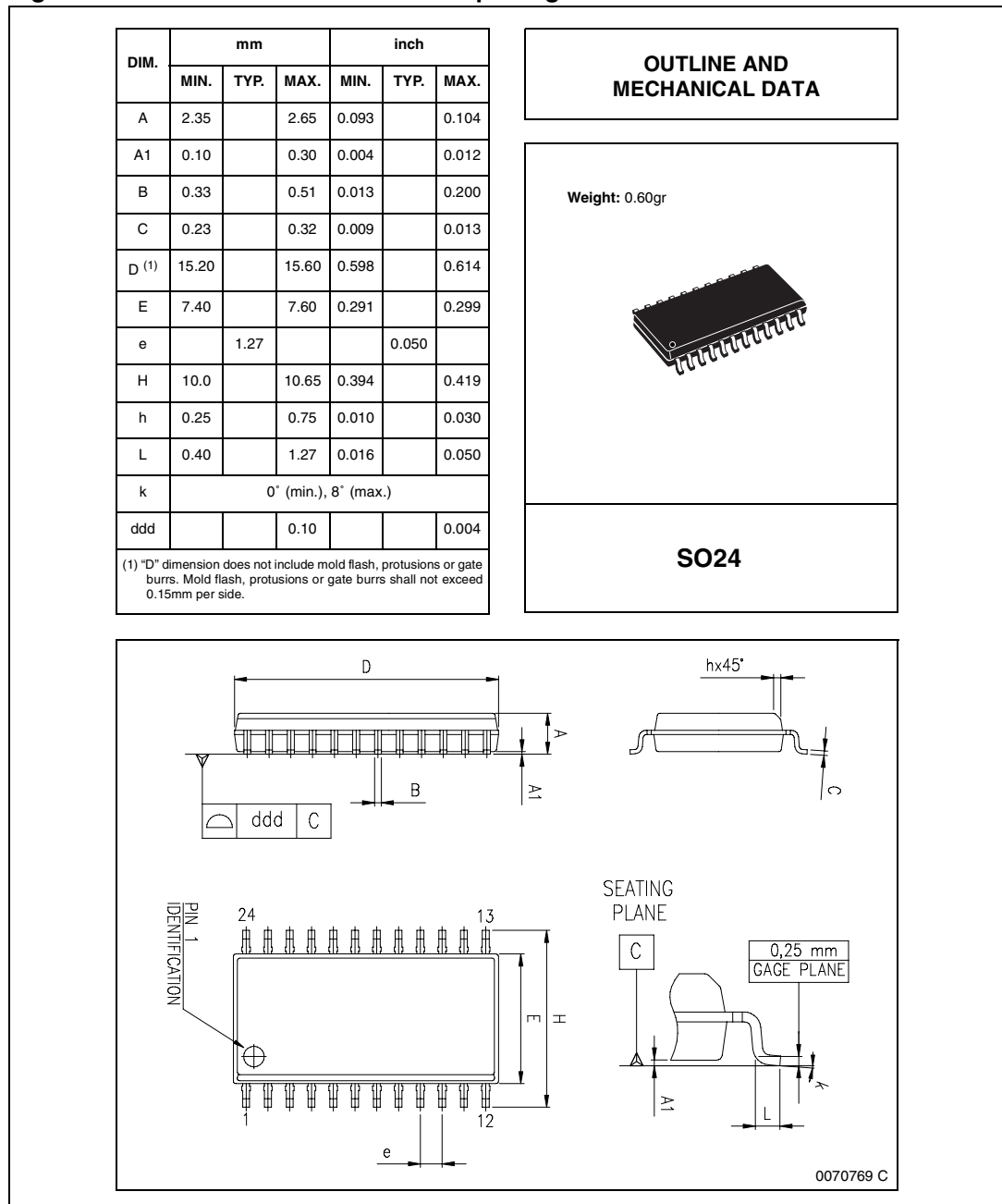

6 Revision history

Table 7. Document revision history

Date	Revision	Changes
09-Jan-2003	1	First Issue
06-May-2005	2	Modified Table 2 on page 6 .
22-Jun-2006	3	Changed look and fill. Changed value of the Output Current (continuous) in Table 3 . Changed the curve diagrams of the Figure 6 and 7 .
05-Sep-2008	4	Added note 1 and 2 in Table 5 on page 8 .

Please Read Carefully:

Information in this document is provided solely in connection with ST products. STMicroelectronics NV and its subsidiaries ("ST") reserve the right to make changes, corrections, modifications or improvements, to this document, and the products and services described herein at any time, without notice.

All ST products are sold pursuant to ST's terms and conditions of sale.

Purchasers are solely responsible for the choice, selection and use of the ST products and services described herein, and ST assumes no liability whatsoever relating to the choice, selection or use of the ST products and services described herein.

No license, express or implied, by estoppel or otherwise, to any intellectual property rights is granted under this document. If any part of this document refers to any third party products or services it shall not be deemed a license grant by ST for the use of such third party products or services, or any intellectual property contained therein or considered as a warranty covering the use in any manner whatsoever of such third party products or services or any intellectual property contained therein.

UNLESS OTHERWISE SET FORTH IN ST'S TERMS AND CONDITIONS OF SALE ST DISCLAIMS ANY EXPRESS OR IMPLIED WARRANTY WITH RESPECT TO THE USE AND/OR SALE OF ST PRODUCTS INCLUDING WITHOUT LIMITATION IMPLIED WARRANTIES OF MERCHANTABILITY, FITNESS FOR A PARTICULAR PURPOSE (AND THEIR EQUIVALENTS UNDER THE LAWS OF ANY JURISDICTION), OR INFRINGEMENT OF ANY PATENT, COPYRIGHT OR OTHER INTELLECTUAL PROPERTY RIGHT.

UNLESS EXPRESSLY APPROVED IN WRITING BY AN AUTHORIZED REPRESENTATIVE OF ST, ST PRODUCTS ARE NOT DESIGNED, AUTHORIZED OR WARRANTED FOR USE IN MILITARY, AIR CRAFT, SPACE, LIFE SAVING, OR LIFE SUSTAINING APPLICATIONS, NOR IN PRODUCTS OR SYSTEMS, WHERE FAILURE OR MALFUNCTION MAY RESULT IN PERSONAL INJURY, DEATH, OR SEVERE PROPERTY OR ENVIRONMENTAL DAMAGE.

Resale of ST products with provisions different from the statements and/or technical features set forth in this document shall immediately void any warranty granted by ST for the ST product or service described herein and shall not create or extend in any manner whatsoever, any liability of ST.

ST and the ST logo are trademarks or registered trademarks of ST in various countries.

Information in this document supersedes and replaces all information previously supplied.

The ST logo is a registered trademark of STMicroelectronics. All other names are the property of their respective owners.

© 2008 STMicroelectronics - All rights reserved



STMicroelectronics group of companies

Australia - Belgium - Brazil - Canada - China - Czech Republic - Finland - France - Germany - Hong Kong - India - Israel - Italy - Japan - Malaysia - Malta - Morocco - Singapore - Spain - Sweden - Switzerland - United Kingdom - United States of America

www.st.com

Looking for pricing, stock, or lifecycle information?

Click below to explore more details on WIN SOURCE:

-  [View E-L6219R013TR](#) on WIN SOURCE
-  [STMicroelectronics](#) Information

Optimize Your Supply Chain with WIN SOURCE Solutions

-  Global Sourcing Solution
-  Obsolete Management
-  Cost Control Management
-  Shortage Management
-  Alternative Solution
-  Excess Inventory Management