



**THE DATASHEET OF
EELXT905PC.C2**





LXT905

Universal 10BASE-T Transceiver with 3.3V Support

Datasheet

The LXT905 Universal 10BASE-T Transceiver is designed for IEEE 802.3 physical layer applications. It provides, in a single CMOS device, all the active circuitry for interfacing most standard IEEE 802.3 controllers to 10BASE-T media.

The LXT905 functions include Manchester encoding/decoding, receiver squelch and transmit pulse shaping, jabber, link integrity testing, and reversed polarity detection/correction. The LXT905 drives the 10BASE-T twisted-pair cable, with only a simple isolation transformer, using a single 3.3V or 5V power supply. Integrated filters simplify the design work required for FCC-compliant EMI performance.

The LXT905 is part of the Intel Carrier Class Ethernet family of products. The LXT905 Universal Transceiver offers 10BASE-T connectivity solutions that support operations over an extended temperature range, while providing features that increase reliability. The device has an operational lifetime of at least ten years, with less than 100 failures per billion hours, and will be available a minimum of five years from the introduction of the product.

Intel Carrier Class Ethernet products are ideal for applications where equipment must function reliably under environmentally controlled conditions, such as base stations, telecom/network switches, factory floor equipment, and industrial computers.

Applications

- Access devices (DSL, Cable Modems, and Set-top Boxes)
- Routers/Bridges/Switches/Hubs
- Telecom Backplane
- USB to Ethernet Converters

Product Features

- Transparent 3.3V or 5V operation
- Integrated filters – Simplifies FCC compliance
- Integrated Manchester encoder/decoder
- 10BASE-T compliant transceiver
- Automatic polarity correction
- SQE enable/disable
- Four LED drivers
- Full-duplex capability
- Power-down mode with tri-state
- Available in 28-pin PLCC and 32-pin LQFP packages
- Commercial Temperature Range (0 to +70°C)
- Extended Temperature Range (-40 to +85°C)



Information in this document is provided in connection with Intel® products. No license, express or implied, by estoppel or otherwise, to any intellectual property rights is granted by this document. Except as provided in Intel's Terms and Conditions of Sale for such products, Intel assumes no liability whatsoever, and Intel disclaims any express or implied warranty, relating to sale and/or use of Intel products including liability or warranties relating to fitness for a particular purpose, merchantability, or infringement of any patent, copyright or other intellectual property right. Intel products are not intended for use in medical, life saving, or life sustaining applications.

Intel may make changes to specifications and product descriptions at any time, without notice.

Designers must not rely on the absence or characteristics of any features or instructions marked "reserved" or "undefined." Intel reserves these for future definition and shall have no responsibility whatsoever for conflicts or incompatibilities arising from future changes to them.

The LXT905 may contain design defects or errors known as errata which may cause the product to deviate from published specifications. Current characterized errata are available on request.

Contact your local Intel sales office or your distributor to obtain the latest specifications and before placing your product order.

Copies of documents which have an ordering number and are referenced in this document, or other Intel literature may be obtained by calling 1-800-548-4725 or by visiting Intel's website at <http://www.intel.com>.

Copyright © Intel Corporation, 2001

*Third-party brands and names are the property of their respective owners.

Contents

1.0	Pin Assignments and Signal Descriptions	8
2.0	Functional Description	10
2.1	Introduction.....	10
2.2	Controller Compatibility Modes	11
2.3	Transmit Function.....	11
2.4	Jabber Control Function	12
2.5	SQE Function	13
2.6	Receive Function.....	13
2.7	Polarity Reverse Function	14
2.8	Collision Detection Function.....	14
2.9	Loopback Functions	15
2.9.1	Internal Loopback.....	15
2.9.2	External Loopback/Full Duplex.....	15
2.10	Link Integrity Test Function	15
3.0	Application Information	17
3.1	Introduction.....	17
3.1.1	Termination Circuitry	17
3.1.2	Twisted-Pair Interface	17
3.1.3	RBIAS Pin	17
3.1.4	Crystal Information	17
3.1.5	Magnetic Information	18
3.2	Typical 10BASE-T Application	18
3.3	Dual Network Support - 10BASE-T and Token Ring.....	19
3.4	Simple 10BASE-T Connection	21
4.0	Test Specifications	22
4.1	Timing Diagrams for Mode 1 (MD1 = Low, MD0 = Low) Figures 11 - 14	26
4.2	Timing Diagrams for Mode 2 (MD1 = Low, MD0 = High) Figures 15 - 18	28
4.3	Timing Diagrams for Mode 3 (MD1 = High, MD0 = Low) Figures 19 - 22	30
4.4	Timing Diagrams for Mode 4 (MD1 = High, MD0 = High) Figures 23 - 26	32
5.0	Mechanical Specifications	34
A	Ordering Information	37

Figures

1	LXT905 Block Diagram	7
2	LXT905 Pin Assignments.....	8
3	LXT905 TPO Output Waveform	10
4	Jabber Control Function.....	12
5	SQE Function.....	13
6	Collision Detection Function.....	14
7	Link Integrity Test Function	16

8	Intel Controller Application (Mode 2).....	19
9	LXT905/380C26 Interface for Dual 10BASE-T and Token Ring Support (Mode 4).....	20
10	LXT905/MC68EN360 Interface for Full-Duplex 10BASE-T (Mode 1)	21
11	Mode 1 RCLK/Start-of-Frame Timing	26
12	Mode 1 RCLK/End-of-Frame Timing	26
13	Mode 1 Transmit Timing	27
14	Mode 1 COL Output Timing	27
15	Mode 2 RCLK/Start-of-Frame	28
16	Mode 2 RCLK/End-of-Frame Timing	28
17	Mode 2 Transmit Timing	29
18	Mode 2 COL Output Timing	29
19	Mode 3 RCLK/Start-of-Frame Timing	30
20	Mode 3 RCLK/End-of-Frame Timing.....	30
21	Mode 3 Transmit Timing	31
22	Mode 3 COL Output Timing	31
23	Mode 4 RCLK/Start-of-Frame Timing	32
24	Mode 4 RCLK/End-of-Frame Timing	32
25	Mode 4 Transmit Timing	33
26	Mode 4 COL Output Timing	33
27	LXT905PC Package Specifications	34
28	LXT905LC Package Specifications	35
29	Ordering Information - Sample.....	37

Tables

1	LXT905 Signal Descriptions.....	9
2	Controller Compatibility Mode Options.....	11
3	Loopback Modes.....	15
4	Suitable Crystals	17
5	Absolute Maximum Values.....	22
6	Recommended Operating Conditions	22
7	I/O Electrical Characteristics	22
8	TP Electrical Characteristics	23
9	Switching Characteristics	23
10	RCLK/Start-of-Frame Timing	24
11	RCLK/End-of-Frame Timing.....	24
12	Transmit Timing	24
13	Miscellaneous Timing.....	25
14	PLASTIC LEADED CHIP CARRIER	34
15	QUAD FLAT PACKAGE.....	35
16	Product Information.....	37

Revision History

Date	Revision	Page #	Description
June 2001	002	1	New information under "Applications".
		1	Added new carrier class information (paragraphs 3 and 4).
		19	Added +5V to Line Status, Figure 8.
		20	Added +5V to Line Status, Figure 9.
		22	Added second paragraph under Test Specifications "Note" regarding Quality and Reliability issues.
		22	Deleted Ambient operating temperatures from Table 5.
		34	Added new diagram and table for LXT905PC/PE mechanical specifications.

Figure 1. LXT905 Block Diagram

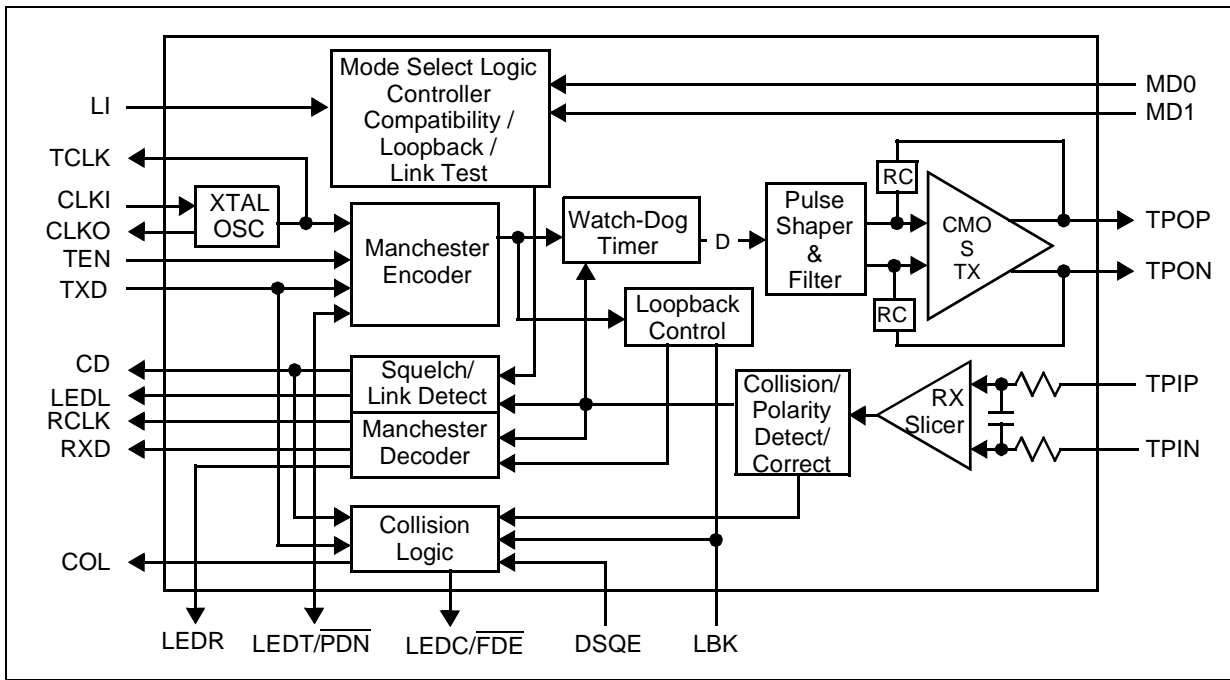

1.0 Pin Assignments and Signal Descriptions

Figure 2. LXT905 Pin Assignments

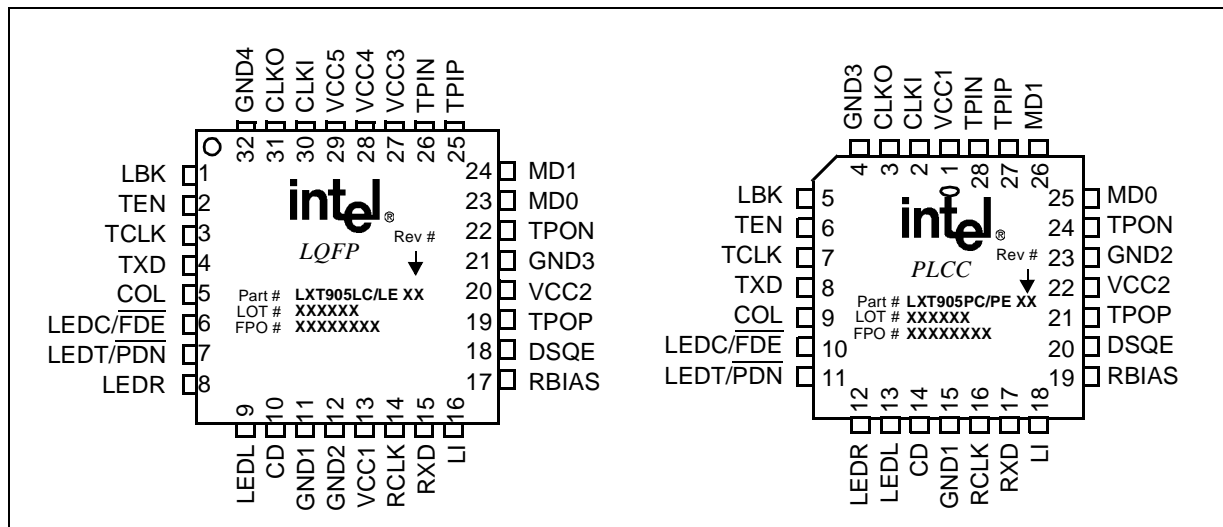

Table 1. LXT905 Signal Descriptions

LQFP Pin #	PLCC Pin #	Symbol	I/O	Description
13 20 27 28 29	1 22 – – –	VCC1 VCC2 VCC3 VCC4 VCC5	– – – – –	Power Inputs 1 thru 5. Power supply inputs of 3.3V or 5V.
30 31	2 3	CLKI CLKO	I O	Crystal Oscillator. A 20 MHz crystal must be connected across these pins, or a 20 MHz clock applied at CLKI, with CLKO left open.
11 12 21 32	15 23 4 –	GND1 GND2 GND3 GND4	– – – –	Ground.
1	5	LBK	I	Loopback. When High, forces internal loopback. Disables collision and the transmission of both data and link pulses. Pulled Low internally ¹ .
2	6	TEN	I	Transmit Enable. Enables data transmission and starts the Watch-Dog Timer (WDT). Synchronous to TCLK. Pulled Low internally ¹ .
3	7	TCLK	O	Transmit Clock. A 10 MHz clock output. This clock signal should be directly connected to the transmit clock input of the controller.
4	8	TXD	I	Transmit Data. Input signal containing NRZ data to be transmitted on the network. TXD should be connected directly to the transmit data output of the controller. Pulled Low internally ¹ .
5	9	COL	O	Collision Signal. Output that drives the collision detect input of the controller.
6	10	LEDC/ FDE	O I	LED Collision or Full-Duplex Enable. LEDC is an open drain driver for the collision indicator pulls Low during collision. LED “on” (which is Low output) time is extended by approximately 100 ms. FDE enables full-duplex mode (external loopback) if tied Low externally. Pulled High internally ¹ .
7	11	LEDT/ PDN	O I	LED Transmit or Power Down. LEDT is an open drain driver for the transmit indicator. LED “on” (which is Low output) time is extended by approximately 100 ms. Output is pulled Low during transmit. ² If externally tied Low, the LXT905 goes to power down state (PDN). In power-down mode, all logic inputs and outputs are tristated.
8	12	LEDR	O	LED Receive. Open drain driver for the receive indicator LED. LED “on” (<i>i.e.</i> , Low output) time is extended by approximately 100 ms. Output is pulled Low during receive. Pulled High internally ¹ .
9	13	LEDL	O	LED Link. Open drain driver for link integrity indicator. Output is pulled Low during link test pass. Pulled High internally ¹ .
10	14	CD	O	Carrier Detect. An output for notifying the controller that activity exists on the network.
14	16	RCLK	O	Receive Clock. A recovered 10 MHz clock that is synchronous to the received data and connected to the controller receive clock input.
15	17	RXD	O	Receive Data. Output signal connected directly to the receive data input of the controller.

1. Externally pull-up or pull-down each pin separately using a 10k Ω , 1% termination resistor or tie directly to Vcc or ground.
2. Do not allow this pin to float. If unused, tie High.

Table 1. LXT905 Signal Descriptions (Continued)

LQFP Pin #	PLCC Pin #	Symbol	I/O	Description
16	18	LI	I	Link Enable. Controls link integrity test; enabled when LI is High, disabled when LI is Low.
17	19	RBIAS	I	Bias Circuitry. A 7.5 k Ω 1% resistor to ground at this pin controls operating circuit bias.
18	20	DSQE	I	SQE Disable. When DSQE is High, the SQE function is disabled. When DSQE is Low, the SQE function is enabled. SQE should be disabled for normal operation in Hub/Switch/Repeater applications. Pulled Low internally ¹ .
19 22	21 24	TPOP TPON	O O	Twisted-Pair Outputs. Differential outputs to the twisted-pair cable. The outputs are pre-equalized.
23 24	25 26	MDO MDI	I I	Mode Select 0 and 1. Mode select pins determine controller compatibility mode in accordance with Table 2. Pulled Low internally ¹ .
25 26	27 28	TPIP TPIN	I I	Twisted-Pair Inputs. A differential input pair from the twisted-pair cable. Receive filter is integrated on-chip. No external filters are required.

1. Externally pull-up or pull-down each pin separately using a 10k Ω , 1% termination resistor or tie directly to Vcc or ground.
2. Do not allow this pin to float. If unused, tie High.

2.0 Functional Description

2.1 Introduction

The LXT905 Universal 10BASE-T Transceiver performs the physical layer signaling (PLS) and Media Attachment Unit (MAU) functions, as defined by the IEEE 802.3 specification. It functions as an integrated PLS/MAU for use with 10BASE-T twisted-pair networks.

The LXT905 interfaces a back-end controller to a twisted-pair (TP) cable. The controller interface includes a transmit and receive clock and NRZ data channels, as well as mode control logic and signaling. The twisted-pair interface comprises two circuits: Twisted-Pair Input (TPI) and Twisted-Pair Output (TPO). In addition to the two basic interfaces, the LXT905 contains an internal crystal oscillator and four LED drivers for visual status reporting.

Functions are defined from the back-end controller side of the interface. The LXT905 Transmit function refers to data transmitted by the back-end to the twisted-pair network. The LXT905 Receive function refers to data received by the back-end from the twisted-pair network. The LXT905 performs all required functions defined by the IEEE 802.3 10BASE-T MAU specification, such as collision detection, link integrity testing, signal quality error messaging, jabber control, and loopback.

Figure 3. LXT905 TPO Output Waveform

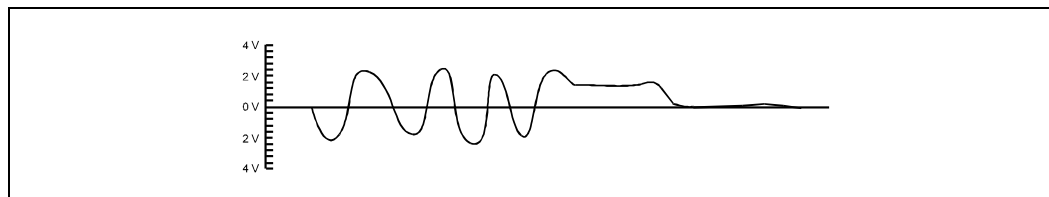

2.2 Controller Compatibility Modes

The LXT905 is compatible with most industry standard controllers, including devices produced by Advanced Micro Devices (AMD), Intel, Fujitsu, National Semiconductor, Seeq, Motorola, and Texas Instruments. Four different control signal timing and polarity schemes (Modes 1 through 4) are required to achieve this compatibility. Mode select pins MD0 and MD1 determine controller compatibility modes as listed in Table 2. Refer to the Test Specifications section for timing diagrams and parameters.

2.3 Transmit Function

The LXT905 receives NRZ data from the controller at the TXD input, as shown in the block diagram, and passes it through a Manchester encoder. The encoded data is then transferred to the twisted-pair network (TPO circuit). The advanced integrated pulse shaping and filtering network produces the output signal on TPON and TPOP, as shown in Figure 3 on page 10. The TPO output is pre-distorted and pre-filtered to meet the 10BASE-T jitter template. An internal, continuous resistor-capacitor filter is used to remove any high-frequency clocking noise from the pulse shaping circuitry. Integrated filters simplify the design work required for FCC compliant EMI performance. During idle periods, the LXT905 transmits link integrity test pulses on the TPO circuit (if LI is enabled and LBK is disabled).

Table 2. Controller Compatibility Mode Options

Controller Mode	MD1	MD0
Mode 1 - For Motorola MC68EN360 or compatible controllers (AMD AM7990)	Low	Low
Mode 2 - For Intel 82596 or compatible controllers ¹	Low	High
Mode 3 - For Fujitsu MB86950, MB86960 or compatible controllers (Seeq 8005) ²	High	Low
Mode 4 - For TI TMS380C26 or compatible controllers	High	High
1. Refer to Intel Application Note 51 (MAC Interface Design Guide for Intel Controllers) when designing with Intel controllers. 2. SEEQ controllers require inverters on CLKI, LBK, RCLK and COL.		

2.4 Jabber Control Function

Figure 4 is a state diagram of the LXT905 jabber control function. The LXT905 on-chip Watch-Dog Timer (WDT) prevents the DTE from locking into a continuous transmit mode. When a transmission exceeds the time limit, the WDT disables the transmit and loopback functions and activates the COL pin. Once the LXT905 is in the jabber state, the TXD circuit must remain idle for a period of 0.25 to 0.75 seconds before it exits the jabber state.

Figure 4. Jabber Control Function

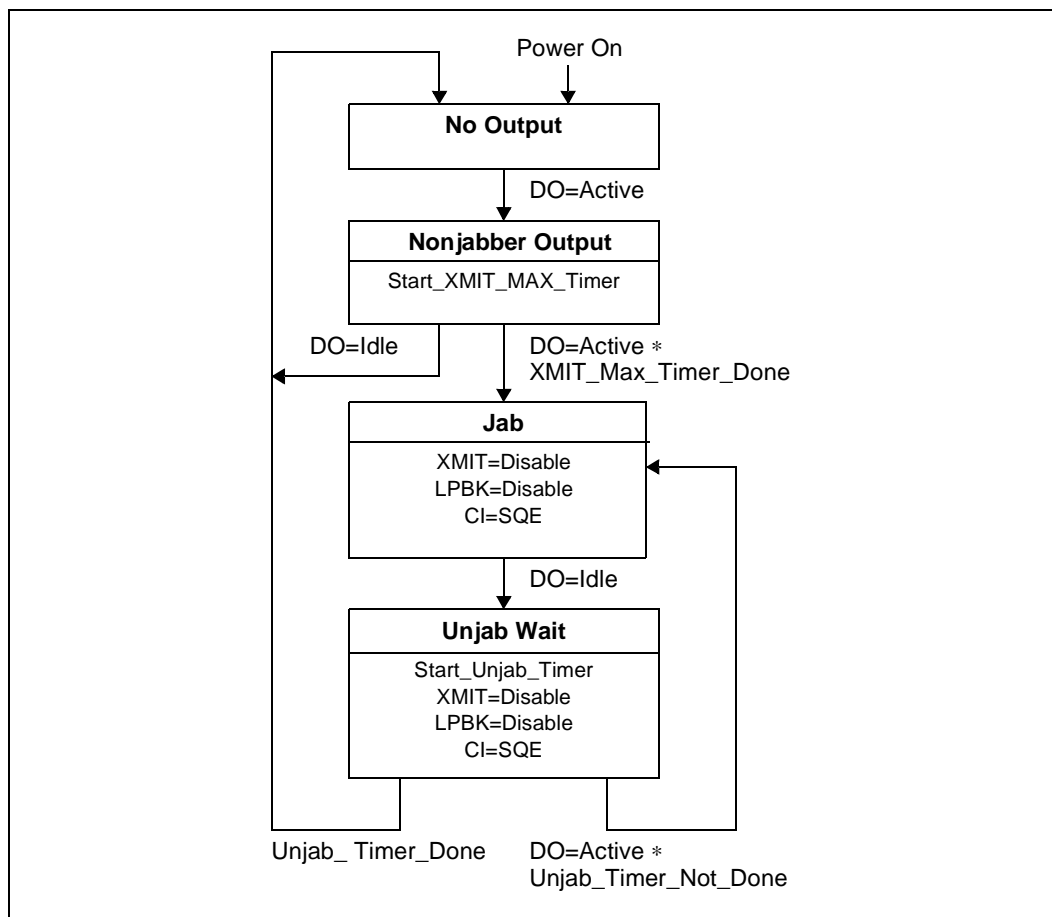

2.5 SQE Function

The LXT905 supports the Signal Quality Error (SQE) function as shown in Figure 5. After every successful transmission on the 10BASE-T network, the LXT905 transmits the SQE signal for $10 \text{ bit times (BT)} \pm 5\text{BT}$ on the COL pin of the device.

The SQE can be disabled for repeater/switch applications. When DSQE is set High, the SQE function is disabled. When DSQE is Low, the SQE function is enabled.

Figure 5. SQE Function

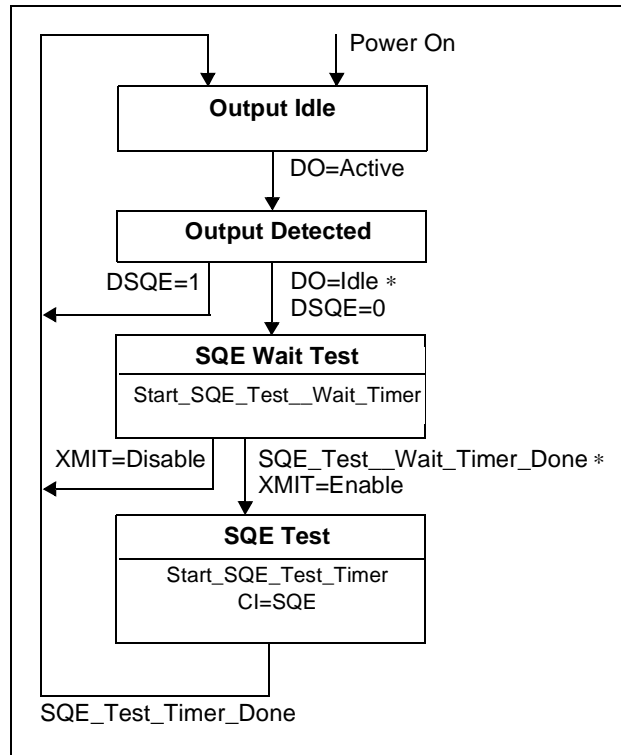

2.6 Receive Function

The LXT905 receive function acquires timing and data from the twisted-pair network (TPI circuit). Valid received signals are passed through the on-chip filters and Manchester decoder, then output as decoded NRZ data and receive timing on the RXD and RCLK pins, respectively.

An internal RC filter and an intelligent squelch function discriminate noise from link test pulses and valid data streams. The receive function is activated only by valid data streams above the squelch level with proper timing.

If the differential signal at the TPI circuit inputs falls below 85 percent of the threshold level (unsquelched) for 8 bit times (typical), the LXT905 receive function enters the idle state. The LXT905 automatically corrects reversed polarity on the TPI circuit.

2.7 Polarity Reverse Function

The LXT905 polarity reverse function uses both link pulses and end-of-frame data to determine polarity of the received signal. If Link Integrity testing is disabled, polarity detection is based only on received data. A reversed polarity condition is detected when eight consecutive opposite receive link pulses are detected without receipt of a link pulse of the expected polarity. Reversed polarity is also detected if four consecutive frames are received with a reversed start-of-idle. Whenever a correct polarity frame or a correct link pulse is received, these two counters are reset to zero. If the LXT905 enters the link fail state and no valid data or link pulses are received within 96 to 128 ms, the polarity is reset to the default non-flipped condition. Polarity correction is always enabled.

2.8 Collision Detection Function

A collision is defined as the simultaneous presence of valid signals on both the TPI circuit and the TPO circuit. The LXT905 reports collisions to the back-end via the COL pin. If the TPI circuit becomes active while there is activity on the TPO circuit, the TPI data is passed to the back-end over the RXD circuit, disabling normal loopback. Figure 6 is a state diagram of the LXT905 collision detection function.

Figure 6. Collision Detection Function

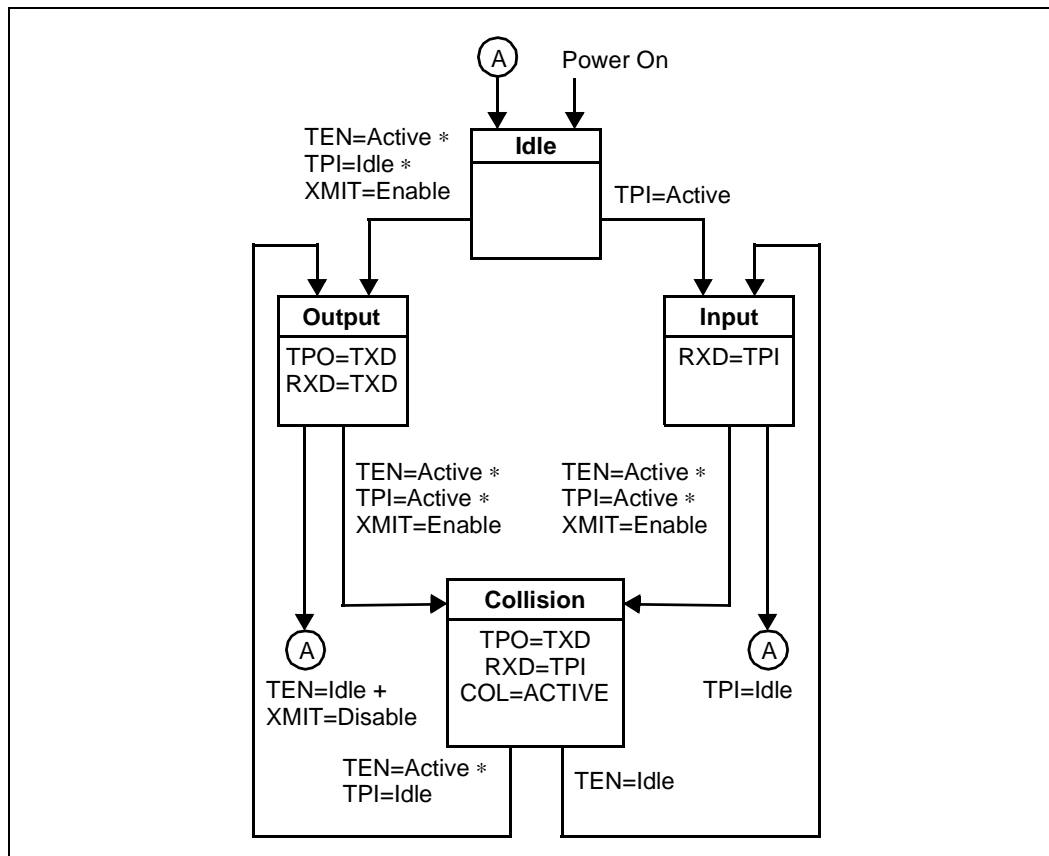

2.9 Loopback Functions

2.9.1 Internal Loopback

The LXT905 provides standard loopback mode as specified in the IEEE specification for the twisted-pair port, as well as a forced internal loopback mode. Loopback mode operates in conjunction with the transmit function. Data transmitted by the MAC is internally looped back within the LXT905 from the TXD pin through the Manchester encoder/decoder to the RXD pin and returned to the MAC.

Standard loopback mode is disabled when a data collision occurs, clearing the RXD circuit for the TPI data. Standard loopback is also disabled during link fail, jabber, and full-duplex states. Loopback is always enabled during forced internal loopback mode.

2.9.2 External Loopback/Full Duplex

The LXT905 also provides an external loopback test mode for system-level testing. When both LEDC/FDE and LBK are Low, the LXT905 enables external loopback and full-duplex mode. Internal loopback circuits, SQE, and collision detection are disabled. Refer to [Table 3](#) for a summary of loopback and duplex modes.

Table 3. Loopback Modes

Pin Settings		Mode Description
LBK	LEDC/ FDE	
Low	Low	Disable internal loopback. Enable external loopback test mode and full-duplex mode.
Low	High	Standard loopback mode (default). Data transmitted by the MAC is internally looped back and returned to the MAC except during collision. Standard loopback is disabled when a data collision occurs, clearing RXD for data on the twisted-pair port.
High	Low	Not Used.
High	High	Forced internal loopback. Transmit data is looped back on the receive data bus and the twisted-pair port is ignored.

2.10 Link Integrity Test Function

Figure 7 on page 16 is a state diagram of the LXT905 Link Integrity test function. The link integrity test is used to determine the status of the receive side twisted-pair cable. Link integrity testing is enabled when LI is tied High. When enabled, the receiver recognizes link integrity pulses which are transmitted in the absence of receive traffic. If no serial data stream or link integrity pulses are detected within 50~150 ms, the chip enters a link fail state and disables the transmit and normal loopback functions. The LXT905 ignores any link integrity pulse with interval less than 2~7 ms. The LXT905 remains in the link fail state until it detects either a serial data packet or two or more link integrity pulses.

Figure 7. Link Integrity Test Function

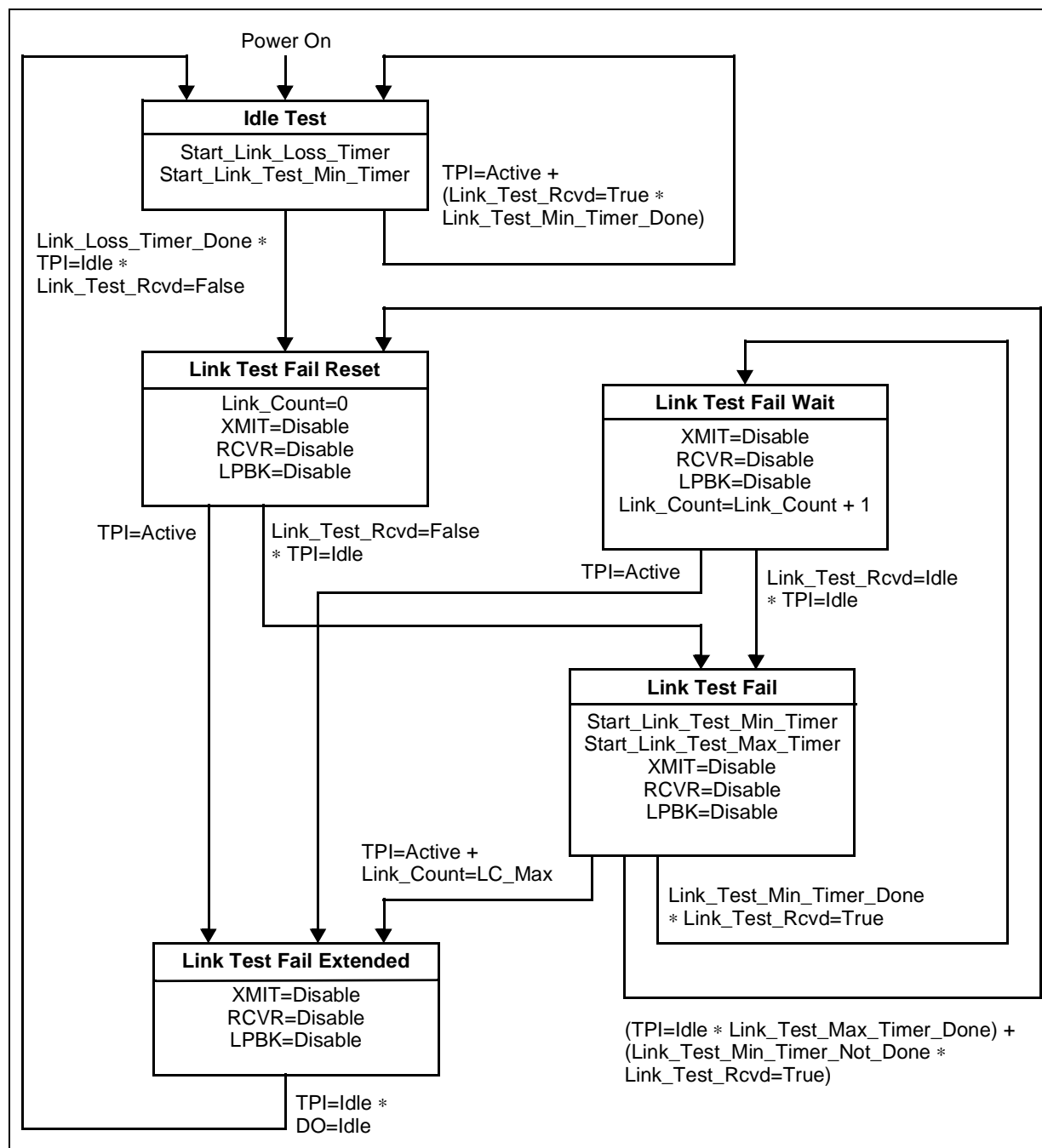

3.0 Application Information

3.1 Introduction

Figure 8 on page 19 through Figure 10 on page 21 show typical LXT905 applications. These diagrams group similar pins; they do not portray the actual chip pinout. The controller interface pins; Transmit Data (TXD), Transmit Clock (TCLK) Transmit Enable (TEN), Receive Data (RXD), Receive Clock (RCLK), Collision Signal (COL), and Carrier Detect (CD) pins are at the upper left of the diagram.

Power and ground pins are at the bottom of each diagram. VCC1 and VCC2 use a single power supply with decoupling capacitors installed between the power and ground busses. VCC may be powered by a 5V or 3.3V supply.

3.1.1 Termination Circuitry

Several I/O pins are pulled-up or pulled-down internally to keep the signals from floating. It is recommended to hard-wire these pins either High or Low. Externally pull-up pins (LEDT/ $\overline{\text{PDN}}$, LEDC/FDE, LEDR, LEDL) and pull-down pins (LBK, TEN, TXD, DSQE, MDO, MDI) separately using a 10k Ω , 1% resistor, or tie directly to VCC or ground.

3.1.2 Twisted-Pair Interface

The Twisted-Pair interface (TPOP/N and TPIP/N) is at the upper right of the diagram. The I/O pairs have impedance-matching resistors for 100 Ω UTP, but no external filters are required.

3.1.3 RBIAS Pin

The RBIAS pin sets the levels for the LXT905 output drivers. The LXT905 requires a 7.5k Ω , 1% resistor directly connected between the RBIAS pin and ground. This resistor should be located as close to the device as possible. Keep the traces as short as possible and isolated from all other high speed signals.

3.1.4 Crystal Information

Based on limited evaluation, Table 4 lists some suitable crystals. Designers should test and validate all crystals before committing to a specific component.

Table 4. Suitable Crystals

Manufacturer	Part Number
MTRON	MP-1
	MP-2

3.1.5 Magnetic Information

The LXT905 requires a 1:1 turns ratio for the receive transformer and a 1:2 turns ratio for the transmit transformer. [Application Note 073, Magnetic Manufacturers](#) (248991-001) lists transformers suitable for the applications described in this data sheet. Designers are advised to test and validate all magnetics before committing to a specific component.

3.2 Typical 10BASE-T Application

[Figure 8 on page 19](#) is a typical LXT905 application. The DTE is connected to a 10BASE-T network through the twisted-pair RJ-45 connector. With MD0 tied high and MD1 grounded, the LXT905 logic and framing are set to Mode 2 (compatible with Intel 82596 controllers*). Connect a 20 MHz system clock input at CLKI (leave CLKO open). The LI pin externally controls the link test function.

* Refer to Intel Application Note 51, MAC Interface Design Guide for Intel Controllers (249007-001) when designing with Intel controllers.

Figure 8. Intel Controller Application (Mode 2)

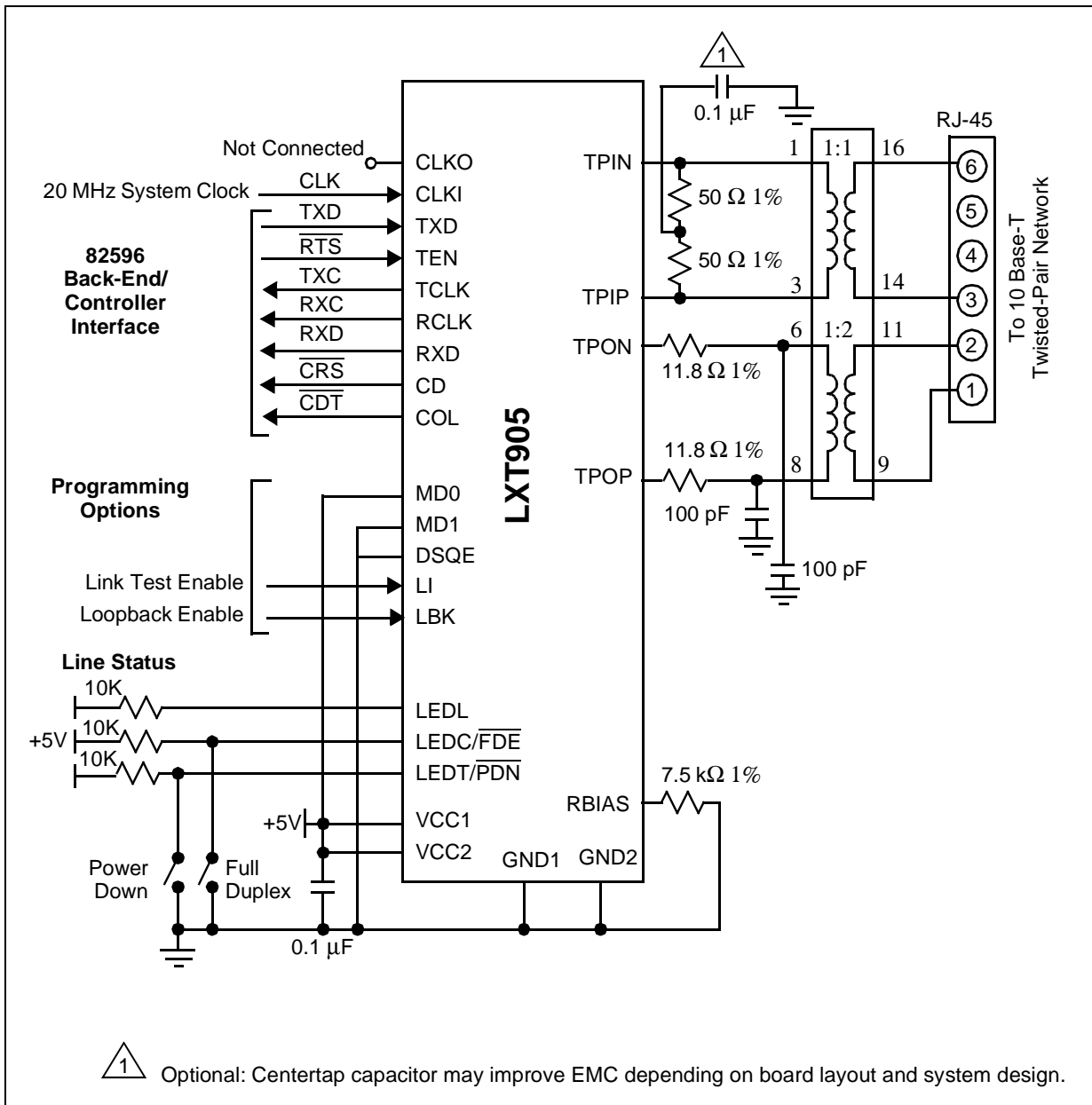

3.3 Dual Network Support - 10BASE-T and Token Ring

Figure 9 on page 20 shows the LXT905 with a Texas Instruments 380C26 CommProcessor. The 380C26 is compatible with Mode 4 (MD0 and MD1 both high). When used with the 380C26, both the LXT905 and a TMS38054 Token Ring transceiver can be tied to a single RJ-45 allowing dual network support from a single connector.

Figure 9. LXT905/380C26 Interface for Dual 10BASE-T and Token Ring Support (Mode 4)

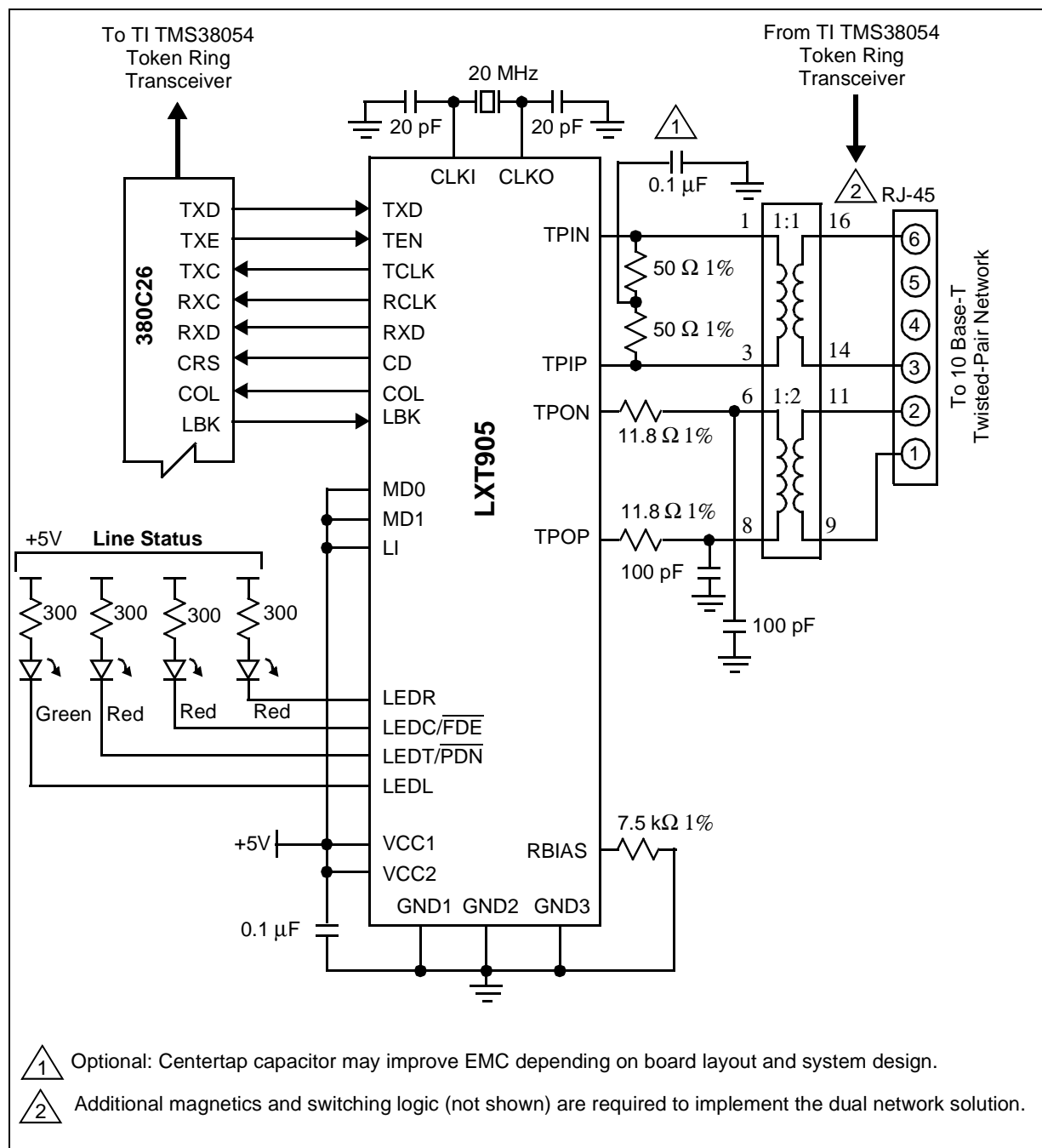

3.4 Simple 10BASE-T Connection

Figure 10 shows a simple 10BASE-T application using an LXT905 transceiver and a Motorola MC68EN360. The MC68EN360 is compatible with Mode 1 (MD0 and MD1 both Low).

Figure 10. LXT905/MC68EN360 Interface for Full-Duplex 10BASE-T (Mode 1)

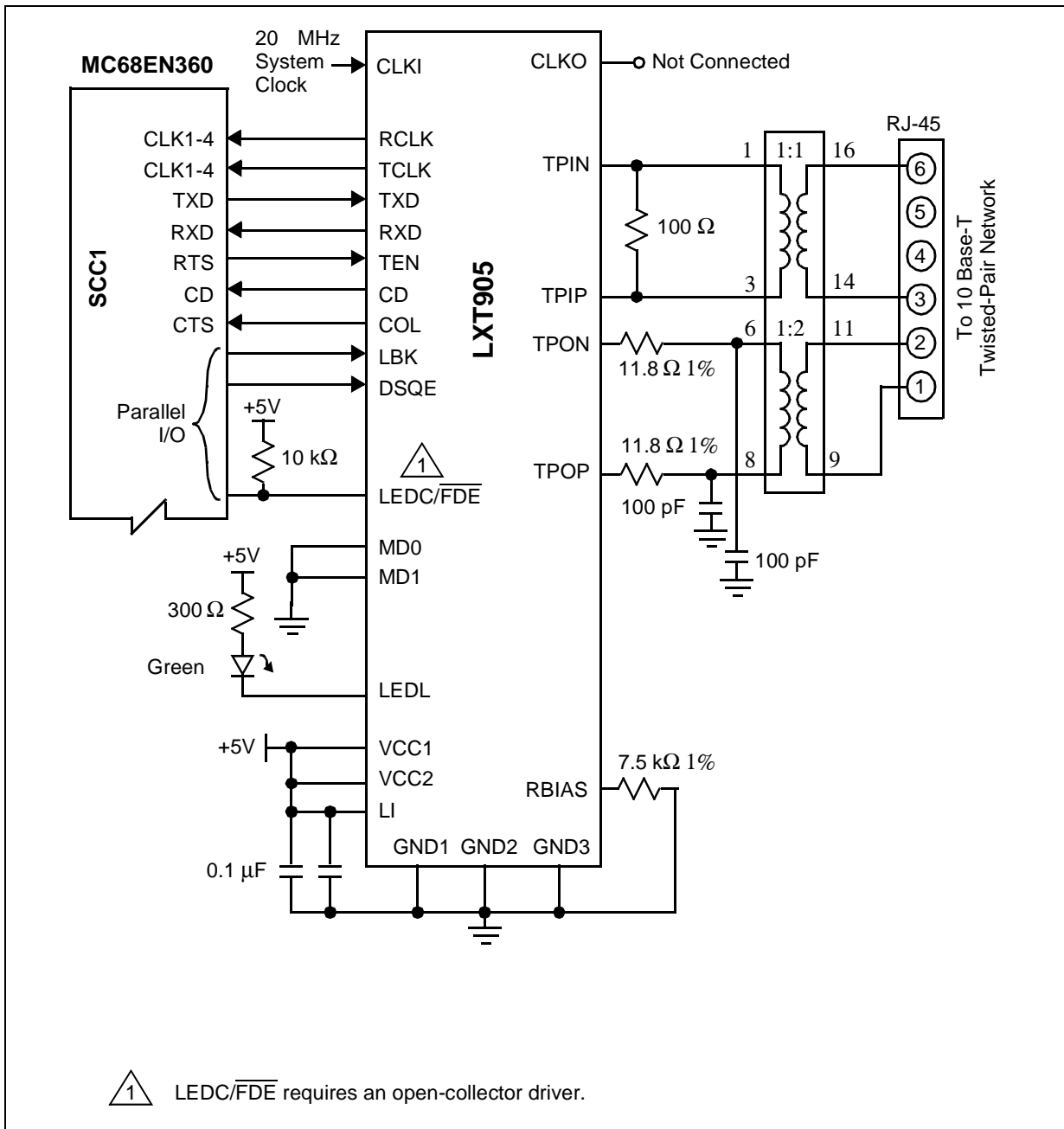

4.0 Test Specifications

Note: The minimum and maximum values in Table 5 through Table 13 on page 25 and Figure 11 on page 26 through Figure 26 on page 33 represent the performance specifications of the LXT905 and are guaranteed by test, except where noted by design. Minimum and maximum values in Table 7 through Table 13 on page 25 apply over the recommended operating conditions specified in Table 6.

For all Quality and Reliability issues (for example, parts packaging and thermal specifications), please send your questions to Intel at the following e-mail address: qr.requests@intel.com.

Table 5. Absolute Maximum Values

Parameter	Symbol	Min	Max	Units
Supply voltage	V _{CC}	-0.3	+6	V
Storage temperature	T _{ST}	-65	+150	°C
Caution: Exceeding these values may cause permanent damage. Functional operation under these conditions is not implied. Exposure to maximum rating conditions for extended periods may affect device reliability.				

Table 6. Recommended Operating Conditions

Parameter	Symbol	Min	Typ	Max	Units
Recommended supply voltage ¹	V _{CC}	3.135	5.0	5.25	V
Recommended operating temperature (Commercial)	T _{OP}	0	–	+70	°C
Recommended operating temperature (Extended)	T _{OP}	-40	–	+85	°C
1. Voltage is with respect to ground unless specified otherwise.					

Table 7. I/O Electrical Characteristics

Parameter	Sym	Min	Typ ¹	Max	Units	Test Conditions
Input low voltage ²	V _{IL}	–	–	0.8	V	
Input high voltage ²	V _{IH}	2.0	–	–	V	
Output low voltage	V _{OL}	–	–	0.4	V	I _{OL} = 1.6 mA
	V _{OL}	–	–	10	%V _{CC}	I _{OL} < 10 μA
Output low voltage (Open drain LED driver)	V _{OLL}	–	–	0.7	%V _{CC}	I _{OLL} = 10 mA
Output high voltage	V _{OH}	2.4	–	–	V	I _{OH} = 40 μA
	V _{OH}	90	–	–	%V _{CC}	I _{OH} < 10 μA
Output rise time TCLK & RCLK	CMOS	–	–	3	ns	C _{LOAD} = 20 pF
	TTL	–	–	2	ns	
1. Typical values are at 25 °C and are for design aid only, are not guaranteed, and are not subject to production testing. 2. Limited functional tests are performed at these input levels. The majority of functional tests are performed at levels of 0V and 3V. This applies to all inputs except TPIP and TPIN.						

Table 7. I/O Electrical Characteristics (Continued)

Parameter		Sym	Min	Typ ¹	Max	Units	Test Conditions
Output fall time TCLK & RCLK	CMOS	–	–	3	15	ns	C _{LOAD} = 20 pF
	TTL	–	–	2	15	ns	
CLKI rise time (externally driven)		–	–	–	10	ns	
CLKI duty cycle (externally driven)		–	–	50/50	40/60	%	
Supply current	Normal Mode	I _{CC}	–	40	80	mA	Idle Mode
		I _{CC}	–	70	100	mA	Transmitting on TP
	Power Down Mode	I _{CC}	–	0.01	1	µA	

1. Typical values are at 25 °C and are for design aid only, are not guaranteed, and are not subject to production testing.
2. Limited functional tests are performed at these input levels. The majority of functional tests are performed at levels of 0V and 3V. This applies to all inputs except TPIP and TPIN.

Table 8. TP Electrical Characteristics

Parameter	Symbol	Min	Typ ¹	Max	Units	Test Conditions
Transmit output impedance	Z _{OUT}	–	5	–	Ω	–
Transmit timing jitter addition ²	–	–	±6.4	±10	ns	0 line length for internal MAU
Transmit timing jitter added by the MAU and PLS sections ^{2,3}	–	–	±3.5	±5.5	ns	After line model specified by IEEE 802.3 for 10BASE-T internal MAU
Receive input impedance	Z _{IN}	–	24	–	kΩ	Between TPIP/TPIN
Differential squelch threshold	V _{DS}	300	420	585	mV	5 MHz square wave input

1. Typical values are at 25 °C and are for design aid only, are not guaranteed, and are not subject to production testing.
2. Parameter is guaranteed by design; not subject to production testing.
3. IEEE 802.3 specifies maximum jitter additions at 0.5 ns from the encoder, and 3.5 ns from the MAU.

Table 9. Switching Characteristics

Parameter		Symbol	Minimum	Typical ¹	Maximum	Units
Jabber Timing	Maximum transmit time	–	20	–	150	ms
	Unjab time	–	250	–	750	ms
Link Integrity Timing	Time link loss receive	–	50	–	150	ms
	Link min receive	–	2	–	7	ms
	Link max receive	–	50	–	150	ms
	Link transmit period	–	8	10	24	ms

1. Typical values are at 25 °C and are for design aid only, are not guaranteed, and are not subject to production testing.

Table 10. RCLK/Start-of-Frame Timing

Parameter	Symbol	Min	Typ ¹	Max	Units	
Decoder acquisition time	tDATA	–	1300	1500	ns	
CD turn-on delay	tCD	–	400	550	ns	
Receive data setup from RCLK	Mode 1	tRDS	60	70	–	ns
	Modes 2, 3, and 4	tRDS	30	45	–	ns
Receive data hold from RCLK	Mode 1	tRDH	10	20	–	ns
	Modes 2, 3, and 4	tRDH	30	45	–	ns
RCLK shut off delay from CD assert (Mode 3)	tsws	–	±100	–	ns	
1. Typical values are at 25 °C and are for design aid only, are not guaranteed, and are not subject to production testing.						

Table 11. RCLK/End-of-Frame Timing

Parameter	Type	Sym	Mode 1	Mode 2	Mode 3	Mode 4	Units
RCLK after CD off	Min	tRC	5	1	–	5	BT
Rcv data through-put delay	Max	tRD	400	375	375	375	ns
CD turn-off delay ²	Max	tCDOFF	500	475	475	475	ns
Receive block out after TEN off ³	Typical ¹	tIFG	5	50	–	–	BT
RCLK switching delay after CD off	Typical ¹	tswe	–	–	120 (±80)	–	ns
1. Typical figures are at 25 °C and are for design aid only; not guaranteed and not subject to production testing. 2. CD Turnoff delay measured from middle of last bit: timing specification is unaffected by the value of the last bit. 3. Blocking of Carrier Detect is disabled during full-duplex operation.							

Table 12. Transmit Timing

Parameter	Symbol	Minimum	Typical ¹	Maximum	Units
TEN setup from TCLK	tEHCH	22	–	–	ns
TXD setup from TCLK	tDSCH	22	–	–	ns
TEN hold after TCLK	tCHEL	5	–	–	ns
TXD hold after TCLK	tCHDU	5	–	–	ns
Transmit start-up delay	tSTUD	–	350	450	ns
Transmit through-put delay	tTPD	–	338	350	ns
1. Typical values are at 25 °C and are for design aid only, are not guaranteed, and are not subject to production testing.					

Table 13. Miscellaneous Timing

Parameter	Symbol	Minimum	Typical ¹	Maximum	Units
COL (SQE) Delay after TEN off ²	tSQED	0.65	–	1.6	μs
COL (SQE) Pulse Duration ²	tSQEP	500	–	1500	ns
Power Down recovery time	tPDR	–	25	–	ms
1. Typical values are at 25 °C and are for design aid only, are not guaranteed, and are not subject to production testing. 2. When SQE is enabled (DSQE is Low).					

4.1 Timing Diagrams for Mode 1 (MD1 = Low, MD0 = Low) Figures 11 - 14

Figure 11. Mode 1 RCLK/Start-of-Frame Timing

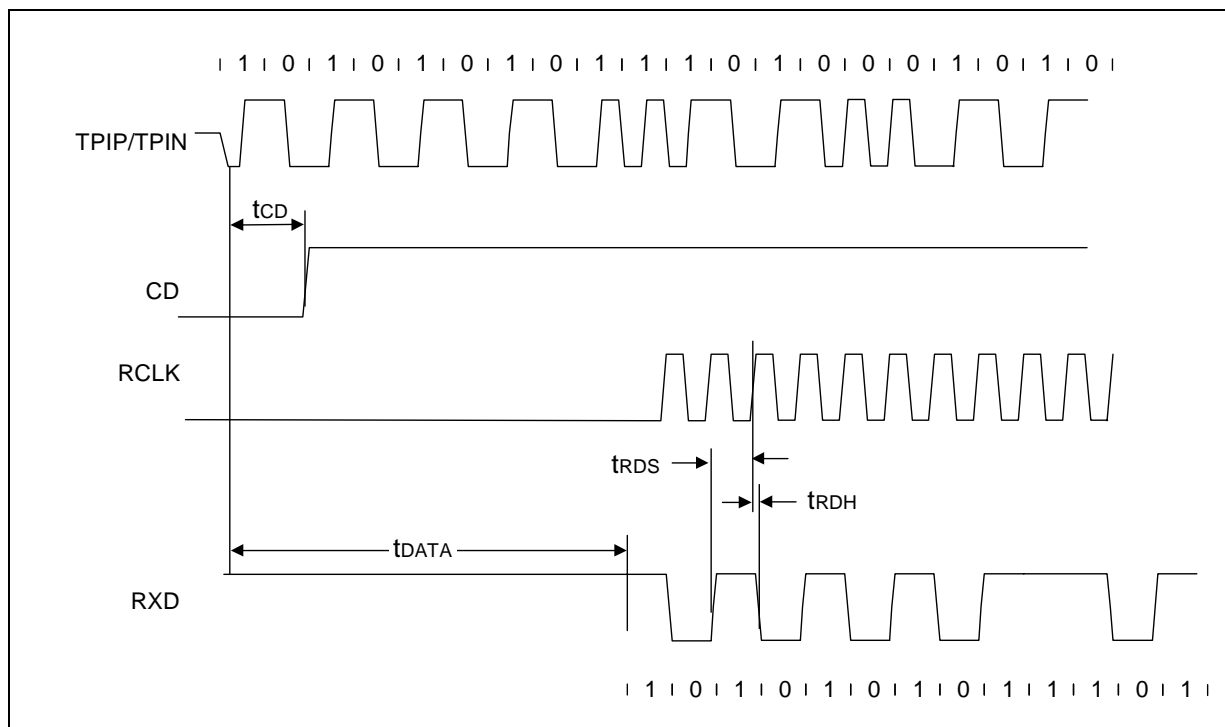

Figure 12. Mode 1 RCLK/End-of-Frame Timing

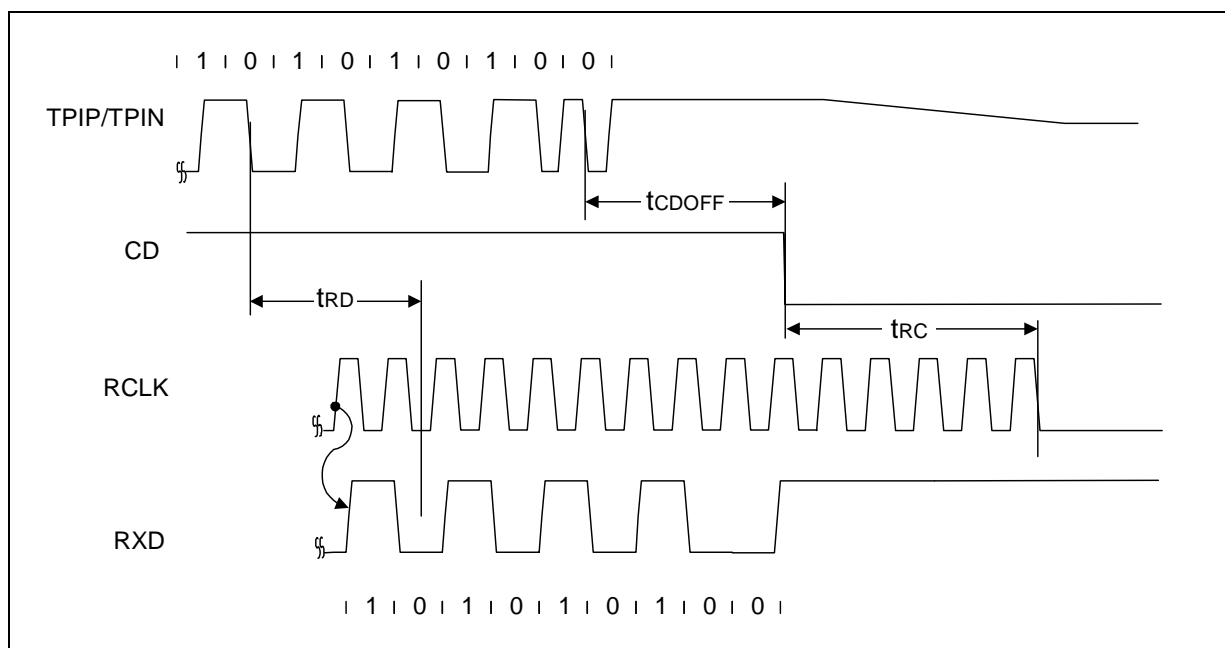

Figure 13. Mode 1 Transmit Timing

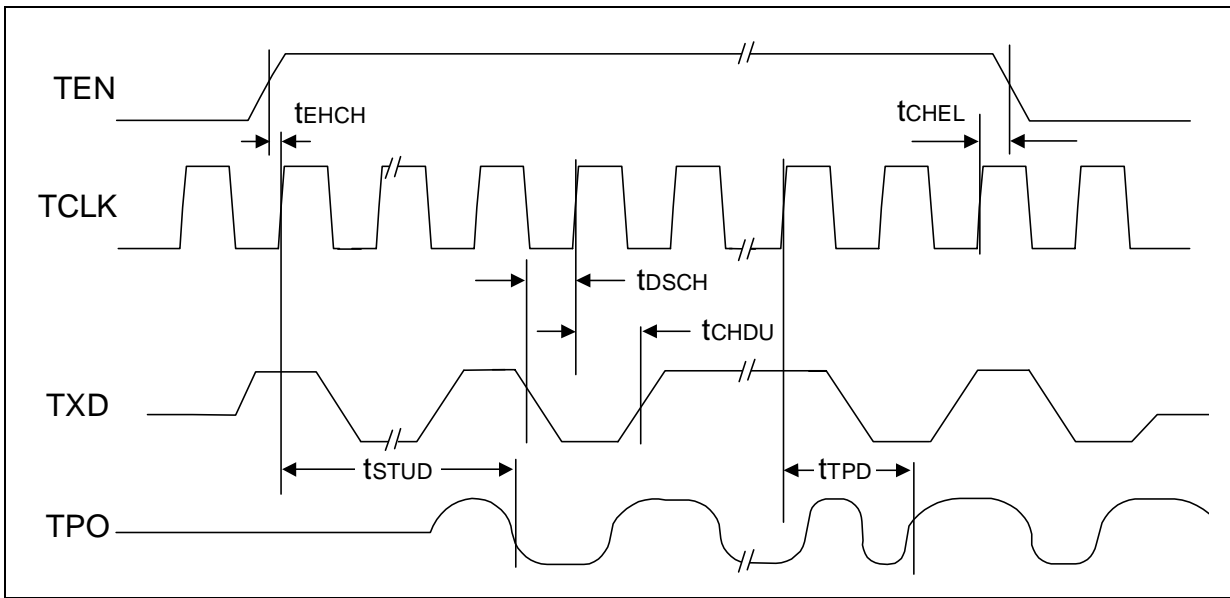
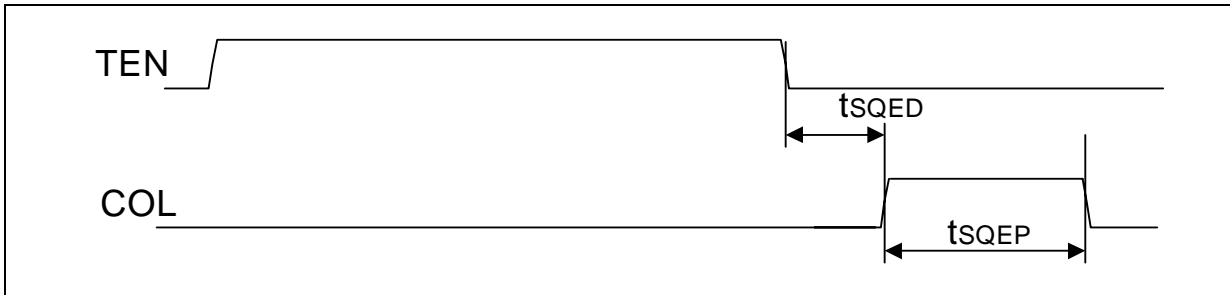

Figure 14. Mode 1 COL Output Timing



4.2 Timing Diagrams for Mode 2 (MD1 = Low, MD0 = High) Figures 15 - 18

Figure 15. Mode 2 RCLK/Start-of-Frame

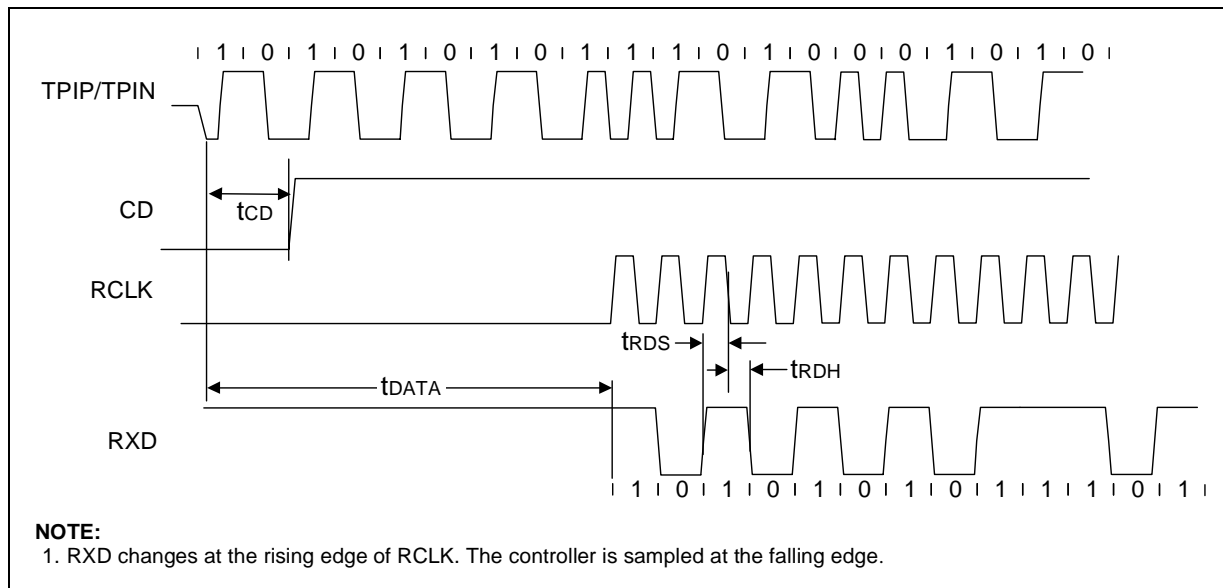

Figure 16. Mode 2 RCLK/End-of-Frame Timing

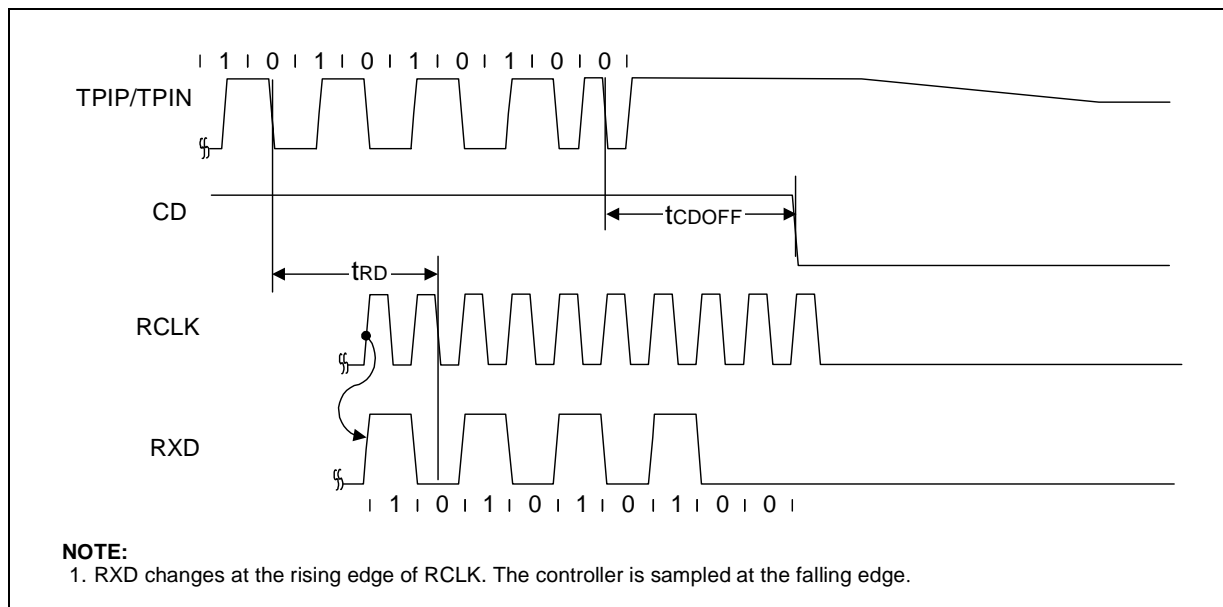

Figure 17. Mode 2 Transmit Timing

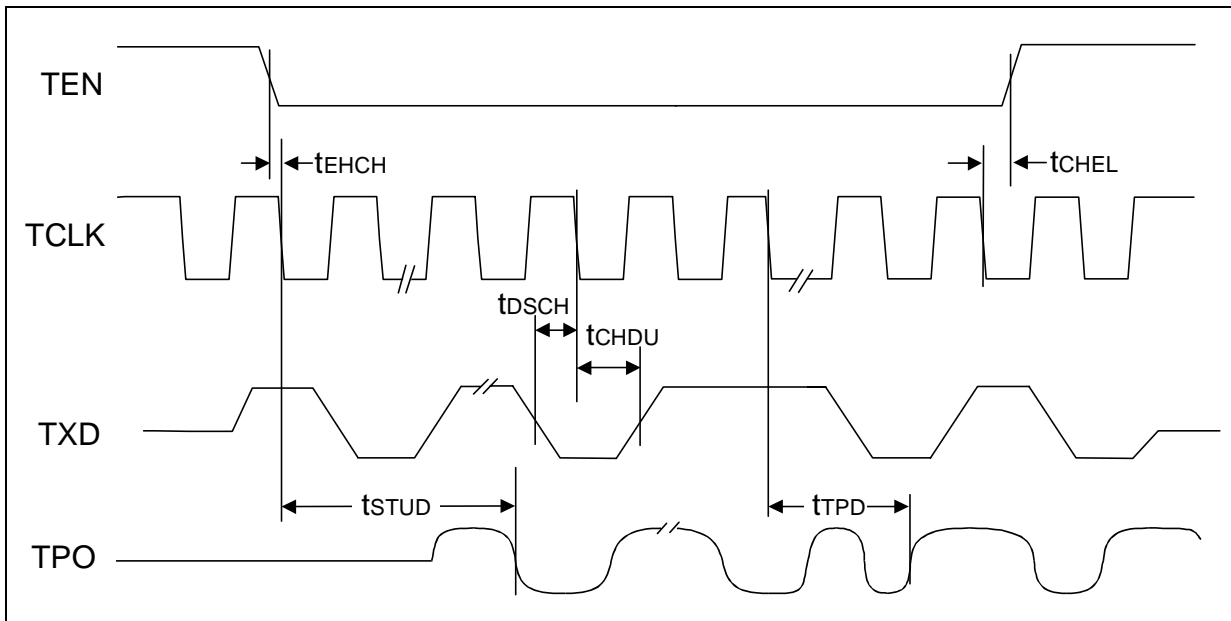
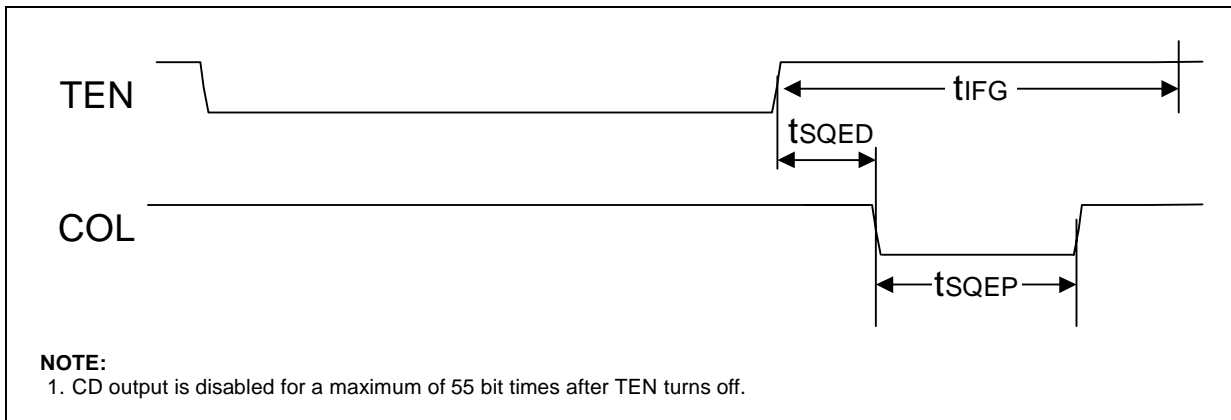

Figure 18. Mode 2 COL Output Timing



4.3 Timing Diagrams for Mode 3 (MD1 = High, MD0 = Low) Figures 19 - 22

Figure 19. Mode 3 RCLK/Start-of-Frame Timing

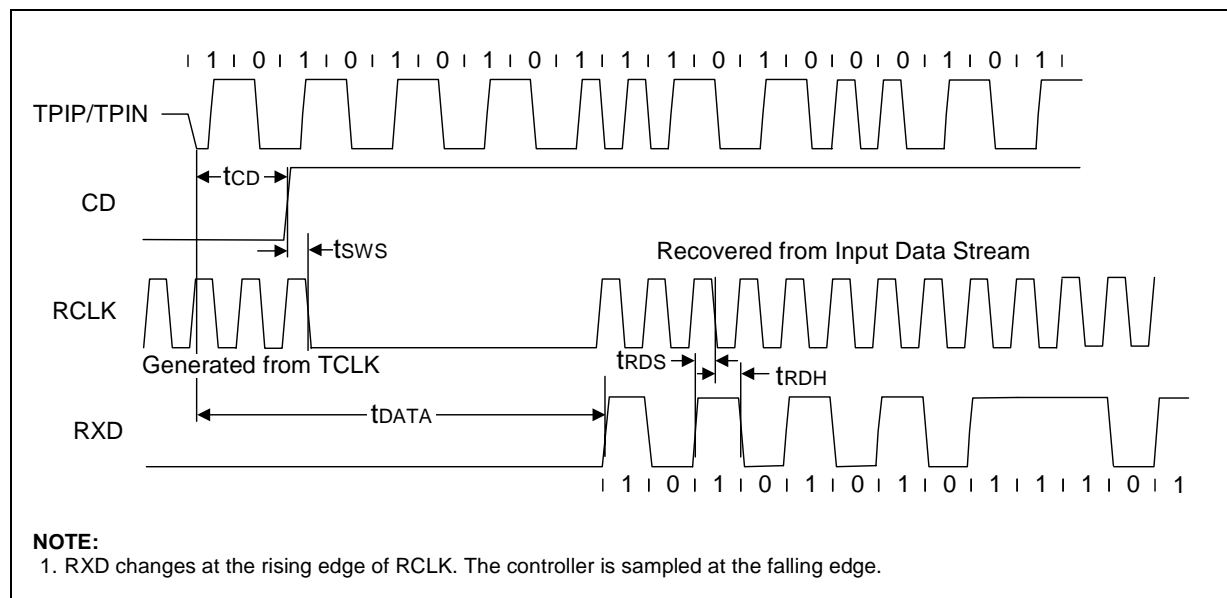

Figure 20. Mode 3 RCLK/End-of-Frame Timing

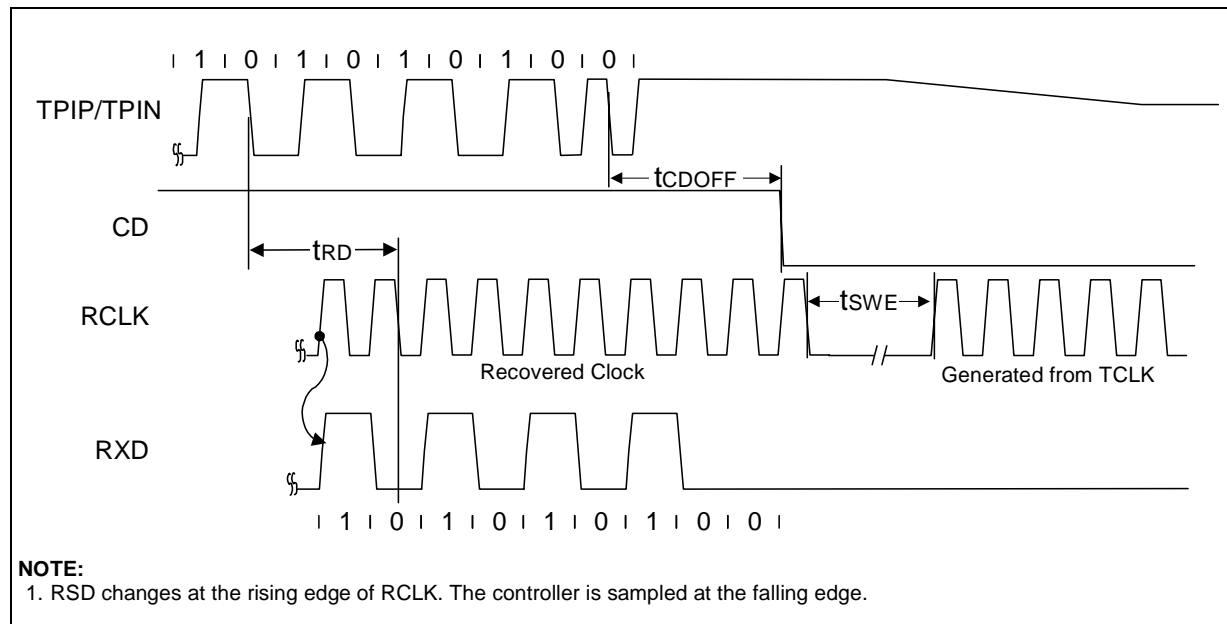

Figure 21. Mode 3 Transmit Timing

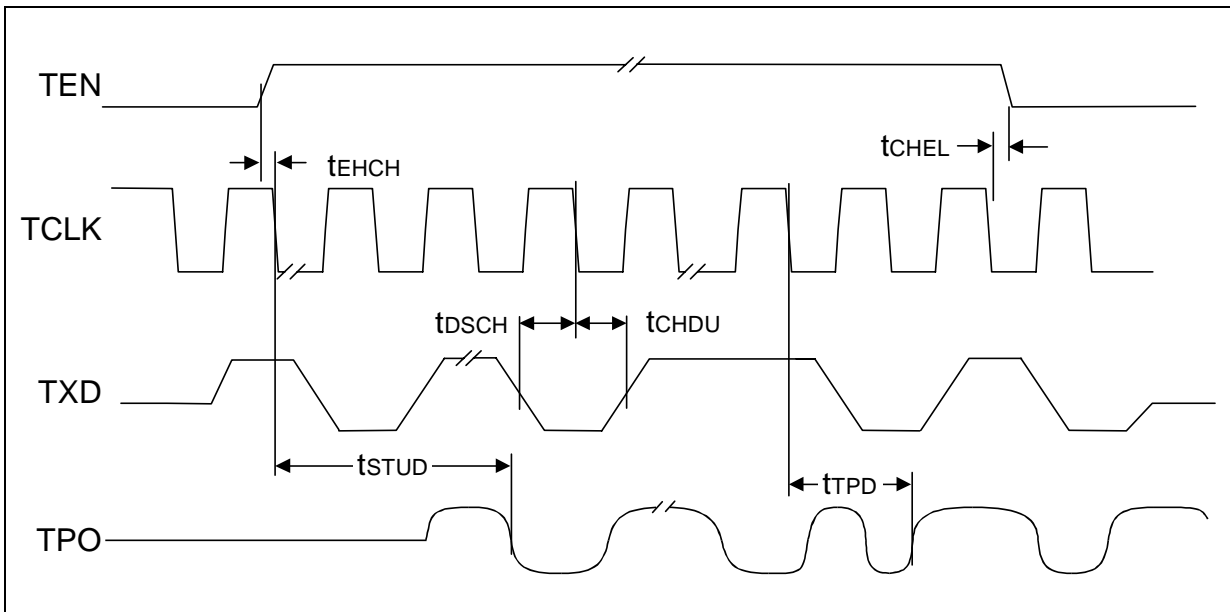
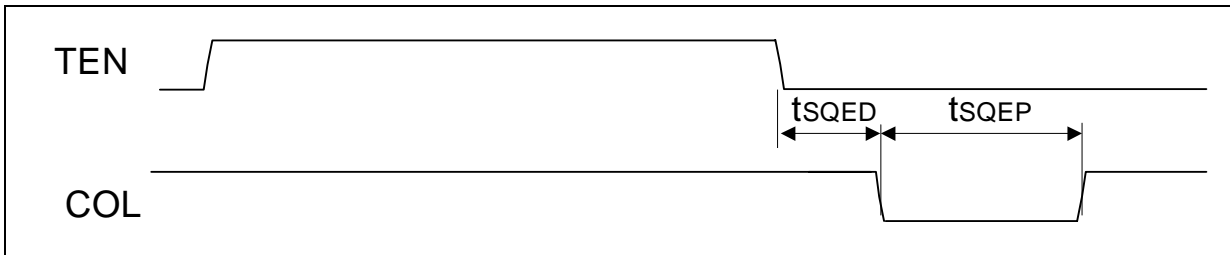

Figure 22. Mode 3 COL Output Timing



4.4 Timing Diagrams for Mode 4 (MD1 = High, MD0 = High) Figures 23 - 26

Figure 23. Mode 4 RCLK/Start-of-Frame Timing

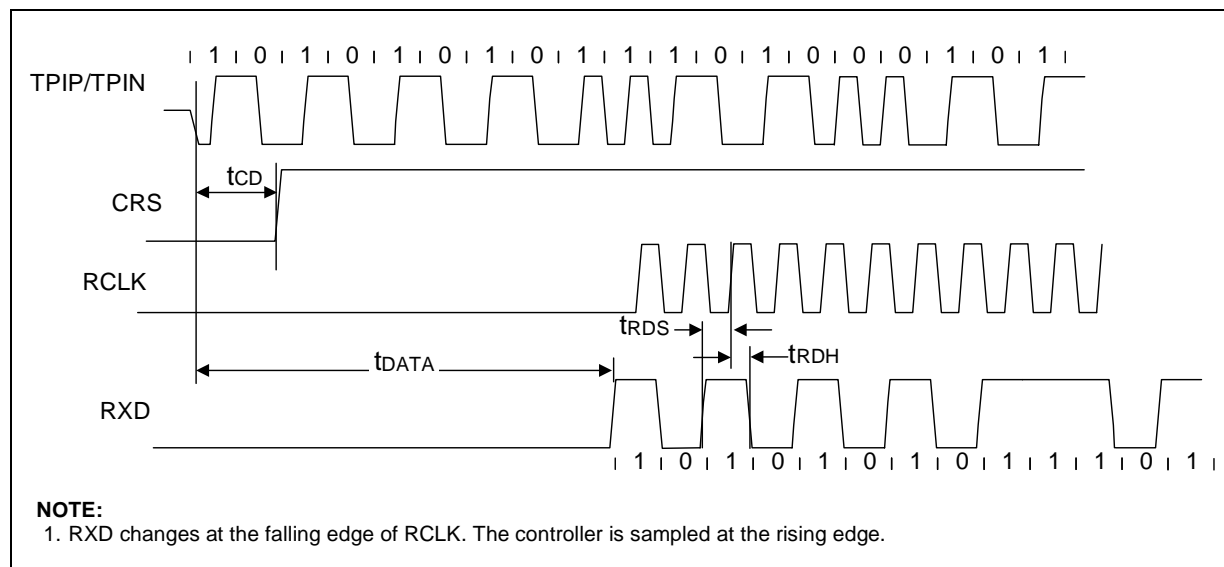

Figure 24. Mode 4 RCLK/End-of-Frame Timing

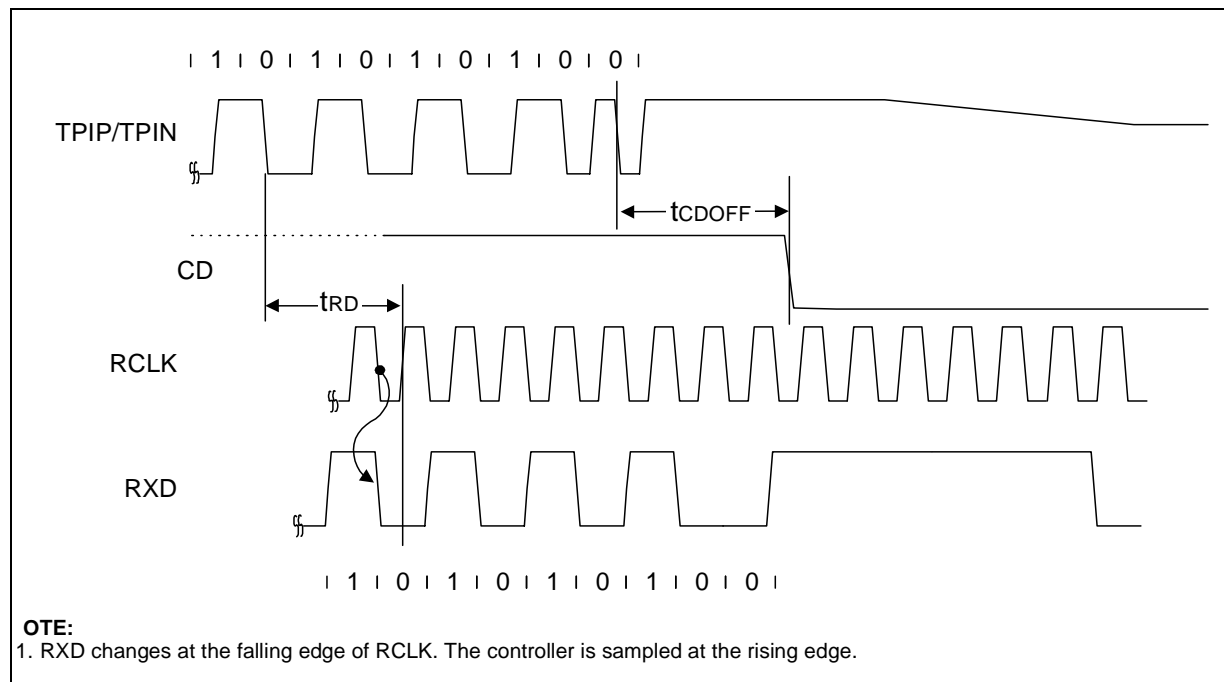

Figure 25. Mode 4 Transmit Timing

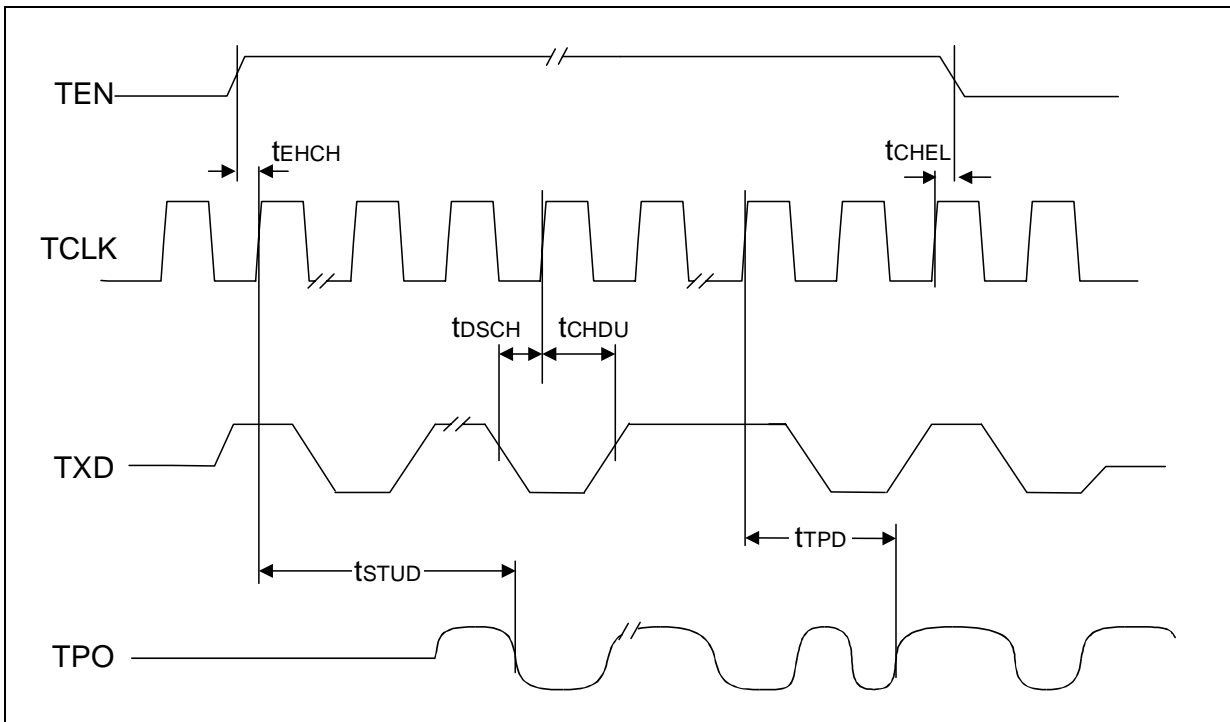
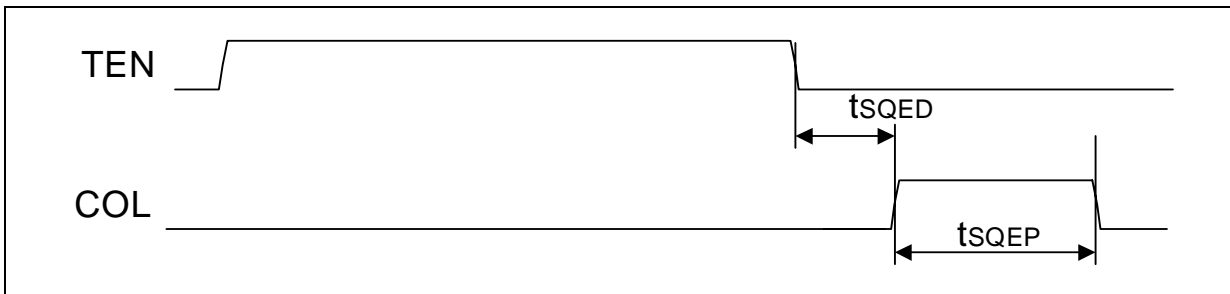

Figure 26. Mode 4 COL Output Timing



5.0 Mechanical Specifications

Figure 27. LXT905PC Package Specifications

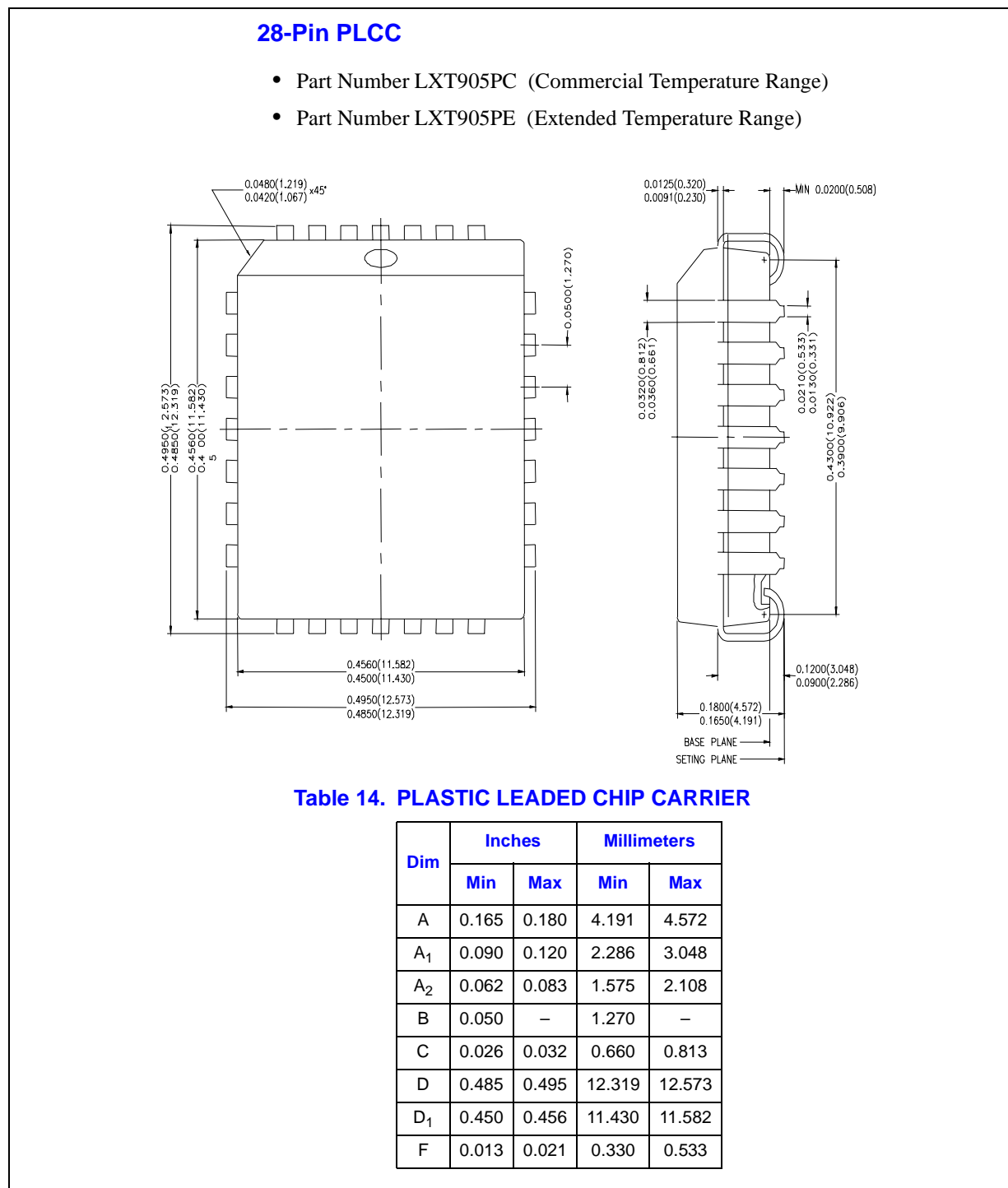

Figure 28. LXT905LC Package Specifications

32-Pin LQFP

- Part Number LXT905LC (Commercial Temperature Range)
- Part Number LXT905LE (Extended Temperature Range)

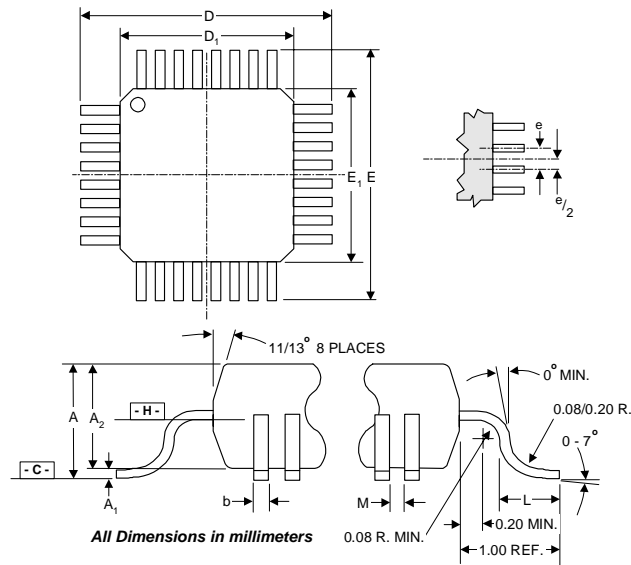

Table 15. QUAD FLAT PACKAGE

Dim.	All Dimensions in millimeters			Notes
	Min.	Typ.	Max.	
A	---	---	1.60	
A ₁	0.05	0.10	0.15	
A ₂	1.35	1.40	1.4	
D	9.00 BSC.			5
D ₁	7.00 BSC.			6, 7, 8
E	9.00 BSC			5
E ₁	7.00 BSC			6, 7, 8
L	0.45	0.60	0.75	
M	0.15	---	---	
b	0.30	0.37	0.45	9
e	0.80 BSC.			

NOTES:

1. All dimensions are in millimeters.
2. This package conforms to JEDEC publication 95 registration MO-136, variation BC.
3. Datum plane -H- located at mold parting line and is coincident with leads where leads exit plastic body at bottom of parting line.
4. Measured at seating plane -C-.
5. Measured at datum plane -H-.
6. Dimensions D₁ and E₁ do not include mold protrusion. Allowable mold protrusion is 0.254 mm.
7. Package top dimensions are smaller than bottom dimensions. Top of package will not overhang bottom of package.
8. Dimension b does not include dambar protrusion. Allowable dambar protrusion is no more than 0.08 mm.

Appendix A Ordering Information

Table 16. Product Information

Number	Revision	Qualification	Tray MM	Tape & Reel MM
DJLXT905LC.C2	C2	S	831645	831804
NLXT905PC.C2	C2	S	831661	831817
DJLXT905LE.C2	C2	S	831646	831805
NLXT905PE.C2	C2	S	831662	831818

Figure 29. Ordering Information - Sample

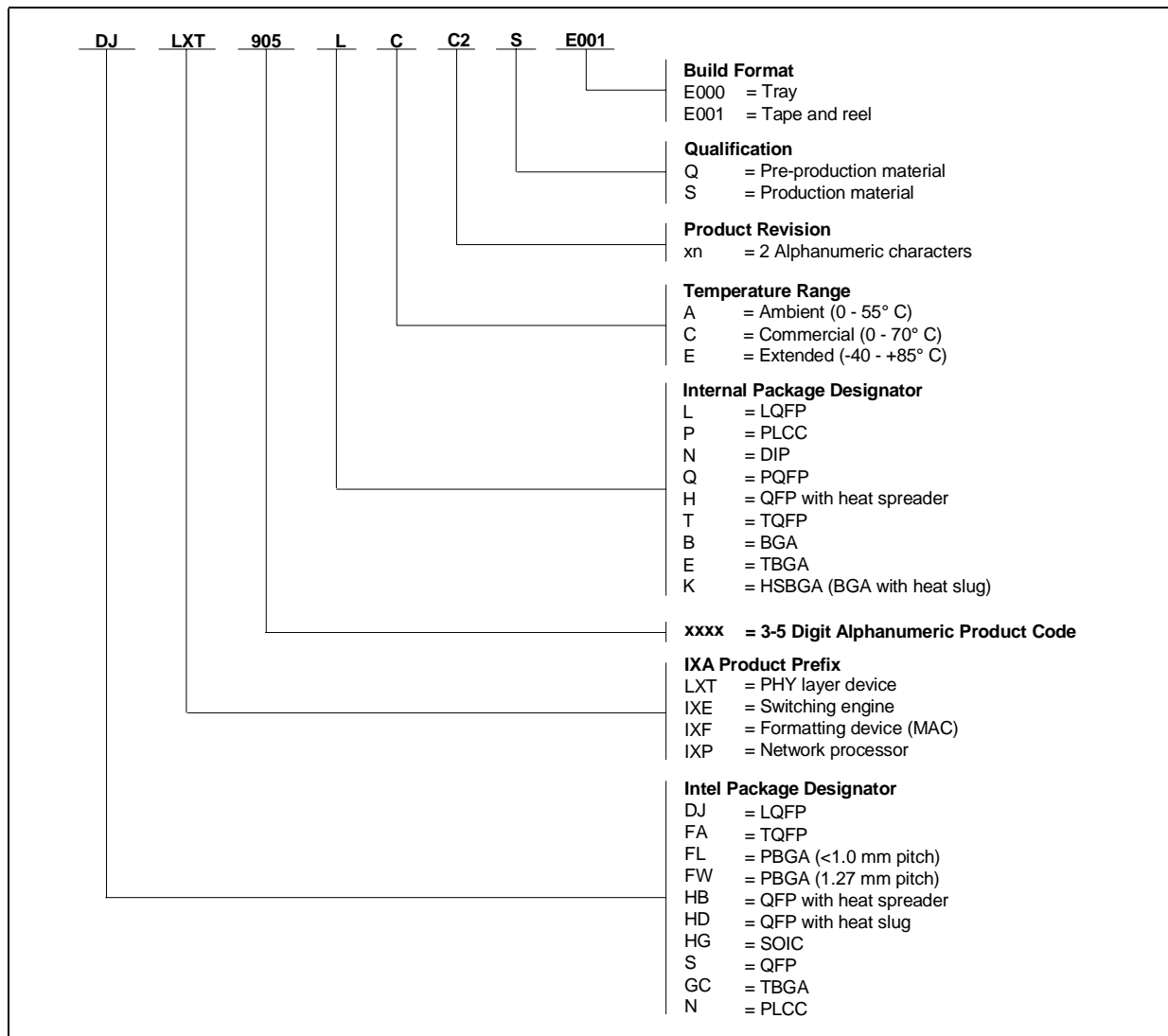

Looking for pricing, stock, or lifecycle information?

Click below to explore more details on WIN SOURCE:

- ⊖ [View EELXT905PC.C2 on WIN SOURCE](#)
- ⊖ [Copal Electronics Inc. Information](#)

Optimize Your Supply Chain with WIN SOURCE Solutions

- ✓ Global Sourcing Solution
- ✓ Obsolete Management
- ✓ Cost Control Management
- ✓ Shortage Management
- ✓ Alternative Solution
- ✓ Excess Inventory Management