

To: DIGI-KEY

Issue No. : E-L-R-D01-1
Date of Issue : March 14, 2006
Classification : New , Changed

PRODUCT SPECIFICATION FOR APPROVAL

Product Description : Specialty Polymer Aluminum Electrolytic Capacitor
Customer Part Number :
Product Part Number : EEFL****R
Country of Origin : Japan, Singapore
Printed on the packaging label
Applications : It has the intention of being used for a general electronic
Circuit given in a notice matter (limitation of a use).
On the occasion of application other than the above, even
person in charge of our company needs to inform in advance.

If you approve this specification, please fill in and sign the below and return 1copy to us.

Approval No	:	
Approval Date	:	
Executed by	:	_____
		(signature)
Title	:	
Dept.	:	

Capacitor Business Unit
Panasonic Electronic Devices Co., Ltd

25.Kohata-nishinaka.Uji City,
Kyoto, 611-8585, Japan
Phone (0774)32 - 1111
Phone : +81-774-31-7300(Direct)
Fax : +81-774-33-4251

Panasonic Electronic Devices Singapore
Pte. Ltd.

No.3 Bedok South Road, Singapore 469269,
THE REPUBLIC OF SINGAPORE

Prepared by : Engineering Group
Solid Engineering Team

Contact Person :
Signature
Name(Print) : H.Serikawa
Title : Engineer

Checked by :
Signature
Name(Print) : H.Yamamoto
Title : Manager

Authorized by :
Signature
Name(Print) : S.Iwamoto
Title : General Manager of Engineering

No. 3598458

Panasonic

Product Specification	E-L-R-D01-1
Specialty Polymer Aluminum Electrolytic Capacitors (L Series)	Page No. Contents

Contents

Notice matter	P.1
Scope	P.2
Parts Number	P.2
Parts Lists	P.3
Dimensions and Appearance	P.3
Marking	P.4
Specifications	P.4
Performance Characteristics	P.5 to P.7
Embossed tape dimension	P.8
Package Specifications	P.9 to P.10
Application Guidelines	P.11 to P.13
Maximum permissible reflow soldering temperature profile	P.14
Process Control flow Chart	P.15

Product Specification	E-L-R-D01-1
Specialty Polymer Aluminum Electrolytic Capacitors (L Series)	1

Notice matter

- ◆ Law and regulation which are applied
 - This product complies with the RoHS Directive (Restriction of the use of certain Hazardous Substances in electrical and electronic equipment DIRECTIVE 2002/95/EC).
 - No Ozone Depleting Chemicals(ODC's), controlled under the Montreal Protocol Agreement, are used in producing this product.
 - We do not PBBs or PBDEs as brominated flame retardants.
 - All the materials that are used for this product are registered as "Known Chemicals" in the Japanese act "Law Concerning the Examination and Regulation of Manufacture, etc. of Chemical Substances".
 - Export procedure which followed export related regulations, such as foreign exchange and a foreign trade method, on the occasion of export of this product Thank you for your consideration.

- ◆ Limitation of a use
 - This capacitor is designed to be used for electronics circuits such as audio/visual equipment, home appliances, computers and other office equipment, optical equipment, measuring equipment and industrial robots.
High reliability and safety are required [be / a possibility that incorrect operation of this product may do harm to a human life or property] more. When use is considered by the use, the delivery specifications which suited the use separately need to be exchanged.

- ◆ Country of origin : JAPAN,SINGAPORE

- ◆ Manufacturing factory : Capacitor Business Unit
 - Panasonic Electronic Devices Co., Ltd
 - 25, Kohata-nishinaka, Uji City, Kyoto 611-8585 Japan

 - Panasonic Electronic Devices Singapore Pte. Ltd.
 - No.3 Bedok South Road, Singapore 469269,
 - THE REPUBLIC OF SINGAPORE

Specialty Polymer Aluminum Electrolytic Capacitors (L Series)**1. Scope**

This specification applies to specialty polymer aluminum electrolytic capacitors type L series for use electronic equipment.

2. Explanation of Part Numbers

<u>E E F</u>	<u>OO</u>	<u>OO</u>	<u>OOO</u>	<u>OO</u>
2-1	2-2	2-3	2-4	2-5

2-1 Common code Specialty Polymer Aluminum Electrolytic Capacitor

2-2 Series code

2-3 Rated Voltage Code

R.V. code	0D	0E	0G	0J
R.V.(V.DC)	2	2.5	4	6.3

2-4 Capacitance Code : Indicating capacitance in μF by 3 letters.
 The first 2 figures are actual values and the third denotes the number of zeros.
 "R" denotes the decimal point and all figures are the actual number with "R".
 ex:4.7 μF ---- 4R7 10 μF ---- 100

2-5 Suffix Code

Suffix code	Packaging Style
R	Taping

Specialty Polymer Aluminum Electrolytic Capacitors (L Series)

3

Parts Lists

Part number	Rated Voltage (V.DC)	Cap. (μF)	tanδ max.	L.C. (μA) max.	ESR (mΩ) (100kHz,20°C) max.	Permissible Ripple Current A r.m.s.* 1
EEFLL0D181R	2	180	0.06	36.0	18	2.5
EEFLL0E151R	2.5	150	0.06	37.5	18	2.5
EEFLL0G101R	4	100	0.06	40.0	18	2.5
EEFLL0J470R	6.3	47	0.06	29.6	18	2.5

*1 100kHz/ 20°C to 105°C

V.DC \ μF	2 (0D)	2.5 (0E)	4 (0G)	6.3 (0J)
47 (470)				○
100 (101)			○	
150 (151)		○		
180 (181)	○			

(○) shows R.V and capacitance code.

3. Appearance, Dimensions

3.1 Appearance

By visual inspection, no deep cracks and blemishes.

3.2 Dimensions

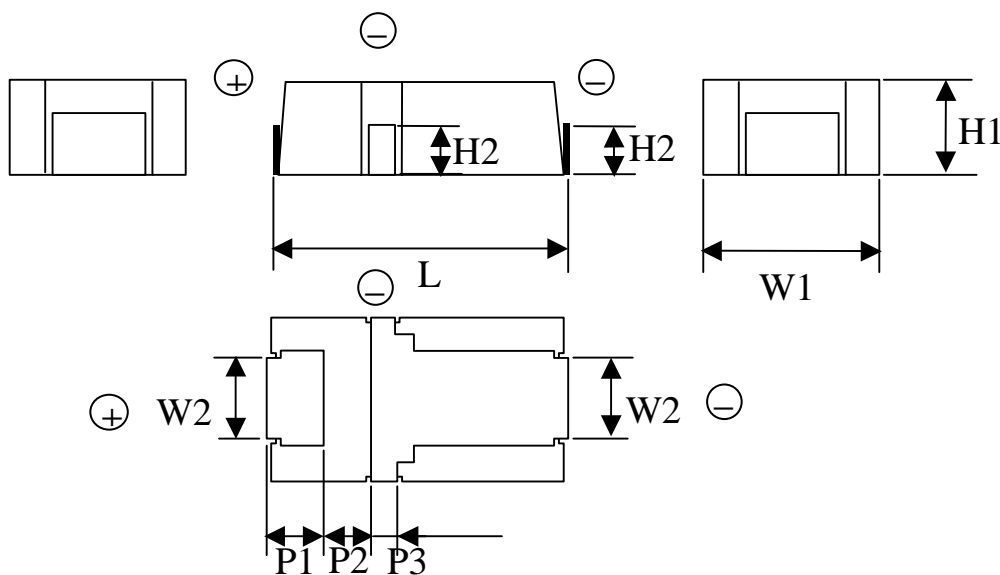

L ± 0.2	W1 ± 0.2	W2 ± 0.2	H1 ± 0.1	H2 ± 0.2	P1 ± 0.3	P2 ± 0.2	P3 ± 0.2
7.3	4.3	2.0	1.9	0.9	1.3	1.1	0.7

Specialty Polymer Aluminum Electrolytic Capacitors (L Series)

4

4. Marking

The following items on the capacitor' surface shall be legible during appearance inspection. These markings shall be shown by the method of indelible way.

- (1) Rated Voltage
- (2) Capacitance
- (3) Polarity
- (4) Lot No

(Notes) Body Color : Black
Marking : Laser

R.V.code

Marking code	d	e	g	j
R.V.(V.DC)	2	2.5	4	6.3

Code	Item
A	Polarity bar (Positive)
B	R.V. code
C*	Cap.
D	Lot No.

* "R" shows the decimal point.

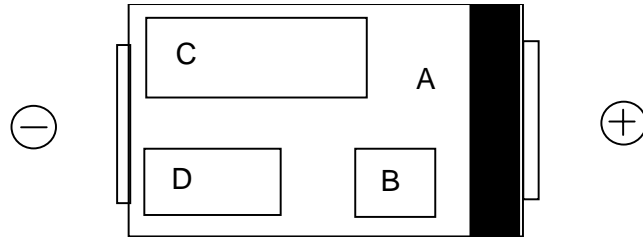

5. Specifications

	Item	Specifications					
1	Category temperature Range	-40°C to 105°C					
2	Rated voltage	2V to 6.3V					
3	Capacitance	47μF to 180μF(120Hz 20°C)					
4	Tolerance on capacitance	±20%(120Hz 20°C)					
5	Surge(V.DC)	V.DC	2	2.5	4	6.3	
		Surge	2.5	3.1	5	8	
6	Rated ripple current	P3 see attached individual specifications.					

Specialty Polymer Aluminum Electrolytic Capacitors (L Series)

5

6. Characteristics

No	Item	Characteristics		Outline of test method
1	Leakage current	$\leq 0.1CV$		Series resistor: 1000 Ω Applied voltage: Rated Voltage Measuring: 2min If you have doubts about the measured result, please re-check after the pre-conditioning explained below. Pre-conditioning Apply rated DC voltage for 1h at 105°C through 1000 Ω series resistor: Then discharge and keep in the room temperature for 24h to 48h
2	Capacitance tolerance	$\pm 20\%$		Measuring frequency: 120Hz $\pm 10\%$ Measuring circuit: Equivalent series circuit
3	$\tan\delta$	See attached individual specification(P.3)		Measuring voltage: +0V.DC $\leq 0.5V_{rms}$ Measuring temperature: 20°C
4	ESR	See attached individual specification (P.3)		Measuring frequency: 100kHz $\pm 10\%$ Measuring voltage: +0V.DC, $\leq 0.5V_{rms}$ Measuring temperature: 20°C
5	Solder-ability	More than 75% of the terminal face are covered by new solder.		Solder type: H60A or H63A Flax: About 25% rosin density melted ethanol Solder temperature: 230 ± 5 °C Immersing time: 2 ± 0.5 s
6	Solubility resistance to marking	Appearance: No remarkable abnormal change shall be occurred.		Class of reagent: Extra grade 2-propanol (JIS K8839) or superior. Test temperature: 20°C to 25°C Immersing time: 30 ± 5 s
7	Solder heat resistance	Leakage Current	\leq The value of item 1.	The capacitor is held on heating for reflow soldering. Reflow soldering profile: Please refer to Chapter 10 (Page 14)
		Capacitance Change	$\pm 10\%$ of initial measured value.	
		$\tan\delta$	\leq The value of item 3.	
		Appearance	No remarkable abnormal change shall be occurred.	
8	Adhesion	Appearance: Without mechanical damage such as breaks after test.		Push direction: Side Force: 5.0N Holding time: 10 ± 0.5 s
9	Damp heat, Steady state	Leakage Current	\leq The value of item 1.	Test temperature: 60 ± 2 °C Relative humidity: 90% Test time: 500 ⁺²⁴ ₀ h
		Capacitance Change	+70%,-20% (2V,2.5V) +60%,-20% (4V) +50%,-20% (6.3V) of initial measured value.	
		$\tan\delta$	$\leq 200\%$ of initial specified value.	
		Appearance	No remarkable abnormal change shall be occurred.	

Product Specification	E-L-R-D01-1
Specialty Polymer Aluminum Electrolytic Capacitors (L Series)	6

No	Item	Characteristics		Outline of test method													
10	Damp heat, Steady state (Applied voltage)	Leakage Current	≤The value of item 1.	Test temperature: 60±2°C Relative humidity: 90% Applied voltage: Rated voltage Test time: 500 ⁺²⁴ ₀ h													
		Capacitance Change	+70%,-20% (2V,2.5V) +60%,-20% (4V) +50%,-20% (6.3V) of initial measured value.														
		tanδ	≤200% of initial specified value.														
		Appearance	No remarkable abnormal change shall be occurred.														
11	Endurance	Leakage Current	≤The value of item 1.	Test temperature: 105±2°C Applied voltage: Rated voltage Test time: 1000 ⁺⁴⁸ ₀ h													
		Capacitance Change	±10% of initial measured value.														
		tanδ	≤The value of item 3.														
		Appearance	No remarkable abnormal change shall be occurred.														
12	Shelf life	Leakage Current	≤The value of item 1.	Test temperature: 105±2°C Test time: 500 ⁺²⁴ ₀ h													
		Capacitance Change	±10% of initial measured value.														
		tanδ	≤The value of item 3.														
		Appearance	No remarkable abnormal change shall be occurred.														
13	Characteristics at high and low temperature	Step	Item	Electrical Characteristics	Exposure the capacitor at each temperature in following order and measure characteristics at step 2,4 and 5 as described on the left. <table border="1" style="margin-left: 20px;"> <thead> <tr> <th>Step</th> <th>Temperature</th> </tr> </thead> <tbody> <tr> <td>1</td> <td>20±2°C</td> </tr> <tr> <td>2</td> <td>-40±3°C</td> </tr> <tr> <td>3</td> <td>20±2°C</td> </tr> <tr> <td>4</td> <td>105±2°C</td> </tr> <tr> <td>5</td> <td>20±2°C</td> </tr> </tbody> </table> If you have doubts about the result of its measurement, please make a re-check right after the pre-conditioning explained below. Pre-conditioning Dry the products 24h at 125°C	Step	Temperature	1	20±2°C	2	-40±3°C	3	20±2°C	4	105±2°C	5	20±2°C
		Step	Temperature														
		1	20±2°C														
		2	-40±3°C														
		3	20±2°C														
		4	105±2°C														
		5	20±2°C														
2	Capacitance	±15% of the value in step 1.															
	ESR	≤115% times of the value of item 4.															
4	Capacitance	20% of the value in step 1.															
5	Leakage current	≤The value of item 1.															
	Capacitance	±5% of the value in step 1.															
	tanδ	≤The value of item 3.															

Product Specification	E-L-R-D01-1
Specialty Polymer Aluminum Electrolytic Capacitors (L Series)	7

No	Item	Characteristics		Outline of test method
14	Surge	Leakage current	≤The value of item 1.	Test temperature: 15°C to 35°C Series resistor: 1000Ω Test voltage: Surge Applied voltage: 1000 cycles of 30±5s "ON" and 5min 30s "OFF"
		Capacitance change	±10% of initial measured value.	
		tanδ	≤The value of item 3.	
		Appearance	No remarkable abnormal change shall be occurred.	
15	Vibration	Appearance: No remarkable abnormal change shall be occurred. Capacitance: During test, measured value to be stabilized. (When measured several times within 30min before completion of test.)		Frequency: 10Hz to 2000Hz to 10Hz (One cycle per 20min) Total amplitude: 1.5mm Direction and duration of vibration: 2h each for three right-angle direction, total 6h. Mounting method: The capacitor must be soldered in place.

8. Packaging details of carrier tape

8.1 Details of carrier tape

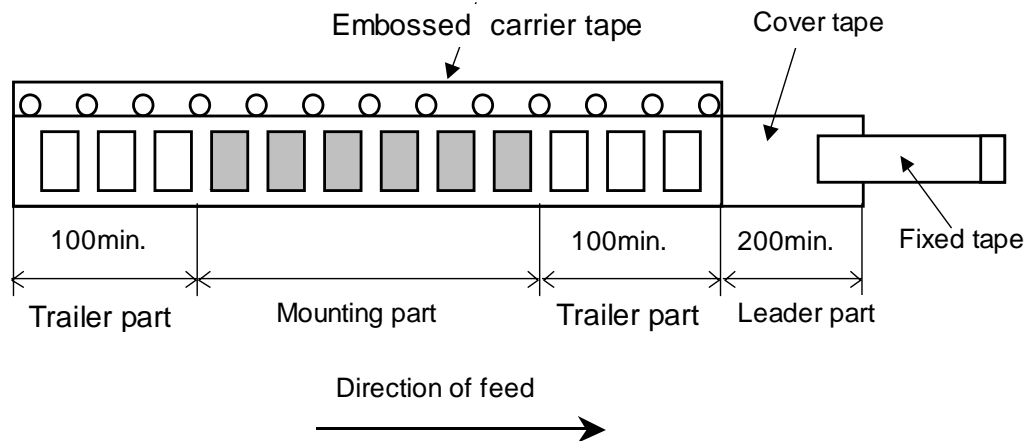

The cover tape shall not cover the sprocket holes

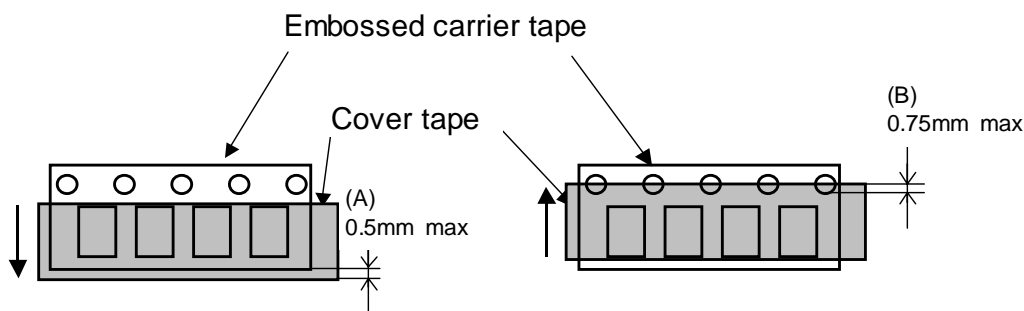

- a. Deviation between carrier tape and seal tape shall be less than 0.5mm
- b. Seal tape shall not be covered on the feeding holes more than 0.75mm

8.2 Adhesion test

Reasonable pulling strength: 0.1N to 0.7N

Pulling speed: 0.005m/s

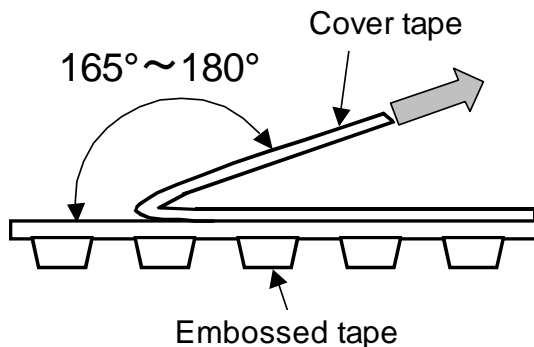

8.3 Packaging style

- 1) Carrier tape shall be reeling inside.(seal tape shall be outside.)
- 2) First of the carrier tape shall be inserted directly to the reel as shown in the below figure and leader part of seal tape shall not be attached.

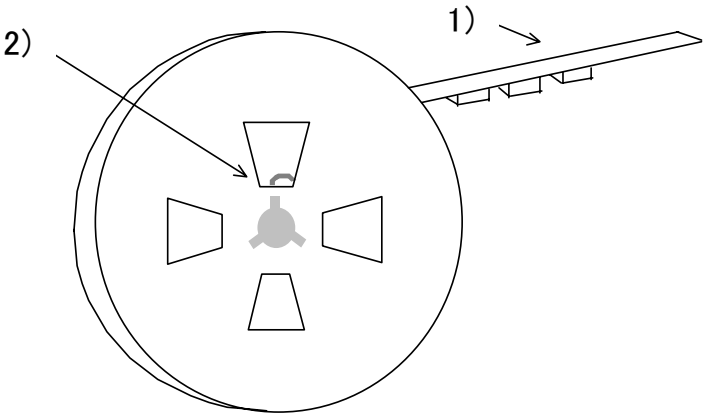

8.4 Dimensions of outer carton box

Dimensions of the carton box are subject to change without notice for adjustment to reel size.

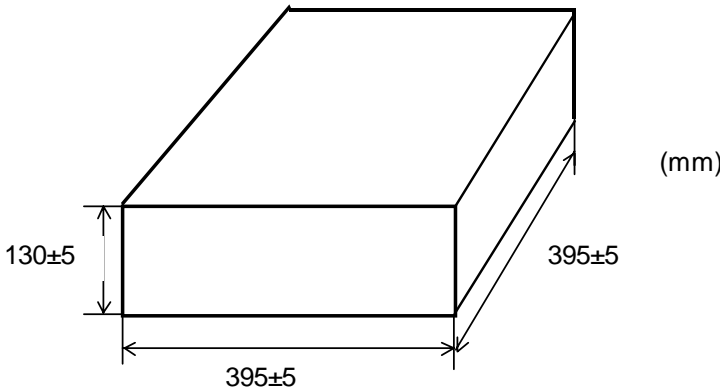

8.5 Packaging quantity

Quantity		
1 Reel(pcs)	1 Packaging box(reel)	Total Quantity(pcs)
3,500	5	17,500

Product Specification	E-L-R-D01-1
Specialty Polymer Aluminum Electrolytic Capacitors (L Series)	11

9.Application Guidelines

Specialty Polymer Aluminium Electrolytic Capacitor should be used in compliance with the following guidelines.

- (1) This specification guarantees the quality and performance of the product as individual components. Before use, check and evaluate their compatibility with installed in your products.
- (2) Do not use the products beyond the specifications described in this document.

9.1 Circuit Design

9.1.1 Prohibited Circuits for use

Do not use the capacitor with the following circuit.

- (1) Time-constant circuit
- (2) Coupling circuits
- (3) 2 or more capacitors connected serially
- (4) Circuit which are greatly affected by leakage current

9.1.2 Voltage

The application of over- voltage and reverse voltage described below can cause increases in leakage current and short circuits.

Applied voltage, refers to the voltage value including the peak value of the transitional Instantaneous voltage and the peak value of ripple voltage, not just steady line voltage.

Design your circuit so than the peak voltage does not exceed the stipulated voltage.

[Over-voltage]

Do not apply over-voltage in excess of the rated voltage.

Do not apply voltage, which exceeds the full rated voltage when the capacitors receive impulse voltage, instantaneous high voltage, high pulse voltage etc.

[Reverse-voltage]

Do not apply reverse-voltage

9.1.3 Ripple Current

Use the capacitors within the stipulated permitted ripple current.

When excessive ripple current is applied to the capacitor, it causes increases in leakage current and short circuits due to self-heating.

Even when using the capacitor under the permissible ripple current, reverse voltage may occur if the DC bias voltage is low.

9.1.4 Leakage Current

There is a risk of leakage current characteristics increasing even if the following use environments are within the stipulated range.

However, even if leakage current increases once, it has the characteristic that leakage current becomes small in most cases after voltage is applied due to its self-correction mechanism.

- (1) After re-flow
- (2) Shelf conditions such as (1) high temperature with no load, (2) high temperature high humidity with no load and (3) sudden temperature changes.

9.1.5 Failure Rate

The majority of failure modes are short circuits or increases in leakage current.

The main factors of failure are mechanical stress, heat stress and electric stress due to re-flow and heat from the use temperature environment.

Even within the stipulated limits, it is possible to lower the failure rate by reducing use conditions such as temperature and voltage. Please be sure to have ample margin in your design.

[Expected Failure Rate]

(1) Date based on our reliability tests: 46Fit or less (Based on applied rated voltage at 105°C)

(2) Market failure rate: 0.13Fit or less (Based on c=0, Reliability standard: 60%)

Product Specification	E-L-R-D01-1
Specialty Polymer Aluminum Electrolytic Capacitors (L Series)	12

Always consider safety when designing equipment and circuit. Plan for worst-case failure modes such as short circuits and open circuits which might occur during use.
 Install the following systems for a failsafe design to ensure safety if these products are to be used in equipment where a defect in these products may cause the loss of human life or other signification damage, such as damage to vehicles (automobile, train, vessel), traffic lights, medical equipment, aerospace equipment, electric heating appliances, combustion/gas equipment, rotating equipment, and disaster/crime prevention equipment.

- (1) The system is equipped with a protection circuit and protection device.
- (2) The system is equipped with a redundant circuit or other system to prevent an unsafe status in the event of a single fault.

9.2 Environments and Soldering for Using Capacitors

9.2.1 Storage

Products should be stored in a moisture proof environment. Storage conditions before and after opening the moisture proof packaging as follows.

(If these conditions are exceeded, the package may absorb moisture and there is a risk of damage to the exterior due to heat stress during mounting.)

[Environment of storage]

Temperature: 5°C to 30°C without direct sunlight

Humidity: Less than 70%

Maximum storage term before opening the package: JEDEC J-STD-020C MSL: Level 2

(2 years after manufactured)

Maximum storage condition after opening the package: JEDEC J-STD-020C MSL: Level 3

(7 days after opening)

Products should be all used within the storage term after opening the package.

After the storage limit, baking treatment is necessary to be able to use the products.

The storage conditions after baking are the same as those after opening the package.

[Baking conditions]

Temperature: 50±2°C

Time: 100h to 200h(Do not perform more than twice.)

9.2.2 Temperature

Use at or under the rated (guaranteed) temperature.

Operation at temperatures exceeding specifications causes large changes in the capacitors electrical properties, and deterioration than can potentially lead to failure.

When calculating the operating temperature of the capacitor, be sure to include not only the ambient temperature and internal temperature of the unit, but also radiation from heat generating elements inside the unit (power transistors, resistors, etc.), and self-heating due to ripple current.

9.2.3 Capacitor Mounting

(1) Land Size

Refer to the land size described next page for appropriate design dimensions. Circuit board design requires examination of the most suitable dimensions taking conditions such as circuit board, parts and re-flow into consideration.

These products are designed specifically for re-flow soldering. Consult with our factory before performing mounting processes other than re-flow soldering.

Typical land pattern (mm)

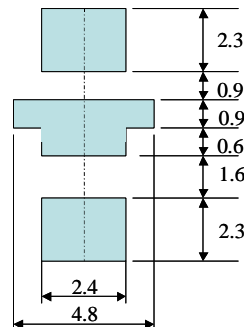

Product Specification	E-L-R-D01-1
Specialty Polymer Aluminum Electrolytic Capacitors (L Series)	13
<p>(2) Heat stress of re-flow, etc. Specified re-flow conditions must be strictly observed. Soldering under other conditions can cause short circuits and increases in ESR.</p> <p>(3) Repair and modification by soldering iron. When using a soldering iron, set the tip temperature to no more than 350°C, and work in as short a time as possible under 10s. While soldering, do not apply strong force to the capacitor.</p> <p>(4) Mechanical stress Do not apply excessive force to the capacitor, since this can damage the electrodes and badly affect the capacitor's mountability. It can also cause the increase of leakage current, separation of the lead wire and element, and damage to the capacitor body, all of which can badly affect the electrical performance of the capacitor.</p> <p>9.2.4 Transportation Take sufficient care during handling because excessive vibration, or shock can cause the reliability of the capacitor to decrease.</p> <p>9.2.5 Circuit Board Cleaning Products should be cleaned after soldering in accordance with the following conditions. Temperature: Less than 60°C Time: Within 5min(Ultrasound OK) Be sure to sufficiently wash and dry (20min at 100°C) the board afterward. [Recommended cleaning solvents] Pine Alpha ST-100S, Clean-thru 750H, Clean-thru 750L, Clean-thru710M, Aqua Cleaner 210SEP Sunelec B-12, DK beclear CW-5790, Techno Cleaner 219, Cold Cleaner P3-375, Telpen Cleaner EC-7R Techno Care FRW-17, Techno Care FRW-1, Techno care FRV-1, AXREL32 Note1: Consult our factory when performing processes with cleaning solvents other than those listed above. 2: The use of ozone depleting cleaning agents are not recommended in the interest of protecting the environment.</p> <p><u>9.3 Others</u></p> <p>9.3.1 Precautions for using capacitors Before using the products, carefully check the effects on their quality and performance, and determined whether or not they can be used. These products are designed and manufactured for general-purpose and standard use in general electronic equipment. These products are not intended for use in the following special conditions.</p> <ol style="list-style-type: none"> (1) In liquid, such as Water, Oil, Chemicals, or Organic solvent (2) In direct sunlight, outdoors, or in dust (3) In vapor, such as dew condensation water of resistive element, or water leakage, salty air, or air with a high concentration corrosive gas, such as Cl₂, H₂S, NH₃, SO₂, or NO₂ (4) In an environment where strong static electricity or electromagnetic waves exist (5) Mounting or placing heat-generating components or inflammables, such as vinyl-coated wires, near these products (6) Sealing or coating of these products or a printed circuit board on which these products are mounted, with resin and other material (7) Using solvent, water or water-soluble cleaner for flux cleaning agent after soldering. (In particular, when using water or a water-soluble cleaning agent, be careful not to leave water residues) (8) Acid or alkaline environments. (9) Environment subject to excessive vibration and shock. <p>9.3.2 Emergency Procedures If the capacitor is overheated, the resin case may emit smoke. If this occurs, immediately switch off the unit's main power supply to stop operation. Keep your face and hands away from the capacitor, since the temperature may be high enough to cause the capacitor to ignite and burn.</p> <p>9.3.3 Capacitor Disposal Since capacitors are composed of various metals and resins, treat them as industrial waste when arranging for their disposal.</p>	

10. Maximum permissible reflow soldering temperature profile

We recommend soldering shall be done according to following maximum permissible reflow soldering temperature profile.

Reflow soldering

Method: Hot air or infrared furnace.

Temperature measurement point: Top of capacitor.

Measuring method: Thermo-couple(K: $\phi 0.1\text{mm}$)

Reflow profile:

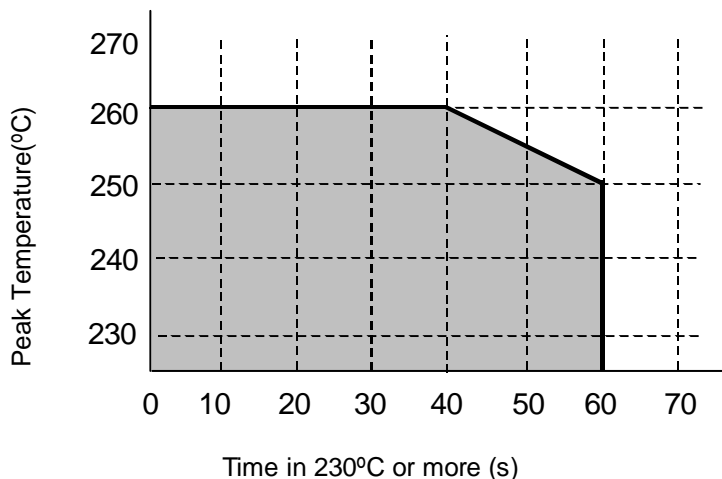
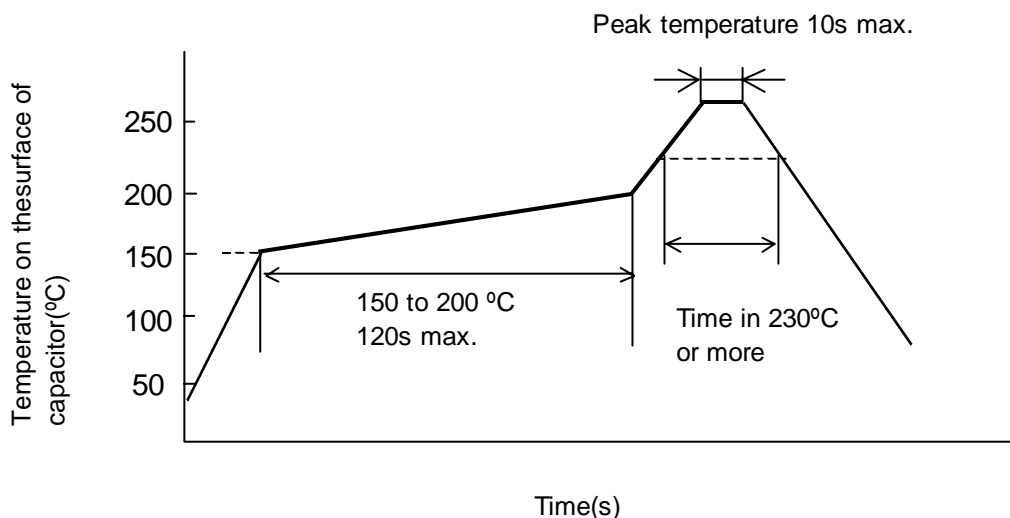

Ex.

Peak Temp.	Time in 230°C or more
260°C, 10s max.	40s max.
250°C, 10s max.	60s max.

Reflow times: 2max.

Note: Please refer to item 9.2.1 of the Application Guidelines for the proper storing conditions prior to the second reflow.

(The second reflow soldering should be performed in 5 days after the first one.)



11.Process Control flow Chart

Speciality Polymer Aluminium Electrolytic Capacitors Process Control Chart

Part names	Flow chart	Procss name	Control item	Part names	Flow chart	Procss name	Control item	
Aluminum foil		Acceptance inspection		Terminal		Acceptance inspection		
Chemicals		Etching	Etching conditions Multiplying factor Foil strength Chlorine compounds	Coating resin		Element mounting	Dimensions	
Chemicals		Acceptance inspection		Acceptance inspection		Shaping	Dimensions Appearance	
		Forming	Forming conditions			Marking (Laser marking)	Parts number Lot number	
		Slitting	Formed film Capacitance			aging	Temperature Voltage	
Tape materials		Acceptance inspection		Acceptance inspection		Final	Capacitance tanδ Leakage curent ESR	
		Sticking Punching	Tape position			Packaging materials	Packaging	Quantity
Chemicals		Acceptance inspection		Acceptance inspection		Control test	Endurance,terminal intensity etc	
		First forming	Forming			Outgoing inspection	Capacitance tanδ Leakage curent ESR	
Chemicals		Acceptance inspection		Acceptance inspection		Shipment	Appearance	
		Electrolytic polymerization	Polymerization conditions polymerization film					
Chemicals		Acceptance inspection		Acceptance inspection				
Cathode materials		Coating	Cure conditions					

Looking for pricing, stock, or lifecycle information?

Click below to explore more details on WIN SOURCE:

-  [View EEF-LL0J470R on WIN SOURCE](#)
-  [Panasonic Information](#)

Optimize Your Supply Chain with WIN SOURCE Solutions

-  Global Sourcing Solution
-  Obsolete Management
-  Cost Control Management
-  Shortage Management
-  Alternative Solution
-  Excess Inventory Management