

## Stacked Coin Type

Series : F



### Features

- Endurance : +85 °C 1000 h
- RoHS compliant

### Recommended Applications

- Backup of data/RTC of base station, electronic meter, and industrial equipment

### Specifications

Category temp. range	-25 °C to +85 °C	
Maximum operating voltage	5.5 V.DC	
Nominal cap.range	0.1 F to 1.0 F	
Characteristics at low temperature	Capacitance change	±30 % of initial measured value at +20 °C (at -25 °C)
	Internal resistance	≤ 5 times of initial measured value at +20 °C (at -25 °C)
Endurance	After 1000 hours application of 5.5 V.DC at +85 °C, the capacitor shall meet the following limits.	
	Capacitance change	±30 % of initial measured value
Shelf Life	After 1000 hours storage at +85 °C without load, the capacitor shall meet the specified limits for Endurance.	
	Internal resistance	≤ 4 times of initial specified value

### Dimensions in mm(not to scale)

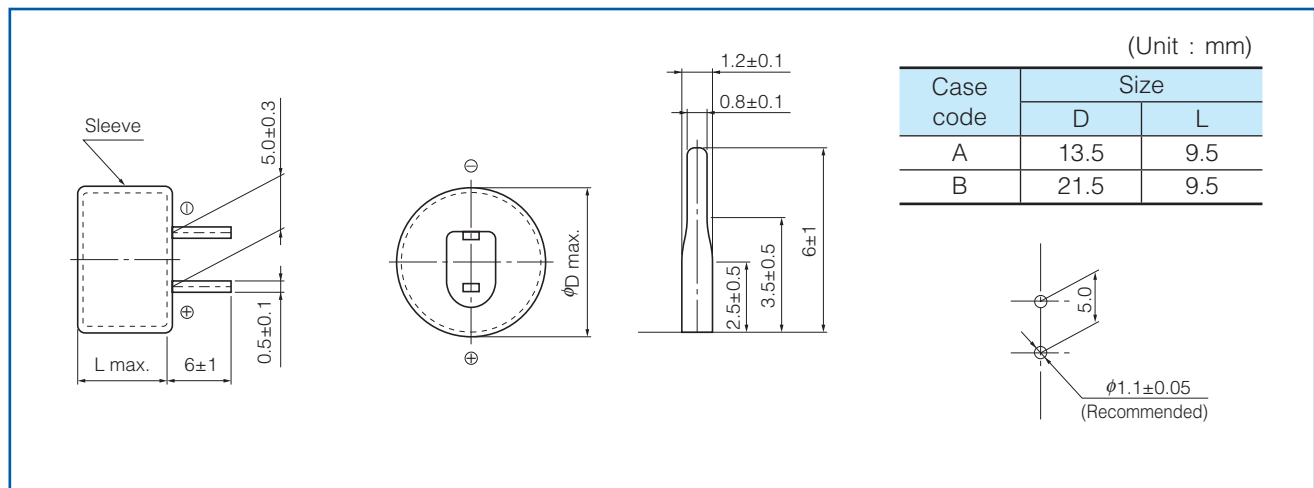

### Characteristics list

Maximum operating voltage (V.DC)	Capacitance (F)	Capacitance tolerance (F)	Internal resistance (Initial specified value) (Ω) at 1 kHz	Recommended discharge current	Parts number	Case code	Mass (Reference value) (g)	Min. packaging q'ty (pcs)
5.5	0.10	0.080 to 0.180	≤ 100	300 μA or less	EECF5R5H104	A	3.3	200
	0.47	0.376 to 0.846	≤ 75	1 mA or less	EECF5R5H474	B	10.0	100
	0.68	0.544 to 1.224	≤ 50	1 mA or less	EECF5R5H684	B	10.0	100
	1.00	0.80 to 1.80	≤ 50	1 mA or less	EECF5R5H105	B	10.0	100

Note : Do not use reflow soldering. (IR, Atmosphere heating methods, etc.)  
Please refer to the page of "Application guidelines".

## Guidelines and precautions regarding the technical information and use of our products described in this online catalog.

- If you want to use our products described in this online catalog for applications requiring special qualities or reliability, or for applications where the failure or malfunction of the products may directly jeopardize human life or potentially cause personal injury (e.g. aircraft and aerospace equipment, traffic and transportation equipment, combustion equipment, medical equipment, accident prevention, anti-crime equipment, and/or safety equipment), it is necessary to verify whether the specifications of our products fit to such applications. Please ensure that you will ask and check with our inquiry desk as to whether the specifications of our products fit to such applications use before you use our products.
- The quality and performance of our products as described in this online catalog only apply to our products when used in isolation. Therefore, please ensure you evaluate and verify our products under the specific circumstances in which our products are assembled in your own products and in which our products will actually be used.
- If you use our products in equipment that requires a high degree of reliability, regardless of the application, it is recommended that you set up protection circuits and redundancy circuits in order to ensure safety of your equipment.
- The products and product specifications described in this online catalog are subject to change for improvement without prior notice. Therefore, please be sure to request and confirm the latest product specifications which explain the specifications of our products in detail, before you finalize the design of your applications, purchase, or use our products.
- The technical information in this online catalog provides examples of our products' typical operations and application circuits. We do not guarantee the non-infringement of third party's intellectual property rights and we do not grant any license, right, or interest in our intellectual property.
- If any of our products, product specifications and/or technical information in this online catalog is to be exported or provided to non-residents, the laws and regulations of the exporting country, especially with regard to security and export control, shall be observed.

## <Regarding the Certificate of Compliance with the EU RoHS Directive/REACH Regulations>



- The switchover date for compliance with the RoHS Directive/REACH Regulations varies depending on the part number or series of our products.
- When you use the inventory of our products for which it is unclear whether those products are compliant with the RoHS Directive/REACH Regulation, please select "Sales Inquiry" in the website inquiry form and contact us.

**We do not take any responsibility for the use of our products outside the scope of the specifications, descriptions, guidelines and precautions described in this online catalog.**

---

## Looking for pricing, stock, or lifecycle information?

Click below to explore more details on WIN SOURCE:

-  [View EEC-F5R5H104](#) on WIN SOURCE
-  [Panasonic](#) Information

## Optimize Your Supply Chain with WIN SOURCE Solutions

-  Global Sourcing Solution
-  Obsolete Management
-  Cost Control Management
-  Shortage Management
-  Alternative Solution
-  Excess Inventory Management