



Technical Data Sheet **Preliminary**

**0603 Package Chip LED (0.6mm Height leadframe)**

**19-013/Y2SC-AQ2R2B/3T**

**Features**

- package:SMT package 0603
- wavelength: 587 nm (Brilliant Yellow)
- viewing angle: extremely wide (140°)
- grouping parameter: luminous intensity, wavelength
- assembly methods:suitable for all SMT assembly methods
- soldering methods:reflow soldering
- preconditioning: acc. to JEDEC Level 2
- taping: 8 mm tape with 3000/reel
- ESD-withstand voltage:up to 2 kV acc. to JESD22-A114-B

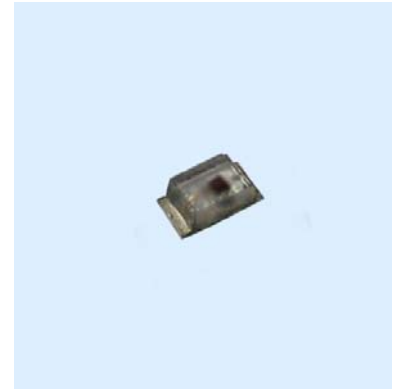

**Descriptions**

- The 19-013 SMD LED is much smaller than through hole type components, thus enable smaller board size, higher packing density, reduced storage space and finally smaller equipment to be obtained.
- Besides, lightweight makes them ideal for miniature applications. etc.

**Applications**

- outdoor displays
- flat backlighting(LCD,cellular phones,switches,displays)
- signal and symbol luminary
- marker light (e.g.steps,exit ways,etc.)

**Device Selection Guide**

Part No.	Chip		Resin Color
	Material	Emitted Color	
19-013/Y2SC-AQ2R2B/3T	AlGaInP	Brilliant Yellow	Water Clear

**Package Outline Dimensions**

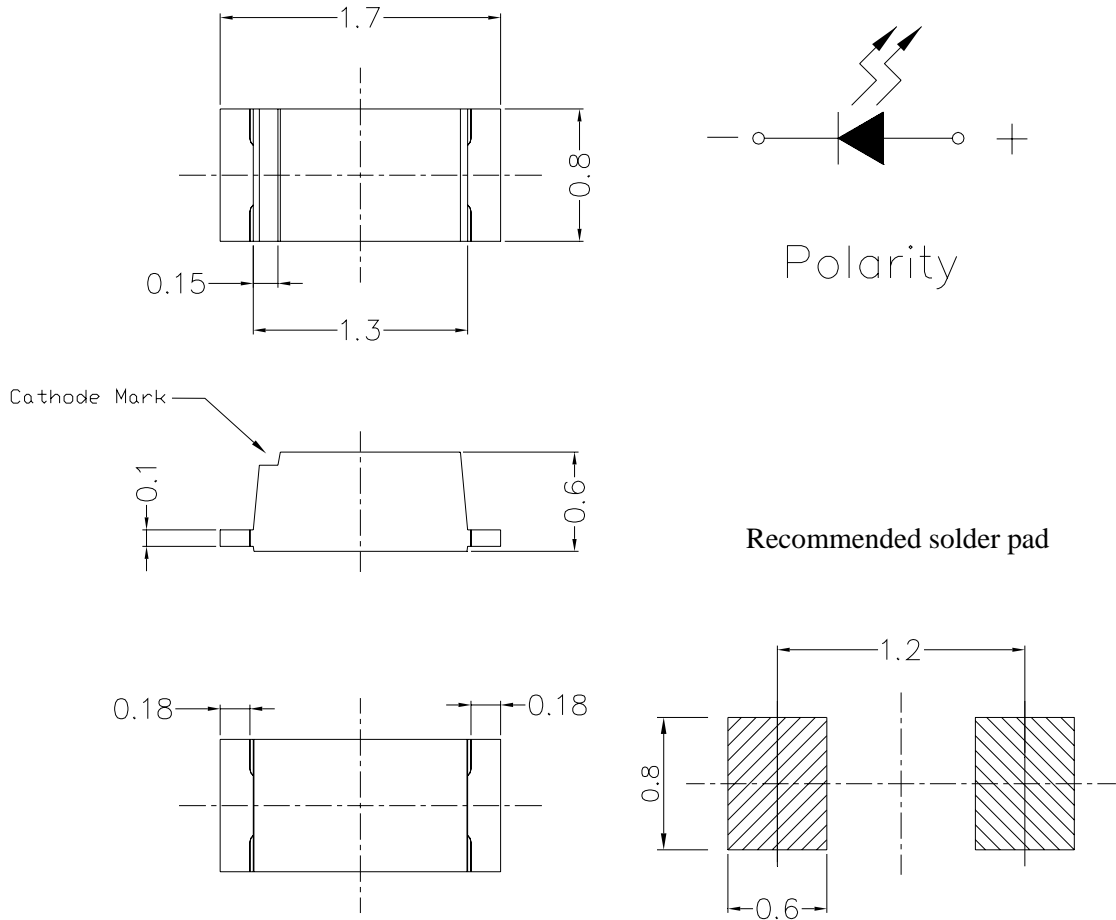

**Note:** The tolerances unless mentioned is  $\pm 0.1\text{mm}$ , Unit = mm

**Absolute Maximum Ratings (Ta=25°C)**

Parameter	Symbol	Rating	Unit
Reverse Voltage	V <sub>R</sub>	12	V
Forward Current	I <sub>F</sub>	30	mA
Peak Forward Current (Duty 1/10 @1KHz)	I <sub>FP</sub>	100	mA
Power Dissipation	P <sub>d</sub>	80	mW
Electrostatic Discharge(HBM)	ESD	2000	V
Operating Temperature	T <sub>opr</sub>	-40 ~ +100	°C
Storage Temperature	T <sub>stg</sub>	-40 ~ +100	°C
Soldering Temperature	T <sub>sol</sub>	Reflow Soldering : 260 °C for 10 sec. Hand Soldering : 350 °C for 3 sec.	

**Electro-Optical Characteristics (Ta=25°C)**

Parameter	Symbol	Min.	Typ.	Max.	Unit	Condition
Luminous Intensity	I <sub>v</sub>	90.0	-----	180	mcd	I <sub>F</sub> =20mA
Viewing Angle	2θ 1/2	-----	140	-----	deg	
Peak Wavelength	λ <sub>p</sub>	-----	591	-----	nm	
Dominant Wavelength	λ <sub>d</sub>	585.5	-----	594.5	nm	
Spectrum Radiation Bandwidth	△λ	-----	20	-----	nm	
Forward Voltage	V <sub>F</sub>	1.75	-----	2.35	V	
Reverse Current	I <sub>R</sub>	-----	-----	10	μA	V <sub>R</sub> =12V

**Notes:**

- 1.Tolerance of Luminous Intensity ±11%**
- 2.Tolerance of Dominant Wavelength ±1nm**
- 3.Tolerance of Forward Voltage ±0.1V**

**Bin Range Of Luminous Intensity**

Bin	Min	Max	Unit	Condition
Q2	90.0	112	mcd	IF=20mA
R1	112	140		
R2	140	180		

**Bin Range Of Dom. Wavelength**

Group	Bin	Min	Max	Unit	Condition
A	D3	585.5	588.5	nm	IF=20mA
	D4	588.5	591.5		
	D5	591.5	594.5		

**Bin Range Of Forward Voltage**

Group	Bin	Min	Max	Unit	Condition
B	0	1.75	1.95	V	IF=20mA
	1	1.95	2.15		
	2	2.15	2.35		

**Notes:**

- 1.Tolerance of Luminous Intensity  $\pm 11\%$
- 2.Tolerance of Dominant Wavelength  $\pm 1\text{nm}$
- 3.Tolerance of Forward Voltage  $\pm 0.1\text{V}$

**Typical Electro-Optical Characteristics Curves**

**Typical curve of spectral distribution:**

$V(\lambda)$ =Standard eye response curve

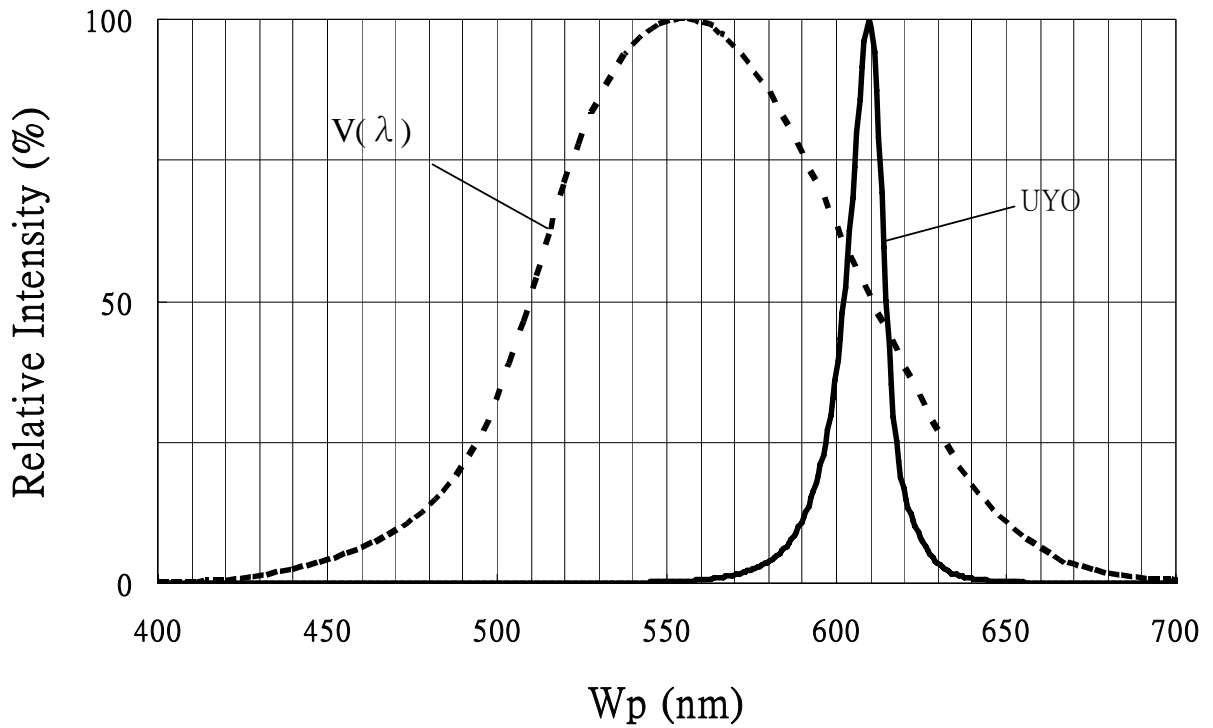

**Diagram characteristics of radiation:**

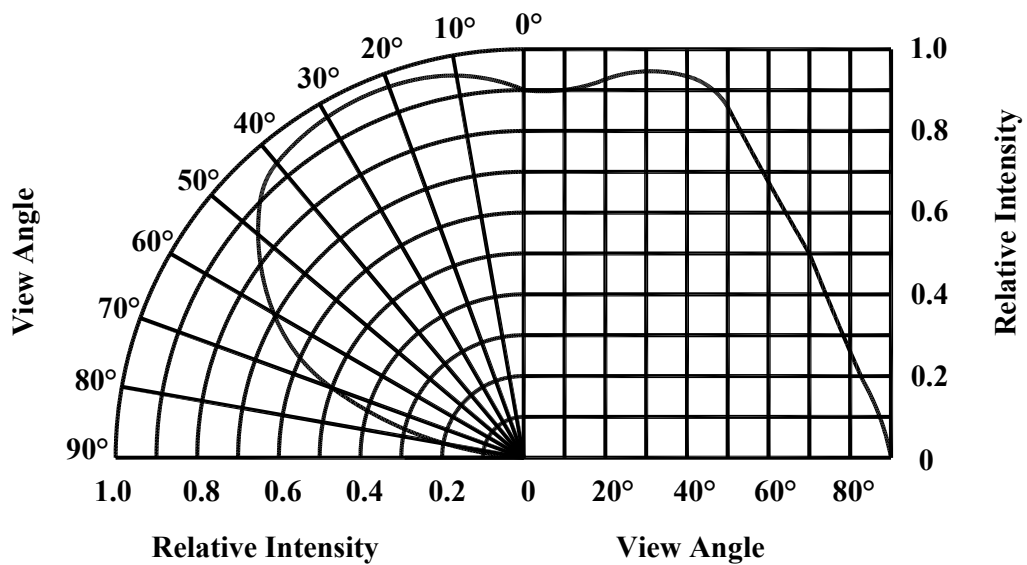

**Forward Current vs. Forward Voltage  $T_a=25^\circ\text{C}$**

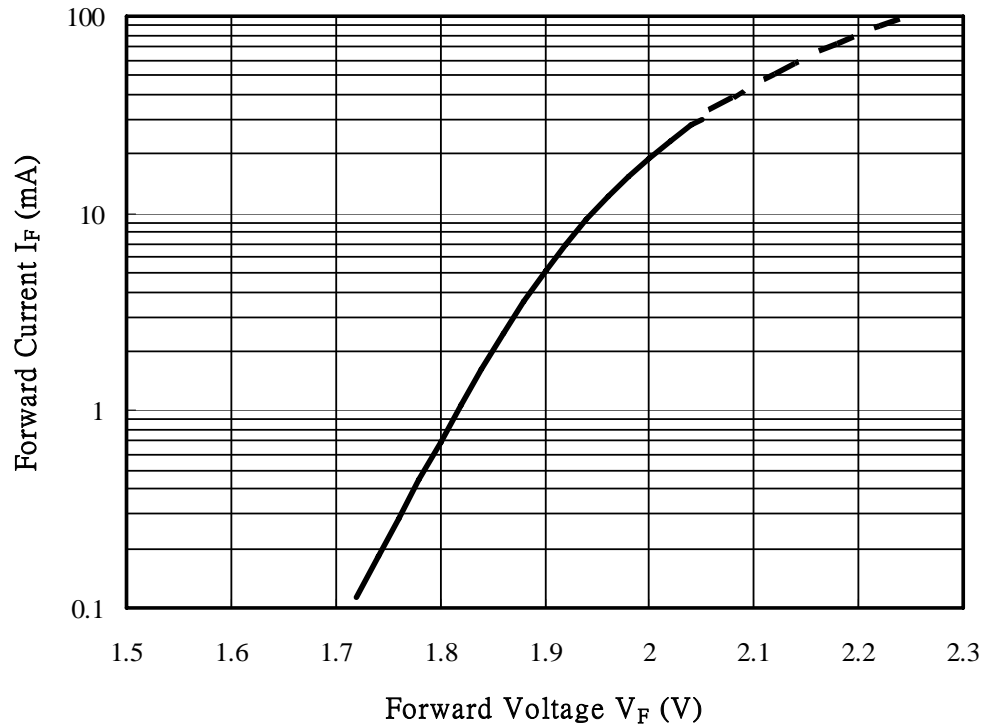

**Forward current vs. Ambient Temp.**

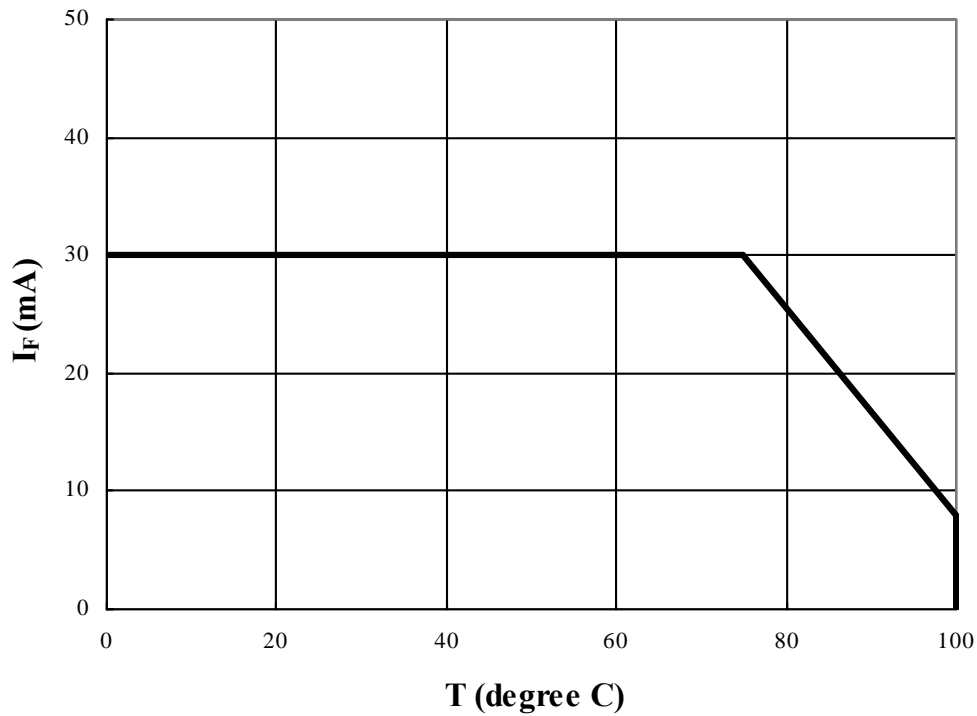

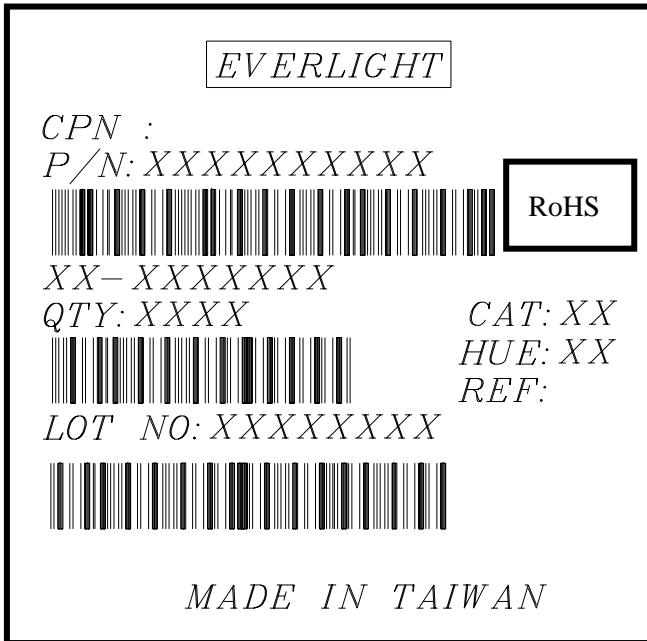

**Label explanation**

- CPN: Customer's Production Number
- P/N : Production Number
- QTY: Packing Quantity
- CAT: Ranks of Luminous Intensity
- HUE: Color Rank
- REF: Forward Voltage
- LOT No: Lot Number
- MADE IN TAIWAN: Production Place

**Reel Dimensions**

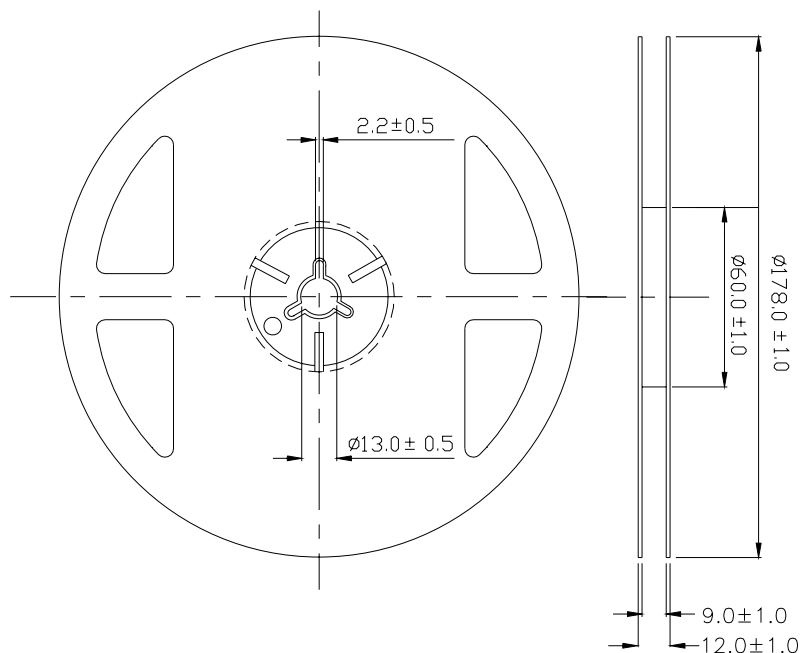

**Note:** The tolerances unless mentioned is ±0.1mm , Unit = mm



## Precautions For Use

### 1. Over-current-proof

Customer must apply resistors for protection, otherwise slight voltage shift will cause big current change ( Burn out will happen ).

### 2. Storage

2.1 Do not open moisture proof bag before the products are ready to use.

2.2 Before opening the package: The LEDs should be kept at 30°C or less and 90%RH or less.

2.3 After opening the package: The LED's floor life is 1 year under 30°C or less and 60% RH or less.

If unused LEDs remain, it should be stored in moisture proof packages.

2.4 If the moisture absorbent material (silica gel) has faded away or the LEDs have exceeded the storage time, baking treatment should be performed using the following conditions.

Baking treatment : 60±5°C for 24 hours.

### 3. Soldering Condition

#### 3.1 Pb-free solder temperature profile

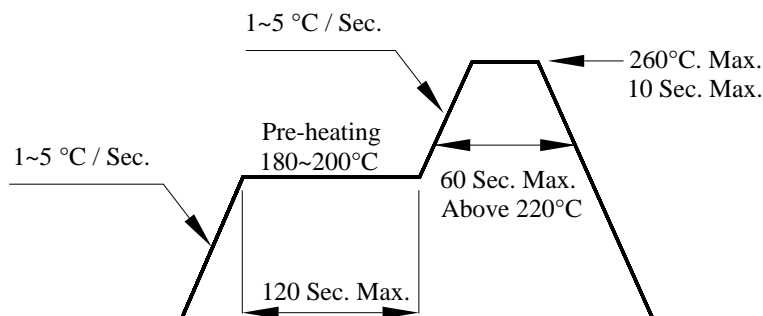

3.2 Reflow soldering should not be done more than two times.

3.3 When soldering, do not put stress on the LEDs during heating.

3.4 After soldering, do not warp the circuit board.

#### 4.Soldering Iron

Each terminal is to go to the tip of soldering iron temperature less than 350°C for 3 seconds within once in less than the soldering iron capacity 25W. Leave two seconds and more intervals, and do soldering of each terminal. Be careful because the damage of the product is often started at the time of the hand solder.

#### 5.Repairing

Repair should not be done after the LEDs have been soldered. When repairing is unavoidable, a double-head soldering iron should be used (as below figure). It should be confirmed beforehand whether the characteristics of the LEDs will or will not be damaged by repairing.

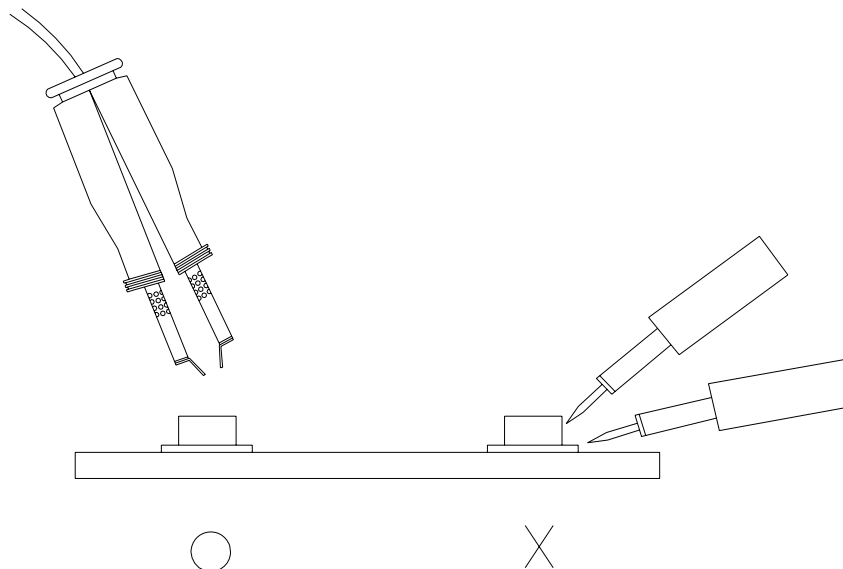

**EVERLIGHT ELECTRONICS CO., LTD.**  
Office: No 25, Lane 76, Sec 3, Chung Yang Rd,  
Tucheng, Taipei 236, Taiwan, R.O.C

Tel: 886-2-2267-2000, 2267-9936  
Fax: 886-2267-6244, 2267-6189, 2267-6306  
<http://www.everlight.com>

## Looking for pricing, stock, or lifecycle information?

Click below to explore more details on WIN SOURCE:

- [View 19-013/Y2SC-AQ2R2B/3T on WIN SOURCE](#)
- [Everlight Electronics Co Ltd Information](#)

## Optimize Your Supply Chain with WIN SOURCE Solutions

- ✓ Global Sourcing Solution
- ✓ Obsolete Management
- ✓ Cost Control Management
- ✓ Shortage Management
- ✓ Alternative Solution
- ✓ Excess Inventory Management