



**THE DATASHEET OF  
DXP2ABN7514TL**



**Micro Chip Transformer DXP2ABN7514T□ Reference Specification**

**1. Scope**

This reference specification applies to Micro Chip Transformer.

**2. Part Numbering**

- |       |           |          |           |          |          |           |           |          |          |
|-------|-----------|----------|-----------|----------|----------|-----------|-----------|----------|----------|
| (ex.) | <u>DX</u> | <u>P</u> | <u>2A</u> | <u>B</u> | <u>N</u> | <u>75</u> | <u>14</u> | <u>T</u> | <u>L</u> |
|       | (1)       | (2)      | (3)       | (4)      | (5)      | (6)       | (7)       | (8)      | (9)      |
- (1) Micro Chip Transformer
  - (2) Structure (P: Film Type)
  - (3) Dimension (L×W)
  - (4) Type of Transformer (B:Balun)
  - (5) Category
  - (6) Port Impedance (75 : 75ohm)
  - (7) Impedance ratio (14: one to four)
  - (8) Main Application ( T :50~870MHz)
  - (9) Packing Code L:Taping / B:Bulk

**3. Electrical Specification**

Customer Part Number	Murata Part Number	Freq. Range [MHz]	input-output Impedance [ohm]	Insertion Loss [dB]	CMRR [dB]	Return Loss [dB]	Rated Power [dBm]	DC Resistance
	DXP2ABN7514TL	50~870	75-300	1.8max.	20 min.	6min.	20	2.0Ω (typ.)
	DXP2ABN7514TB							

Operating Temperature : -40 to +85°C      Storage Temperature : -40 to +85°C

**4. Standard Testing Condition**

<Unless otherwise specified>  
 Temperature : Ordinary Temperature 15 to 35°C  
 Humidity : Ordinary Humidity 25 to 85%(RH)

<In case of doubt>  
 Temperature : 20 ± 2°C  
 Humidity : 60 to 70%(RH)  
 Atmospheric Pressure : 86 to 106kPa

**5. Style and Dimensions**

■ Dimension

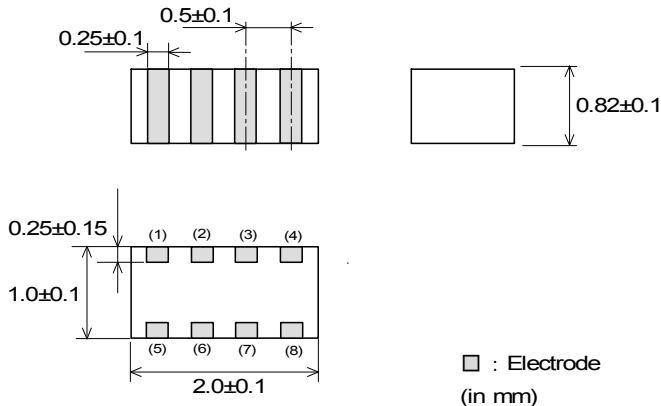

■ Equivalent Circuit

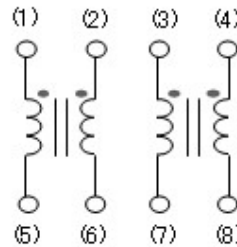

No polarity.

□ : Electrode  
(in mm)

■ Unit Mass(typ.)

0.008g

**6. Marking**

No Marking.

**7. Electrical Performance**

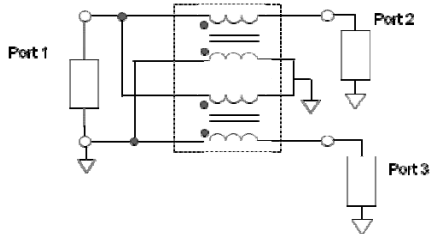
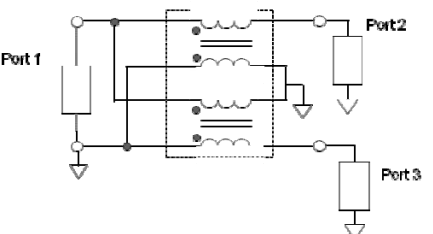
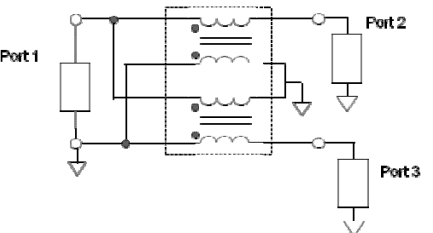
No.	Item	Specification	Definition and Measurement Method								
7.1	Insertion Loss (IL)	Meet item 3.	<p>Insertion Loss is given by Sds21 mag extracted from the below circuit. Parasitics and loss factors caused by the test board have to be removed.</p> <p style="text-align: center;">Port Impedance [ohm]</p> <table border="1" style="margin-left: auto; margin-right: auto;"> <tr> <th></th> <th>Port1</th> <th>Port2</th> <th>Port3</th> </tr> <tr> <td>7514T</td> <td style="text-align: center;">75</td> <td style="text-align: center;">150</td> <td style="text-align: center;">150</td> </tr> </table> <p>IL[dB] = 20log<sub>10</sub>(Sds21)                      Where                      Sds21 is S-parameter of single mode stimulus - Differential mode response</p> <div style="text-align: center;">  </div> <p style="text-align: right;">(Ref.10)</p>		Port1	Port2	Port3	7514T	75	150	150
	Port1	Port2	Port3								
7514T	75	150	150								
7.2	CMRR	Meet item 3.	<p>CMRR is given by the following equation, S-parameters are extracted from the below circuit. Parasitics and loss factors caused by the test board have to be removed.</p> <p style="text-align: center;">Port Impedance [ohm]</p> <table border="1" style="margin-left: auto; margin-right: auto;"> <tr> <th></th> <th>Port1</th> <th>Port2</th> <th>Port3</th> </tr> <tr> <td>7514T</td> <td style="text-align: center;">75</td> <td style="text-align: center;">150</td> <td style="text-align: center;">150</td> </tr> </table> <p>CMRR[dB] = 20log<sub>10</sub>(Sds21/Scs21)                      Where                      Sds21 is S-parameter of single mode stimulus - Differential mode response                      Scs21 is S-parameter of single mode stimulus - Common mode response</p> <div style="text-align: center;">  </div> <p style="text-align: right;">(Ref.10)</p>		Port1	Port2	Port3	7514T	75	150	150
	Port1	Port2	Port3								
7514T	75	150	150								
7.3	Return Loss (RL)	Meet item 3.	<p>Insertion Loss is given by Sss11 mag extracted from the below circuit. Parasitics and loss factors caused by the test board have to be removed.</p> <p style="text-align: center;">Port Impedance [ohm]</p> <table border="1" style="margin-left: auto; margin-right: auto;"> <tr> <th></th> <th>Port1</th> <th>Port2</th> <th>Port3</th> </tr> <tr> <td>7514T</td> <td style="text-align: center;">75</td> <td style="text-align: center;">150</td> <td style="text-align: center;">150</td> </tr> </table> <p>RL[dB] = 20log<sub>10</sub>(Sss11)                      Where                      Sss11 is S-parameter of single mode stimulus - Refletcion response</p> <div style="text-align: center;">  </div> <p style="text-align: right;">(Ref.10)</p>		Port1	Port2	Port3	7514T	75	150	150
	Port1	Port2	Port3								
7514T	75	150	150								

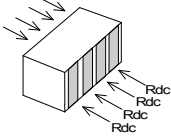
No.	Item	Specification	Definition and Measurement Method
7.4	DC Resistance (Rdc)	Meet item 3.	Measuring current : 80mA max.(ref.item 10.) 

**8. Mechanical Performance**

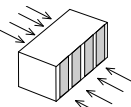
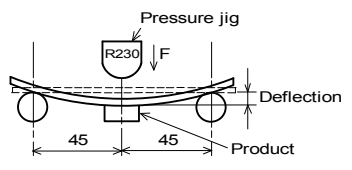

No.	Item	Specification	Test Method									
8.1	Appearance and Dimensions	Meet all dimension on item 5.	Visual Inspection and measurement with microscope.									
8.2	Solderability	The electrodes shall be at least 95% covered with new solder coating. 	Flux:Ethanol solution of rosin,25(wt)% Pre-Heating : 150±10°C 60s to 90s Solder : Sn-3.0Ag-0.5Cu Solder Temperature : 245±5°C Immersion Time : 3±1 seconds Immersion and emersion rates : 25mm/s									
8.3	Resistance to Soldering Heat	Meet Table 1. <table border="1" style="width: 100%; border-collapse: collapse;"> <thead> <tr> <th colspan="2">Table 1</th> </tr> </thead> <tbody> <tr> <td style="width: 50%;">Appearance</td> <td>No damaged</td> </tr> <tr> <td>IL</td> <td rowspan="2">Meet Item 3.</td> </tr> <tr> <td>CMRR</td> </tr> <tr> <td>Return Loss</td> <td></td> </tr> </tbody> </table>	Table 1		Appearance	No damaged	IL	Meet Item 3.	CMRR	Return Loss		Flux : Ethanol solution of rosin,25(wt)% Pre-Heating : : 150±10°C 60s Solder : Sn-3.0Ag-0.5Cu Solder Temperature : 270±5°C Immersion Time : 10±1 seconds Immersion and emersion rates : 25mm/s Then measured after exposure in the room condition for 4 to 48 hours.
Table 1												
Appearance	No damaged											
IL	Meet Item 3.											
CMRR												
Return Loss												
8.4	Drop		It shall be dropped on concrete or steel board. Method : free fall Height : 1 m The Number of Times : 10 times									
8.5	Vibration		It shall be soldered on the substrate. Oscillation Frequency : 10 to 2000 to 10Hz <div style="text-align: right;">for 20 minutes</div> Total Amplitude 3.0mm or Acceleration 196m/s <sup>2</sup> <div style="text-align: right;">whichever is smaller</div> Testing Time : A period of 2 hours in each of 3 mutually perpendicular directions. (Total 6 hours)									
8.6	Bending Strength	Meet Table 2. <table border="1" style="width: 100%; border-collapse: collapse;"> <thead> <tr> <th colspan="2">Table 2</th> </tr> </thead> <tbody> <tr> <td style="width: 50%;">Appearance</td> <td>No damaged</td> </tr> <tr> <td>DC Resistance Change</td> <td>within ± 30%</td> </tr> </tbody> </table>	Table 2		Appearance	No damaged	DC Resistance Change	within ± 30%	It shall be soldered on the Glass-epoxy substrate. Deflection : 2mm (t=1.0mm). Keeping time : 30s Speed of Applying Force : 0.5mm/s  <div style="text-align: right;">(in mm)</div>			
Table 2												
Appearance	No damaged											
DC Resistance Change	within ± 30%											

**9. Environmental Performance**(Products shall be soldered on the substrate.)

No.	Item	Specification	Test Method
9.1	Heat Shock	Meet Table 1.	1 Cycle Step 1 -40°C(+0°C,-3°C) / 30(+3,-0) min Step 2 +85(+3°C,-0°C) / 30(+3,-0) min Total of 200 cycles. Then measured after exposure in the room condition for 4 to 48 hours.
9.2	Humidity		Temperature : 40±2°C Humidity : 90~95%(RH) Time : 1000(+48 hours,-0 hours) Then measured after exposure in the room condition for 4 to 48 hours.
9.3	Heat Resistance		Temperature : 85±2°C Time : 1000(+48 hours,-0 hours) Then measured after exposure in the room condition for 4 to 48 hours.
9.4	Cold Resistance		Temperature : -40± 2°C Time : 1000(+48 hours,-0 hours) Then measured after exposure in the room condition for 4 to 48 hours.

**10. Terminal to be Tested.**

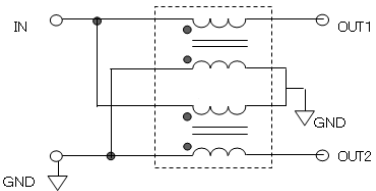
When measuring and suppling the voltage,the following terminal is applied.

No.	Item	Terminal to be Tested
10.1	Insertion Loss (IL) CMRR Return Loss (RL) (Measurement Terminal)	
10.2	DC Resistance (Measurement Terminal)	

**11. P.C.B., Flux, Solder and Soldering condition**

Test shall be done using P.C.B., Flux, Solder and Soldering condition which are specified in item 16 except the case of being specified special condition.

## 12. Frequency Characteristics (Typ.)

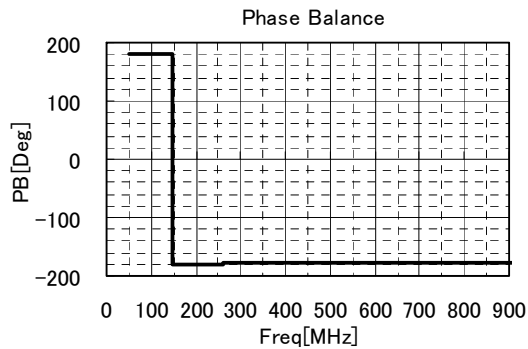
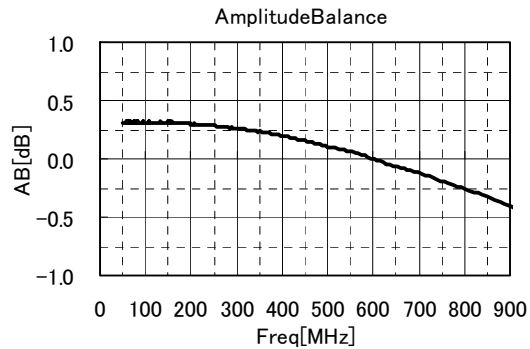
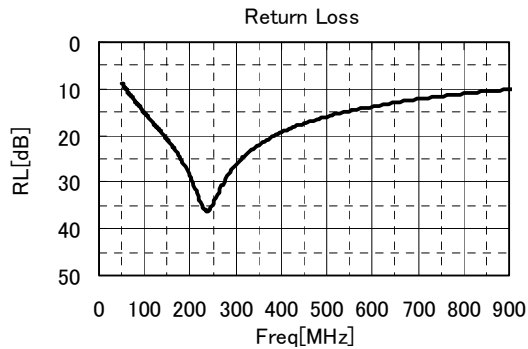
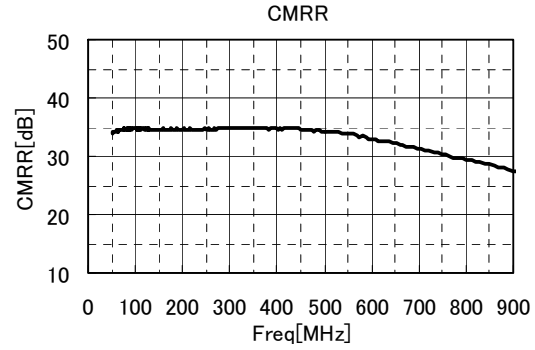
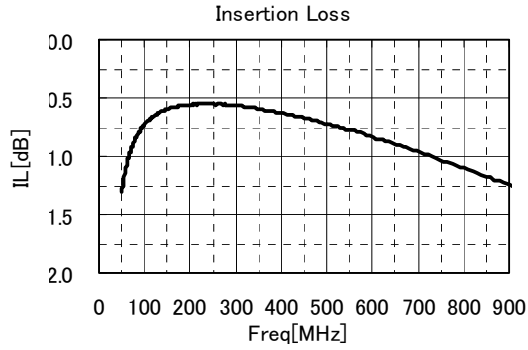

## 13. Specification of Packaging

### 13.1 Appearance and Dimensions (8mm-wide, Plastic tape)

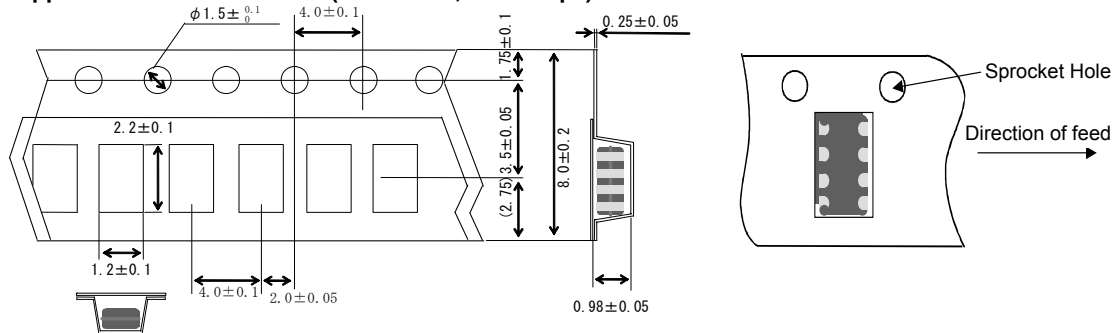

### 13.2 Specification of Taping

- (1) Packing quantity (Standard quantity) 3000 pcs. / reel
- (2) Packing Method  
Products shall be packaged in each embossed cavity of plastic tape and sealed with cover tape.
- (3) Sprocket Hole  
Sprocket hole shall be located on the left hand side toward the direction of feed.
- (4) Spliced point  
The cover tape have no spliced point.
- (5) Missing components number  
Missing components number within 0.1% of the number per reel or 1 pc., whichever is greater, and are not continuous. The specified quantity per reel is kept.

### 13.3 Pull Strength of Plastic Tape

Plastic Tape	5N min.
Cover Tape	10N min.

### 13.4 Peeling off force of Cover Tape

0.2 to 0.7N (Minimum value is Typical)  
Speed of Peeling off : 300 mm/min.

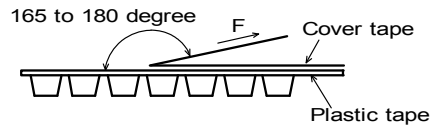

### 13.5 Dimensions of Leader-tape, Trailer and Reel

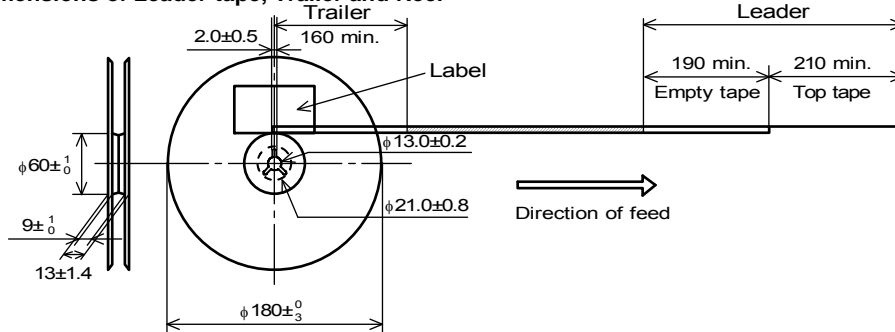

### 13.6 Marking for reel

Customer part number, MURATA part number, Inspection number(\*1), RoHS Marking(\*2), Quantity, etc

\*1) « Expression of Inspection No. »

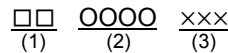

- (1) Factory Code
- (2) Date

First digit : Year / Last digit of year  
Second digit : Month / Jan. to Sep. → 1 to 9, Oct. to Dec. → O,N,D  
Third, Fourth digit : Day

- (3) Serial No.

\*2) « Expression of RoHS Marking »

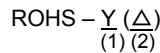

- (1) RoHS regulation conformity parts.
- (2) MURATA classification number

### 13.7 Marking for Outside package

Customer name Purchasing Order Number, Customer Part Number, MURATA part number, RoHS Marking (\*2), Quantity, etc

### 13.8 Specification of Outer Case

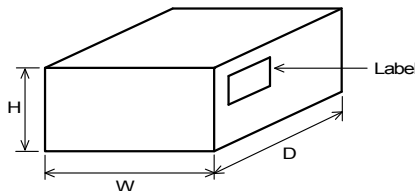

Outer Case Dimensions (mm)			Standard Reel Quantity in Outer Case (Reel)
W	D	H	
186	186	93	5

\* Above Outer Case size is typical. It depends on a quantity of an order.

**14. ⚠ Caution**

**14.1 Mounting Direction**

Mount products in right direction.  
 Wrong direction which is 90° rotated from right direction causes not only open or short circuit but also flames or other serious trouble.

**14.2 Limitation of Application**

Please contact us before using our products for the applications listed below which require especially high reliability for the prevention of defects which might directly cause damage to the third party's life, body or property.

- |                                   |   |
|-----------------------------------|---|
| (1) Aircraft equipment            | (6) Transportation equipment (vehicles, trains, ships, etc.)  |
| (2) Aerospace equipment           | (7) Traffic signal equipment  |
| (3) Undersea equipment            | (8) Disaster prevention / crime prevention equipment  |
| (4) Power plant control equipment | (9) Data-processing equipment   |
| (5) Medical equipment             | (10) Applications of similar complexity and / or reliability to the applications listed in the above. |

**15. Notice**

Products can only be soldered with reflow.  
 This product is designed for solder mounting.  
 Please consult us in advance for applying other mounting method such as conductive adhesive.

**15.1 Flux and Solder**

Flux	Use rosin-based flux, but not highly acidic flux (with chlorine content exceeding 0.2(wt)%.) Do not use water-soluble flux.
Solder	Use Sn-3.0Ag-0.5Cu solder Use of Sn-Zn based solder will deteriorate performance of products. In case of using Sn-Zn based solder, please contact Murata in advance.

**15.2 Assembling**

<Thermal Shock>

Pre-heating should be in such a way that the temperature difference between solder and ceramic surface is limited to 100°C MAX. Also cooling into solvent after soldering should be in such a way that the temperature difference is limited to 100°C max.

**15.3 Resin coating**

The electric characteristics may change and/or it may affect on the product's performance due to high cure-stress of resin to be used for coating / molding products. So please pay your careful attention when you select resin. In prior to use, please make the reliability evaluation with the product mounted in your application set.

**15.4 Attention regarding P.C.B. bending**

The following shall be considered when designing and laying out P.C.B.'s.

- (1) P.C.B. shall be designed so that products are not subject to the mechanical stress due to warping the board.

[Products direction]

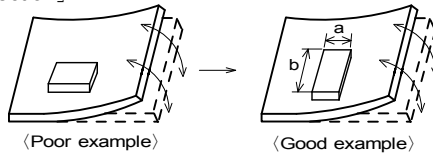

Products shall be location the sideways Direction (Length : a<b) to the mechanical Stress.

[Wrapping direction]

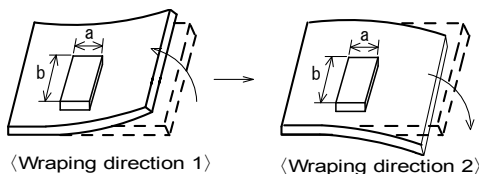

Products(wrapping direction 1, wrapping direction 2) shall be located carefully so that products are not subject to the mechanical stress due to warping the board. Because they may be subjected the mechanical stress in order of wrapping direction 1>wrapping direction 2.

(2) Products location on P.C.B. separation  
 Products(A,B,C,D) shall be located carefully so that products are not subject to the mechanical stress due to warping the board. Because they may be subjected the mechanical stress in order of  $A > C > B \cong D$ .

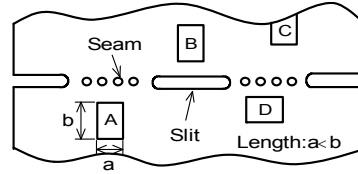

### 15.5 Attention Regarding P.C.B. Design

#### < The Arrangement of Products >

P.C.B. shall be designed so that products are far from the portion of perforation.

The portion of perforation shall be designed as narrow as possible and shall be designed so as not to be applied the stress in the case of P.C.B. separation.

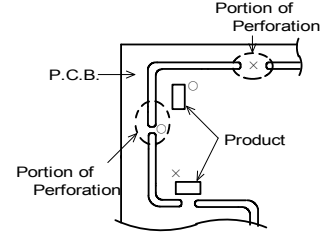

Products shall not be arranged on the line of a series of holes when there are big holes in P.C.B. (Because the stress concentrate on the line of holes.)

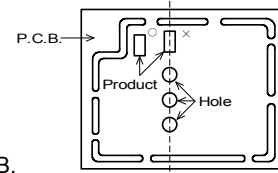

#### < Products Placing >

Support pins shall be set under P.C.B. to prevent causing a warp to P.C.B. during placing the products on the other side of P.C.B.

#### < P.C.B. Separation >

P.C.B. shall not be separated with hand.  
 P.C.B. shall be separated with the fixture so as not to cause P.C.B. bending.

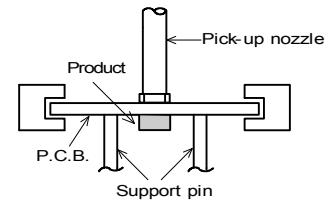

### 15.6 Attention Regarding P.C.B. Mounting

In case of mounting by use of mounting machine, please choose nozzle which can pick up components of 2012 size or the equivalents.

### 15.7 Standard Land Dimensions

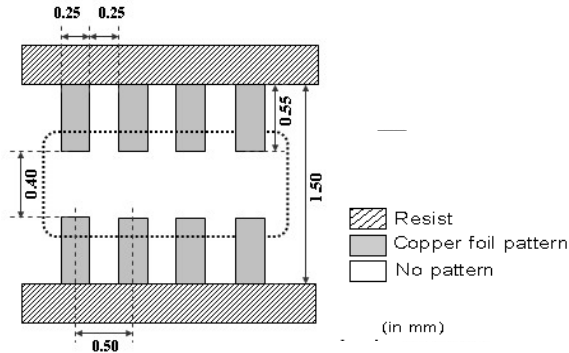

**15.8 Standard Soldering Condition**

(1) Soldering Condition

Standard soldering profile and the limit soldering profile is as follows.

The excessive limit soldering conditions may cause leaching of the electrode and / or resulting in the deterioration of product quality.

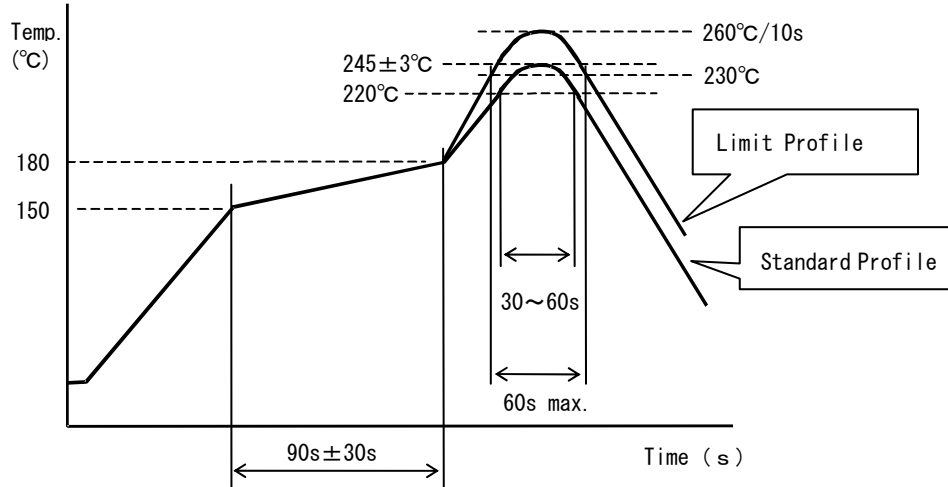

	Standard Profile	Limit Profile
Pre-heating	150~180°C、90s±30s	
Heating	above 220°C、30s~60s	above 230°C、60s max.
Peak temperature	245±3°C	260°C、10s
Cycle of reflow	2 times	2 times

(2) Standard printing pattern of solder paste

- Standard thickness of the solder paste should be 100 to 150µm.
- Use the solder paste printing pattern of the right pattern.
- For the resist and copper foil pattern, use standard land dimensions.
- Use Sn-3.0Ag-0.5Cu solder.

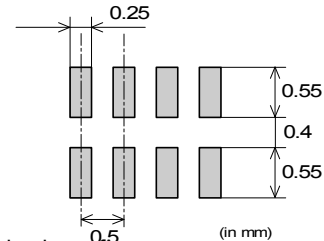

(3) Reworking with Soldering iron

- The following conditions shall be strictly followed when using a soldering iron after being mounted by reflow soldering.
  - Pre-heating: 150°C, 1 min
  - Soldering iron output: 30W max.
  - Tip temperature: 380°C max.
  - Tip diameter: φ3mm max.
  - Soldering time : 3(+1,-0) seconds.
  - Times : 2times max.
- Do not touch the products directly with the tip of the soldering iron.

(4) Solder Volume

Solder shall be used not to be exceeded the upper limits as shown below.

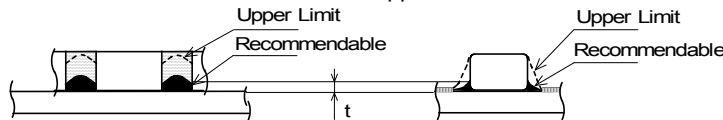

$$1/3T \leq t \leq T \quad (T: \text{Chip thickness})$$

Accordingly increasing the solder volume, the mechanical stress to product is also increased. Excessive solder volume may cause the failure of mechanical or electrical performance.

**15.9 Cleaning Conditions**

Products shall be cleaned on the following conditions.

- (1) Cleaning temperature shall be limited to 60°C max. (40°C max. for Isopropyl alcohol.)
- (2) Ultrasonic cleaning shall comply with the following conditions, avoiding the resonance phenomenon at the mounted products and P.C.B..
  - Power : 20W/l max.    · Frequency : 28kHz to 40kHz    · Time : 5 minutes max.
- (3) Cleaner
  1. Alternative cleaner    · Isopropyl alcohol (IPA)
  2. Aqueous agent        · PINE ALPHA ST-100S
- (4) There shall be no residual flux and residual cleaner after cleaning.  
In the case of using aqueous agent, products shall be dried completely after rinse with de-ionized water in order to remove the cleaner.
- (5) Other cleaning  
Please contact us.

**15.10 Handling of a substrate**

After mounting products on a substrate, do not apply any stress to the product caused by bending or twisting to the substrate when cropping the substrate, inserting and removing a connector from the substrate or tightening screw to the substrate.

Excessive mechanical stress may cause cracking in the product.

Bending

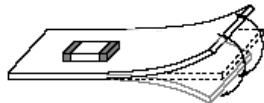

Twisting

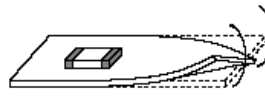
**15.11 Operating Environment**

Do not use this product under the following environmental conditions, on deterioration of the performance, such as insulation resistance may result from the use.

- (1) in corrosive gases (acidic gases, alkaline gases, chlorine, sulfur gases, organic gases and etc.)
- (2) in the atmosphere where liquid such as organic solvent, may splash on the products.

**15.12 Storage Condition****(1) Storage period**

Use the products within 12 months after delivered.

Solderability should be checked if this period is exceeded.

**(2) Storage environment conditions**

· Products should be stored in the warehouse on the following conditions.

Temperature : -10 ~ +40°C

Humidity : 15 to 85% relative humidity No rapid change on temperature and humidity.

- Products should not be stored in corrosive gases, such as sulfurous, acid gases, alkaline gases, to prevent the following deterioration. Poor solderability due to the oxidized electrode.
- Products should be stored on the palette for the prevention of the influence from humidity, dust and so on.
- Products should be stored in the warehouse without heat shock, vibration, direct sunlight and so on.
- Products should not be stored under the air tight packaged condition.

**(3) Delivery**



Care should be taken when transporting or handling product to avoid excessive vibration or mechanical shock.

**16.  Note**

- (1) Please make sure that your product has been evaluated in view of your specifications with our product being mounted to your product.
- (2) You are requested not to use our product deviating from the reference specifications.
- (3) The contents of this reference specification are subject to change without advance notice. Please approve our product specifications or transact the approval sheet for product specifications before ordering.

## Looking for pricing, stock, or lifecycle information?

Click below to explore more details on WIN SOURCE:

-  [View DXP2ABN7514TL on WIN SOURCE](#)
-  [Murata Electronics North America Information](#)

## Optimize Your Supply Chain with WIN SOURCE Solutions

-  Global Sourcing Solution
-  Obsolete Management
-  Cost Control Management
-  Shortage Management
-  Alternative Solution
-  Excess Inventory Management