



**THE DATASHEET OF
DSC1001CI1-033.3330**





1.8~3.3V

Low-Power Precision CMOS Oscillator

General Description

The DSC1001 is a silicon MEMS based CMOS oscillator offering excellent jitter and stability performance over a wide range of supply voltages and temperatures. The device operates from 1 to 150MHz with supply voltages between 1.8 to 3.3 Volts and temperature ranges up to -40°C to 105°C.

The DSC1001 incorporates an all silicon resonator that is extremely robust and nearly immune to stress related fractures, common to crystal based oscillators. Without sacrificing the performance and stability required of today's systems, a crystal-less design allows for a higher level of reliability, making the DSC1001 ideal for rugged, industrial, and portable applications where stress, shock, and vibration can damage quartz crystal based systems.

Available in industry standard packages, the DSC1001 can be "dropped-in" to the same PCB footprint as standard crystal oscillators.

Block Diagram

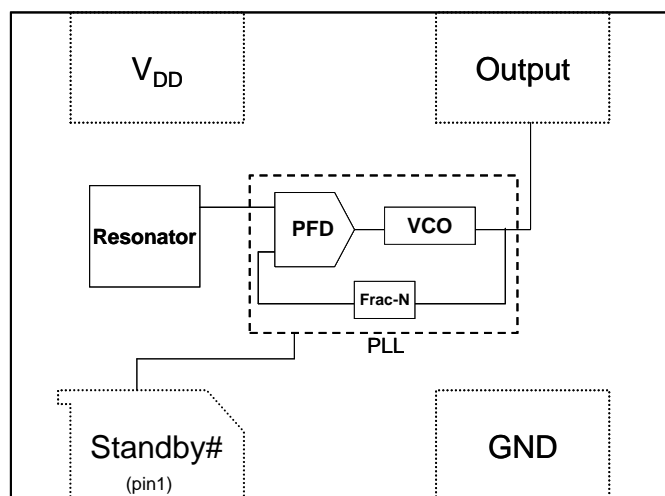

Features

- Frequency Range: 1 to 150MHz
- Exceptional Stability over Temperature
 - ± 10 PPM, ± 25 PPM, ± 50 PPM
- Operating voltage
 - 1.7 to 3.6V
- Operating Temperature Range
 - Ext. Industrial -40°C to 105°C
 - Industrial -40°C to 85°C
 - Ext. Commercial -20°C to 70°C
 - Commercial 0°C to 70°C
- Low Operating and Standby Current
 - 5mA Operating (40MHz)
 - 15uA Standby
- Ultra Miniature Footprint
 - 2.5 x 2.0 x 0.85 mm
 - 3.2 x 2.5 x 0.85 mm
 - 5.0 x 3.2 x 0.85 mm
 - 7.0 x 5.0 x 0.85 mm
- MIL-STD 883 Shock and Vibration Resistant
- Pb Free, RoHS, Reach SVHC Compliant
- AEC-Q100 Reliability Qualified

Benefits

- Pin for pin "drop in" replacement for industry standard oscillators
- Semiconductor level reliability, significantly higher than quartz
- Short mass production lead-times
- Longer Battery Life / Reduced Power
- Compact Plastic package
- Cost Effective

Applications

- Mobile Applications
- Consumer Electronics
- Portable Electronics
- DVR, CCTV, Surveillance Cameras
- Low Profile Applications
- Industrial Applications

Absolute Maximum Ratings¹

Item	Min	Max	Unit	Condition
Input Voltage	-0.3	V _{DD} +0.3	V	
Junction Temp	-	+150	°C	
Storage Temp	-55	+150	°C	
Soldering Temp	-	+260	°C	40 sec max.
ESD	-		V	
HBM		4000		
MM		200		
CDM		1500		

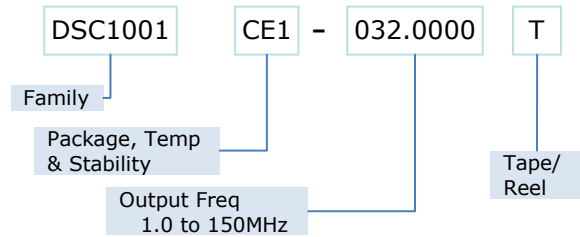

* See Ordering Information for details

Ordering Code

Recommended Operating Conditions

Parameter	Symbol	Range
Supply Voltage	V _{DD}	1.7 – 3.6V
Output Load	Z _L	R>10KΩ, C≤15pF
Operating Temperature		
Option 1		-40 to +105 °C
Option 2	T	-40 to +85 °C
Option 3		-20 to +70 °C
Option 4		0 to +70 °C

Specifications (V_{DD} = 1.8 to 3.3v) T_A=85°C unless otherwise specified

Parameter	Symbol	Condition	Min	Typ	Max	Unit
Frequency	f ₀	Single Frequency	1		150	MHz
Frequency Tolerance	Δf	Includes frequency variations due to initial tolerance, temperature and power supply voltage			±10,±25,±50	ppm
Aging	Δf1	First year @25°C	-5		+5	ppm
	Δf2	Per year after 1 st year @25°C	-1		+1	ppm
Supply Current, standby	I _{DD}	T=25°C			15	uA
Output Logic Levels						
Output logic high	V _{OH}	-4mA	0.8*V _{DD}		-	Volts
Output logic low	V _{OL}	4mA	-		0.2*V _{DD}	
Startup Time ²	t _{SU}	90% V _{DD} to stable clock output		1.0	1.5	ms
Output Disable Time	t _{DA}	See Output Waveform for more detail		20	100	ns
Output Enable Time ²	t _{EN}	See Output Waveform for more detail		1.0	1.5	ms
Output Duty Cycle	SYM		45		55	%
Input Logic Levels						
Input logic high	V _{IH}		0.75*V _{DD}		-	Volts
Input logic low	V _{IL}		-		0.25* V _{DD}	

VDD = 1.8v

Parameter	Symbol	Condition		Min	Typ	Max	Unit
Supply Current, no load	I_{DD}	$C_L=0p$ $R_L=\infty$ $T=25^\circ C$	1MHz		6.0	6.3	mA
			27MHz		6.5	6.9	
			70MHz		7.2	7.5	
			150MHz		8.3	9.1	
Output Transition time Rise Time Fall Time	t_R	$C_L=15pF; T=25^\circ C$ $20\%/80\%*V_{DD}$			1.8	3	ns
	t_F				1.0	3	
Jitter, Max Cycle to Cycle	J_{CC}	$F = 100MHz^3$			60		Ps

VDD = 2.5v

Parameter	Symbol	Condition		Min	Typ	Max	Unit
Supply Current, no load	I_{DD}	$C_L=0p$ $R_L=\infty$ $T=25^\circ C$	1MHz		6.0	6.3	mA
			27MHz		6.7	7.0	
			70MHz		7.7	8.1	
			150MHz		9.6	10.6	
Output Transition time Rise Time Fall Time	t_R	$C_L=15pF; T=25^\circ C$ $20\%/80\%*V_{DD}$			1.0	2	ns
	t_F				0.9	2	
Jitter, Max Cycle to Cycle	J_{CC}	$F = 100MHz^3$			50		ps

VDD = 3.3v

Parameter	Symbol	Condition		Min	Typ	Max	Unit
Supply Current, no load	I_{DD}	$C_L=0p$ $R_L=\infty$ $T=25^\circ C$	1MHz		6.0	6.3	mA
			27MHz		6.8	7.2	
			70MHz		8.2	8.7	
			150MHz		10.8	12.2	
Output Transition time Rise Time Fall Time	t_R	$C_L=15pF; T=25^\circ C$ $20\%/80\%*V_{DD}$			1.0	2	ns
	t_F				0.9	2	
Jitter, Max Cycle to Cycle	J_{CC}	$F = 100MHz^3$			50		ps

Notes:

1. Absolute maximum ratings are those values beyond which the safety of the device cannot be guaranteed. The device should not be operated beyond these limits.
2. t_{SU} is time to stable output frequency after V_{DD} is applied. t_{SU} and t_{EN} (after Standby# is asserted high) are identical values.
3. Measured over 50k clock cycles.

Nominal Performance Characteristics

Supply Current

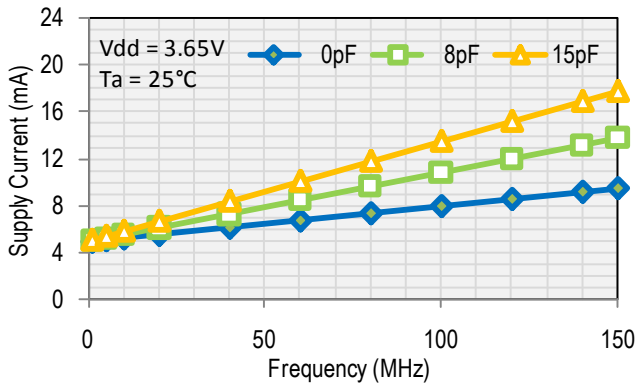

Supply Current

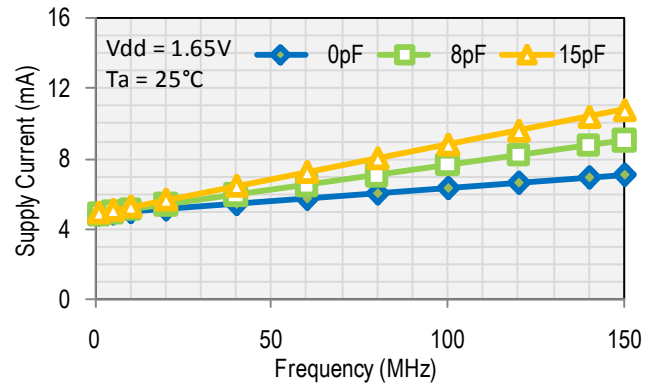

Rise Time

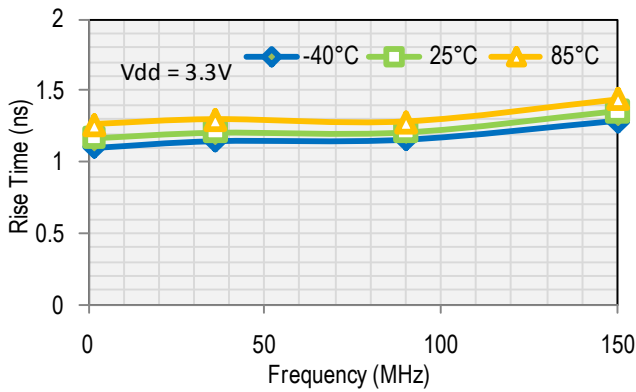

Fall Time

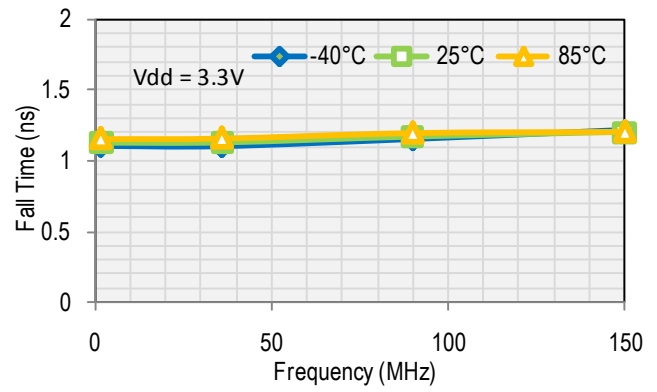

Rise Time

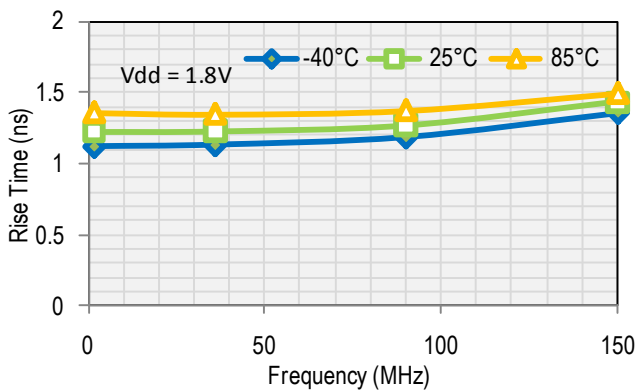

Fall Time

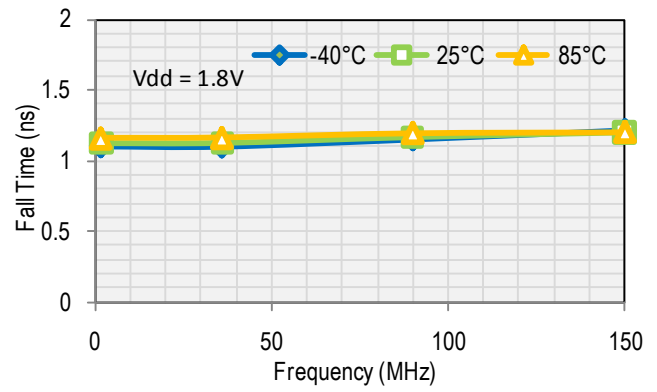

Output Waveform

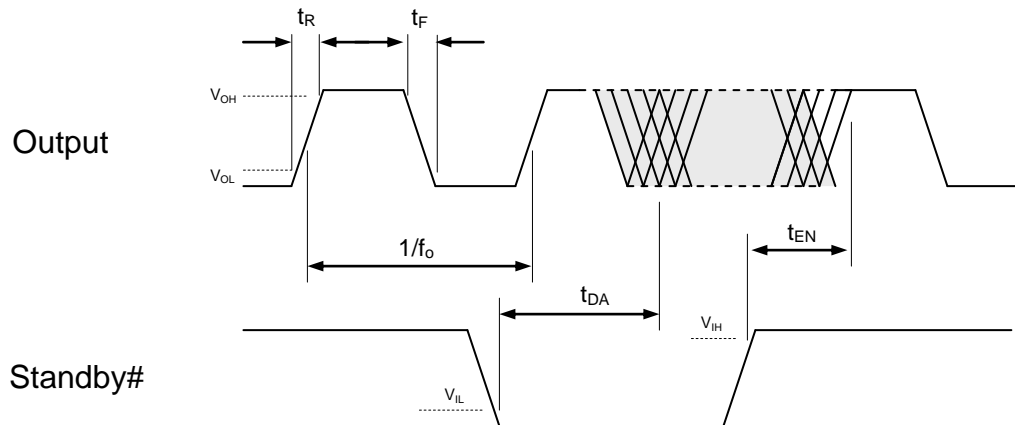

Standby Function

Standby# (pin 1)	Output (pin 3)
Hi Level	Output ON
Open (no connect)	Output ON
Low Level	High Impedance

Test Circuit

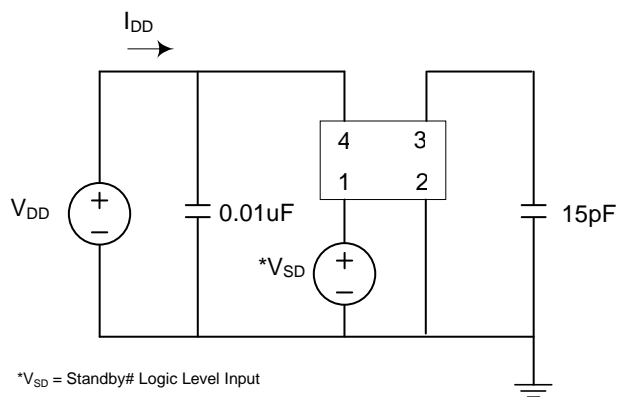

Board Layout (recommended)

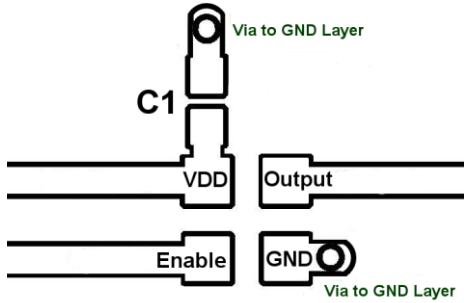

Solder Reflow Profile

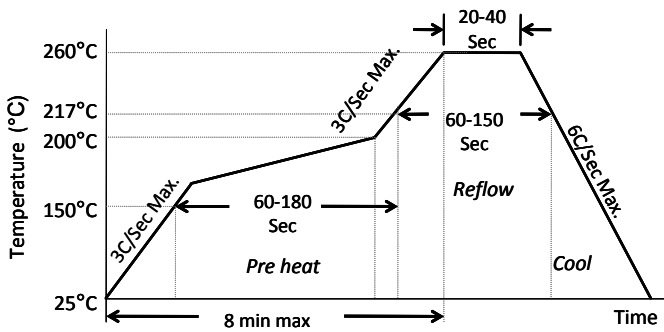

MSL 1 @ 260°C refer to JSTD-020C	
Ramp-Up Rate (200°C to Peak Temp)	3°C/Sec Max.
Preheat Time 150°C to 200°C	60-180 Sec
Time maintained above 217°C	60-150 Sec
Peak Temperature	255-260°C
Time within 5°C of actual Peak	20-40 Sec
Ramp-Down Rate	6°C/Sec Max.
Time 25°C to Peak Temperature	8 min Max.

Package Dimensions

7.0 x 5.0 mm Plastic Package

External Dimensions

Recommended Land Pattern*

No.	Pin Terminal
1	Standby#
2	GND
3	Output
4	VDD

units: mm [inch]

*Note: The center pad is not connected internally and should be left unconnected or tied to GND.

5.0 x 3.2 mm Plastic Package

External Dimensions

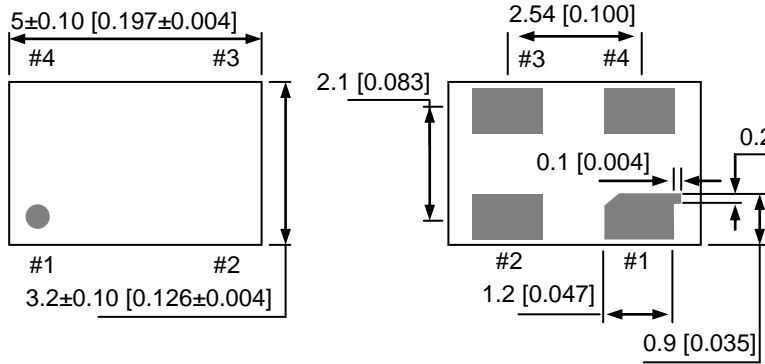

No.	Pin Terminal
1	Standby#
2	GND
3	Output
4	VDD

Recommended Land Pattern

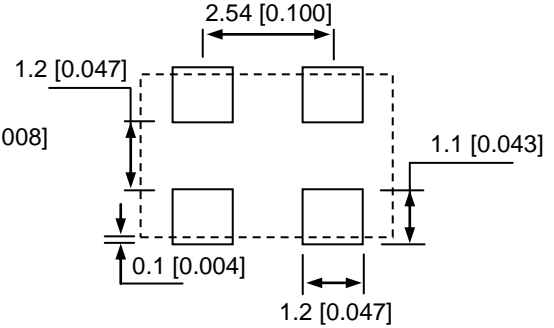

units: mm [inch]

3.2 x 2.5 mm Plastic Package

External Dimensions

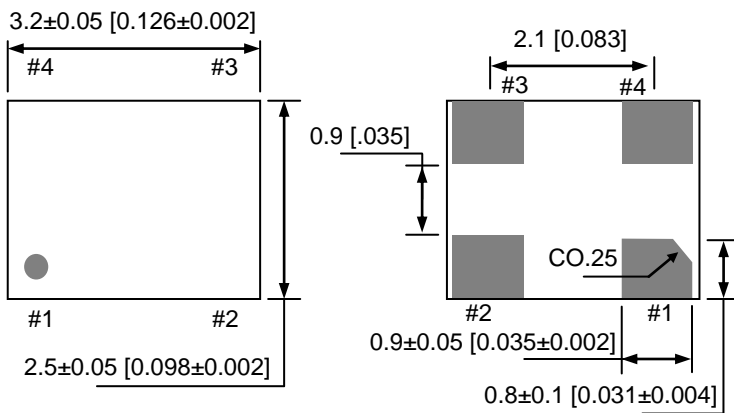

No.	Pin Terminal
1	Standby#
2	GND
3	Output
4	VDD

Recommended Land Pattern

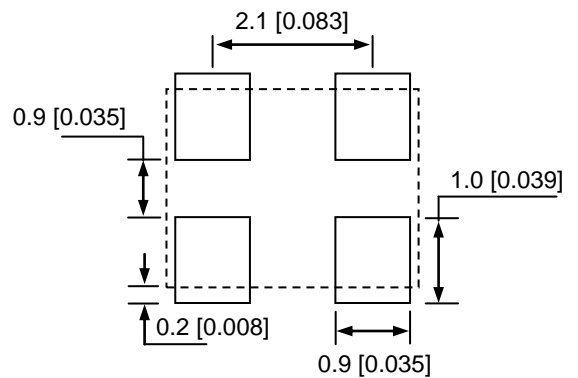

units: mm [inch]

2.5 x 2.0 mm Plastic Package

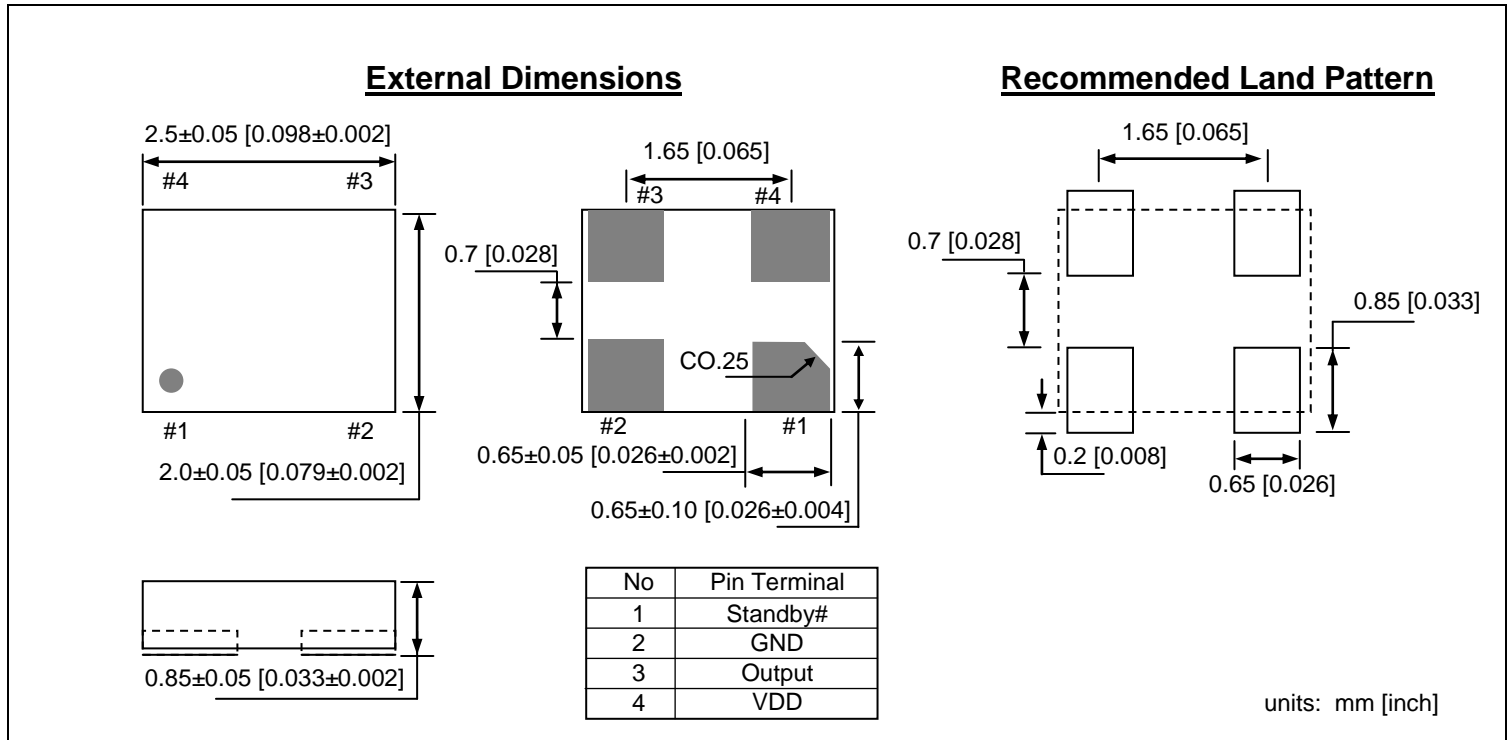

Ordering Information

DSC1001 PTS – xxx.xxxx T

PART NUMBERING GUIDE				
Package (Plastic QFN)	Temperature	Stability	Frequency	Packing Option
P=A: 7.0x5.0mm P=B: 5.0x3.2mm P=C: 3.2x2.5mm P=D: 2.5x2.0mm	T=C: 0° ~ +70° C T=E: -20° ~ +70° C T=I: -40° ~ +85° C T=L: -40° ~ +105° C	S=1: ±50ppm S=2: ±25ppm S=5: ±10ppm	xxx.xxxx	Blank: Tubes T: Tape & Reel

Example: DSC1001CE1-123.0000T

The example part number above is a 123.0000MHz oscillator in Plastic 3.2x2.5mm package, with ±50ppm stability over an operating temperature of -20 to +70°C, shipped in Tape and Reel.

Disclaimer:

Micrel makes no representations or warranties with respect to the accuracy or completeness of the information furnished in this data sheet. This information is not intended as a warranty and Micrel does not assume responsibility for its use. Micrel reserves the right to change circuitry, specifications and descriptions at any time without notice. No license, whether express, implied, arising by estoppel or otherwise, to any intellectual property rights is granted by this document. Except as provided in Micrel's terms and conditions of sale for such products, Micrel assumes no liability whatsoever, and Micrel disclaims any express or implied warranty relating to the sale and/or use of Micrel products including liability or warranties relating to fitness for a particular purpose, merchantability, or infringement of any patent, copyright or other intellectual property right.

Micrel Products are not designed or authorized for use as components in life support appliances, devices or systems where malfunction of a product can reasonably be expected to result in personal injury. Life support devices or systems are devices or systems that (a) are intended for surgical implant into the body or (b) support or sustain life, and whose failure to perform can be reasonably expected to result in a significant injury to the user. A Purchaser's use or sale of Micrel Products for use in life support appliances, devices or systems is a Purchaser's own risk and Purchaser agrees to fully indemnify Micrel for any damages resulting from such use or sale.

MICREL, Inc.
Phone: +1 (408) 944-0800

•

2180 Fortune Drive,
Fax: +1 (408) 474-1000

San Jose, California 95131
• Email: hbwhelp@micrel.com

•

USA
www.micrel.com

Mouser Electronics

Authorized Distributor

Click to View Pricing, Inventory, Delivery & Lifecycle Information:

Microchip:

[DSC1001BI1-001.8432T](#) [DSC1001CL1-008.0000T](#) [DSC1001DL5-012.2880T](#) [DSC1001CI1-024.0000](#) [DSC1001CE2-024.0000T](#) [DSC1001DI2-048.0000T](#) [DSC1001AI2-032.7680T](#) [DSC1001AE2-054.0000T](#) [DSC1001DE2-024.0000T](#) [DSC1001DE2-027.0000T](#) [DSC1001DE1-012.0000T](#) [DSC1001DE1-013.0000T](#) [DSC1001CI2-008.0000T](#) [DSC1001CI2-080.0000T](#) [DSC1001CI5-004.9152](#) [DSC1001CI1-004.0000T](#) [DSC1001DI2-025.0000T](#) [DSC1001DI1-024.0000](#) [DSC1001DI1-024.0000T](#) [DSC1001DI1-025.0000T](#) [DSC1001BL5-066.0000T](#) [DSC1001BL5-004.0000T](#) [DSC1001BI5-080.0000T](#) [DSC1001BI1-020.0000T](#) [DSC1001AI2-002.0480T](#) [DSC1001AI2-125.0000T](#) [DSC1001AE1-054.0000T](#) [DSC1001AI1-013.1072T](#) [DSC1001AC1-008.0000T](#) [DSC1001AI2-033.3330T](#) [DSC1001DI2-033.3333T](#) [DSC1001DI2-066.0000T](#) [DSC1001DI2-012.2880T](#) [DSC1001DI2-064.0000T](#) [DSC1001CI5-029.4912T](#) [DSC1001CI2-074.1750T](#) [DSC1001BL5-100.0000T](#) [DSC1001BL5-120.0000T](#) [DSC1001CE2-001.8432T](#) [DSC1001AI1-066.0000T](#) [DSC1001BI1-033.0000T](#) [DSC1001BI2-007.3728T](#) [DSC1001AI5-024.0000T](#) [DSC1001AI2-008.0000T](#) [DSC1001CI2-006.0000T](#) [DSC1001CI1-048.0000](#) [DSC1001AE2-080.0000T](#) [DSC1001CI1-025.0000T](#) [DSC1001AI2-048.0000T](#) [DSC1001AL5-133.3330T](#) [DSC1001DL2-020.0000T](#) [DSC1001AI1-020.0000T](#) [DSC1001AI2-012.0000T](#) [DSC1001CL5-048.0000T](#) [DSC1001BI1-004.0000T](#) [DSC1001CI2-022.5792T](#) [DSC1001DI1-033.3330](#) [DSC1001CE1-026.0000T](#) [DSC1001BI2-008.0000T](#) [DSC1001BI2-042.5000T](#) [DSC1001BI5-027.0000T](#) [DSC1001AI2-027.0000T](#) [DSC1001CI2-033.3333](#) [DSC1001CI2-019.4400T](#) [DSC1001DI2-125.0000](#) [DSC1001AI1-024.5760T](#) [DSC1001CL5-026.0000T](#) [DSC1001DI2-011.0592T](#) [DSC1001AI5-016.3840](#) [DSC1001AI5-016.3840T](#) [DSC1001CE1-050.0000](#) [DSC1001CI2-018.4320T](#) [DSC1001CI2-050.0000](#) [DSC1001CL1-025.0000T](#) [DSC1001DE1-019.2000](#) [DSC1001DE1-019.2000T](#) [DSC1001DE2-012.0000T](#) [DSC1001DI2-066.6600T](#) [DSC1001DL1-025.0000](#) [DSC1001CI2-096.0000](#) [DSC1001CL5-018.4320](#) [DSC1001CE2-012.2880](#) [DSC1001AI5-050.0000](#) [DSC1001CI5-080.0000T](#) [DSC1001AI5-050.0000T](#) [DSC1001CE1-004.0000T](#) [DSC1001DI2-019.2000](#) [DSC1001CL5-040.0000T](#) [DSC1001CL1-066.0000T](#) [DSC1001BL5-125.0000](#) [DSC1001CL5-033.3330](#) [DSC1001CE1-050.0000T](#) [DSC1001DE1-033.3333](#) [DSC1001CI2-027.0000](#) [DSC1001BL5-125.0000T](#) [DSC1001CL5-016.0000T](#) [DSC1001BL5-025.0000](#) [DSC1001CL5-018.4320T](#) [DSC1001CE2-100.0000T](#) [DSC1001CI2-002.0480T](#)

Looking for pricing, stock, or lifecycle information?

Click below to explore more details on WIN SOURCE:

 [View DSC1001CI1-033.3330 on WIN SOURCE](#)

 [Microchip Technology](#) Information

Optimize Your Supply Chain with WIN SOURCE Solutions

-  Global Sourcing Solution
-  Obsolete Management
-  Cost Control Management
-  Shortage Management
-  Alternative Solution
-  Excess Inventory Management