



**THE DATASHEET OF  
DSP56F802TA60E**



# 56F802

Data Sheet

*Preliminary Technical Data*

**56F800**  
**16-bit Digital Signal Controllers**

DSP56F802  
Rev. 9  
01/2007

[freescale.com](http://freescale.com)



# 56F802 General Description

- Up to 30 MIPS operation at 60MHz core frequency
- Up to 40 MIPS operation at 80MHz core frequency
- DSP and MCU functionality in a unified, C-efficient architecture
- MCU-friendly instruction set supports both DSP and controller functions: MAC, bit manipulation unit, 14 addressing modes
- Hardware DO and REP loops
- 6-channel PWM Module with fault input
- Two 12-bit ADCs (1 x 2 channel, 1 x 3 channel)
- Serial Communications Interface (SCI)
- Two General Purpose Quad Timers with 2 external outputs
- 8K × 16-bit words (16KB) Program Flash
- 1K × 16-bit words (2KB) Program RAM
- 2K × 16-bit words (4KB) Data Flash
- 1K × 16-bit words (2KB) Data RAM
- 2K × 16-bit words (4KB) Boot Flash
- JTAG/OnCE™ port for debugging
- On-chip relaxation oscillator
- 4 shared GPIO
- 32-pin LQFP Package

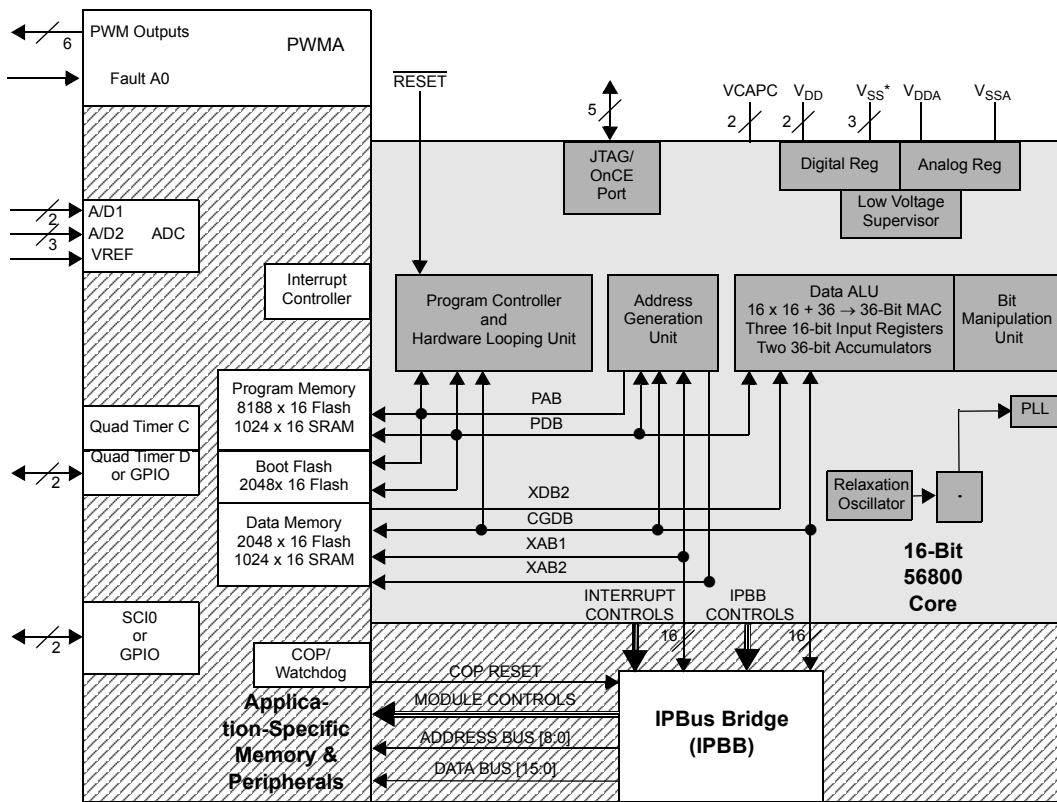

\*includes TCS pin which is reserved for factory use and is tied to VSS

## 56F802 Block Diagram

# Part 1 Overview

## 1.1 56F802 Features

### 1.1.1 Processing Core

- Efficient 16-bit 56800 family controller engine with dual Harvard architecture
- As many as 40 Million Instructions Per Second (MIPS) at 80 MHz core frequency
- Single-cycle  $16 \times 16$ -bit parallel Multiplier-Accumulator (MAC)
- Two 36-bit accumulators including extension bits
- 16-bit bidirectional barrel shifter
- Parallel instruction set with unique processor addressing modes
- Hardware DO and REP loops
- Three internal address buses and one external address bus
- Four internal data buses and one external data bus
- Instruction set supports both DSP and controller functions
- Controller style addressing modes and instructions for compact code
- Efficient C compiler and local variable support
- Software subroutine and interrupt stack with depth limited only by memory
- JTAG/OnCE debug programming interface

### 1.1.2 Memory

- Harvard architecture permits as many as three simultaneous accesses to program and data memory
- On-chip memory including a low-cost, high-volume Flash solution
  - $8K \times 16$  bit words of Program Flash
  - $1K \times 16$ -bit words of Program RAM
  - $2K \times 16$ -bit words of Data Flash
  - $1K \times 16$ -bit words of Data RAM
  - $2K \times 16$ -bit words of Boot Flash
- Programmable Boot Flash supports customized boot code and field upgrades of stored code through a variety of interfaces (JTAG)

### 1.1.3 Peripheral Circuits for 56F802

- Pulse Width Modulator (PWM) with six PWM outputs with deadtime insertion and fault protection; supports both center- and edge-aligned modes
- Two 12-bit, Analog-to-Digital Converters (ADCs), 1 x 2 channel and 1 x 3 channel, which support two simultaneous conversions; ADC and PWM modules can be synchronized
- Two General Purpose Quad Timers with two external pins (or two GPIO)
- Serial Communication Interface (SCI) with two pins (or two GPIO)
- Four multiplexed General Purpose I/O (GPIO) pins

- Computer-Operating Properly (COP) watchdog timer
- External interrupts via GPIO
- Trimmable on-chip relaxation oscillator
- External reset pin for hardware reset
- JTAG/On-Chip Emulation (OnCE™) for unobtrusive, processor speed-independent debugging
- Software-programmable, Phase Locked Loop-based frequency synthesizer for the controller core clock

### 1.1.4 Energy Information

- Fabricated in high-density CMOS with 5V-tolerant, TTL-compatible digital inputs
- Uses a single 3.3V power supply
- On-chip regulators for digital and analog circuitry to lower cost and reduce noise
- Wait and Stop modes available
- Integrated power supervisor

## 1.2 56F802 Description

The 56F802 is a member of the 56800 core-based family of processors. It combines, on a single chip, the processing power of a DSP and the functionality of a microcontroller with a flexible set of peripherals to create an extremely cost-effective solution. Because of its low cost, configuration flexibility, and compact program code, the 56F802 is well-suited for many applications. The 56F802 includes many peripherals that are especially useful for applications such as motion control, home appliances, encoders, tachometers, limit switches, power supply and control, engine management, and industrial control for power, lighting, automation and HVAC.

The 56800 core is based on a Harvard-style architecture consisting of three execution units operating in parallel, allowing as many as six operations per instruction cycle. The microprocessor-style programming model and optimized instruction set allow straightforward generation of efficient, compact code for both DSP and MCU applications. The instruction set is also highly efficient for C compilers to enable rapid development of optimized control applications.

The 56F802 supports program execution from either internal or external memories. Two data operands can be accessed from the on-chip Data RAM per instruction cycle. The 56F802 also provides and up to 4 General Purpose Input/Output (GPIO) lines, depending on peripheral configuration.

The 56F802 controller includes 8K words (16-bit) of Program Flash and 2K words of Data Flash (each programmable through the JTAG port) with 1K words of both Program and Data RAM. A total of 2K words of Boot Flash is incorporated for easy customer-inclusion of field-programmable software routines that can be used to program the main Program and Data Flash memory areas. Both Program and Data Flash memories can be independently bulk erased or erased in page sizes of 256 words. The Boot Flash memory can also be either bulk or page erased.

A key application-specific feature of the 56F802 is the inclusion of a Pulse Width Modulator (PWM) module. This module incorporates six complementary, individually programmable PWM signal outputs to enhance motor control functionality. Complementary operation permits programmable dead-time

insertion, and separate top and bottom output polarity control. The up-counter value is programmable to support a continuously variable PWM frequency. Both edge- and center-aligned synchronous pulse width control (0% to 100% modulation) are supported. The device is capable of controlling most motor types: ACIM (AC Induction Motors), both BDC and BLDC (Brush and Brushless DC motors), SRM and VRM (Switched and Variable Reluctance Motors), and stepper motors. The PWMs incorporate fault protection with sufficient output drive capability to directly drive standard opto-isolators. A “smoke-inhibit”, write-once protection feature for key parameters is also included. The PWM is double-buffered and includes interrupt control to permit integral reload rates to be programmable from 1 to 16. The PWM modules provide a reference output to synchronize the Analog-to-Digital Converters.

The 56F802 incorporates two 12-bit Analog-to-Digital Converters (ADCs) with a total of five channels. A full set of standard programmable peripherals is provided that include a Serial Communications Interface (SCI), and two Quad Timers. Any of these interfaces can be used as General-Purpose Input/Outputs (GPIO) if that function is not required. An on-chip relaxation oscillator eliminates the need for an external crystal.

### 1.3 State of the Art Development Environment

- Processor Expert™ (PE) provides a Rapid Application Design (RAD) tool that combines easy-to-use component-based software application creation with an expert knowledge system.
- The Code Warrior Integrated Development Environment is a sophisticated tool for code navigation, compiling, and debugging. A complete set of evaluation modules (EVMs) and development system cards will support concurrent engineering. Together, PE, Code Warrior and EVMs create a complete, scalable tools solution for easy, fast, and efficient development.

### 1.4 Product Documentation

The four documents listed in [Table 1-1](#) are required for a complete description and proper design with the 56F802. Documentation is available from local Freescale distributors, Freescale semiconductor sales offices, Freescale Literature Distribution Centers, or online at [www.freescale.com](http://www.freescale.com).

**Table 1-1 56F802 Chip Documentation**

Topic	Description	Order Number
56800E Family Manual	Detailed description of the 56800 family architecture, and 16-bit core processor and the instruction set	56800EFM
DSP56F801/803/805/807 User's Manual	Detailed description of memory, peripherals, and interfaces of the 56F801, 56F802, 56F803, 56F805, and 56F807	DSP56F801-7UM
56F802 Technical Data Sheet	Electrical and timing specifications, pin descriptions, and package descriptions (this document)	DSP56F802
56F802 Errata	Details any chip issues that might be present	56F802E

## 1.5 Data Sheet Conventions

This data sheet uses the following conventions:

$\overline{\text{OVERBAR}}$  This is used to indicate a signal that is active when pulled low. For example, the  $\overline{\text{RESET}}$  pin is active when low.

“asserted” A high true (active high) signal is high or a low true (active low) signal is low.

“deasserted” A high true (active high) signal is low or a low true (active low) signal is high.

Examples:	Signal/Symbol	Logic State	Signal State	Voltage <sup>1</sup>
	$\overline{\text{PIN}}$	True	Asserted	$V_{\text{IL}}/V_{\text{OL}}$
	$\overline{\text{PIN}}$	False	Deasserted	$V_{\text{IH}}/V_{\text{OH}}$
	PIN	True	Asserted	$V_{\text{IH}}/V_{\text{OH}}$
	PIN	False	Deasserted	$V_{\text{IL}}/V_{\text{OL}}$

1. Values for  $V_{\text{IL}}$ ,  $V_{\text{OL}}$ ,  $V_{\text{IH}}$ , and  $V_{\text{OH}}$  are defined by individual product specifications

## Part 2 Signal/Connection Descriptions

### 2.1 Introduction

The input and output signals of the 56F802 are organized into functional groups, as shown in [Table 2-1](#) and as illustrated in [Figure 2-1](#). In [Table 2-2](#) through [Table 2-10](#), each table row describes the signal or signals present on a pin.

**Table 2-1 Functional Group Pin Allocations**

Functional Group	Number of Pins	Detailed Description
Power ( $V_{DD}$ or $V_{DDA}$ )	3	<a href="#">Table 2-2</a>
Ground ( $V_{SS}$ , $V_{SSA}$ , TCS)	4	<a href="#">Table 2-3</a>
Supply Capacitors	2	<a href="#">Table 2-4</a>
Program Control	1	<a href="#">Table 2-5</a>
Pulse Width Modulator (PWM) Port and Fault Input	7	<a href="#">Table 2-6</a>
Serial Communications Interface (SCI) Port <sup>1</sup>	2	<a href="#">Table 2-7</a>
Analog-to-Digital Converter (ADC) Port (including $V_{REF}$ )	6	<a href="#">Table 2-8</a>
Quad Timer Module Port	2	<a href="#">Table 2-9</a>
JTAG/On-Chip Emulation (OnCE)	5	<a href="#">Table 2-10</a>

1. Alternately, GPIO pins

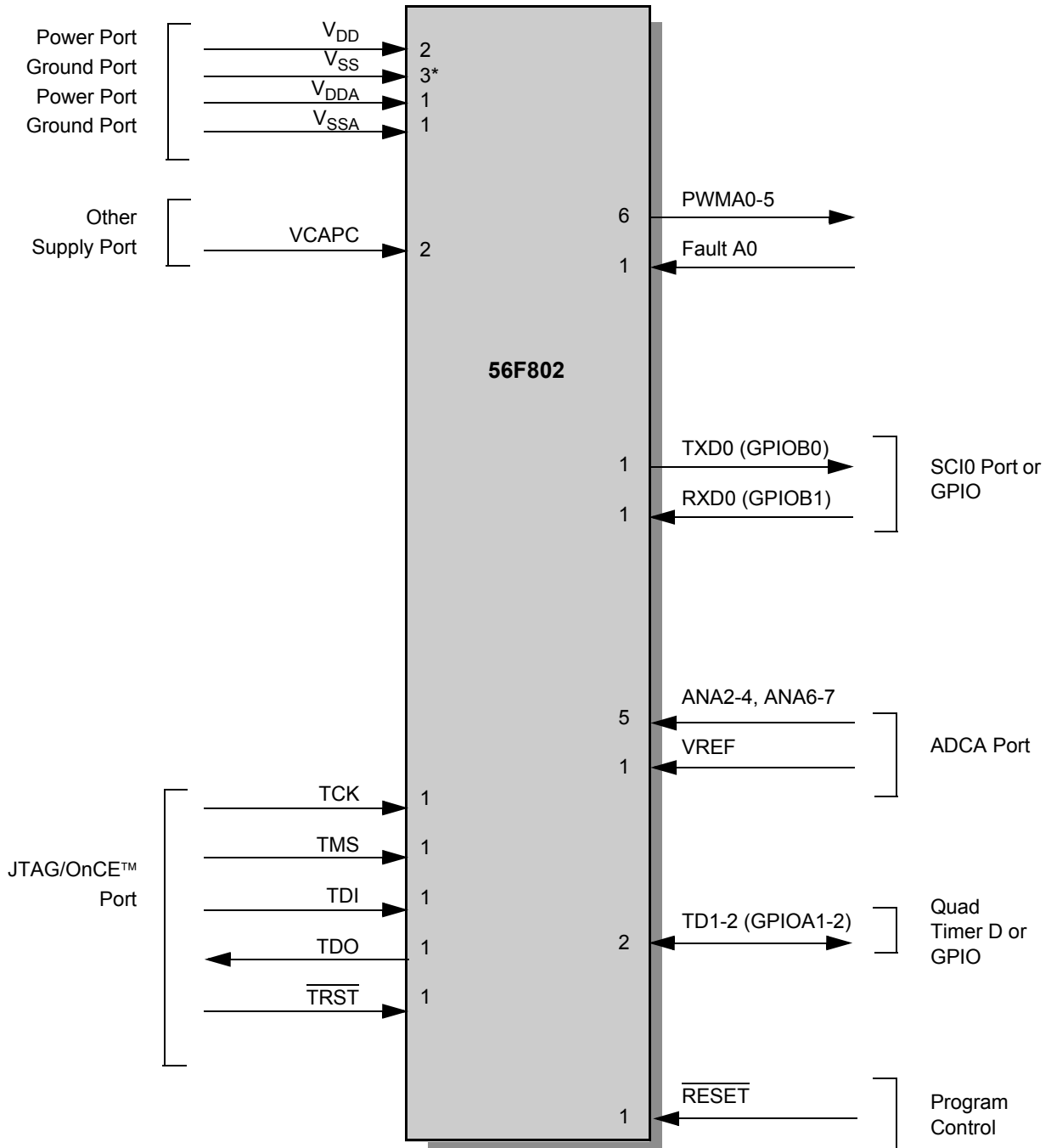

\*includes TCS pin which is reserved for factory use and is tied to VSS

**Figure 2-1 56F802 Signals Identified by Functional Group<sup>1</sup>**

1. Alternate pin functionality is shown in parenthesis.

## 2.2 Power and Ground Signals

**Table 2-2 Power Inputs**

No. of Pins	Signal Name	Signal Description
2	V <sub>DD</sub>	<b>Power</b> —These pins provide power to the internal structures of the chip, and should all be attached to V <sub>DD</sub> .
1	V <sub>DDA</sub>	<b>Analog Power</b> —This pin is a dedicated power pin for the analog portion of the chip and should be connected to a low noise 3.3V supply.

**Table 2-3 Grounds**

No. of Pins	Signal Name	Signal Description
2	V <sub>SS</sub>	<b>GND</b> —These pins provide grounding for the internal structures of the chip, and should all be attached to V <sub>SS</sub> .
1	V <sub>SSA</sub>	<b>Analog Ground</b> —This pin supplies an analog ground.
1	TCS	<b>TCS</b> —This Schmitt pin is reserved for factory use and must be tied to V <sub>SS</sub> for normal use. In block diagrams, this pin is considered an additional V <sub>SS</sub> .

**Table 2-4 Supply Capacitors and VPP**

No. of Pins	Signal Name	Signal Type	State During Reset	Signal Description
2	VCAPC	Supply	Supply	<b>VCAPC</b> —Connect each pin to a 2.2 μF or greater bypass capacitor in order to bypass the core logic voltage regulator (required for proper chip operation). For more information, refer to <a href="#">Section 5.2</a>

## 2.3 Interrupt and Program Control Signals

**Table 2-5 Program Control Signals**

No. of Pins	Signal Name	Signal Type	State During Reset	Signal Description
1	<b>RESET</b>	Input (Schmitt)	Input	<p><b>Reset</b>—This input is a direct hardware reset on the processor. When <b>RESET</b> is asserted low, the controller is initialized and placed in the Reset state. A Schmitt trigger input is used for noise immunity. When the <b>RESET</b> pin is deasserted, the initial chip operating mode is latched from the <b>EXTBOOT</b> pin. The internal reset signal will be deasserted synchronous with the internal clocks, after a fixed number of internal clocks.</p> <p>To ensure complete hardware reset, <math>\overline{\text{RESET}}</math> and <math>\overline{\text{TRST}}</math> should be asserted together. The only exception occurs in a debugging environment when a hardware device reset is required and it is necessary not to reset the OnCE/JTAG module. In this case, assert <b>RESET</b>, but do not assert <b>TRST</b>.</p>

## 2.4 Pulse Width Modulator (PWM) Signals

**Table 2-6 Pulse Width Modulator (PWMA) Signals**

No. of Pins	Signal Name	Signal Type	State During Reset	Signal Description
6	<b>PWMA0-5</b>	Output	Tri-stated	<b>PWMA0-5</b> — These are six PWMA output pins.
1	<b>FAULTA0</b>	Input (Schmitt)	Input	<b>FAULTA0</b> —This fault input is used for disabling selected PWMA outputs in cases where fault conditions originate off-chip.

## 2.5 Serial Communications Interface (SCI) Signals

**Table 2-7 Serial Communications Interface (SCI0) Signals**

No. of Pins	Signal Name	Signal Type	State During Reset	Signal Description
1	<b>TXD0</b>	Output	Input	<b>Transmit Data (TXD0)</b> —SCI0 transmit data output
	<b>GPIOB0</b>	Input/Output	Input	<p><b>Port B GPIO</b>—This pin is a General Purpose I/O (GPIO) pin that can be individually programmed as an input or output pin.</p> <p>After reset, the default state is SCI output.</p>

**Table 2-7 Serial Communications Interface (SCI0) Signals (Continued)**

No. of Pins	Signal Name	Signal Type	State During Reset	Signal Description
1	<b>RXD0</b>	Input	Input	<b>Receive Data (RXD0)</b> —SCI0 receive data input
	<b>GPIOB1</b>	Input/Output	Input	<b>Port B GPIO</b> —This pin is a General Purpose I/O (GPIO) pin that can be individually programmed as an input or output pin.  After reset, the default state is SCI input.

## 2.6 Analog-to-Digital Converter (ADC) Signals

**Table 2-8 Analog to Digital Converter Signals**

No. of Pins	Signal Name	Signal Type	State During Reset	Signal Description
3	<b>ANA2-4</b>	Input	Input	<b>ANA2-4</b> —Analog inputs to ADC, channel 1
2	<b>ANA6-7</b>	Input	Input	<b>ANA6-7</b> —Analog inputs to ADC, channel 2
1	<b>VREF</b>	Input	Input	<b>VREF</b> —Analog reference voltage. Must be set to $V_{DDA} - 0.3V$ for optimal performance.

## 2.7 Quad Timer Module Signals

**Table 2-9 Quad Timer Module Signals**

No. of Pins	Signal Name	Signal Type	State During Reset	Signal Description
2	<b>TD1-2</b>	Input/Output	Input	<b>TD1-2</b> —Timer D Channel 1-2
	<b>GPIOA1-2</b>	Input/Output	Input	<b>Port A GPIO</b> —These pins are General Purpose I/O (GPIO) pins that can be individually programmed as input or output pins.  After reset, the default state is the quad timer input.

## 2.8 JTAG/OnCE

**Table 2-10 JTAG/On-Chip Emulation (OnCE) Signals**

No. of Pins	Signal Name	Signal Type	State During Reset	Signal Description
1	<b>TCK</b>	Input (Schmitt)	Input, pulled low internally	<b>Test Clock Input</b> —This input pin provides a gated clock to synchronize the test logic and shift serial data to the JTAG/OnCE port. The pin is connected internally to a pull-down resistor.
1	<b>TMS</b>	Input (Schmitt)	Input, pulled high internally	<b>Test Mode Select Input</b> —This input pin is used to sequence the JTAG TAP controller's state machine. It is sampled on the rising edge of TCK and has an on-chip pull-up resistor.  <b>Note:</b> Always tie the TMS pin to $V_{DD}$ through a 2.2K resistor.
1	<b>TDI</b>	Input (Schmitt)	Input, pulled high internally	<b>Test Data Input</b> —This input pin provides a serial input data stream to the JTAG/OnCE port. It is sampled on the rising edge of TCK and has an on-chip pull-up resistor.
1	<b>TDO</b>	Output	Tri-stated	<b>Test Data Output</b> —This tri-statable output pin provides a serial output data stream from the JTAG/OnCE port. It is driven in the Shift-IR and Shift-DR controller states, and changes on the falling edge of TCK.
1	<b><math>\overline{\text{TRST}}</math></b>	Input (Schmitt)	Input, pulled high internally	<b>Test Reset</b> —As an input, a low signal on this pin provides a reset signal to the JTAG TAP controller. To ensure complete hardware reset, $\overline{\text{TRST}}$ should be asserted at power-up and whenever RESET is asserted. The only exception occurs in a debugging environment, since the OnCE/JTAG module is under the control of the debugger. In this case it is not necessary to assert $\overline{\text{TRST}}$ when asserting RESET. Outside of a debugging environment RESET should be permanently asserted by grounding the signal, thus disabling the OnCE/JTAG module on the device.  <b>Note:</b> For normal operation, connect $\overline{\text{TRST}}$ directly to $V_{SS}$ . If the design is to be used in a debugging environment, $\overline{\text{TRST}}$ may be tied to $V_{SS}$ through a 1K resistor.

## Part 3 Specifications

### 3.1 General Characteristics

The 56F802 is fabricated in high-density CMOS with 5-volt tolerant TTL-compatible digital inputs. The term “5-volt tolerant” refers to the capability of an I/O pin, built on a 3.3V compatible process technology, to withstand a voltage up to 5.5V without damaging the device. Many systems have a mixture of devices designed for 3.3V and 5V power supplies. In such systems, a bus may carry both 3.3V and 5V-compatible I/O voltage levels (a standard 3.3V I/O is designed to receive a maximum voltage of  $3.3V \pm 10\%$  during normal operation without causing damage). This 5V-tolerant capability therefore offers the power savings of 3.3V I/O levels while being able to receive 5V levels without being damaged.

Absolute maximum ratings given in [Table 3-1](#) are stress ratings only, and functional operation at the maximum is not guaranteed. Stress beyond these ratings may affect device reliability or cause permanent damage to the device.

The 56F802 DC and AC electrical specifications are preliminary and are from design simulations. These specifications may not be fully tested or guaranteed at this early stage of the product life cycle. Finalized specifications will be published after complete characterization and device qualifications have been completed.

### CAUTION

**This device contains protective circuitry to guard against damage due to high static voltage or electrical fields. However, normal precautions are advised to avoid application of any voltages higher than maximum rated voltages to this high-impedance circuit. Reliability of operation is enhanced if unused inputs are tied to an appropriate voltage level.**

**Table 3-1 Absolute Maximum Ratings**

Characteristic	Symbol	Min	Max	Unit
Supply voltage	$V_{DD}$	$V_{SS} - 0.3$	$V_{SS} + 4.0$	V
All other input voltages, excluding Analog inputs	$V_{IN}$	$V_{SS} - 0.3$	$V_{SS} + 5.5V$	V
Voltage difference $V_{DD}$ to $V_{DDA}$	$\Delta V_{DD}$	-0.3	0.3	V
Voltage difference $V_{SS}$ to $V_{SSA}$	$\Delta V_{SS}$	-0.3	0.3	V
Analog Inputs ANAx, $V_{REF}$	$V_{IN}$	$V_{SS} - 0.3$	$V_{DDA} + 0.3V$	V
Current drain per pin excluding $V_{DD}$ , $V_{SS}$ , & PWM outputs	I	—	10	mA

**Table 3-2 Recommended Operating Conditions**

Characteristic	Symbol	Min	Typ	Max	Unit
Supply voltage, digital	$V_{DD}$	3.0	3.3	3.6	V
Supply Voltage, analog	$V_{DDA}$	3.0	3.3	3.6	V
Voltage difference $V_{DD}$ to $V_{DDA}$	$\Delta V_{DD}$	-0.1	-	0.1	V
Voltage difference $V_{SS}$ to $V_{SSA}$	$\Delta V_{SS}$	-0.1	-	0.1	V

**Table 3-2 Recommended Operating Conditions**

Characteristic	Symbol	Min	Typ	Max	Unit
ADC reference voltage <sup>1</sup>	VREF	2.7	–	V <sub>DDA</sub>	V
Ambient operating temperature	T <sub>A</sub>	–40	–	85	°C

1. VREF must be 0.3V below V<sub>DDA</sub>.

**Table 3-3 Thermal Characteristics<sup>6</sup>**

Characteristic	Comments	Symbol	Value	Unit	Notes
			32-pin LQFP		
Junction to ambient Natural convection		R <sub>θJA</sub>	50.2	°C/W	2
Junction to ambient (@1m/sec)		R <sub>θJMA</sub>	47.1	°C/W	2
Junction to ambient Natural convection	Four layer board (2s2p)	R <sub>θJMA</sub> (2s2p)	38.7	°C/W	1,2
Junction to ambient (@1m/sec)	Four layer board (2s2p)	R <sub>θJMA</sub>	37.4	°C/W	1,2
Junction to case		R <sub>θJC</sub>	17.8	°C/W	3
Junction to center of case		Ψ <sub>JT</sub>	3.07	°C/W	4
I/O pin power dissipation		P <sub>I/O</sub>	User Determined	W	
Power dissipation		P <sub>D</sub>	P <sub>D</sub> = (I <sub>DD</sub> × V <sub>DD</sub> + P <sub>I/O</sub> )	W	
Junction to center of case		P <sub>D</sub> MAX	(T <sub>J</sub> - T <sub>A</sub> ) / R <sub>θJA</sub>	W	7

**Notes:**

- Theta-JA determined on 2s2p test boards is frequently lower than would be observed in an application. Determined on 2s2p thermal test board.
- Junction to ambient thermal resistance, Theta-JA (R<sub>θJA</sub>) was simulated to be equivalent to the JEDEC specification JESD51-2 in a horizontal configuration in natural convection. Theta-JA was also simulated on a thermal test board with two internal planes (2s2p where s is the number of signal layers and p is the number of planes) per JESD51-6 and JESD51-7. The correct name for Theta-JA for forced convection or with the non-single layer boards is Theta-JMA.
- Junction to case thermal resistance, Theta-JC (R<sub>θJC</sub>), was simulated to be equivalent to the measured values using the cold plate technique with the cold plate temperature used as the "case" temperature. The basic cold plate measurement technique is described by MIL-STD 883D, Method 1012.1. This is the correct thermal metric to use to calculate thermal performance when the package is being used with a heat sink.
- Thermal Characterization Parameter, Psi-JT (Ψ<sub>JT</sub>), is the "resistance" from junction to reference point thermocouple on top center of case as defined in JESD51-2. Ψ<sub>JT</sub> is a useful value to use to estimate junction temperature in steady state customer environments.

5. Junction temperature is a function of on-chip power dissipation, package thermal resistance, mounting site (board) temperature, ambient temperature, air flow, power dissipation of other components on the board, and board thermal resistance.
6. See Section 5.1 from more details on thermal design considerations.
7. TJ = Junction Temperature  
TA = Ambient Temperature

## 3.2 DC Electrical Characteristics

**Table 3-4 DC Electrical Characteristics**

Operating Conditions:  $V_{SS} = V_{SSA} = 0\text{ V}$ ,  $V_{DD} = V_{DDA} = 3.0\text{--}3.6\text{ V}$ ,  $T_A = -40^\circ\text{ to }+85^\circ\text{C}$ ,  $C_L \leq 50\text{pF}$

Characteristic	Symbol	Min	Typ	Max	Unit
Input high voltage (XTAL/EXTAL)	$V_{IHC}$	2.25	—	2.75	V
Input low voltage (XTAL/EXTAL)	$V_{ILC}$	0	—	0.5	V
Input high voltage (Schmitt trigger inputs) <sup>1</sup>	$V_{IHS}$	2.2	—	5.5	V
Input low voltage (Schmitt trigger inputs) <sup>1</sup>	$V_{ILS}$	-0.3	—	0.8	V
Input high voltage (all other digital inputs)	$V_{IH}$	2.0	—	5.5	V
Input low voltage (all other digital inputs)	$V_{IL}$	-0.3	—	0.8	V
Input current high (pullup/pulldown resistors disabled, $V_{IN}=V_{DD}$ )	$I_{IH}$	-1	—	1	$\mu\text{A}$
Input current low (pullup/pulldown resistors disabled, $V_{IN}=V_{SS}$ )	$I_{IL}$	-1	—	1	$\mu\text{A}$
Input current high (with pullup resistor, $V_{IN}=V_{DD}$ )	$I_{IHPU}$	-1	—	1	$\mu\text{A}$
Input current low (with pullup resistor, $V_{IN}=V_{SS}$ )	$I_{ILPU}$	-210	—	-50	$\mu\text{A}$
Input current high (with pulldown resistor, $V_{IN}=V_{DD}$ )	$I_{IHPD}$	20	—	180	$\mu\text{A}$
Input current low (with pulldown resistor, $V_{IN}=V_{SS}$ )	$I_{ILPD}$	-1	—	1	$\mu\text{A}$
Nominal pullup or pulldown resistor value	$R_{PU}, R_{PD}$		30		$\text{K}\Omega$
Output tri-state current low	$I_{OZL}$	-10	—	10	$\mu\text{A}$
Output tri-state current high	$I_{OZH}$	-10	—	10	$\mu\text{A}$
Input current high (analog inputs, $V_{IN}=V_{DDA}$ ) <sup>2</sup>	$I_{IHA}$	-15	—	15	$\mu\text{A}$
Input current low (analog inputs, $V_{IN}=V_{SSA}$ ) <sup>2</sup>	$I_{ILA}$	-15	—	15	$\mu\text{A}$
Output High Voltage (at IOH)	$V_{OH}$	$V_{DD} - 0.7$	—	—	V

**Table 3-4 DC Electrical Characteristics (Continued)**  
 Operating Conditions:  $V_{SS} = V_{SSA} = 0\text{ V}$ ,  $V_{DD} = V_{DDA} = 3.0\text{--}3.6\text{ V}$ ,  $T_A = -40^\circ\text{ to }+85^\circ\text{C}$ ,  $C_L \leq 50\text{pF}$

Characteristic	Symbol	Min	Typ	Max	Unit
Output Low Voltage (at IOL)	$V_{OL}$	—	—	0.4	V
Output source current	$I_{OH}$	4	—	—	mA
Output sink current	$I_{OL}$	4	—	—	mA
PWM pin output source current <sup>3</sup>	$I_{OHP}$	10	—	—	mA
PWM pin output sink current <sup>4</sup>	$I_{OLP}$	16	—	—	mA
Input capacitance	$C_{IN}$	—	8	—	pF
Output capacitance	$C_{OUT}$	—	12	—	pF
$V_{DD}$ supply current	$I_{DDT}^5$				
Run <sup>6</sup> (80MHz Operation)		—	120	130	mA
Run <sup>6</sup> (60MHz Operation)		—	102	111	mA
Wait <sup>7</sup>		—	96	102	mA
Stop		—	62	70	mA
Low Voltage Interrupt, external power supply <sup>8</sup>	$V_{EIO}$	2.4	2.7	3.0	V
Low Voltage Interrupt, internal power supply <sup>9</sup>	$V_{EIC}$	2.0	2.2	2.4	V
Power on Reset <sup>10</sup>	$V_{POR}$	—	1.7	2.0	V

- Schmitt Trigger inputs are: FAULTA0, TCS, TCK, TMS, TDI, RESET, and TRST
- Analog inputs are: ANA[0:7], XTAL and EXTAL. Specification assumes ADC is not sampling.
- PWM pin output source current measured with 50% duty cycle.
- PWM pin output sink current measured with 50% duty cycle.
- $I_{DDT} = I_{DD} + I_{DDA}$  (Total supply current for  $V_{DD} + V_{DDA}$ )
- Run (operating)  $I_{DD}$  measured using 8MHz clock source. All inputs 0.2V from rail; outputs unloaded. All ports configured as inputs; measured with all modules enabled.
- Wait  $I_{DD}$  measured using external square wave clock source ( $f_{osc} = 8\text{MHz}$ ) into XTAL; all inputs 0.2V from rail; no DC loads; less than 50pF on all outputs.  $C_L = 20\text{pF}$  on EXTAL; all ports configured as inputs; EXTAL capacitance linearly affects wait  $I_{DD}$ ; measured with PLL enabled.
- This low voltage interrupt monitors the  $V_{DDA}$  external power supply.  $V_{DDA}$  is generally connected to the same potential as  $V_{DD}$  via separate traces. If  $V_{DDA}$  drops below  $V_{EIO}$ , an interrupt is generated. Functionality of the device is guaranteed under transient conditions when  $V_{DDA} \geq V_{EIO}$  (between the minimum specified  $V_{DD}$  and the point when the  $V_{EIO}$  interrupt is generated).
- This low voltage interrupt monitors the internally regulated core power supply. If the output from the internal voltage is regulator drops below  $V_{EIC}$ , an interrupt is generated. Since the core logic supply is internally regulated, this interrupt will not be generated unless the external power supply drops below the minimum specified value (3.0V).

10. Power-on reset occurs whenever the internally regulated 2.5V digital supply drops below 1.5V typical. While power is ramping up, this signal remains active for as long as the internal 2.5V is below 1.5V typical no matter how long the ramp up rate is. The internally regulated voltage is typically 100 mV less than  $V_{DD}$  during ramp up until 2.5V is reached, at which time it self regulates.

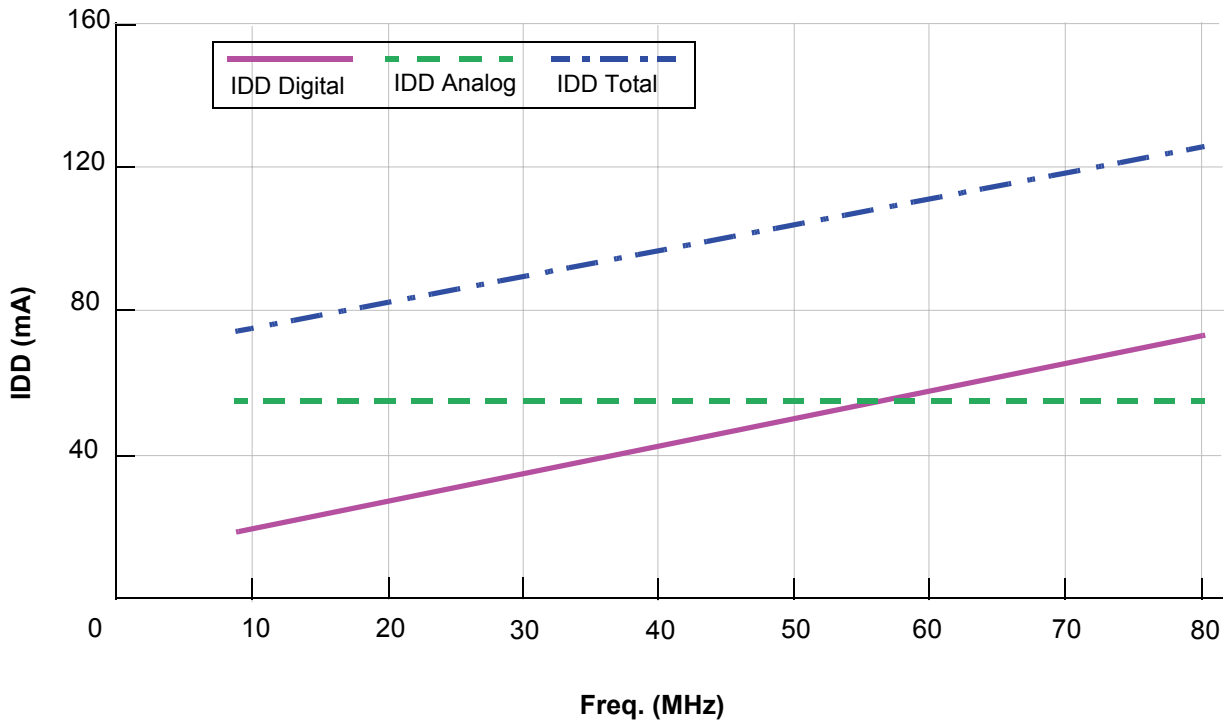
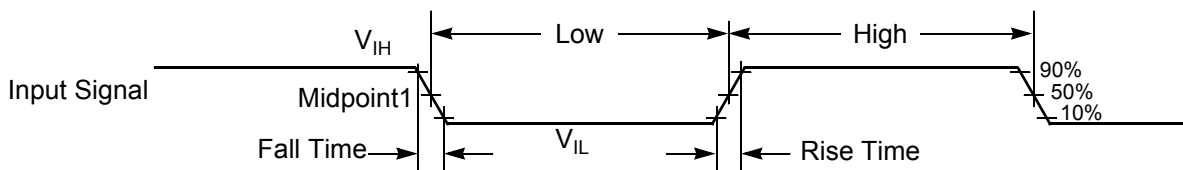

Figure 3-1 Maximum Run IDD vs. Frequency (see Note 6. in Table 3-4)

### 3.3 AC Electrical Characteristics

Timing waveforms in Section 3.3 are tested using the  $V_{IL}$  and  $V_{IH}$  levels specified in the DC Characteristics table. In Figure 3-2 the levels of  $V_{IH}$  and  $V_{IL}$  for an input signal are shown.



Note: The midpoint is  $V_{IL} + (V_{IH} - V_{IL})/2$ .

Figure 3-2 Input Signal Measurement References

Figure 3-3 shows the definitions of the following signal states:

- Active state, when a bus or signal is driven, and enters a low impedance state
- Tri-stated, when a bus or signal is placed in a high impedance state

- Data Valid state, when a signal level has reached  $V_{OL}$  or  $V_{OH}$
- Data Invalid state, when a signal level is in transition between  $V_{OL}$  and  $V_{OH}$

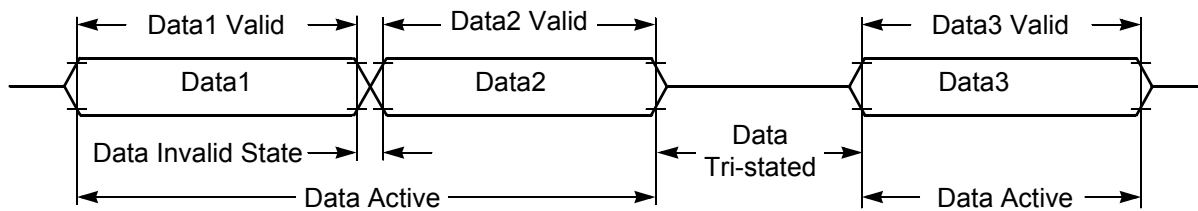
**Figure 3-3 Signal States**

## 3.4 Flash Memory Characteristics

**Table 3-5 Flash Memory Truth Table**

Mode	XE <sup>1</sup>	YE <sup>2</sup>	SE <sup>3</sup>	OE <sup>4</sup>	PROG <sup>5</sup>	ERASE <sup>6</sup>	MAS1 <sup>7</sup>	NVSTR <sup>8</sup>
Standby	L	L	L	L	L	L	L	L
Read	H	H	H	H	L	L	L	L
Word Program	H	H	L	L	H	L	L	H
Page Erase	H	L	L	L	L	H	L	H
Mass Erase	H	L	L	L	L	H	H	H

1. X address enable, all rows are disabled when XE = 0
2. Y address enable, YMUX is disabled when YE = 0
3. Sense amplifier enable
4. Output enable, tri-state Flash data out bus when OE = 0
5. Defines program cycle
6. Defines erase cycle
7. Defines mass erase cycle, erase whole block
8. Defines non-volatile store cycle

**Table 3-6 IFREN Truth Table**

Mode	IFREN = 1	IFREN = 0
Read	Read information block	Read main memory block
Word program	Program information block	Program main memory block
Page erase	Erase information block	Erase main memory block
Mass erase	Erase both blocks	Erase main memory block

**Table 3-7 Flash Timing Parameters**

Operating Conditions:  $V_{SS} = V_{SSA} = 0\text{ V}$ ,  $V_{DD} = V_{DDA} = 3.0\text{--}3.6\text{ V}$ ,  $T_A = -40^\circ\text{ to }+85^\circ\text{C}$ ,  $C_L \leq 50\text{ pF}$

Characteristic	Symbol	Min	Typ	Max	Unit	Figure
Program time	$T_{\text{prog}}^*$	20	–	–	us	Figure 3-4
Erase time	$T_{\text{erase}}^*$	20	–	–	ms	Figure 3-5
Mass erase time	$T_{\text{me}}^*$	100	–	–	ms	Figure 3-6
Endurance <sup>1</sup>	$E_{\text{CYC}}$	10,000	20,000	–	cycles	
Data Retention <sup>1</sup>	$D_{\text{RET}}$	10	30	–	years	

The following parameters should only be used in the Manual Word Programming Mode

PROG/ERASE to NVSTR set up time	$T_{\text{nvst}}^*$	–	5	–	us	Figure 3-4, Figure 3-5, Figure 3-6
NVSTR hold time	$T_{\text{nvh}}^*$	–	5	–	us	Figure 3-4, Figure 3-5
NVSTR hold time (mass erase)	$T_{\text{nvh1}}^*$	–	100	–	us	Figure 3-6
NVSTR to program set up time	$T_{\text{pgs}}^*$	–	10	–	us	Figure 3-4
Recovery time	$T_{\text{rcv}}^*$	–	1	–	us	Figure 3-4, Figure 3-5, Figure 3-6
Cumulative program HV period <sup>2</sup>	$T_{\text{hv}}$	–	3	–	ms	Figure 3-4
Program hold time <sup>3</sup>	$T_{\text{pgh}}$	–	–	–		Figure 3-4
Address/data set up time <sup>3</sup>	$T_{\text{ads}}$	–	–	–		Figure 3-4
Address/data hold time <sup>3</sup>	$T_{\text{adh}}$	–	–	–		Figure 3-4

1. One Cycle is equal to an erase program and read.

2.  $T_{\text{hv}}$  is the cumulative high voltage programming time to the same row before next erase. The same address cannot be programmed twice before next erase.

3. Parameters are guaranteed by design in smart programming mode and must be one cycle or greater.

\*The Flash interface unit provides registers for the control of these parameters.

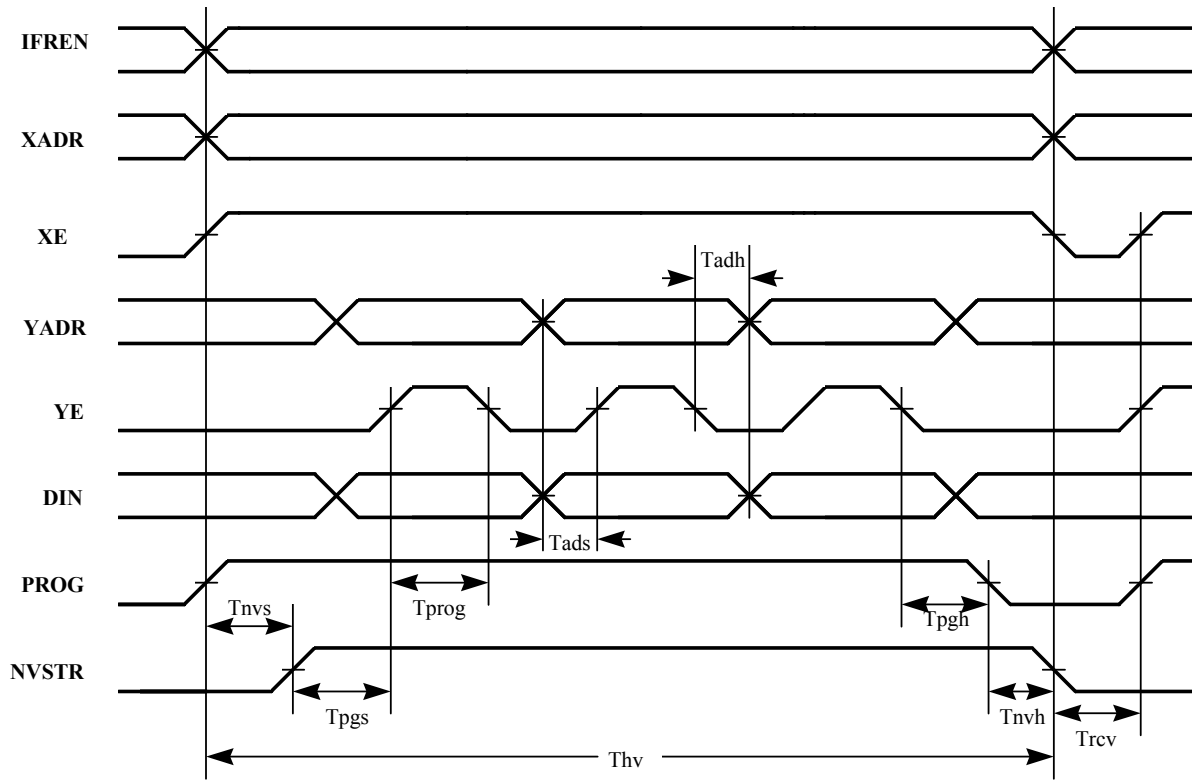
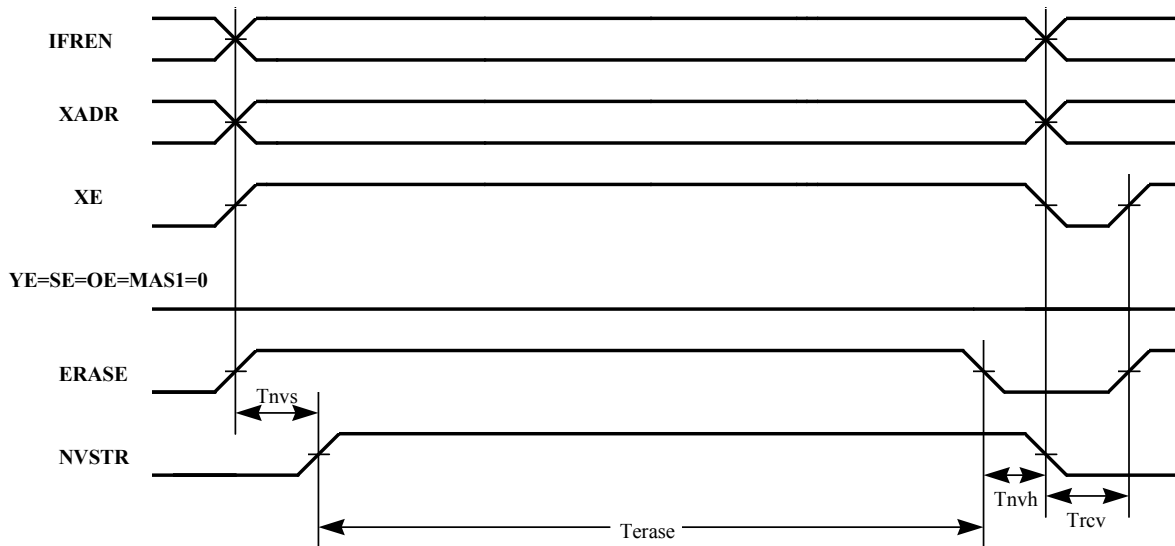
**Figure 3-4 Flash Program Cycle**

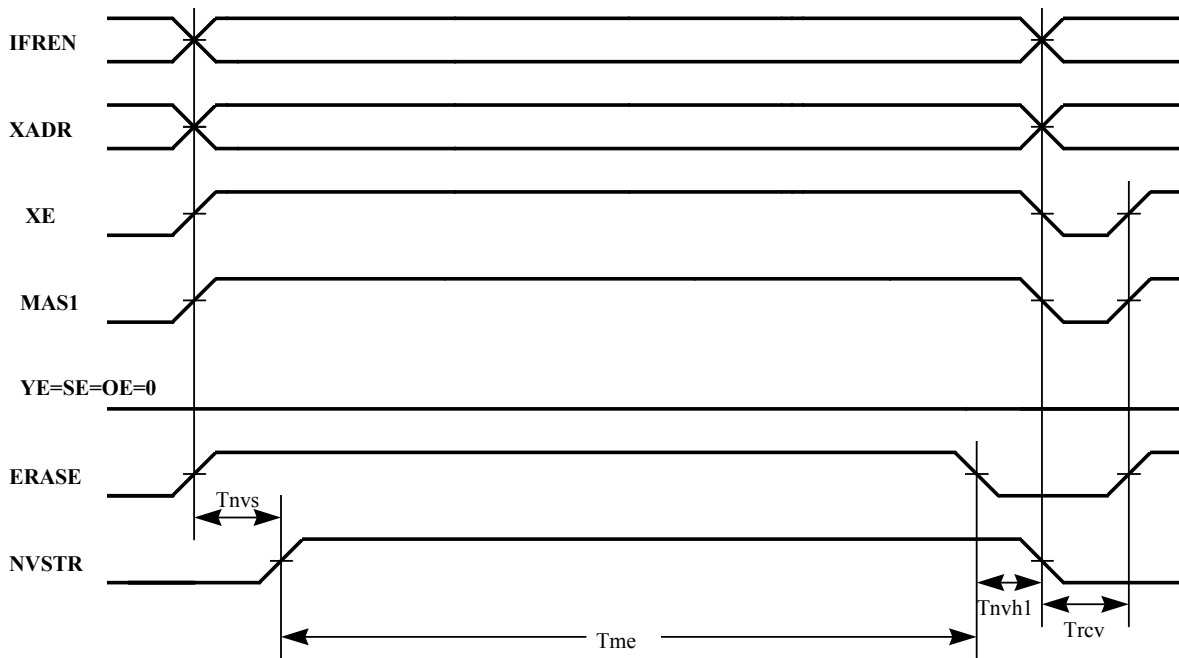
**Figure 3-5 Flash Erase Cycle**



**Figure 3-6 Flash Mass Erase Cycle**

## 3.5 Clock Operation

The 56F802 device clock is derived from an on-chip relaxation oscillator. The internal PLL generates a master reference frequency that determines the speed at which chip operations occur.

The PRECS bit in the PLLCR (phase-locked loop control register) word (bit 2) must be set to 0 for internal oscillator use.

### 3.5.1 Use of On-Chip Relaxation Oscillator

The 56F802 internal relaxation oscillator provides the chip clock without the need for an external crystal or ceramic resonator. The frequency output of this internal oscillator can be corrected by adjusting the 8-bit IOSCTL (internal oscillator control) register. Each bit added or deleted changes the output frequency of the oscillator allowing incremental adjustment until the desired frequency is achieved. Figures 9 and 10 show the typical characteristics of the 56F802 relaxation oscillator with respect to temperature and trim value.

During factory production test, an oscillator calibration procedure is executed which determines an optimum trim value for a given device (8MHz at 25°C). This optimum trim value is then stored at address \$103F in the Data Flash Information Block and recalled during a trim routine in the boot sequence (executed after power-up and RESET). This trim routine automatically sets the oscillator frequency by programming the IOSCTL register with the optimum trim value.

Due to the inherent frequency tolerances required for SCI communication, changing the factory-trimmed oscillator frequency is not recommended. If modification of the Boot Flash contents are required, code must be included which retrieves the optimum trim value (from address \$103F in the Data Flash Information Block) and writes it to the IOSCTL register. Note that the IFREN bit in the Data Flash control register must be set in order to read the Data Flash Information Block.

**Table 3-8 Relaxation Oscillator Characteristics**

Operating Conditions:  $V_{SS} = V_{SSA} = 0\text{ V}$ ,  $V_{DD} = V_{DDA} = 3.0\text{--}3.6\text{ V}$ ,  $T_A = -40^\circ\text{ to }+85^\circ\text{C}$

Characteristic	Symbol	Min	Typ	Max	Unit
Frequency Accuracy <sup>1</sup>	$\Delta f$	—	$\pm 2$	$\pm 5$	%
Frequency Drift over Temp	$\Delta f/\Delta t$	—	$\pm 0.1$	—	%/ $^\circ\text{C}$
Frequency Drift over Supply	$\Delta f/\Delta V$	—	0.1	—	%/V

1. Over full temperature range.

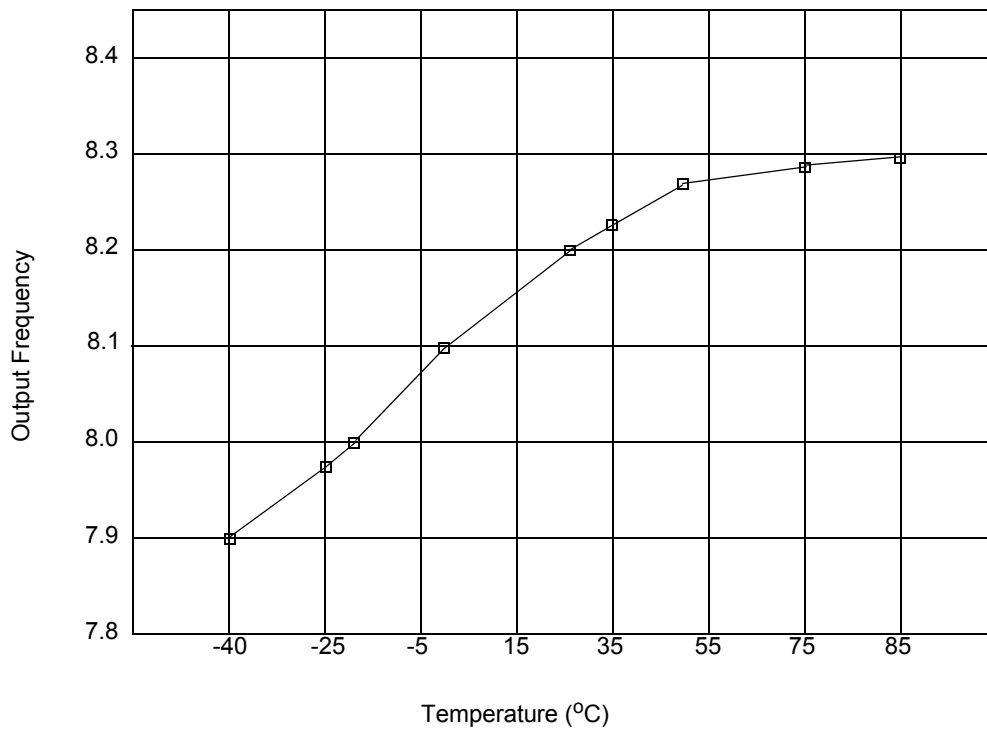

**Figure 3-7 Typical Relaxation Oscillator Frequency vs. Temperature (Trimmed to 8MHz @ 25 $^\circ\text{C}$ )**

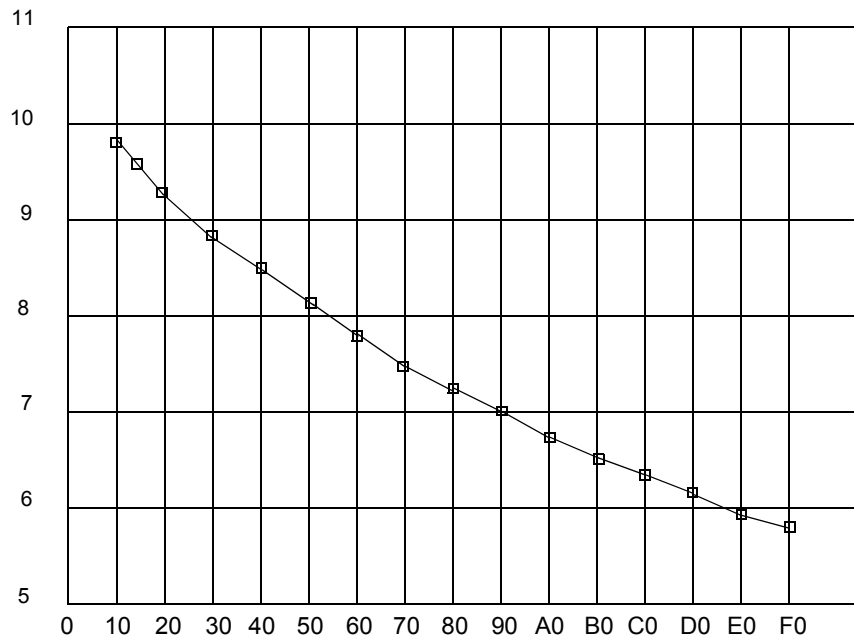

Figure 3-8 Typical Relaxation Oscillator Frequency vs. Trim Value @ 25°C

### 3.5.2 Phase Locked Loop Timing

Table 3-9 PLL Timing

Characteristic	Symbol	Min	Typ	Max	Unit
Frequency for the PLL <sup>1</sup>	$f_{osc}$	4	8	10	MHz
PLL output frequency <sup>2</sup>	$f_{out}/2$	40	—	80 <sup>3</sup>	MHz
PLL stabilization time <sup>4</sup> 0° to +85°C	$t_{plls}$	—	10	—	ms
PLL stabilization time <sup>4</sup> -40° to 0°C	$t_{plls}$	—	100	200	ms

1. An externally supplied reference clock should be as free as possible from any phase jitter for the PLL to work correctly. The PLL is optimized for 8MHz input crystal.
2. ZCLK may not exceed 80MHz. For additional information on ZCLK and  $f_{out}/2$ , please refer to the OCCS chapter in the User Manual.  $ZCLK = f_{op}$
3. Will not exceed 60MHz for the DSP56F802TA60 device.
4. This is the minimum time required after the PLL setup is changed to ensure reliable operation.

### 3.6 Reset, Stop, Wait, Mode Select, and Interrupt Timing

**Table 3-10 Reset, Stop, Wait, Mode Select, and Interrupt Timing<sup>1, 3</sup>**  
 Operating Conditions:  $V_{SS} = V_{SSA} = 0\text{ V}$ ,  $V_{DD} = V_{DDA} = 3.0\text{--}3.6\text{ V}$ ,  $T_A = -40^\circ\text{ to }+85^\circ\text{C}$ ,  $C_L \leq 50\text{pF}$

Characteristic	Symbol	Min	Max	Unit
$\overline{\text{RESET}}$ Assertion to Address, Data and Control Signals High Impedance	$t_{\text{RAZ}}$	—	21	ns
Minimum $\overline{\text{RESET}}$ Assertion Duration <sup>2</sup> OMR Bit 6 = 0 OMR Bit 6 = 1	$t_{\text{RA}}$	275,000T 128T	— —	ns ns
$\overline{\text{RESET}}$ De-assertion to First External Address Output	$t_{\text{RDA}}$	33T	34T	ns
Edge-sensitive Interrupt Request Width	$t_{\text{IRW}}$	1.5T	—	ns

1. In the formulas, T = clock cycle. For an operating frequency of 80MHz, T = 12.5ns.
2. Circuit stabilization delay is required during reset when using an external clock or crystal oscillator in two cases:
  - After power-on reset
  - When recovering from Stop state
3. Parameters listed are guaranteed by design.

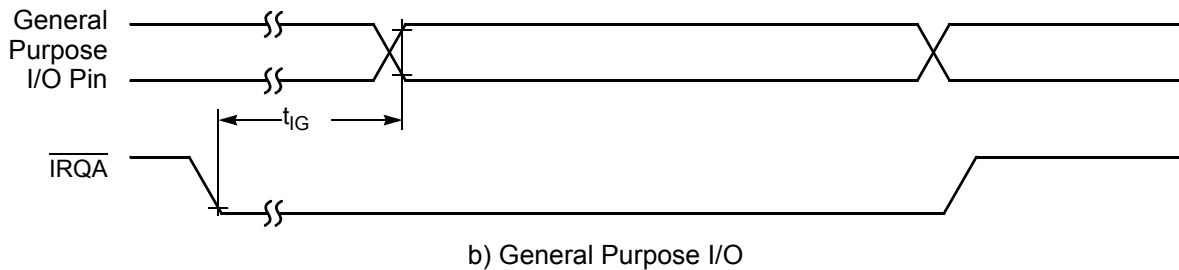

**Figure 3-9 External Level-Sensitive Interrupt Timing**

### 3.7 Quad Timer Timing

**Table 3-11 Timer Timing<sup>1, 2</sup>**

Operating Conditions:  $V_{SS} = V_{SSA} = 0\text{ V}$ ,  $V_{DD} = V_{DDA} = 3.0\text{--}3.6\text{ V}$ ,  $T_A = -40^\circ\text{ to }+85^\circ\text{C}$ ,  $C_L \leq 50\text{pF}$

Characteristic	Symbol	Min	Max	Unit
Timer input period	$P_{IN}$	$4T+6$	—	ns
Timer input high/low period	$P_{INHL}$	$2T+3$	—	ns
Timer output period	$P_{OUT}$	$2T$	—	ns
Timer output high/low period	$P_{OUTHL}$	$1T$	—	ns

1. In the formulas listed,  $T$  = clock cycle. For 80MHz operation,  $T = 12.5\text{ ns}$ .
2. Parameters listed are guaranteed by design.

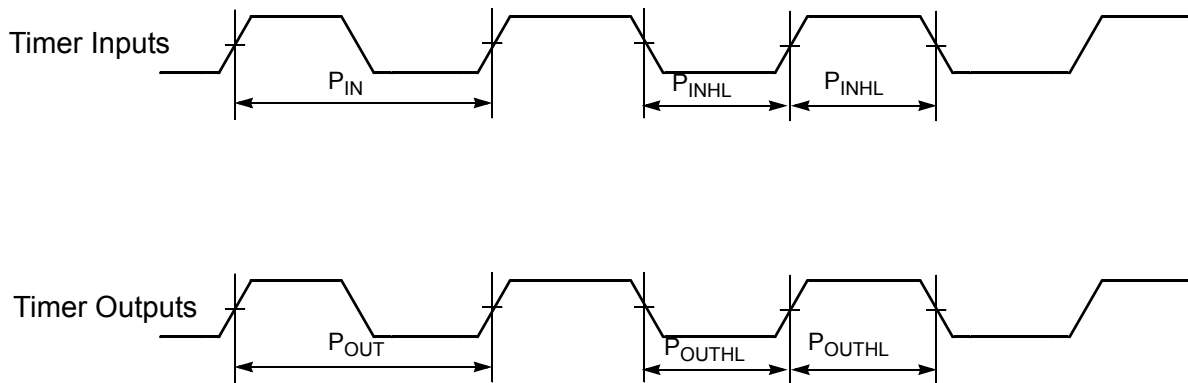

**Figure 3-10 Timer Timing**

## 3.8 Serial Communication Interface (SCI) Timing

**Table 3-12 SCI Timing<sup>4</sup>**

Operating Conditions:  $V_{SS} = V_{SSA} = 0\text{ V}$ ,  $V_{DD} = V_{DDA} = 3.0\text{--}3.6\text{ V}$ ,  $T_A = -40^\circ\text{ to }+85^\circ\text{C}$ ,  $C_L \leq 50\text{pF}$

Characteristic	Symbol	Min	Max	Unit
Baud Rate <sup>1</sup>	BR	—	$(f_{\text{MAX}} * 2.5) / (80)$	Mbps
RXD <sup>2</sup> Pulse Width	RXD <sub>PW</sub>	0.965/BR	1.04/BR	ns
TXD <sup>3</sup> Pulse Width	TXD <sub>PW</sub>	0.965/BR	1.04/BR	ns

- $f_{\text{MAX}}$  is the frequency of operation of the system clock in MHz.
- The RXD pin in SCI0 is named RXD0 and the RXD pin in SCI1 is named RXD1.
- The TXD pin in SCI0 is named TXD0 and the TXD pin in SCI1 is named TXD1.
- Parameters listed are guaranteed by design.

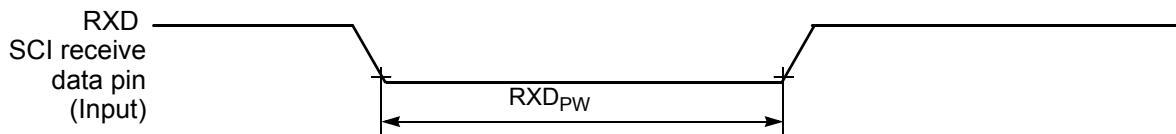

**Figure 3-11 RXD Pulse Width**

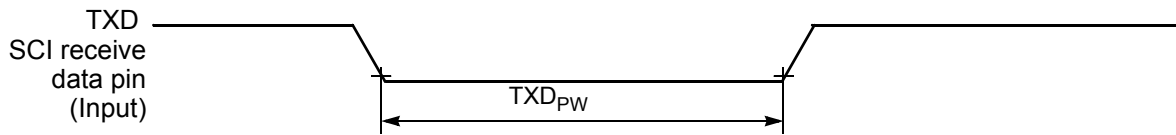

**Figure 3-12 TXD Pulse Width**

### 3.9 Analog-to-Digital Converter (ADC) Characteristics

**Table 3-13 ADC Characteristics**

Characteristic	Symbol	Min	Typ	Max	Unit
ADC input voltages	$V_{ADCIN}$	0 <sup>1</sup>	—	$V_{REF}$ <sup>2</sup>	V
Resolution	$R_{ES}$	12	—	12	Bits
Integral Non-Linearity <sup>3</sup>	INL	—	+/- 4	+/- 5	LSB <sup>4</sup>
Differential Non-Linearity	DNL	—	+/- 0.9	+/- 1	LSB <sup>3</sup>
Monotonicity	GUARANTEED				
ADC internal clock <sup>5</sup>	$f_{ADIC}$	0.5	—	5	MHz
Conversion range	$R_{AD}$	$V_{SSA}$	—	$V_{DDA}$	V
Power-up time	$t_{ADPU}$	—	2.5	—	msec
Conversion time	$t_{ADC}$	—	6	—	$t_{AIC}$ cycles <sup>6</sup>
Sample time	$t_{ADS}$	—	1	—	$t_{AIC}$ cycles <sup>6</sup>
Input capacitance	$C_{ADI}$	—	5	—	pF <sup>6</sup>
Gain Error (transfer gain) <sup>5</sup>	$E_{GAIN}$	1.00	1.10	1.15	—
Offset Voltage <sup>5</sup>	$V_{OFFSET}$	+10	+230	+325	mV
Total Harmonic Distortion <sup>5</sup>	THD	55	60	—	dB
Signal-to-Noise plus Distortion <sup>5</sup>	SINAD	54	56	—	—
Effective Number of Bits <sup>5</sup>	ENOB	8.5	9.5	—	bit
Spurious Free Dynamic Range <sup>5</sup>	SFDR	60	65	—	dB
Spurious Free Dynamic Range	SFDR	65	70	—	dB
ADC Quiescent Current (both ADCs)	$I_{ADC}$	—	50	—	mA
$V_{REF}$ Quiescent Current (both ADCs)	$I_{VREF}$	—	12	16.5	mA

1. For optimum ADC performance, keep the minimum  $V_{ADCIN}$  value  $\geq 250$ mV. Inputs less than 250mV volts may convert to a digital output code of 0 or cause erroneous conversions.

2.  $V_{REF}$  must be equal to or less than  $V_{DDA} - 0.3$ V and must be greater than 2.7V.

3. Measured in 10-90% range.

4. LSB = Least Significant Bit.

5. Guaranteed by characterization.

6.  $t_{AIC} = 1/f_{ADIC}$

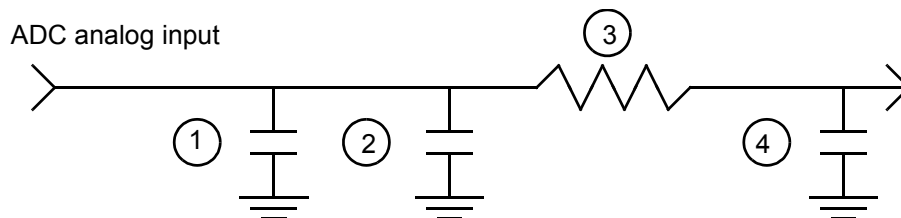

1. Parasitic capacitance due to package, pin to pin, and pin to package base coupling. (1.8pf)
2. Parasitic capacitance due to the chip bond pad, ESD protection devices and signal routing. (2.04pf)
3. Equivalent resistance for the ESD isolation resistor and the channel select mux. (500 ohms)
4. Sampling capacitor at the sample and hold circuit. Capacitor 4 is normally disconnected from the input and is only connected to it at sampling time. (1pf)

**Figure 3-13 Equivalent Analog Input Circuit**

## 3.10 JTAG Timing

**Table 3-14 JTAG Timing<sup>1, 3</sup>**

Operating Conditions:  $V_{SS} = V_{SSA} = 0\text{ V}$ ,  $V_{DD} = V_{DDA} = 3.0\text{--}3.6\text{ V}$ ,  $T_A = -40^\circ\text{ to }+85^\circ\text{C}$ ,  $C_L \leq 50\text{ pF}$

Characteristic	Symbol	Min	Max	Unit
TCK frequency of operation <sup>2</sup>	$f_{OP}$	DC	10	MHz
TCK cycle time	$t_{CY}$	100	—	ns
TCK clock pulse width	$t_{PW}$	50	—	ns
TMS, TDI data setup time	$t_{DS}$	0.4	—	ns
TMS, TDI data hold time	$t_{DH}$	1.2	—	ns
TCK low to TDO data valid	$t_{DV}$	—	26.6	ns
TCK low to TDO tri-state	$t_{TS}$	—	23.5	ns
$\overline{\text{TRST}}$ assertion time	$t_{TRST}$	50	—	ns

1. Timing is both wait state and frequency dependent. For the values listed, T = clock cycle. For 80MHz operation, T = 12.5ns.
2. TCK frequency of operation must be less than 1/8 the processor rate.
3. Parameters listed are guaranteed by design.

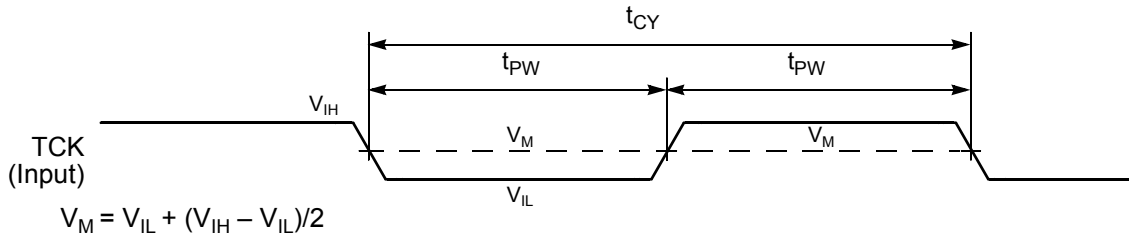

**Figure 3-14 Test Clock Input Timing Diagram**

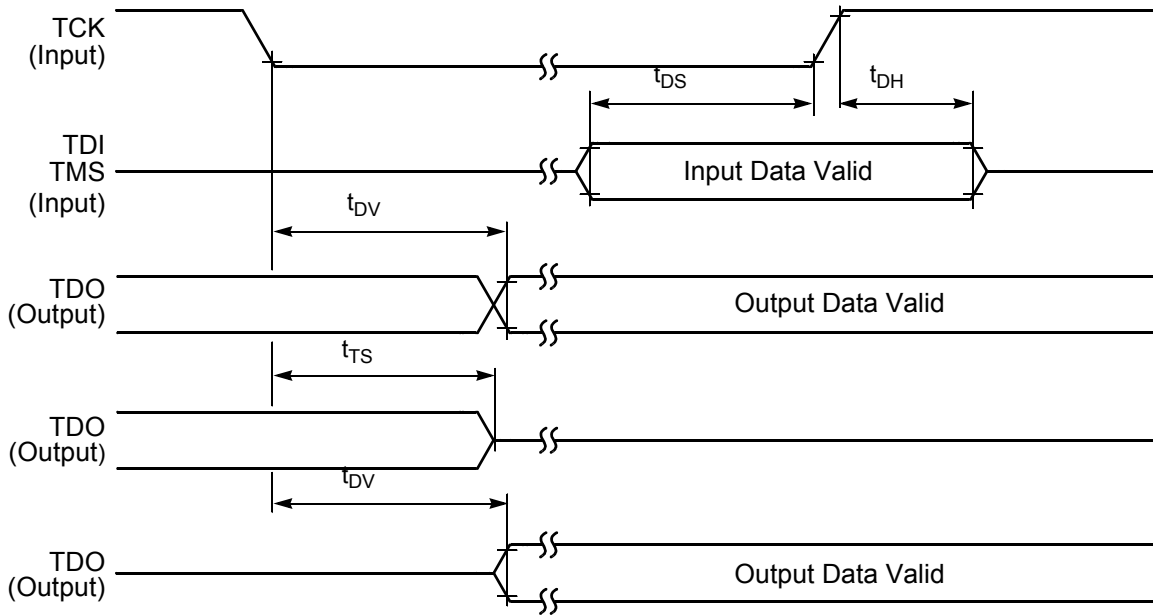

**Figure 3-15 Test Access Port Timing Diagram**

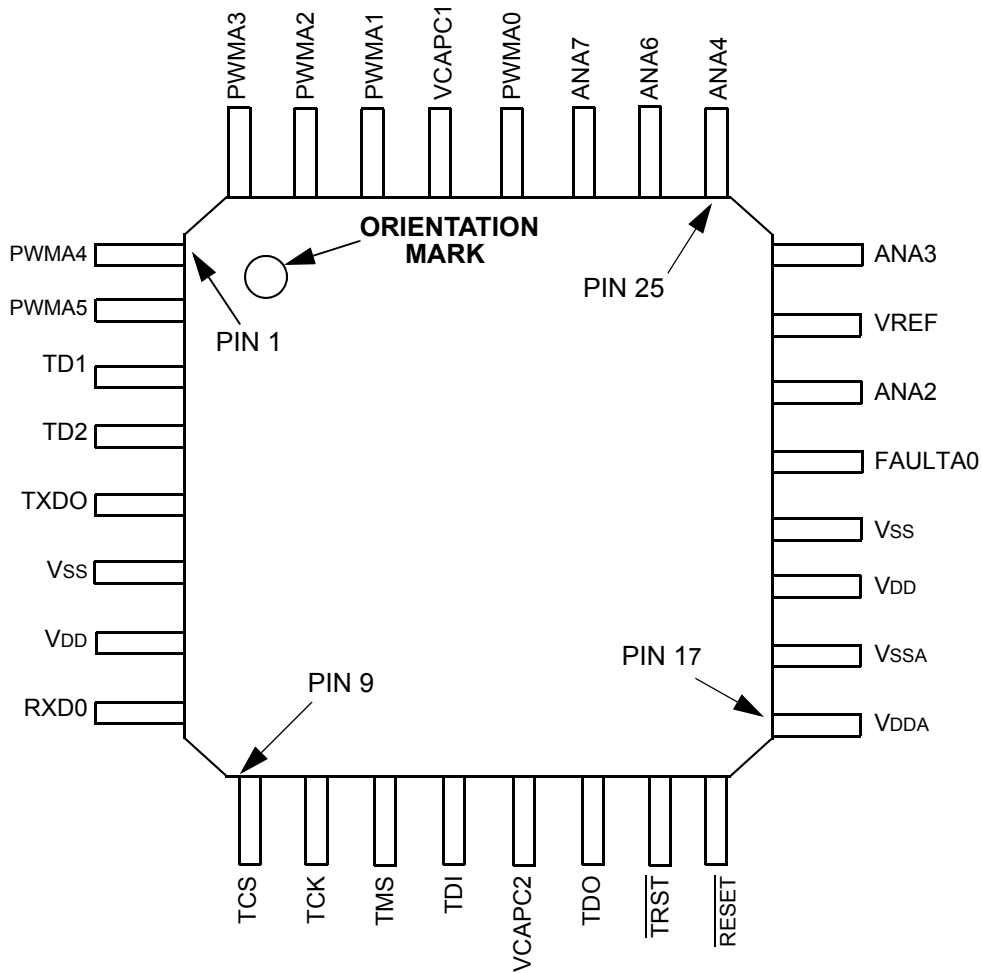

**Figure 3-16 TRST Timing Diagram**

## Part 4 Packaging

### 4.1 Package and Pin-Out Information 56F802

This section contains package and pin-out information for the 32-pin LQFP configuration of the 56F802.



**Figure 4-1 Top View, 56F802 32-pin LQFP Package**

**Table 4-1 56F802 Pin Identification by Pin Number**

Pin No.	Signal Name	Pin No.	Signal Name	Pin No.	Signal Name	Pin No.	Signal Name
1	PWMA4	9	TCS	17	V <sub>DDA</sub>	25	ANA4
2	PWMA5	10	TCK	18	V <sub>SSA</sub>	26	ANA6
3	TD1	11	TMS	19	V <sub>DD</sub>	27	ANA7
4	TD2	12	TDI	20	V <sub>SS</sub>	28	PWMA0
5	TXDO	13	VCAPC2	21	FAULTA0	29	VCAPC1
6	V <sub>SS</sub>	14	TDO	22	ANA2	30	PWMA1
7	V <sub>DD</sub>	15	$\overline{\text{TRST}}$	23	VREF	31	PWMA2
8	RXD0	16	$\overline{\text{RESET}}$	24	ANA3	32	PWMA3

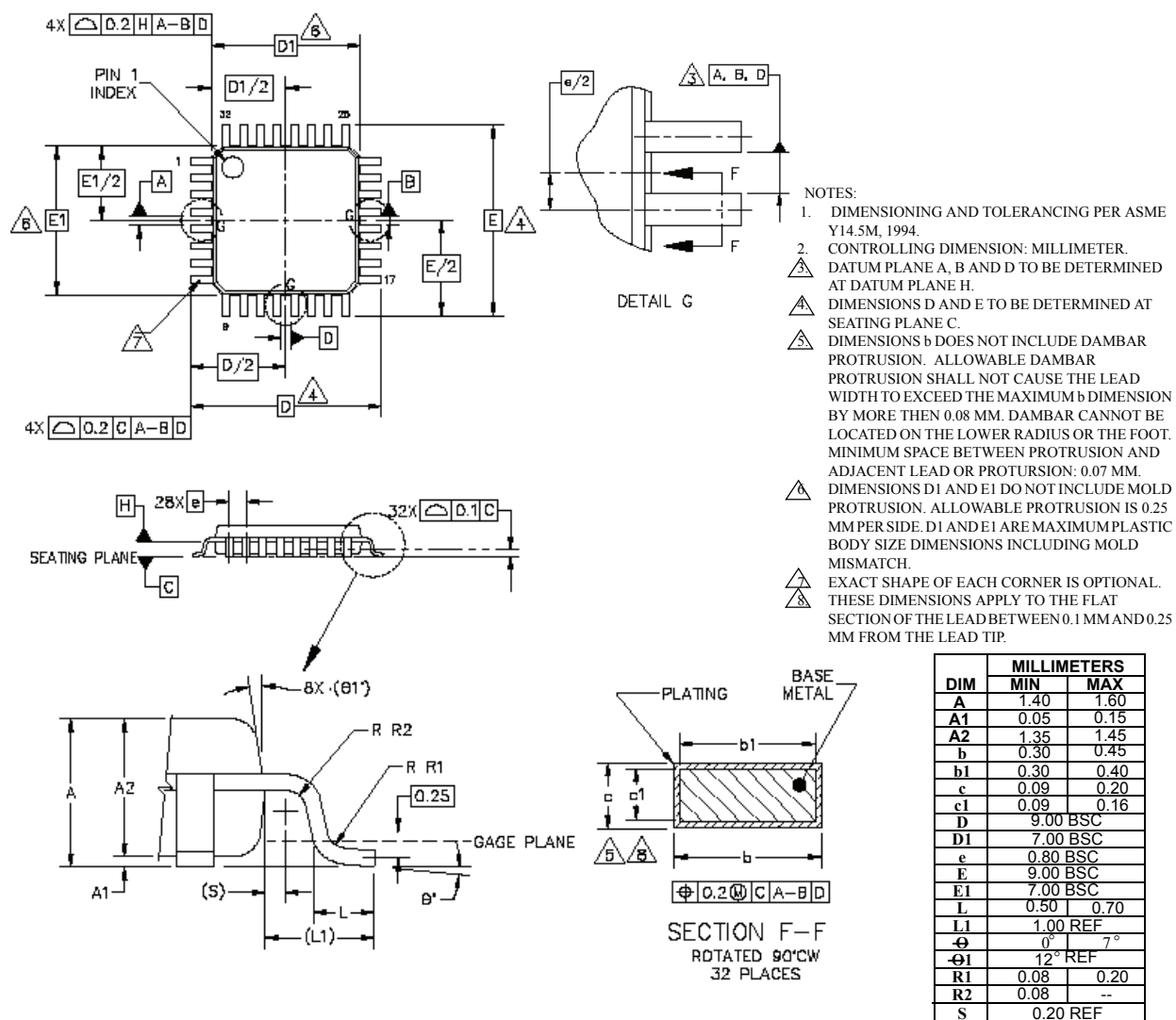

Figure 4-2 32-pin LQFP Mechanical Information (Case 873A)

Please see [www.freescale.com](http://www.freescale.com) for the most current case outline.

## Part 5 Design Considerations

### 5.1 Thermal Design Considerations

An estimation of the chip junction temperature,  $T_J$ , in °C can be obtained from the equation:

$$\text{Equation 1: } T_J = T_A + (P_D \times R_{\theta JA})$$

Where:

$T_A$  = ambient temperature °C

$R_{\theta JA}$  = package junction-to-ambient thermal resistance °C/W

$P_D$  = power dissipation in package

Historically, thermal resistance has been expressed as the sum of a junction-to-case thermal resistance and a case-to-ambient thermal resistance:

$$\text{Equation 2: } R_{\theta JA} = R_{\theta JC} + R_{\theta CA}$$

Where:

$R_{\theta JA}$  = package junction-to-ambient thermal resistance °C/W

$R_{\theta JC}$  = package junction-to-case thermal resistance °C/W

$R_{\theta CA}$  = package case-to-ambient thermal resistance °C/W

$R_{\theta JC}$  is device-related and cannot be influenced by the user. The user controls the thermal environment to change the case-to-ambient thermal resistance,  $R_{\theta CA}$ . For example, the user can change the air flow around the device, add a heat sink, change the mounting arrangement on the Printed Circuit Board (PCB), or otherwise change the thermal dissipation capability of the area surrounding the device on the PCB. This model is most useful for ceramic packages with heat sinks; some 90% of the heat flow is dissipated through the case to the heat sink and out to the ambient environment. For ceramic packages, in situations where the heat flow is split between a path to the case and an alternate path through the PCB, analysis of the device thermal performance may need the additional modeling capability of a system level thermal simulation tool.

The thermal performance of plastic packages is more dependent on the temperature of the PCB to which the package is mounted. Again, if the estimations obtained from  $R_{\theta JA}$  do not satisfactorily answer whether the thermal performance is adequate, a system level model may be appropriate.

#### Definitions:

A complicating factor is the existence of three common definitions for determining the junction-to-case thermal resistance in plastic packages:

- Measure the thermal resistance from the junction to the outside surface of the package (case) closest to the chip mounting area when that surface has a proper heat sink. This is done to minimize temperature variation across the surface.

- Measure the thermal resistance from the junction to where the leads are attached to the case. This definition is approximately equal to a junction to board thermal resistance.
- Use the value obtained by the equation  $(T_J - T_T)/P_D$  where  $T_T$  is the temperature of the package case determined by a thermocouple.

The thermal characterization parameter is measured per JESD51-2 specification using a 40-gauge type T thermocouple epoxied to the top center of the package case. The thermocouple should be positioned so that the thermocouple junction rests on the package. A small amount of epoxy is placed over the thermocouple junction and over about 1mm of wire extending from the junction. The thermocouple wire is placed flat against the package case to avoid measurement errors caused by cooling effects of the thermocouple wire.

When heat sink is used, the junction temperature is determined from a thermocouple inserted at the interface between the case of the package and the interface material. A clearance slot or hole is normally required in the heat sink. Minimizing the size of the clearance is important to minimize the change in thermal performance caused by removing part of the thermal interface to the heat sink. Because of the experimental difficulties with this technique, many engineers measure the heat sink temperature and then back-calculate the case temperature using a separate measurement of the thermal resistance of the interface. From this case temperature, the junction temperature is determined from the junction-to-case thermal resistance.

## 5.2 Electrical Design Considerations

### CAUTION

**This device contains protective circuitry to guard against damage due to high static voltage or electrical fields. However, normal precautions are advised to avoid application of any voltages higher than maximum rated voltages to this high-impedance circuit. Reliability of operation is enhanced if unused inputs are tied to an appropriate voltage level.**

Use the following list of considerations to assure correct operation:

- Provide a low-impedance path from the board power supply to each  $V_{DD}$  pin on the controller, and from the board ground to each  $V_{SS}$  (GND) pin.
- The minimum bypass requirement is to place 0.1  $\mu\text{F}$  capacitors positioned as close as possible to the package supply pins. The recommended bypass configuration is to place one bypass capacitor on each of the  $V_{DD}/V_{SS}$  pairs, including  $V_{DDA}/V_{SSA}$ . Ceramic and tantalum capacitors tend to provide better performance tolerances.

- Ensure that capacitor leads and associated printed circuit traces that connect to the chip  $V_{DD}$  and  $V_{SS}$  (GND) pins are less than 0.5 inch per capacitor lead.
- Bypass the  $V_{DD}$  and  $V_{SS}$  layers of the PCB with approximately 100  $\mu\text{F}$ , preferably with ceramic or tantalum capacitors which tend to provide better performance tolerances.
- Because the controller's output signals have fast rise and fall times, PCB trace lengths should be minimal.
- Consider all device loads as well as parasitic capacitance due to PCB traces when calculating capacitance. This is especially critical in systems with higher capacitive loads that could create higher transient currents in the  $V_{DD}$  and GND circuits.
- Take special care to minimize noise levels on the  $V_{REF}$ ,  $V_{DDA}$  and  $V_{SSA}$  pins.
- Designs that utilize the  $\overline{\text{TRST}}$  pin for JTAG port or OnCE module functionality (such as development or debugging systems) should allow a means to assert  $\overline{\text{TRST}}$  whenever RESET is asserted, as well as a means to assert  $\overline{\text{TRST}}$  independently of RESET.  $\overline{\text{TRST}}$  must be asserted at power up for proper operation. Designs that do not require debugging functionality, such as consumer products,  $\overline{\text{TRST}}$  should be tied low.
- Because the Flash memory is programmed through the JTAG/OnCE port, designers should provide an interface to this port to allow in-circuit Flash programming.

## Part 6 Ordering Information

**Table 6-1** lists the pertinent information needed to place an order. Consult a Freescale Semiconductor sales office or authorized distributor to determine availability and to order parts.

**Table 6-1 56F802 Ordering Information**

Part	Supply Voltage	Package Type	Pin Count	Ambient Frequency (MHz)	Order Number
56F802	3.0–3.6 V	Low Profile Plastic Quad Flat Pack (LQFP)	32	80	DSP56F802TA80
56F802	3.0–3.6 V	Low Profile Plastic Quad Flat Pack (LQFP)	32	60	DSP56F802TA60
56F802	3.0–3.6 V	Low Profile Plastic Quad Flat Pack (LQFP)	32	80	DSP56F802TA80E*
56F802	3.0–3.6 V	Low Profile Plastic Quad Flat Pack (LQFP)	32	60	DSP56F802TA60E*

\*This package is RoHS compliant.







## **How to Reach Us:**

### **Home Page:**

www.freescale.com

### **E-mail:**

support@freescale.com

### **USA/Europe or Locations Not Listed:**

Freescale Semiconductor  
Technical Information Center, CH370  
1300 N. Alma School Road  
Chandler, Arizona 85224  
+1-800-521-6274 or +1-480-768-2130  
support@freescale.com

### **Europe, Middle East, and Africa:**

Freescale Halbleiter Deutschland GmbH  
Technical Information Center  
Schatzbogen 7  
81829 Muenchen, Germany  
+44 1296 380 456 (English)  
+46 8 52200080 (English)  
+49 89 92103 559 (German)  
+33 1 69 35 48 48 (French)  
support@freescale.com

### **Japan:**

Freescale Semiconductor Japan Ltd.  
Headquarters  
ARCO Tower 15F  
1-8-1, Shimo-Meguro, Meguro-ku,  
Tokyo 153-0064, Japan  
0120 191014 or +81 3 5437 9125  
support.japan@freescale.com

### **Asia/Pacific:**

Freescale Semiconductor Hong Kong Ltd.  
Technical Information Center  
2 Dai King Street  
Tai Po Industrial Estate  
Tai Po, N.T., Hong Kong  
+800 2666 8080  
support.asia@freescale.com

### **For Literature Requests Only:**

Freescale Semiconductor Literature Distribution Center  
P.O. Box 5405  
Denver, Colorado 80217  
1-800-441-2447 or 303-675-2140  
Fax: 303-675-2150  
LDCForFreescaleSemiconductor@hibbertgroup.com

RoHS-compliant and/or Pb-free versions of Freescale products have the functionality and electrical characteristics of their non-RoHS-compliant and/or non-Pb-free counterparts. For further information, see <http://www.freescale.com> or contact your Freescale sales representative.

For information on Freescale's Environmental Products program, go to <http://www.freescale.com/epp>.

Information in this document is provided solely to enable system and software implementers to use Freescale Semiconductor products. There are no express or implied copyright licenses granted hereunder to design or fabricate any integrated circuits or integrated circuits based on the information in this document.

Freescale Semiconductor reserves the right to make changes without further notice to any products herein. Freescale Semiconductor makes no warranty, representation or guarantee regarding the suitability of its products for any particular purpose, nor does Freescale Semiconductor assume any liability arising out of the application or use of any product or circuit, and specifically disclaims any and all liability, including without limitation consequential or incidental damages. "Typical" parameters that may be provided in Freescale Semiconductor data sheets and/or specifications can and do vary in different applications and actual performance may vary over time. All operating parameters, including "Typicals", must be validated for each customer application by customer's technical experts. Freescale Semiconductor does not convey any license under its patent rights nor the rights of others. Freescale Semiconductor products are not designed, intended, or authorized for use as components in systems intended for surgical implant into the body, or other applications intended to support or sustain life, or for any other application in which the failure of the Freescale Semiconductor product could create a situation where personal injury or death may occur. Should Buyer purchase or use Freescale Semiconductor products for any such unintended or unauthorized application, Buyer shall indemnify and hold Freescale Semiconductor and its officers, employees, subsidiaries, affiliates, and distributors harmless against all claims, costs, damages, and expenses, and reasonable attorney fees arising out of, directly or indirectly, any claim of personal injury or death associated with such unintended or unauthorized use, even if such claim alleges that Freescale Semiconductor was negligent regarding the design or manufacture of the part.



Freescale™ and the Freescale logo are trademarks of Freescale Semiconductor, Inc. All other product or service names are the property of their respective owners. This product incorporates SuperFlash® technology licensed from SST.

© Freescale Semiconductor, Inc. 2005. All rights reserved.

DSP56F802  
Rev. 9  
01/2007

## Looking for pricing, stock, or lifecycle information?

Click below to explore more details on WIN SOURCE:

- ⊖ [View DSP56F802TA60E on WIN SOURCE](#)
- ⊖ [Freescale Semiconductor - NXP Information](#)

## Optimize Your Supply Chain with WIN SOURCE Solutions

- ✓ Global Sourcing Solution
- ✓ Obsolete Management
- ✓ Cost Control Management
- ✓ Shortage Management
- ✓ Alternative Solution
- ✓ Excess Inventory Management