



# THE DATASHEET OF DSO-8-3



# LIN Transceiver

## TLE 6259-2

Automotive and  
Industrial



Never stop thinking.

# Single-Wire-Transceiver

# TLE 6259-2

## Final Datasheet

### 1 Overview

#### 1.1 Features

- Single-wire transceiver, suitable for **LIN** protocol
- Transmission rate up to 20 kBaud
- Compatible to LIN specification 1.2
- Compatible to ISO 9141 functions
- Very low current consumption in sleep mode
- Control output for voltage regulator
- Bus short to GND protection
- Short circuit proof to ground and battery
- Overtemperature protection

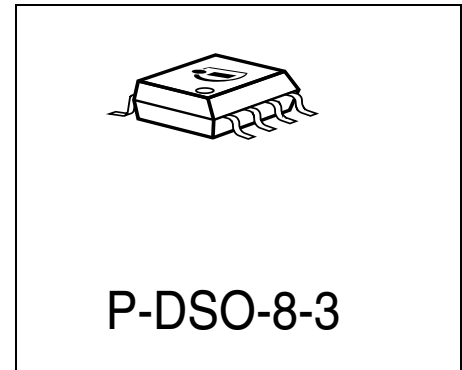

Type	Ordering Code	Package
TLE 6259-2G	Q 67006 - A 9596	P-DSO-8-3

### Description

The TLE 6259-2 is a monolithic integrated circuit in a P-DSO-8-3 package. It works as an interface between the protocol controller and the physical bus. The TLE 6259-2 is especially suitable to drive the bus line in LIN systems in automotive and industrial applications. Further it can be used in standard ISO9141 systems. The TLE6259-2 has a BUS short to GND feature implemented, to avoid a battery discharge.

In order to reduce the current consumption, the TLE 6259-2 offers a sleep operation mode. In this mode a voltage regulator can be controlled to minimize the current consumption of the whole application. A wake-up caused by a message on the bus, enables the voltage regulator and sets the RxD output LOW until the device is switched to normal operation mode.

The IC is based on the Smart Power Technology SPT® which allows bipolar and CMOS control circuitry in accordance with DMOS power devices existing on the same monolithic circuit.

The TLE 6259-2 is designed to withstand the severe conditions of automotive applications.

### 1.2 Pin Configuration (top view)

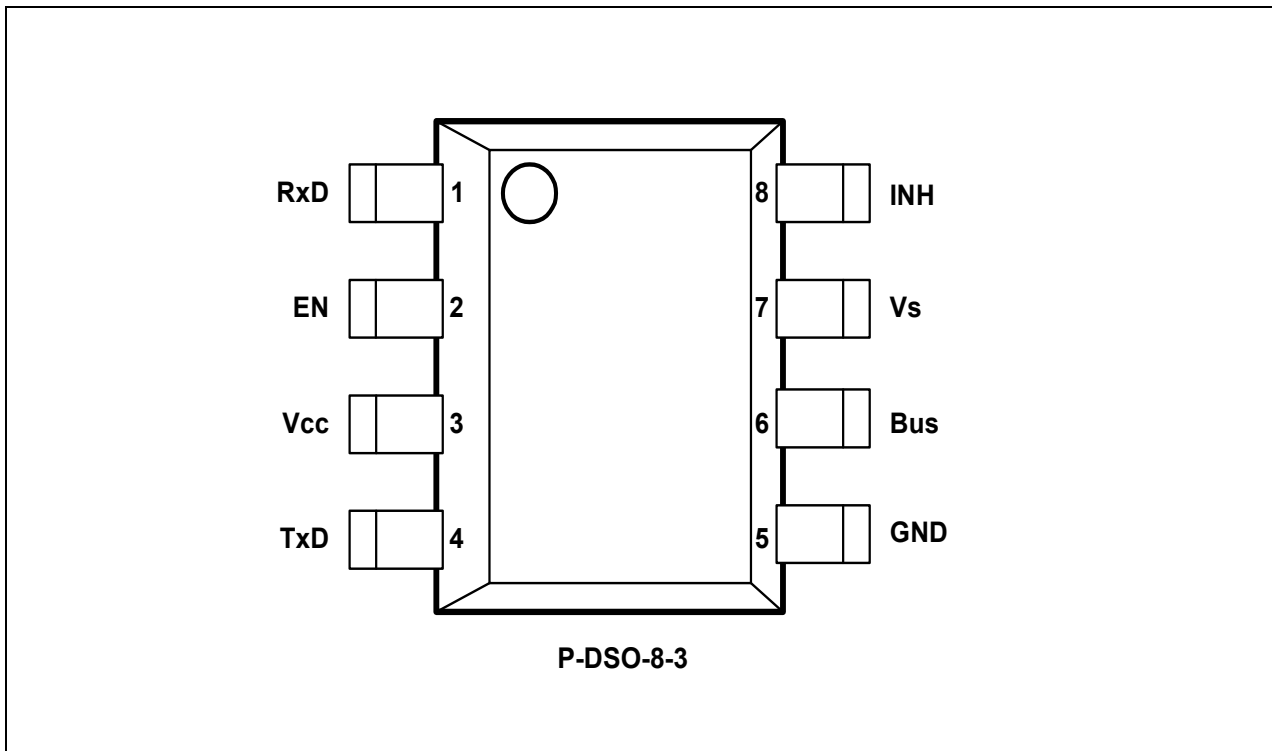

Figure 1

### 1.3 Pin Definitions and Functions:

Pin No.	Symbol	Function
1	RxD	<b>Receive data output</b> ; integrated pull up, LOW in dominant state,
2	EN	<b>Enable input</b> ; integrated 30 kΩ pull down, transceiver in normal operation mode when HIGH
3	V <sub>CC</sub>	<b>5V supply input</b> ;
4	TxD	<b>Transmit data input</b> ; integrated pull up, LOW in dominant state
5	GND	<b>Ground</b> ;
6	Bus	<b>Bus output/input</b> ; internal 30 kΩ pull up, LOW in dominant state
7	V <sub>s</sub>	<b>Battery supply input</b> ;
8	INH	<b>Inhibit output</b> ; to control a voltage regulator, becomes HIGH when wake-up via LIN bus occurs

### 1.4 Functional Block Diagram

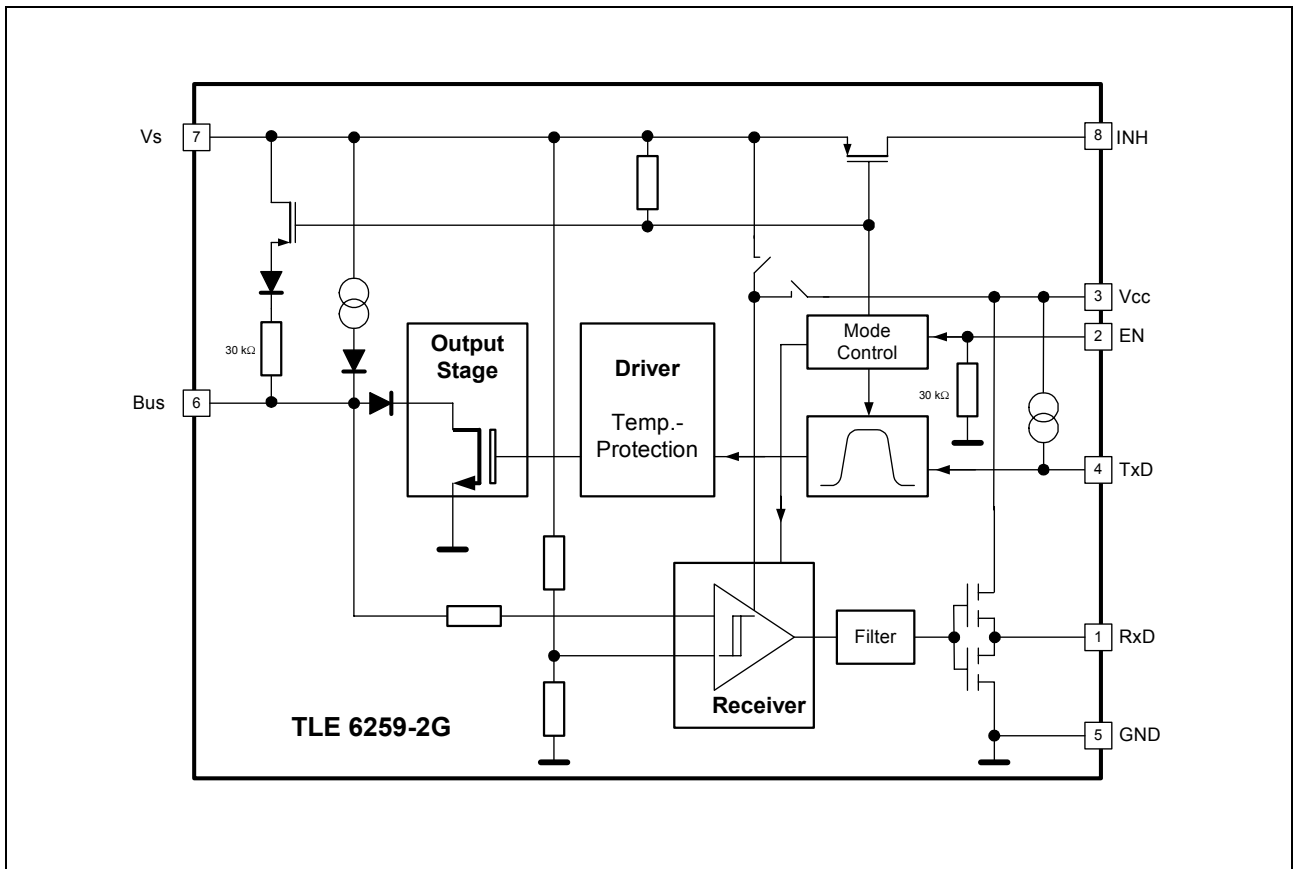
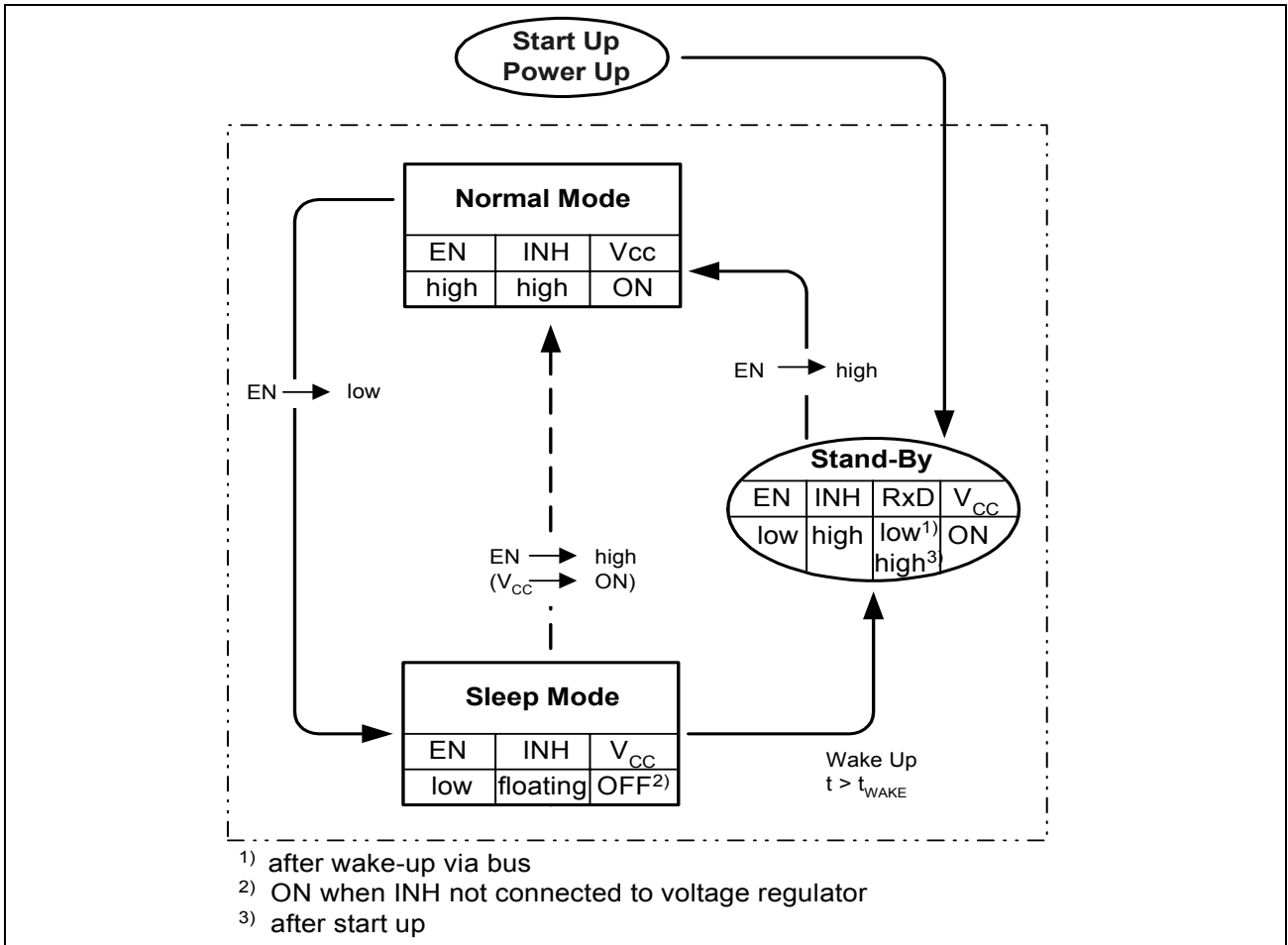

Figure 2

### 1.5 Application Information



**Figure 3: operation mode state diagram**

#### Master Termination

For fail safe reasons, the TLE6259-2 already has a pull up resistor of 30kΩ implemented. To achieve the required timings for the dominant to recessive transition of the bus signal an additional external termination resistor of 1kΩ is required. It is recommended to place this resistor in the master node. To avoid reverse currents from the bus line into the battery supply line in case of an unpowered node, it is recommended to place a diode in series to the external pull up. For small systems (low bus capacitance) the EMC performance of the system is supported by an additional capacitor of at least 1nF in the master node (see figure 6 and 7, application circuit).

#### External Capacitors

An capacitor of 22μF at the supply voltage input V<sub>S</sub> buffers the input voltage. In combination with the required reverse polarity diode this prevents the device from detecting power down conditions in case of negative transients on the supply line.

The 100nF capacitors close to the  $V_S$  pins of the 6259-2 and the voltage regulator help to improve the EMC behavior of the system.

### **Sleep Mode**

In order to reduce the current consumption the TLE 6259-2 offers a sleep operation mode. This mode is selected by switching the enable input EN low (see figure 3, state diagram). In the sleep mode, a voltage regulator can be controlled via the INH output in order to minimize the current consumption of the whole application. A wake-up caused by a message on the communication bus, automatically enables the voltage regulator by switching the INH output high. In parallel the wake-up is indicated by setting the RxD output LOW. When entering the normal mode this wake-up flag is reset and the RxD output is released to transmit the bus data.

In case the voltage regulator control input is not connected to INH output or the microcontroller is active respectively, the TLE6259-2 can be set in normal operation mode without a wake-up via the communication bus.

### **Bus Short to GND Feature**

The TLE6259-2 also has a BUS short to GND feature implemented, in order to protect the battery from running out of charge. A normal master termination connection like described above, 1k $\Omega$  resistor and diode between bus and  $V_S$ , would cause a constantly drawn current via this path. The resulting resistance of this short to GND is lower than 1k $\Omega$ . To avoid this current during a generator off state, like a parked car, the sleep mode has a bus short to GND feature implemented in the 6259-2. This feature is only applicable, if the master termination is connected with the INH pin, instead of the  $V_S$ . For a more detailed information see the application circuit in figure 6 and 7.

## 2 Electrical Characteristics

### 2.1 Absolute Maximum Ratings

Parameter	Symbol	Limit Values		Unit	Remarks
		min.	max.		

#### Voltages

Supply voltage	$V_{CC}$	-0.3	6	V	
Battery supply voltage	$V_S$	-0.3	40	V	
Bus input voltage	$V_{bus}$	-20	32	V	
Bus input voltage	$V_{bus}$	-20	40	V	$t < 1s$
Logic voltages at EN, TxD, RxD	$V_I$	-0.3	$V_{CC} + 0.3$	V	$0 V < V_{CC} < 5.5 V$
Input voltages at INH	$V_{INH}$	-0.3	$V_S + 0.3$	V	
Output current at INH	$I_{INH}$		20	mA	
Electrostatic discharge voltage at Vs, Bus	$V_{ESD}$	-4	4	kV	human body model (100 pF via 1.5 kΩ)
Electrostatic discharge voltage	$V_{ESD}$	-2	2	kV	human body model (100 pF via 1.5 kΩ)
<b>Temperatures</b>					
Junction temperature	$T_j$	-40	150	°C	–

*Note: Maximum ratings are absolute ratings; exceeding any one of these values may cause irreversible damage to the integrated circuit.*

## 2.2 Operating Range

Parameter	Symbol	Limit Values		Unit	Remarks
		min.	max.		
Supply voltage	$V_{CC}$	4.5	5.5	V	
Battery Supply Voltage	$V_S$	6	35	V	
Junction temperature	$T_j$	- 40	150	°C	-

### Thermal Resistances

Junction ambient	$R_{thj-a}$	-	185	K/W	-
------------------	-------------	---	-----	-----	---

### Thermal Shutdown (junction temperature)

	Symbol	Limit Values			Unit
		min.	typ.	max.	
Thermal shutdown temp.	$T_{jSD}$	150	170	190	°C
Thermal shutdown hyst.	$\Delta T$	-	10	-	K

### 2.3 Electrical Characteristics

4.5 V <  $V_{CC}$  < 5.5 V; 6.0 V <  $V_S$  < 27 V;  $R_L = 500 \Omega$ ;  $V_{EN} > V_{EN,ON}$ ;  $-40 \text{ }^\circ\text{C} < T_j < 125 \text{ }^\circ\text{C}$ ; all voltages with respect to ground; positive current flowing into pin; unless otherwise specified.

Parameter	Symbol	Limit Values			Unit	Remarks
		min.	typ.	max.		

#### Current Consumption

Current consumption in Normal Mode	$I_{CC}$		0.3	0,7	mA	recessive state; $V_{TxD} = V_{CC}$
			0.4	0.8	mA	dominant state; $V_{TxD} = 0 \text{ V}$
	$I_S$		0.8	1.5	mA	recessive state, without $R_{load}$ ; $V_{TxD} = V_{CC}$
			1.3	2	mA	dominant state, without $R_{load}$ ; $V_{TxD} = 0 \text{ V}$
Current consumption in Standby Mode	$I_{CC}$		3	10	$\mu\text{A}$	external VR activated INH=H
	$I_S$		18	30	$\mu\text{A}$	
Current consumption in Sleep Mode	$I_{CC}$		-	-	$\mu\text{A}$	external VR deactivated INH=L
	$I_S$		18	30	$\mu\text{A}$	

### 2.3 Electrical Characteristics (cont'd)

4.5 V < V<sub>CC</sub> < 5.5 V; 6.0 V < V<sub>S</sub> < 27 V; R<sub>L</sub> = 500 Ω; V<sub>EN</sub> > V<sub>EN,ON</sub>; -40 °C < T<sub>j</sub> < 125 °C; all voltages with respect to ground; positive current flowing into pin; unless otherwise specified.

Parameter	Symbol	Limit Values			Unit	Remarks
		min.	typ.	max.		

#### Receiver Output R×D

HIGH level output current	I <sub>RD,H</sub>	-1.2	-0.8	-0.5	mA	V <sub>RD</sub> = 0.8 × V <sub>CC</sub> ,
LOW level output current	I <sub>RD,L</sub>	0.5	0.8	1.2	mA	V <sub>RD</sub> = 0.2 × V <sub>CC</sub> ,

#### Transmission Input T×D

HIGH level input voltage threshold	V <sub>TD,H</sub>		2.9	0.7 × V <sub>CC</sub>	V	recessive state
TxD input hysteresis	V <sub>TD,hys</sub>	300	700	900	mV	
LOW level input voltage threshold	V <sub>TD,L</sub>	0.3 × V <sub>CC</sub>	2.1		V	dominant state
TxD pull up current	I <sub>TD</sub>	-150	-110	-70	μA	V <sub>TxD</sub> < 0.3V <sub>CC</sub>

#### Enable input (pin EN)

HIGH level input voltage threshold	V <sub>EN,on</sub>		2.8	0.7 × V <sub>CC</sub>	V	normal mode
LOW level input voltage threshold	V <sub>EN,off</sub>	0.3 × V <sub>CC</sub>	2.2		V	low power mode
EN input hysteresis	V <sub>EN,hys</sub>	300	600	900	mV	
EN pull down resistance	R <sub>EN</sub>	15	30	60	kΩ	

#### Inhibit output (pin INH)

Inhibit R <sub>on</sub> resistance	R <sub>onINH</sub>		65	120	Ω	I <sub>INH</sub> = - 15 mA
Leakage current	I <sub>INH,lk</sub>	- 5.0		5.0	μA	sleep mode; V <sub>INH</sub> = 0 V

### 2.3 Electrical Characteristics (cont'd)

4.5 V < V<sub>CC</sub> < 5.5 V; 6.0 V < V<sub>S</sub> < 27 V; R<sub>L</sub> = 500 Ω; V<sub>EN</sub> > V<sub>EN,ON</sub>; -40 °C < T<sub>j</sub> < 125 °C; all voltages with respect to ground; positive current flowing into pin; unless otherwise specified.

Parameter	Symbol	Limit Values			Unit	Remarks
		min.	typ.	max.		

#### Bus receiver

Receiver threshold voltage, recessive to dominant edge	V <sub>bus,rd</sub>	0.44 x V <sub>S</sub>	0.5 x V <sub>S</sub>		V	-8V < V <sub>bus</sub> < V <sub>bus,dom</sub>
Receiver threshold voltage, dominant to recessive edge	V <sub>bus,dr</sub>		0.56 x V <sub>S</sub>	0.6 x V <sub>S</sub>	V	V <sub>bus,rec</sub> < V <sub>bus</sub> < 20 V
Receiver hysteresis	V <sub>bus,hys</sub>	0.02 x V <sub>S</sub>	0.04 x V <sub>S</sub>	0.1 x V <sub>S</sub>	mV	V <sub>bus,hys</sub> = V <sub>bus,rec</sub> - V <sub>bus,dom</sub>
wake-up threshold voltage	V <sub>wake</sub>	0.40 x V <sub>S</sub>	0.5 x V <sub>S</sub>	0.6 x V <sub>S</sub>	V	

#### Bus transmitter

Bus recessive output voltage	V <sub>bus,rec</sub>	0.9 x V <sub>S</sub>		V <sub>S</sub>	V	V <sub>TxD</sub> = V <sub>CC</sub>
Bus dominant output voltage	V <sub>bus,dom</sub>			0.15 x V <sub>S</sub>	V	V <sub>TxD</sub> = 0 V; 8V < V <sub>S</sub> < 27V
				1.2	V	6V < V <sub>S</sub> < 8V
Bus short circuit current	I <sub>bus,sc</sub>	40	100	150	mA	V <sub>bus,short</sub> = 13.5 V
Leakage current	I <sub>bus,lk</sub>	-150	-70		μA	V <sub>CC</sub> = 0 V, V <sub>S</sub> = 0 V, V <sub>bus</sub> = -8 V
			10	25	μA	V <sub>CC</sub> = 0 V, V <sub>S</sub> = 0 V, V <sub>bus</sub> = 20 V
				10	μA	V <sub>LIN</sub> = V <sub>S</sub> = 13.5V
Bus pull up resistance	R <sub>bus</sub>	20	30	47	kΩ	Normal mode
Lin output current	I <sub>lin</sub>	5	30	60	μA	Sleep mode

### 2.3 Electrical Characteristics (cont'd)

4.5 V < V<sub>CC</sub> < 5.5 V; 6.0 V < V<sub>S</sub> < 27 V; R<sub>L</sub> = 500 Ω; V<sub>EN</sub> > V<sub>EN,ON</sub>; -40 °C < T<sub>j</sub> < 125 °C; all voltages with respect to ground; positive current flowing into pin; unless otherwise specified.

Parameter	Symbol	Limit Values			Unit	Remarks
		min.	typ.	max.		

#### Dynamic Transceiver Characteristics

Slope fall time	t <sub>fslope</sub>			22,5	μs	100% > V <sub>bus</sub> > 0% C <sub>bus</sub> = 10 nF; R <sub>L</sub> = 500Ω V <sub>CC</sub> = 5 V; V <sub>S</sub> = 13.5 V
Slope rise time	t <sub>rslope</sub>			22,5	μs	0% > V <sub>bus</sub> > 10 0% C <sub>bus</sub> = 10 nF; R <sub>L</sub> = 500Ω V <sub>CC</sub> = 5 V; V <sub>S</sub> = 13.5 V
Slope symmetry	t <sub>slopesym</sub>	-5		5	μs	t <sub>fslope</sub> - t <sub>rslope</sub>
Slope fall time	t <sub>fslope</sub>			22.5	μs	100% > V <sub>bus</sub> > 0% C <sub>bus</sub> = 6,8nF; R <sub>L</sub> = 660Ω T <sub>ambient</sub> < 85 °C; V <sub>CC</sub> = 5 V; V <sub>S</sub> = 13.5 V
Slope rise time	t <sub>rslope</sub>			22.5	μs	0% > V <sub>bus</sub> > 100% C <sub>bus</sub> = 6,8nF; R <sub>L</sub> = 660Ω V <sub>CC</sub> = 5 V; V <sub>S</sub> = 13.5 V
Slope symmetry	t <sub>slopesym</sub>	-4		4	μs	t <sub>fslope</sub> - t <sub>rslope</sub>
Propagation delay TxD LOW to bus	t <sub>d(L),T</sub>		1	3	μs	V <sub>CC</sub> = 5 V
Propagation delay TxD HIGH to bus	t <sub>d(H),T</sub>		1	3	μs	V <sub>CC</sub> = 5 V
Propagation delay bus dominant to RxD LOW	t <sub>d(L),R</sub>		1	6	μs	V <sub>CC</sub> = 5V; C <sub>RxD</sub> = 20pF
Propagation delay bus recessive to RxD HIGH	t <sub>d(H),R</sub>		1	6	μs	V <sub>CC</sub> = 5 V; C <sub>RxD</sub> = 20 pF
Receiver delay symmetry	t <sub>sym,R</sub>	-2		2	μs	t <sub>sym,R</sub> = t <sub>d(L),R</sub> - t <sub>d(H),R</sub>
Transmitter delay symmetry	t <sub>sym,T</sub>	-2		2	μs	t <sub>sym,T</sub> = t <sub>d(L),T</sub> - t <sub>d(H),T</sub>
Wake-up delay time	t <sub>wake</sub>	30	100	150	μs	T <sub>j</sub> ≤ 125°
				170	μs	T <sub>j</sub> ≤ 150°
Delay time for change sleep/ stand by mode-normal mode	t <sub>snorm</sub>			10	μs	
Delay time for change normal mode - sleep mode	t <sub>nsleep</sub>			10	μs	

### 3 Diagrams

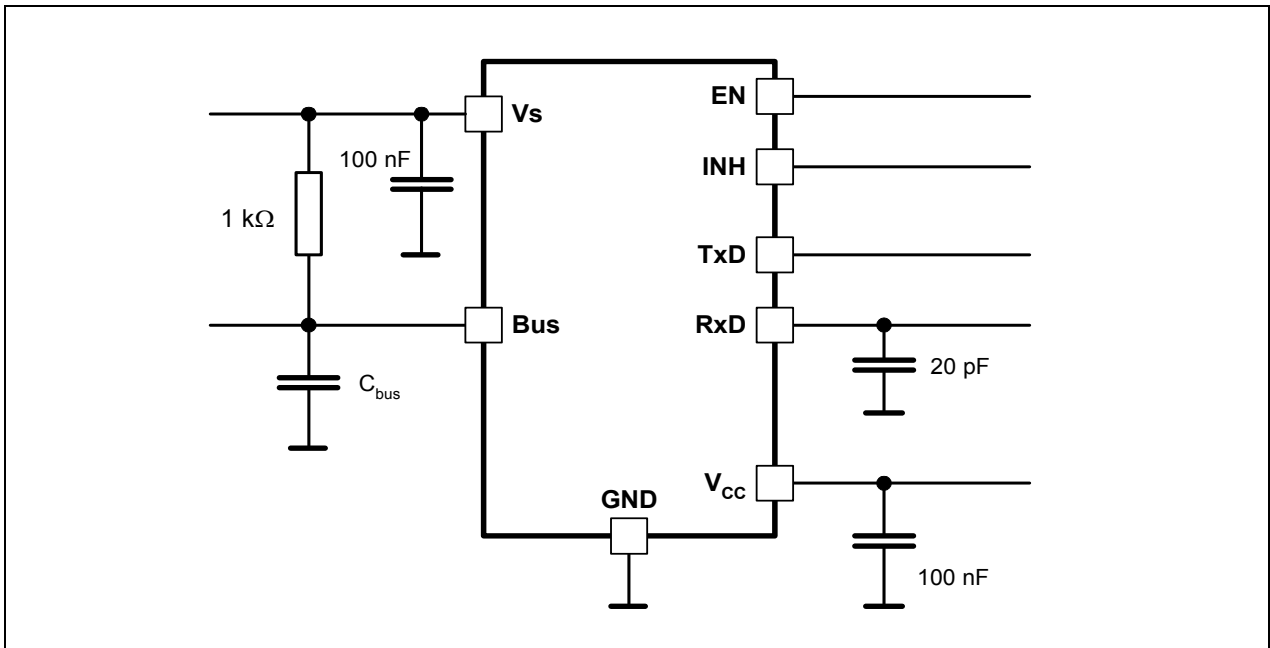

Figure 4: Test circuits

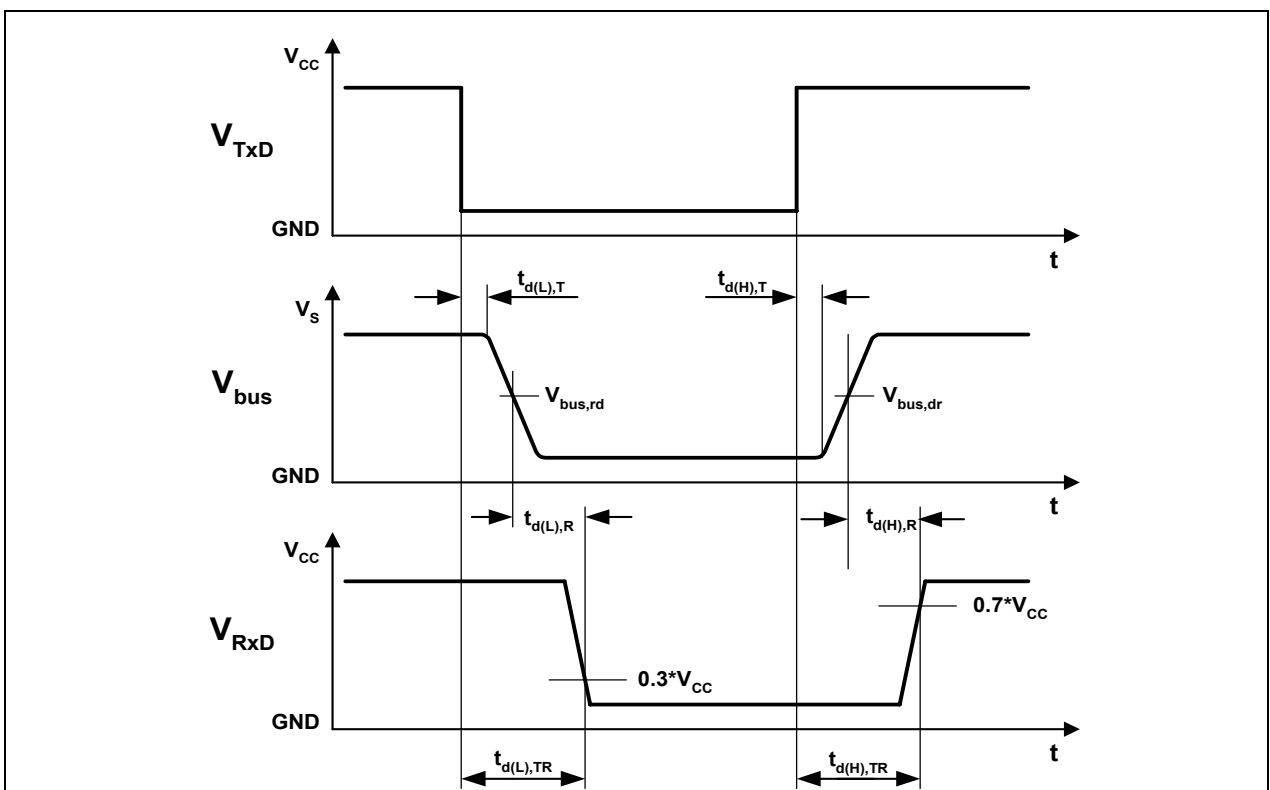
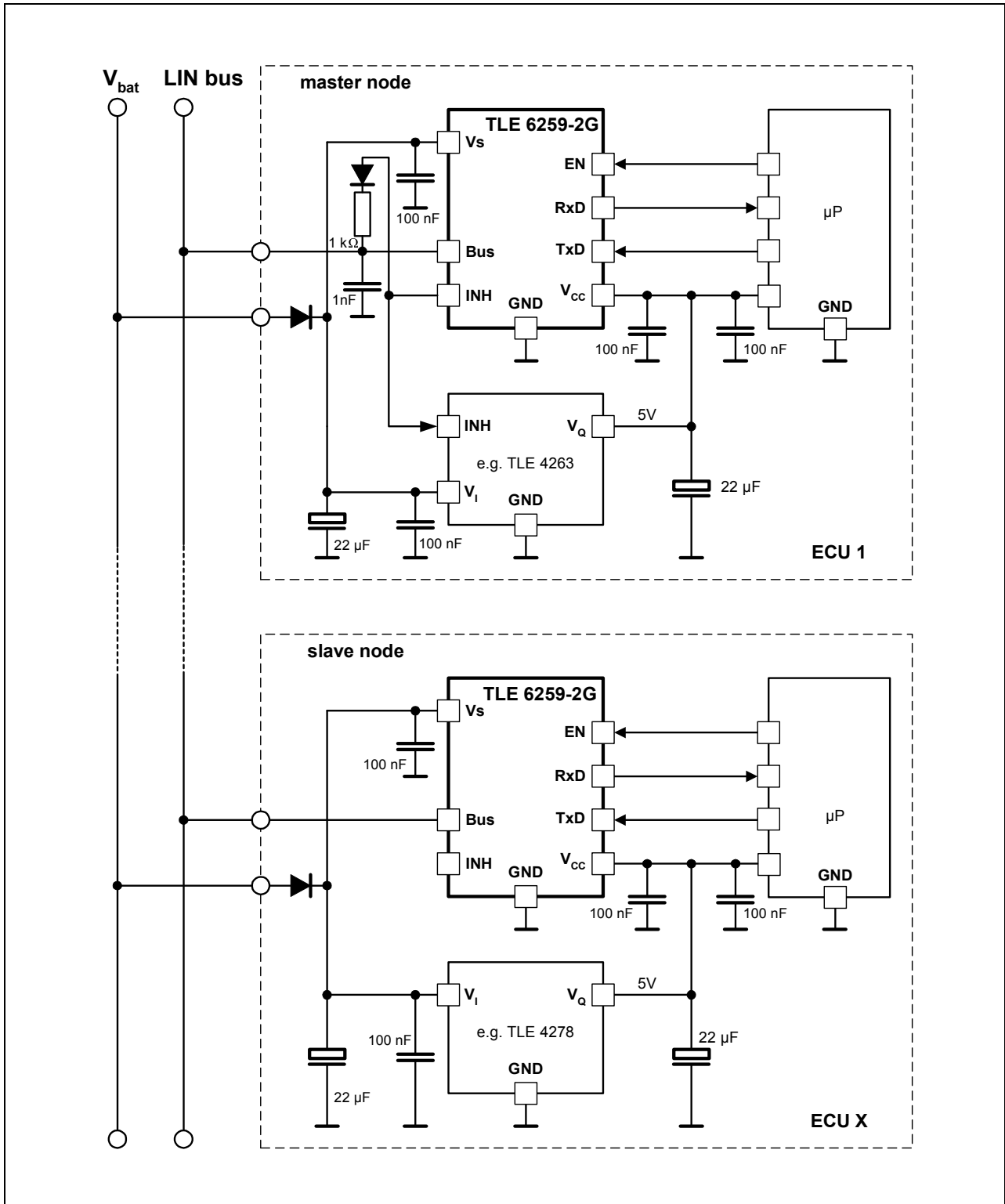
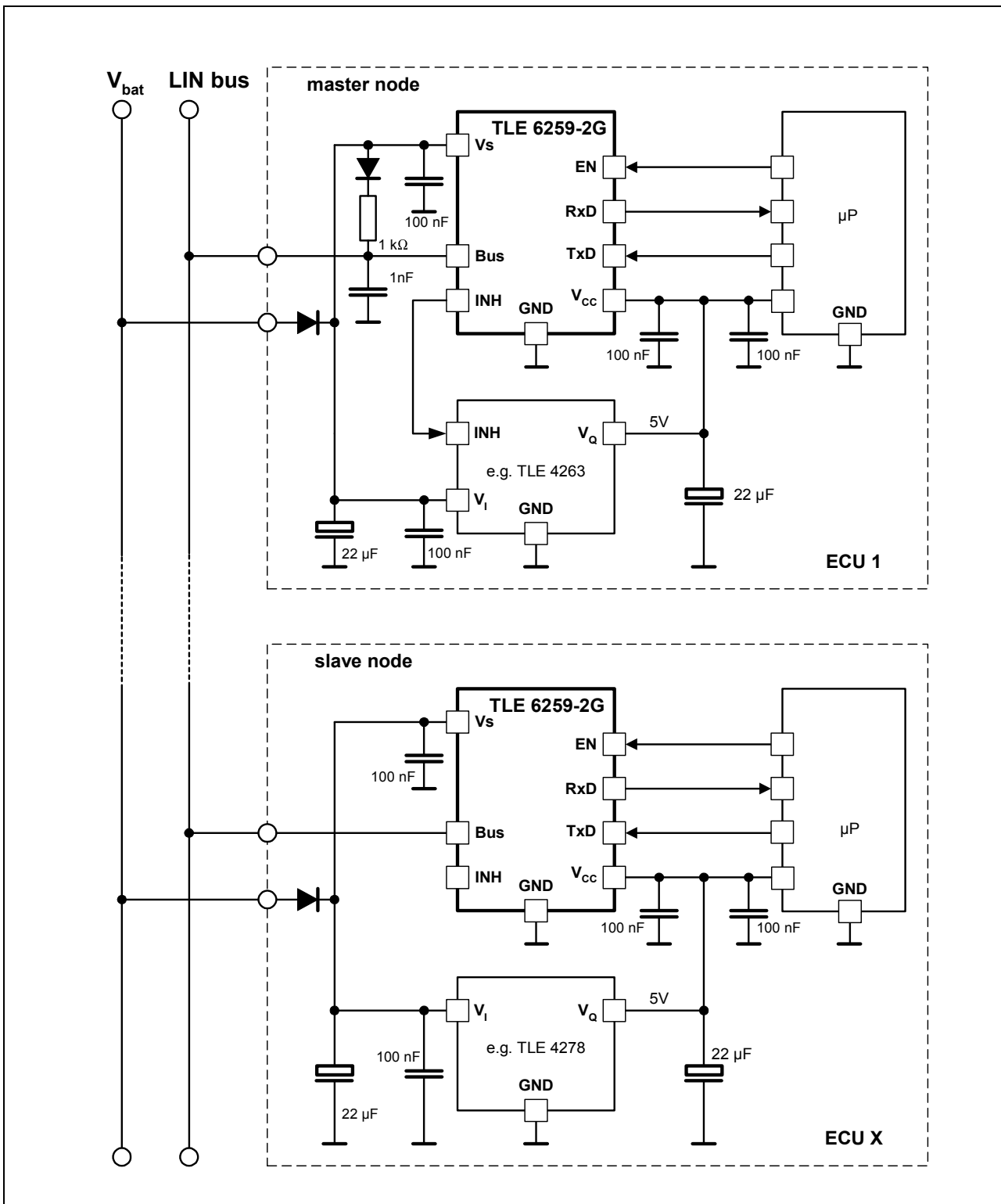

Figure 5: Timing diagrams for dynamic characteristics

## 4 Application



**Figure 6**  
Application circuit with bus short to GND feature applied

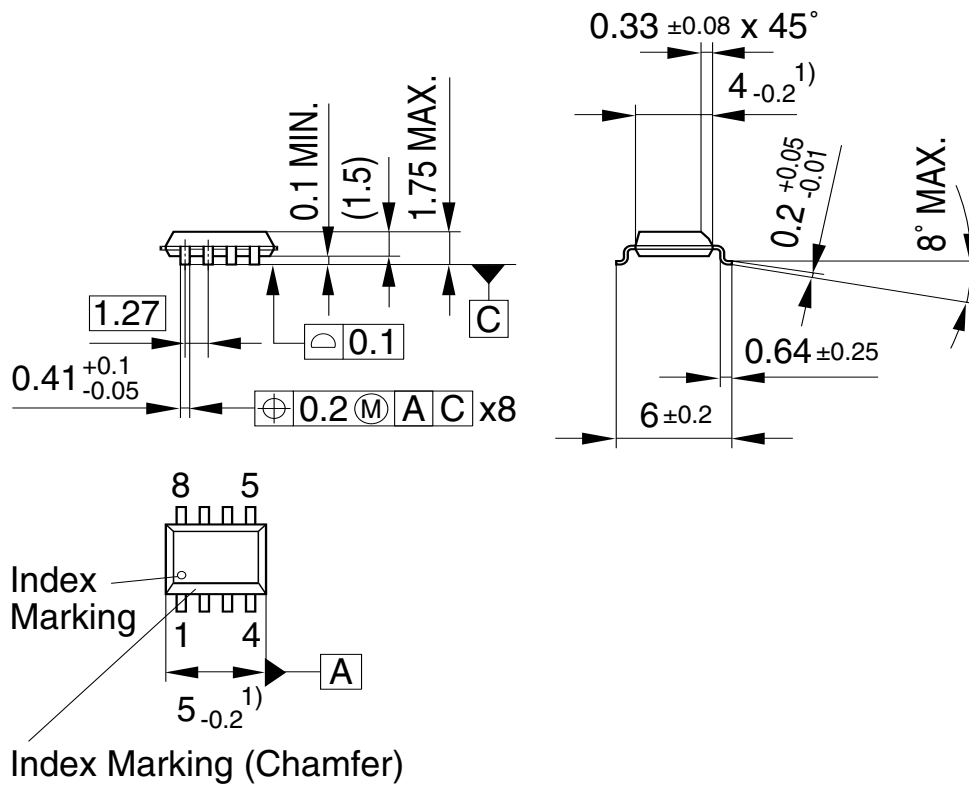

**Figure 7**  
Application circuit without bus short to GND feature

## 5 Package Outlines

### P-DSO-8-3

(Plastic Dual Small Outline Package)



<sup>1)</sup> Does not include plastic or metal protrusion of 0.15 max. per side

### Sorts of Packing

Package outlines for tubes, trays etc. are contained in our Data Book "Package Information".

SMD = Surface Mounted Device

Dimensions in mm

**Edition 1999-10-12**

**Published by Infineon Technologies AG**

**St.-Martin-Strasse 53**

**D-81541 München**

**© Infineon Technologies AG1999**

**All Rights Reserved.**

**Attention please!**

The information herein is given to describe certain components and shall not be considered as warranted characteristics.

Terms of delivery and rights to technical change reserved.

We hereby disclaim any and all warranties, including but not limited to warranties of non-infringement, regarding circuits, descriptions and charts stated herein.

Infineon Technologies is an approved CECC manufacturer.

**Information**

For further information on technology, delivery terms and conditions and prices please contact your nearest Infineon Technologies Office in Germany or our Infineon Technologies Representatives worldwide (see address list).

**Warnings**

Due to technical requirements components may contain dangerous substances. For information on the types in question please contact your nearest Infineon Technologies Office.

Infineon Technologies Components may only be used in life-support devices or systems with the express written approval of Infineon Technologies, if a failure of such components can reasonably be expected to cause the failure of that life-support device or system, or to affect the safety or effectiveness of that device or system. Life support devices or systems are intended to be implanted in the human body, or to support and/or maintain and sustain and/or protect human life. If they fail, it is reasonable to assume that the health of the user or other persons may be endangered.

## Infineon goes for Business Excellence

“Business excellence means intelligent approaches and clearly defined processes, which are both constantly under review and ultimately lead to good operating results.

Better operating results and business excellence mean less idleness and wastefulness for all of us, more professional success, more accurate information, a better overview and, thereby, less frustration and more satisfaction.”



Dr. Ulrich Schumacher

<http://www.infineon.com>

Published by Infineon Technologies AG

## Looking for pricing, stock, or lifecycle information?

Click below to explore more details on WIN SOURCE:

-  [View DSO-8-3 on WIN SOURCE](#)
-  [Infineon Technologies Information](#)

## Optimize Your Supply Chain with WIN SOURCE Solutions

-  Global Sourcing Solution
-  Obsolete Management
-  Cost Control Management
-  Shortage Management
-  Alternative Solution
-  Excess Inventory Management