

DESCRIPTION

The IF-D92 is a high-sensitivity NPN phototransistor detector housed in a “connector-less” style plastic fiber optic package. Optical response of the IF-D92 extends from 400 to 1100 nm, making it compatible with a wide range of visible and near-infrared LEDs and laser diode sources. This includes 650 nm visible red LEDs used for optimum transmission in PMMA plastic optical fiber. The detector package features an internal micro-lens and a precision-molded PBT housing to ensure efficient optical coupling with standard 1000 μm core plastic fiber cable.

APPLICATION HIGHLIGHTS

The IF-D92 is suitable for digital data links at rates up to 20 kbps. Analog bandwidths greater than 15 kHz are possible making the IF-D92 usable for high frequency audio transmission. Phototransistor operation provides high internal gain – reducing the amount of post-amplification required in many circuits. The integrated design of the IF-D92 makes it a simple, cost-effective solution in a variety of analog and digital applications.

APPLICATIONS

- Low-Speed Digital Data Links
- Motor Controller Triggering
- Audio Links
- Medical Instruments
- Automotive Electronics
- Robotics Communications
- EMC/EMI Signal Isolation
- Electronic Games
- Process Control

FEATURES

- ◆ High Optical Sensitivity
- ◆ Mates with Standard 1000 um Core, 2.2 mm Jacketed Plastic Fiber Optic Cable
- ◆ Mates with 2.2 mm Jacketed Multimode Glass Fiber, 200/230 or 400/430 using Active Device Adapter – 51 0537; 51 0538
- ◆ No Optical Design Required
- ◆ Inexpensive but Rugged Plastic Connector Housing
- ◆ Internal Micro-Lens for Efficient Optical Coupling
- ◆ Connector-Less Fiber Termination
- ◆ Light-Tight Housing provides Interference Free Transmission
- ◆ RoHS Compliant

MAXIMUM RATINGS

($T_A = 25^\circ\text{C}$)
 Operating and Storage Temperature Range (TOP, TSTG)..... -40° to 85°C
 Junction Temperature (T_J)..... 85°C
 Soldering Temperature (2 mm from case bottom) (T_S) $t \leq 5$ s..... 240°C
 Collector Emitter Voltage (V_{CEO}).....30 V
 Emitter Collector Voltage (V_{ECO})5 V
 Collector Current (I_C).....50 mA
 Collector Peak Current (I_{CM}) $t = 1$ ms100 mA
 Power Dissipation (PTOT) $T_A = 25^\circ\text{C}$100 mW
 De-rate Above 25°C1.67 mW/ $^\circ\text{C}$

CHARACTERISTICS ($T_A = 25^\circ\text{C}$)

Parameter	Symbol	Min.	Typ.	Max.	Unit
Wavelength for Maximum Photosensitivity	λ_{PEAK}	–	870	–	nm
Spectral Bandwidth ($R=10\%$ of R_{MAX})	$\Delta\lambda$	400	–	1100	nm
Switching Times (10% to 90% and 90% to 10%) ($R_L=1$ k Ω , $I_C=1.0$ mA, $V_{CE}=5$ V, $\lambda=850$ nm)	t_r t_f	-	25 25	-	μs
Responsivity min. @ 870 nm @ 650 nm	R	-	450 350	-	$\mu\text{A}/\mu\text{W}$
Collector Dark Current ($V_{CE}=10$ volts)	I_{CEO}	–	–	100	nA
Breakdown Voltage ($I_C=100$ μA)	BV_{CEO}	30	–	–	V
Breakdown Voltage ($I_C= -100$ μA)	BV_{ECO}	5	–	–	V
Saturation Voltage ($I_C=250$ μA , $P_{in}=100$ μW)	$V_{CE sat}$	–	0.15	–	V

CAUTION: The IF D92 is ESD sensitive. To minimize risk of damage observe appropriate precautions during handling and processing.

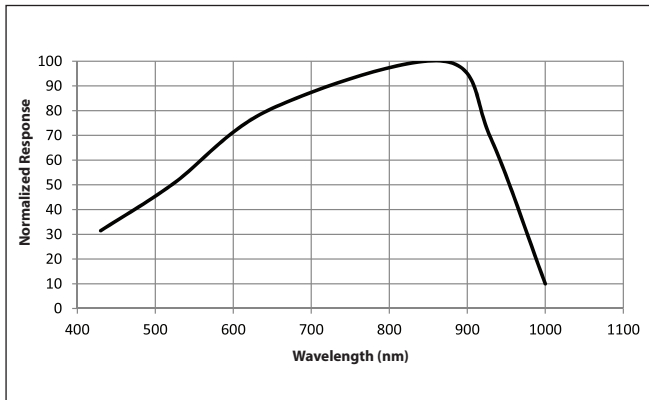

FIGURE 1. Typical detector response versus wavelength.

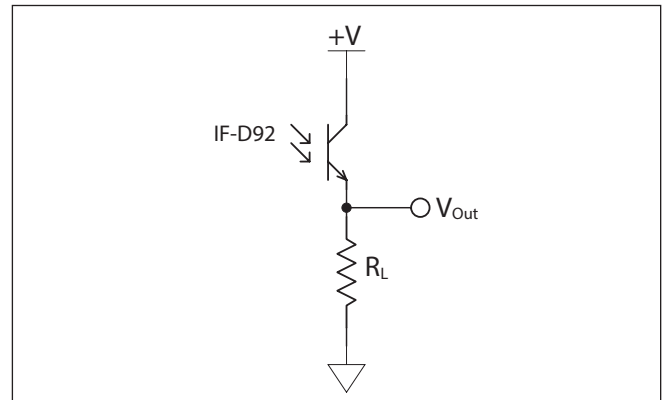

FIGURE 4A. Switching time and application circuit

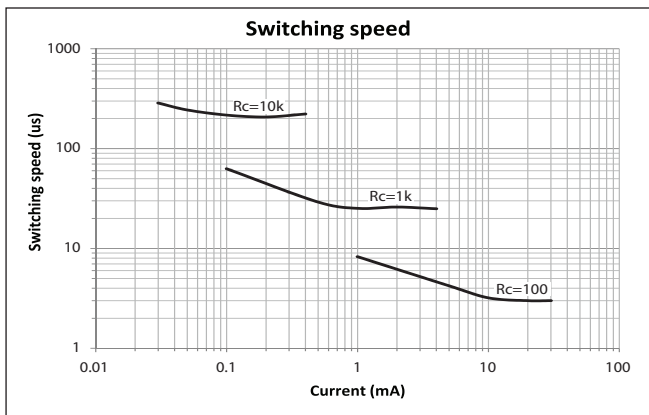

FIGURE 2. Rise and fall times of phototransistor.

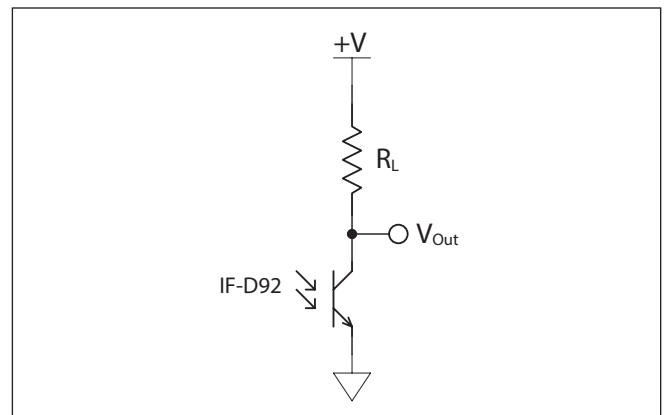

FIGURE 4B. Switching time and application circuit

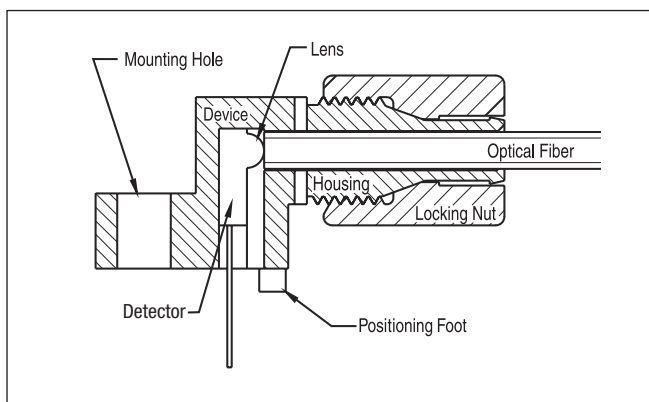

FIGURE 3. Cross-section of fiber optic device.

FIBER TERMINATION INSTRUCTIONS – PLASTIC OPTICAL FIBER

1. Cut off the ends of the optical fiber with a single-edge razor blade or sharp knife. Try to obtain a precise 90-degree angle (square).
2. Insert the fiber through the locking nut and into the connector until the core tip seats against the internal micro-lens.
3. Screw the connector locking nut down to a snug fit, locking the fiber in place. Do not exceed a torque of 0.4 N·m.

Glass fiber – Refer to instructions listed on manufacturer's data sheet for each active device adapter.

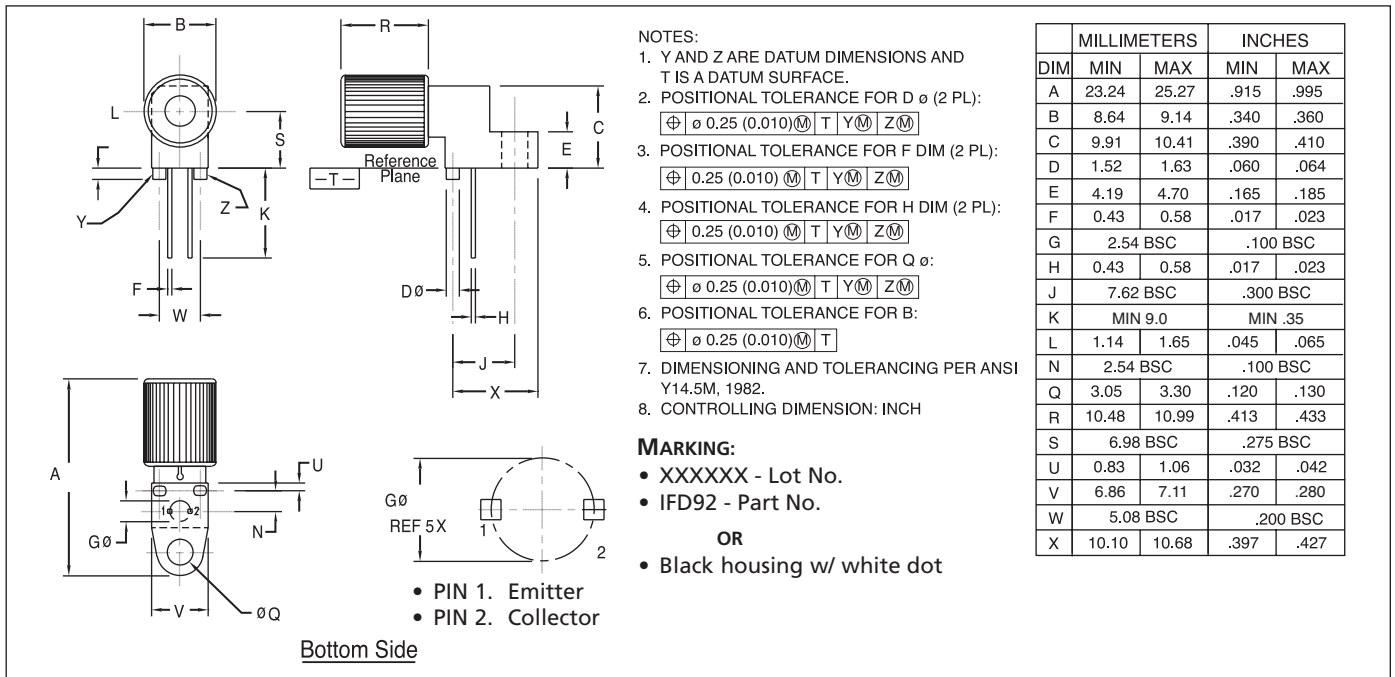

FIGURE 4. Case outline. Specifications are believed to be accurate but are subject to change. Industrial Fiber Optics assumes no responsibility for the consequences of using the information provided beyond replacement warranty for products not meeting stated specifications. Industrial Fiber Optics products are not authorized for use in life support applications without written approval from the President of Industrial Fiber Optics Corporation.

CAUTION:

- To avoid degraded device life due to package stress, do not bend or form leads outside the orientation shown on drawing.
- Ensure that solder flux does not migrate into the device and block the optical path, degrading the performance.
- If washing the device, liquid may become trapped in the part cavity. Ensure that all potentially corrosive materials are flushed out of the device.

APPLICATION NOTES

DIGITAL TRANSMISSION

The basic circuits of Figure 4 can be used for digital transmission. Figure 4A is non-inverting and Figure 4B is inverting. The output voltage for Figure 4A is $V_{OUT} = P_{in} \times R \times R_L$. Where P_{in} is the input power from the fiber, R is the responsivity of the IF-D92 at the wavelength used, and R_L is the load resistance. The output voltage for Figure 4B is $V_{out} = +V - P_{in} \times R_L$. The speed of both circuits is virtually the same.

ANALOG TRANSMISSION

Sending analog information over an optical fiber is difficult. Any small change in the loop can make the received signal level change. Transmitting digital information is much more reliable, but performing an analog to digital conversion at the transmit end and a digital to analog conversion at the receiving end can be cumbersome. Below are simple circuits for transmitting analog information. They convert the analog voltage to a frequency and then convert the frequency back to analog.

The circuit shown in Figure 5 is a basic voltage to frequency converter. It uses an LM331 voltage to frequency IC and an IF-E96E as the emitter. With the supply voltage, +V, set to 15 Volts, the input range is 0 to 10 Volts. The frequency runs from approximately 200 Hz at 0 Volts input to 9 kHz at 10 Volts input. The duty cycle also changes as the input voltage changes and variable resistor RS2 should be set so that the duty cycle does not go to 0 % or 100 % at the input extremes. Resistor R1 sets the drive current for the IF-E96E at approximately 3.3 mA. It can be changed within the current limits of the IF-E96E and the LM331. The waveform driving the output can be seen at point FOUT.

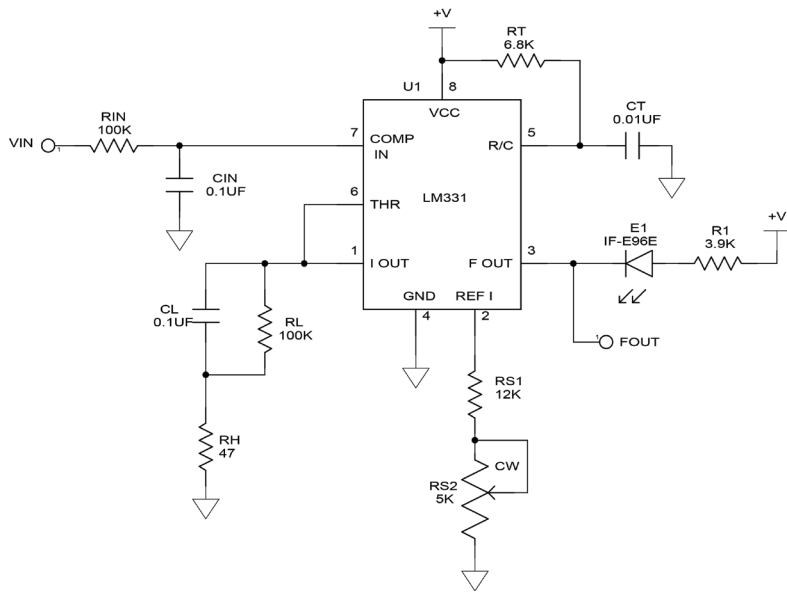

FIGURE 5. Voltage to Frequency converter

The circuit shown in Figure 6 is a basic frequency to voltage converter. It uses an LM331 voltage to frequency converter IC and an IF-D92 to detect the signal from the emitter in the circuit of Figure 5. The supply voltage, +V, should be set to 15 Volts for a 0 to 10 Volt output range. In this circuit variable resistor RS2 should be adjusted so that the output voltage tracks the voltage input into the circuit of Figure 5. The inverted received signal can be seen at point FIN.

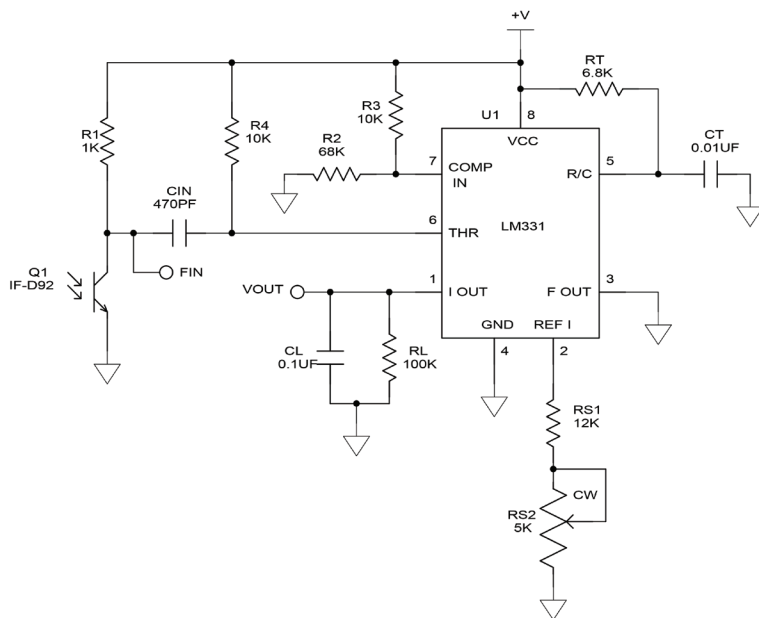

FIGURE 6. Frequency to Voltage converter

The circuits in Figures 5 and 6 work together to transmit an analog DC voltage over a fiber optic cable. The combined circuits have a response time of 50 ms (to 1%). Refer to the LM331 datasheet for more complex circuits with higher accuracy or faster response time.

Looking for pricing, stock, or lifecycle information?

Click below to explore more details on WIN SOURCE:

- [View IF-D92 on WIN SOURCE](#)
- [Industrial Fiberoptics Information](#)

Optimize Your Supply Chain with WIN SOURCE Solutions

- ✓ Global Sourcing Solution
- ✓ Obsolete Management
- ✓ Cost Control Management
- ✓ Shortage Management
- ✓ Alternative Solution
- ✓ Excess Inventory Management