

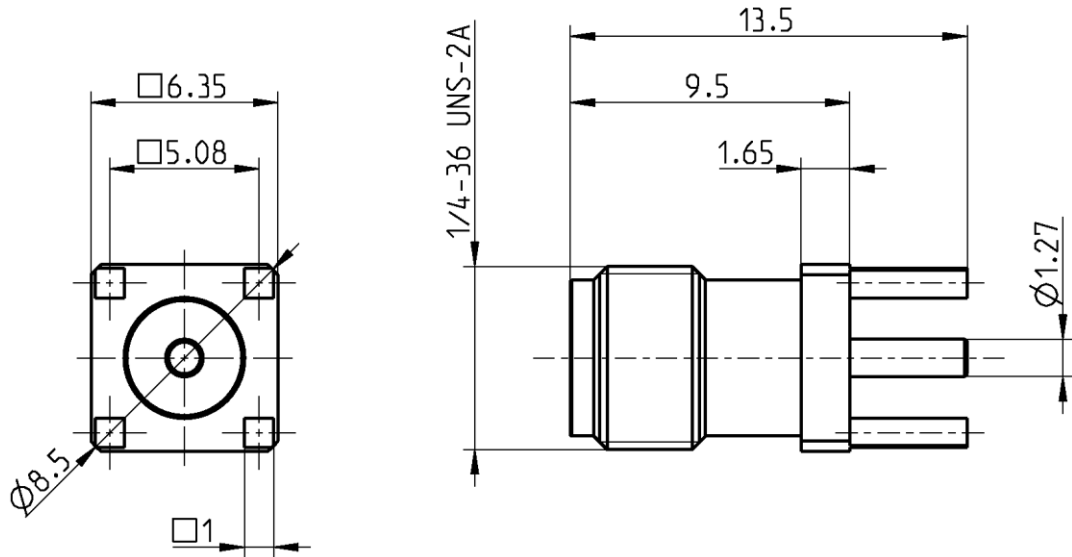

THE DATASHEET OF
32K101-400L5





All dimensions are in mm; tolerances according to ISO 2768 m-H

Interface

According to IEC 60169-15, EN 122110, MIL-STD-348A, Fig. 310

Documents

PCB layout B 30B

Material and plating

Connector parts

Center contact	CuBe
Outer contact	CuBe or equiv.
Dielectric	PTFE

Plating

AuroDur®, gold plated
AuroDur®, gold plated

Dieses Dokument ist urheberrechtlich geschützt • This document is protected by copyright • Rosenberger Hochfrequenztechnik GmbH & Co. KG

RF_35/09.14/6.2

Electrical data

Impedance	50 Ω
Frequency	DC to 18 GHz
VSWR	≤ 1.05 + 0.005 x f [GHz], DC to 8 GHz ≤ 1.30, 8 to 18 GHz
Insertion loss	≤ 0.03 x √f(GHz) dB
Insulation resistance	≥ 5 x10 ³ MΩ
Center contact resistance	≤ 3 mΩ
Outer contact resistance	≤ 2 mΩ
Test voltage	1000 V rms
Working voltage	480 V rms
Power handling (at 20 °C, sea level, VSWR 1.0)	≤ 200 W @ 2 GHz; ≤ 100 W @ 10 GHz
RF-leakage	≥ 100 dB up to 1 GHz

- VSWR in application depends decisive on PCB layout -

Mechanical data

Mating cycles	min. 500
Center contact captivation: axial	≥ 27 N
radial	≥ 3 Ncm
Coupling test torque	max. 1.7 Nm
Recommended torque	0.8 Nm to 1.1 Nm

Environmental data

Temperature range	-55°C to +155°C
Thermal shock	MIL-STD-202, Meth. 107, Cond. B
Corrosion	MIL-STD-202, Meth. 101, Cond. B
Vibration	MIL-STD-202, Meth. 204, Cond. D
Shock	MIL-STD-202, Meth. 213, Cond. I
Moisture resistance	MIL-STD-202, Meth. 106
Max. soldering temperature	IEC 61760-1, +260°C for 10 sec.
RoHS	compliant

Tooling

N/A

Suitable cables

N/A

Weight

Weight 1.4 g/pce

While the information has been carefully compiled to the best of our knowledge, nothing is intended as representation or warranty on our part and no statement herein shall be construed as recommendation to infringe existing patents. In the effort to improve our products, we reserve the right to make changes judged to be necessary.

For the installation of the electrotechnical equipment, particular electrotechnical expertise is required.



Draft	Date	Approved	Date	Rev.	Engineering change number	Name	Date
Schmid M.	08.03.07	Chr. Janßen	04.11.20	d00	20-1927	S. Huber-Siegl	04.11.20

Looking for pricing, stock, or lifecycle information?

Click below to explore more details on WIN SOURCE:

- [View 32K101-400L5 on WIN SOURCE](#)
- [Rosenberger Information](#)

Optimize Your Supply Chain with WIN SOURCE Solutions

- ✓ Global Sourcing Solution
- ✓ Obsolete Management
- ✓ Cost Control Management
- ✓ Shortage Management
- ✓ Alternative Solution
- ✓ Excess Inventory Management