



THE DATASHEET OF
0826-1A1T-43-F



THE INFORMATION CONTAINED HEREIN IS CONSIDERED "PROPRIETARY" TO BEL FUSE INC. AND SHALL NOT BE COPIED, REPRODUCED OR DISCLOSED WITHOUT THE WRITTEN APPROVAL OF BEL FUSE INC.

RoHS



LED1 POLARITY			LED2 POLARITY		
PIN 13	PIN 14	COLOR	PIN 15	PIN 16	COLOR
-	+	YELLOW	-	+	GREEN

ELECTRICAL CHARACTERISTICS @ 25°C

URNS RATIO

TP1	1CT : 1CT	±2%
TP2	1CT : 1CT	±2%
TP3	1CT : 1CT	±2%
TP4	1CT : 1CT	±2%

□CL @ 100kHz/100mVRMS

8mA DC BIAS	350µH MIN.
-------------	------------

INS. LOSS

0.1MHz TO 1MHz	-1.1 dB MAX
1MHz TO 65MHz	-0.5 dB MAX
65MHz TO 100MHz	-0.8 dB MAX
100MHz TO 125MHz	-1.2 dB MAX

RET. LOSS (MIN)

0.5MHz-40MHz	-18 dB
40MHz-100MHz	-12+20LOG(f/80MHz) dB

CROSS TALK

100kHz - 100MHz	-33+20LOG(f/100MHz)dB MIN
-----------------	---------------------------

CM TO CM REJ

100kHz - 100MHz	-30 dB MIN
-----------------	------------

CM TO DM REJ

100kHz - 100MHz	-35 dB MIN
-----------------	------------

HIPOT (Isolation Voltage):

1500 Vrms	100% OF PRODUCTION TESTED TO COMPLY WITH IEEE 802.3 ISOLATION REQUIREMENTS.
-----------	---

LED 1

VF (FORWARD VOLTAGE)	IF=20mA	YELLOW	2.1V TYP.
λD (DOMINANT WAVELENGTH)	IF=20mA	YELLOW	590nm TYP.

LED 2

VF (FORWARD VOLTAGE)	IF=20mA	GREEN	2.2V TYP.
λD (DOMINANT WAVELENGTH)	IF=20mA	GREEN	570nm TYP.

OPERATING TEMPERATURE: 0°C TO +70°C.

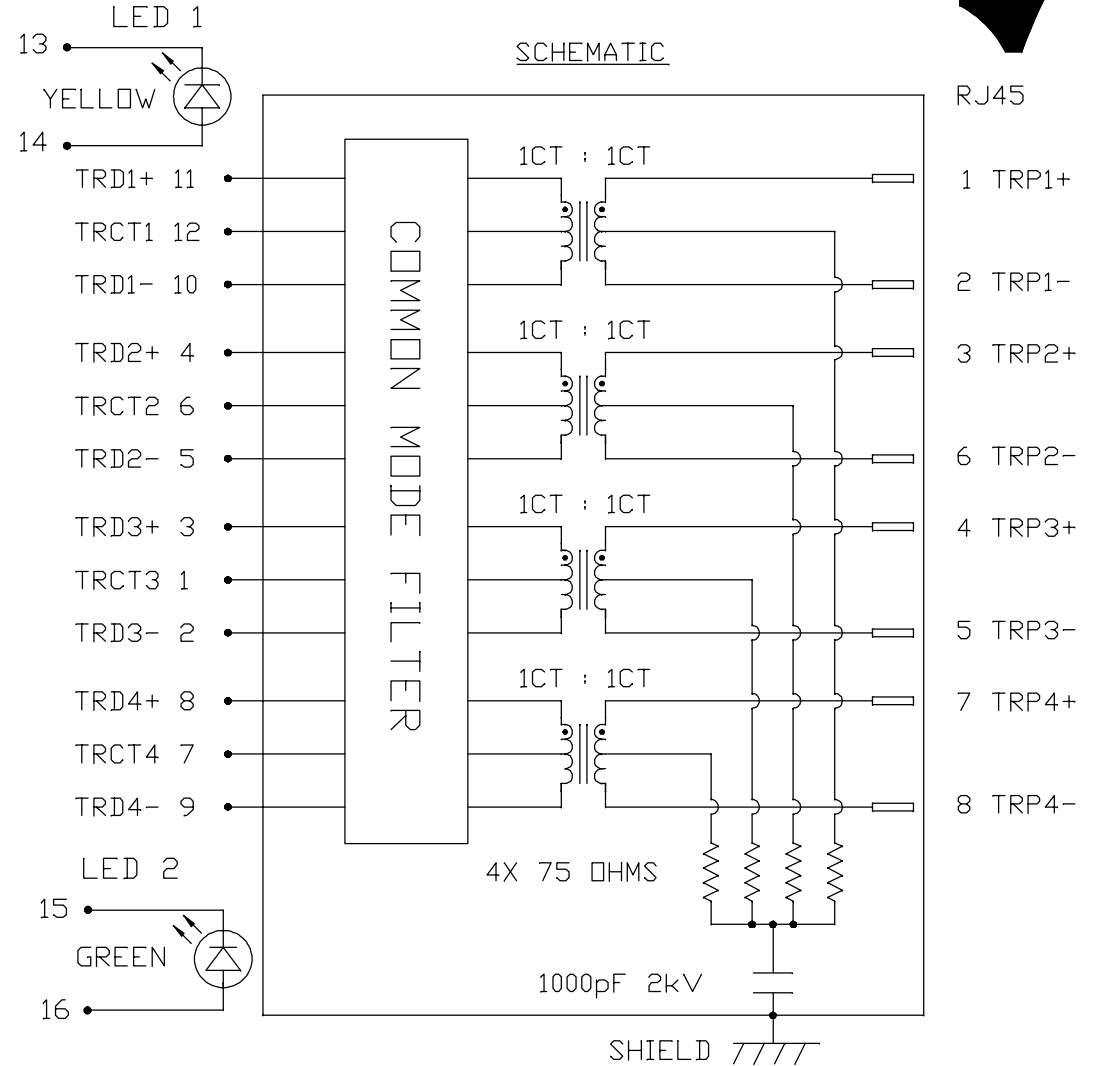

RJ45

1 TRP1+

2 TRP1-

3 TRP2+

6 TRP2-

4 TRP3+

5 TRP3-

7 TRP4+

8 TRP4-

ORIGINATED BY CHOW WANCHUNG
DATE 2016-08-09
DRAWN BY SKY YOU
DATE 2016-08-09

TITLE gigabit MagJack® (8 cores, Tab Up)
0826-1A1T-43-F PATENTED

PART NO. / DRAWING NO. 08261A1T43-F
FILE NAME 08261A1T43-F_D.DWG

STANDARD DIM. TOL. IN INCH	[] METRIC DIM. AS REF.
.X	UNIT : INCH [mm]
.XX	SCALE : N/A
.XXX	SIZE : A4

REV. : D	PAGE : 2
-----------------	-----------------



THE INFORMATION CONTAINED HEREIN IS CONSIDERED "PROPRIETARY" TO BEL FUSE INC. AND SHALL NOT BE COPIED, REPRODUCED OR DISCLOSED WITHOUT THE WRITTEN APPROVAL OF BEL FUSE INC.

MECHANICAL SPECIFICATION

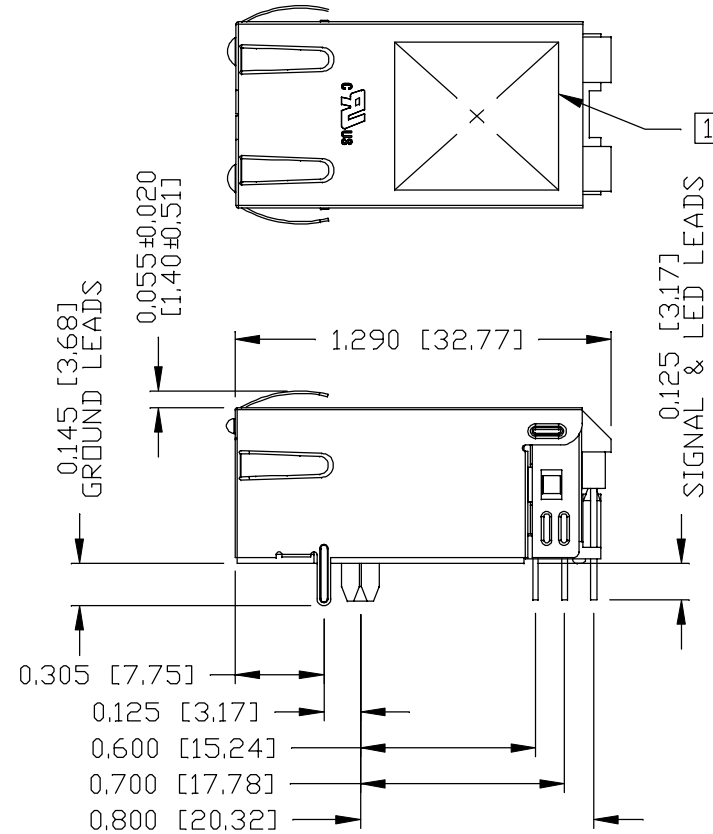
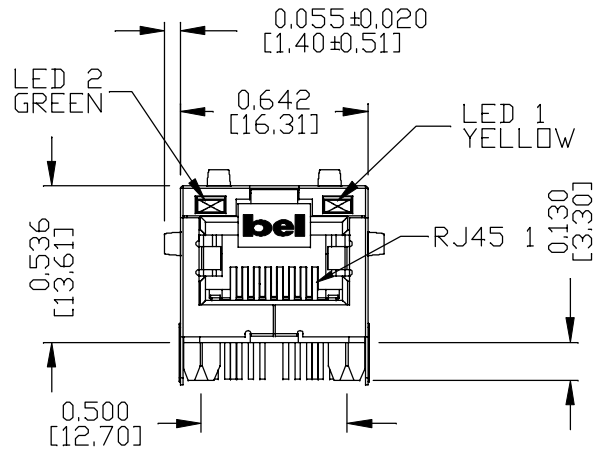

NOTES:

- PLASTIC HOUSING: THERMOPLASTIC PA, BLACK
FLAMMABILITY RATING UL 94V-0
- CONTACTS: 50 MICRO-INCH HARD GOLD PLATING OR EQUIVALENT,
30 MICRO-INCH MIN NICKEL UNDERPLATE.
- OUTPUT PINS: TIN-COATED COPPER WIRE, DIA 0.018 INCH.
100 MICRO-INCH MIN MATTE TIN. PINS ARE SOLDER DIPPED.
- METAL SHIELD: NICKEL PLATED ON COPPER ALLOY.
(ALL GROUND LEADS ARE SOLDER DIPPED)

[1] MARK PART WITH MFG LOGO, MFG NAME, PART NUMBER, DATE CODE AND PATENTED.

- 1. UL RECOGNIZED - FILE #E196366 AND E169987.
- 2. THE PRODUCT IS RoHS COMPLIANT.
- 3. JACK CAVITY CONFORMS TO FCC RULES AND REGULATIONS.
- 4. THE PRODUCT IS PATENTED. THE PATENT NUMBER IS U.S. PAT. 7,123,117.
- 5. THE PART IS RECOMMENDED FOR WAVE SOLDERING. THE SUGGESTED PEAK WAVE SOLDERING CONDITION IS 260°C MAX AND 10 SECONDS MAX.

REV. :	D	PAGE :	3
--------	---	--------	---

ORIGINATED BY JESSE LI DATE 2016-08-09	TITLE gigabit MagJack® (8 cores, Tab Up) 0826-1A1T-43-F PATENTED	PART NO. / DRAWING NO. 08261A1T43-F	STANDARD DIM. [] METRIC DIM.	
			TOL. IN INCH AS REF.	
			.X	UNIT : INCH [mm]
DRAWN BY JOLLY LUO DATE 2016-08-09		FILE NAME 08261A1T43-F_D.DWG	.XX	SCALE : N/A
			.XXX	±0.010 SIZE : A4



THE INFORMATION CONTAINED HEREIN IS CONSIDERED "PROPRIETARY" TO BEL FUSE INC. AND SHALL NOT BE COPIED, REPRODUCED OR DISCLOSED WITHOUT THE WRITTEN APPROVAL OF BEL FUSE INC.

RoHS



RECOMMENDED PCB FOOTPRINT
COMPONENT SIDE VIEW

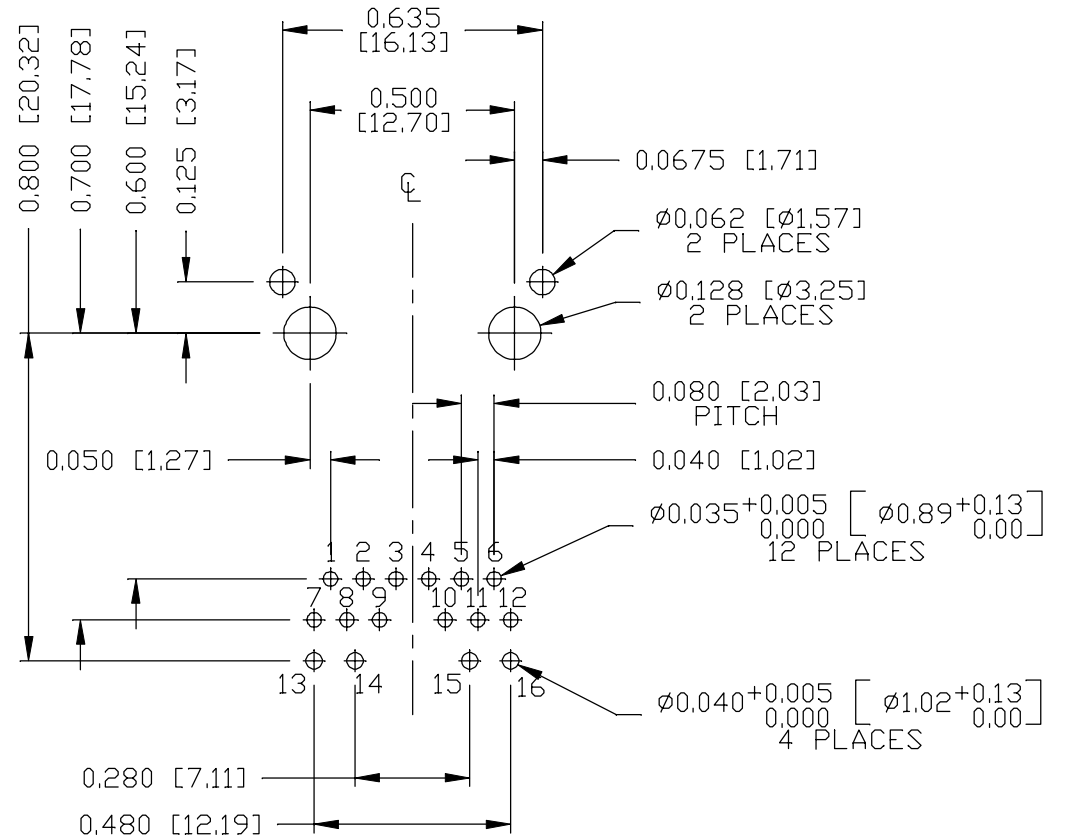
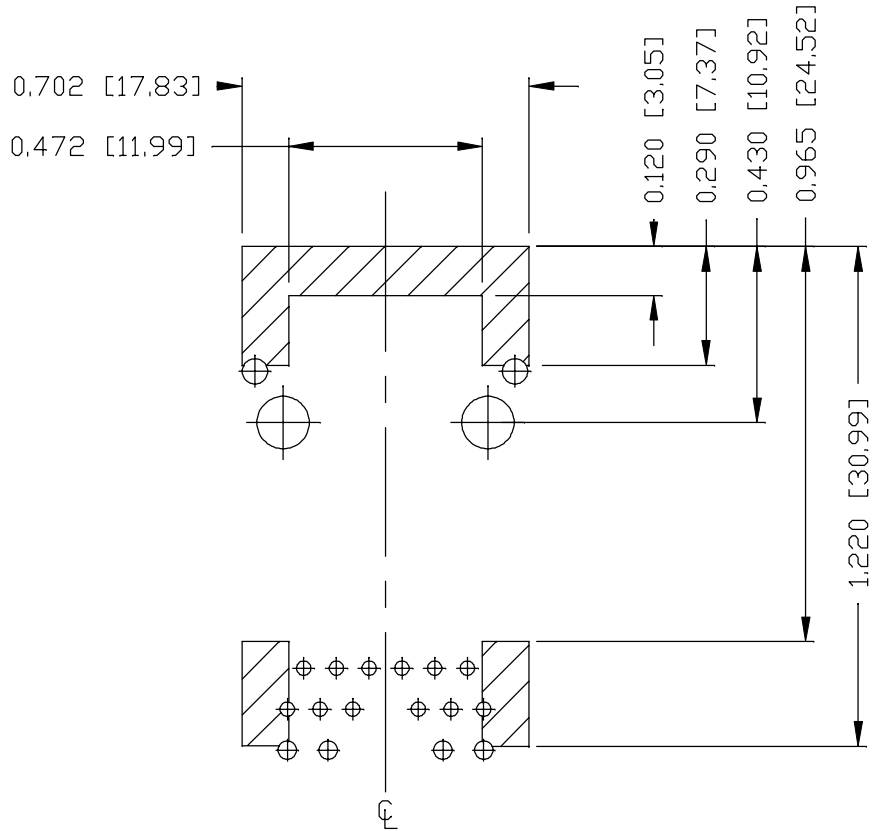

NOTES

THE SHADED AREA ON THE CUSTOMER BOARD ARE RECOMMENDED TO BE CLEAR OFF ANY VIA HOLE OR COMPONENT PAD.

REV. : D PAGE : 4

ORIGINATED BY
JESSE LI
DATE 2016-08-09
DRAWN BY
JOLLY LUO
DATE 2016-08-09

TITLE
gigabit MagJack®
(8 cores, Tab Up)
0826-1A1T-43-F
PATENTED

PART NO. / DRAWING NO.
08261A1T43-F
FILE NAME
08261A1T43-F_D.DWG

STANDARD DIM. TOL. IN INCH	[] METRIC DIM. AS REF.
.X	UNIT : INCH [mm]
.XX	SCALE : N/A
.XXX	SIZE : A4



THE INFORMATION CONTAINED HEREIN IS CONSIDERED "PROPRIETARY" TO BEL FUSE INC. AND SHALL NOT BE COPIED, REPRODUCED OR DISCLOSED WITHOUT THE WRITTEN APPROVAL OF BEL FUSE INC.

RoHS



SUGGESTED PANEL OPENING

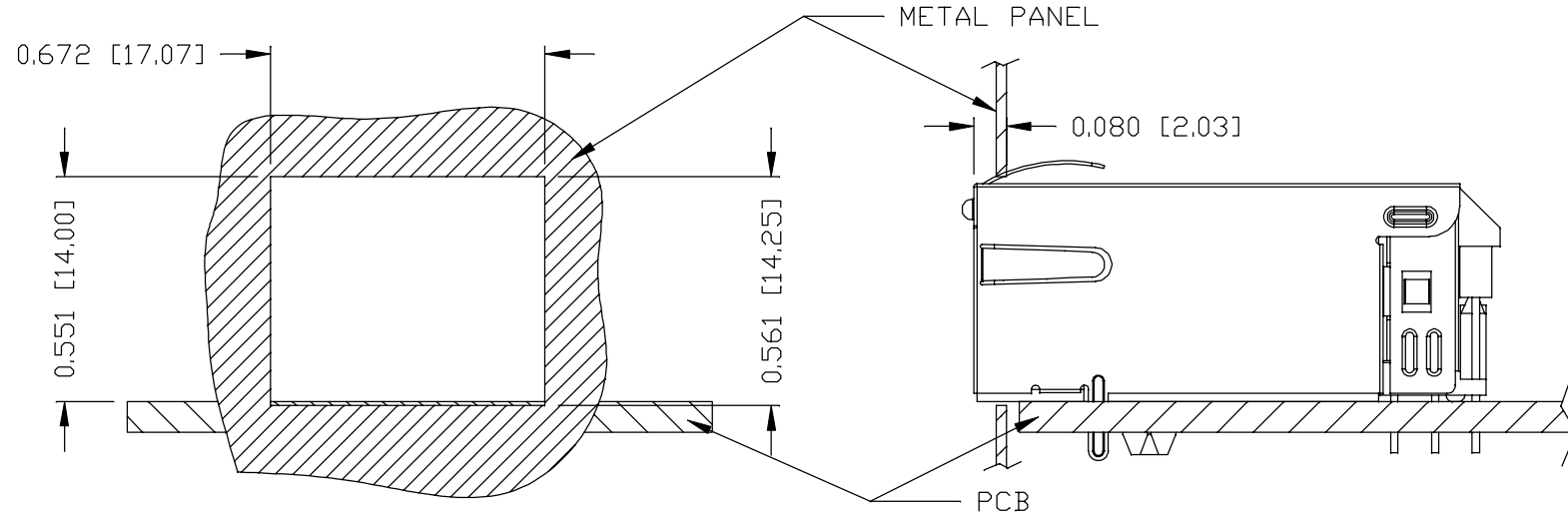

NOTE:

THE DISTANCE OF PANEL INSIDE SURFACE RELATIVE TO FRONT SURFACE OF PART IS ONLY A SUGGESTION. IN CASE THIS DISTANCE IS DIFFERENT, THE REQUIRED PANEL OPENING DIMENSIONS CHANGE ACCORDINGLY.

PACKING INFORMATION

PACKING TRAY : 0200-9999-F6 (TOP)
0200-9999-F7 (BOTTOM)

PACKING QUANTITY : 40 PCS FINISHED GOODS PER TRAY
10 TRAYS (400 PCS FINISHED GOODS) PER CARTON BOX

NOTE : CARDBOARDS ARE PLACED BETWEEN LAYERS OF PACKING TRAY INSIDE CARTON BOX
(INCLUDE THE UPPERMOST AND LOWERMOST TRAY)

REV. :	D	PAGE :	5
--------	---	--------	---

ORIGINATED BY JESSE LI DATE 2016-08-09	TITLE glgabit MagJack® (8 cores, Tab Up) 0826-1A1T-43-F PATENTED	PART NO. / DRAWING NO. 08261A1T43-F	STANDARD DIM. TOL. IN INCH	[] METRIC DIM. AS REF.
		FILE NAME 08261A1T43-F_D.DWG	.X	UNIT : INCH [mm]
			.XX	SCALE : N/A
DRAWN BY JOLLY LUO DATE 2016-08-09			.XXX	±0.004
			SIZE : A4	



Looking for pricing, stock, or lifecycle information?

Click below to explore more details on WIN SOURCE:

 [View 0826-1A1T-43-F on WIN SOURCE](#)

 [Bel Fuse Inc. Information](#)

Optimize Your Supply Chain with WIN SOURCE Solutions

-  Global Sourcing Solution
-  Obsolete Management
-  Cost Control Management
-  Shortage Management
-  Alternative Solution
-  Excess Inventory Management