



**THE DATASHEET OF
DS99R124QSQ/NOPB**



DS99R124Q 5 - 43 MHz 18-bit Color FPD-Link II to FPD-Link Converter

Check for Samples: [DS99R124Q](#)

FEATURES

- **5 – 43 MHz Support (140 Mbps to 1.2 Gbps Serial Link)**
- **4-Channel (3 data + 1 Clock) FPD-Link LVDS Outputs**
- **3 Low-Speed Over-Sampled LVCMOS Outputs**
- **AC Coupled STP Interconnect up to 10 Meters in Length**
- **Integrated Input Termination**
- **@ Speed Link BIST Mode and Reporting Pin**
- **Optional I2C Compatible Serial Control Bus**
- **RGB666 + VS, HS, DE Converted from 1 Pair**
- **Power Down Mode Minimizes Power Dissipation**
- **FAST Random Data Lock; no Reference Clock Required**
- **Adjustable Input Receive Equalization**
- **LOCK (Real Time Link Status) Reporting Pin**
- **Low EMI FPD-Link Output**
- **SSCG Option for Lower EMI**
- **1.8V or 3.3V Compatible I/O Interface**
- **Automotive Grade Product: AEC-Q100 Grade 2 Qualified**
- **>8 kV HBM and ISO 10605 ESD Rating**

APPLICATIONS

- **Automotive Display for Navigation**
- **Automotive Display for Entertainment**

DESCRIPTION

The DS99R124Q converts FPD-Link II to FPD-Link. It translates a high-speed serialized interface with an embedded clock over a single pair (FPD-Link II) to three LVDS data/control streams and one LVDS clock pair (FPD-Link). This serial bus scheme greatly eases system design by eliminating skew problems between clock and data, reduces the number of connector pins, reduces the interconnect size, weight, and cost, and overall eases PCB layout. In addition, internal DC balanced decoding is used to support AC-coupled interconnects.

The DS99R124Q converter recovers the data (RGB) and control signals and extracts the clock from a serial stream (FPD-Link II). It is able to lock to the incoming data stream without the use of a training sequence or special SYNC patterns and does not require a reference clock. A link status (LOCK) output signal is provided.

Adjustable input equalization of the serial input stream provides compensation for transmission medium losses of the cable and reduces the medium-induced deterministic jitter. EMI is minimized by the use of low voltage differential signaling, output state select feature, and additional output spread spectrum generation.

With fewer wires to the physical interface of the display, FPD-Link output with LVDS technology is ideal for high speed, low power and low EMI data transfer.

The DS99R124Q is offered in a 48-pin WQFN package and is specified over the automotive AEC-Q100 Grade 2 temperature range of -40°C to +105°C.



Please be aware that an important notice concerning availability, standard warranty, and use in critical applications of Texas Instruments semiconductor products and disclaimers thereto appears at the end of this data sheet.

All trademarks are the property of their respective owners.

Applications Diagram

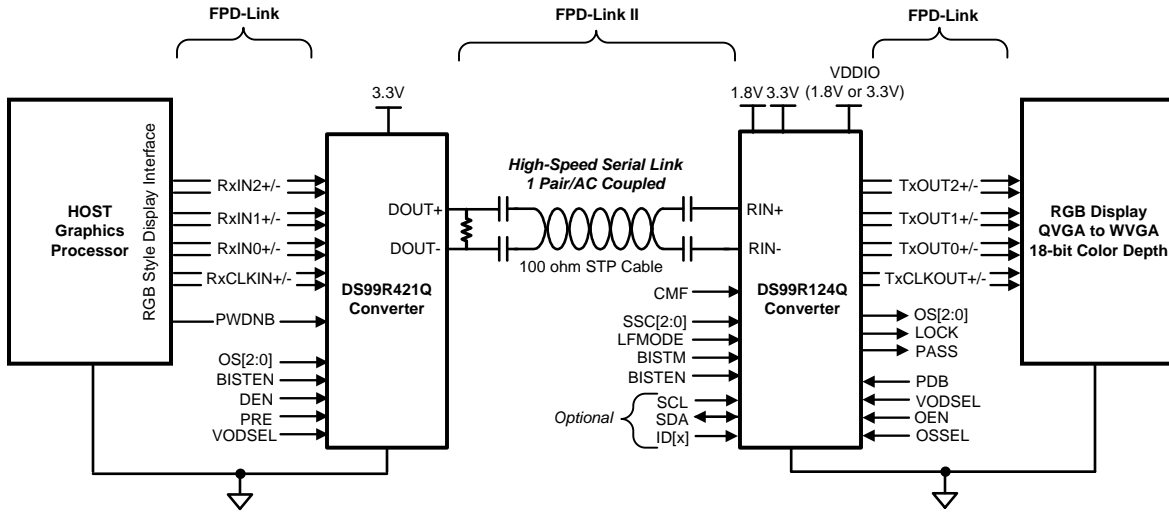

Figure 1.

DS99R124Q Pin Diagram

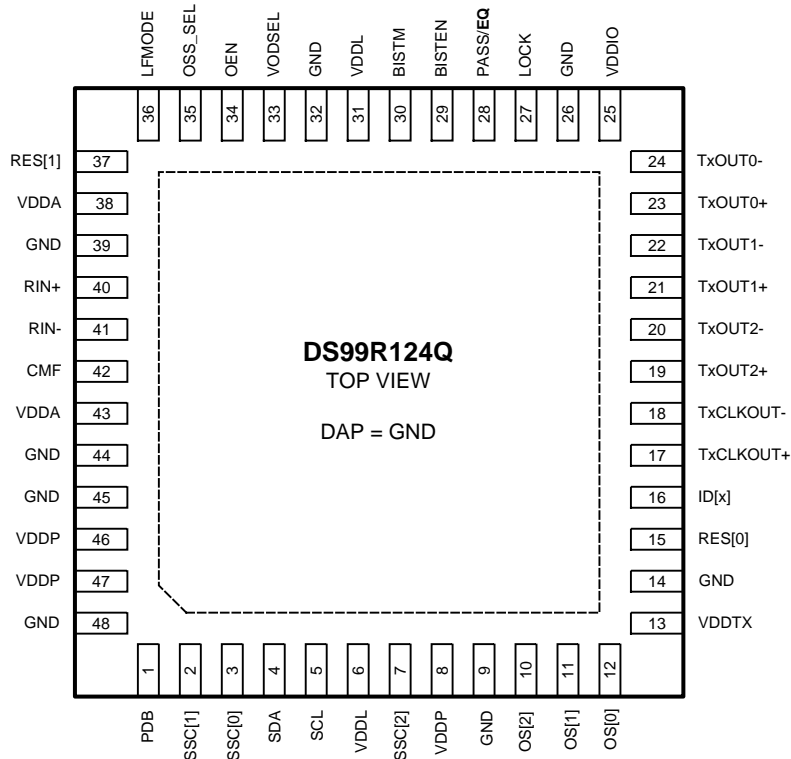

Figure 2. FPD-Link II to FPD-Link Converter - DS99R124Q
48 Pin WQFN Package
See Package Number RHS0048A

PIN DESCRIPTIONS

Pin Name	Pin #	I/O, Type	Description
FPD-Link II Input Interface			
RIN+	40	I, LVDS	True input The input must be AC coupled with a 100 nF capacitor. Internal termination.
RIN-	41	I, LVDS	Inverting input The input must be AC coupled with a 100 nF capacitor. Internal termination.
CMF	42	I, Analog	Common-Mode Filter VCM center-tap is a virtual ground which maybe ac-coupled to ground to increase receiver common mode noise immunity. Recommended value is 4.7 μ F or higher.
FPD-Link Output Interface			
TxOUT[2:0]+	19, 21, 23	O, LVDS	True LVDS Data Output This pair should have a 100 Ω termination for standard LVDS levels.
TxOUT[2:0]-	20, 22, 24	O, LVDS	Inverting LVDS Data Output This pair should have a 100 Ω termination for standard LVDS levels.
TxCLKOUT+	17	O, LVDS	True LVDS Clock Output This pair should have a 100 Ω termination for standard LVDS levels.
TxCLKOUT-	18	O, LVDS	Inverting LVDS Clock Output This pair should have a 100 Ω termination for standard LVDS levels.
LVC MOS Outputs			
OS[2:0]	10, 11, 12	O, LVCMOS	Over-Sampled Low Frequency Outputs These bits map to the DS99R421's OS[2:0] over-sampled low-frequency inputs. Signals must be slower the TxCLK/5. On the DS90UR241 these map to the DIN[23:21] inputs. OS0 = DIN21, OS1 = DIN22, OS2 = DIN23.
LOCK	27	O, LVCMOS	LOCK Status Output LOCK = 1, PLL is locked, outputs are active. LOCK = 0, PLL is unlocked, output states determined by OSS_SEL. Maybe used as a Link Status or to flag when the Video Data is active (ON/OFF).
Control and Configuration			
PDB	1	I, LVCMOS w/ pull-down	Power Down Mode Input PDB = 1, Device is enabled (normal operation) PDB = 0, Device is in power-down, the output are controlled by the settings. Control registers are RESET .
VODSEL	33	I, LVCMOS w/ pull-down	Differential Driver Output Voltage Select VODSEL = 1, LVDS VOD is \pm 400 mV, 800 mVp-p (typ) — Long Cable / De-E Applications VODSEL = 0, LVDS VOD is \pm 250 mV, 500 mVp-p (typ) See Table 2
OEN	34	I, LVCMOS w/ pull-down	Output Enable Input OEN = 1, FPD-Link outputs are enabled (active). OEN = 0, FPD-Link outputs are TRI-STATE.
OSS_SEL	35	I, LVCMOS w/ pull-down	Output Sleep State Select Input See Table 1
LFMODE	36	I, LVCMOS w/ pull-down	Low Frequency Mode — Pin or Register Control LF_MODE = 1, low frequency mode (TxCLKOUT = 5-20 MHz) LF_MODE = 0, high frequency mode (TxCLKOUT = 20-43 MHz)
SSC[2:0]	7, 2, 3	I, LVCMOS w/ pull-down	Spread Spectrum Clock Generation (SSCG) Range Select See Table 3 and Table 4
RES[1:0]	37, 15	I, LVCMOS w/ pull-down	Reserved Tie Low
Control and Configuration — STRAP PIN			
For a High State, use a 10 k Ω pull up to VDDIO; for a Low State, the IO includes an internal pull down. The STRAP pin is read upon power-up and set device configuration. Pin number listed along with shared LVCMOS Output name in square bracket.			
EQ	28 [PASS]	STRAP I, LVCMOS w/ pull-down	EQ Gain Control of FPD-Link II Input EQ = 1, EQ gain is enabled (~13 dB) EQ = 0, EQ gain is disabled (~1.625 dB)
Optional BIST Mode			
BISTEN	29	I, LVCMOS w/ pull-down	BIST Enable Input – Optional BISTEN = 1, BIST Mode is enabled. BISTEN = 0, normal mode.

PIN DESCRIPTIONS (continued)

Pin Name	Pin #	I/O, Type	Description
BISTM	30	I, LVCMOS w/ pull-down	BIST Mode Input – Optional BISTM = 1, selects Payload Error Mode BISTM = 0, selects Pass / Fail Result-Only Mode
PASS	28	O, LVCMOS	PASS Output (BIST Mode) – Optional PASS = 1, no errors detected PASS = 0, errors detected Leave open if unused. Route to a test point (pad) recommended.
Optional Serial Bus Control Interface			
SCL	5	I, LVCMOS	Serial Control Bus Clock Input - Optional SCL requires an external pull-up resistor to V _{DDIO} .
SDA	4	I/O, LVCMOS Open Drain	Serial Control Bus Data Input / Output - Optional SDA requires an external pull-up resistor to V _{DDIO} .
ID[x]	16	I, Analog	Serial Control Bus Device ID Address Select — Optional Resistor to Ground and 10 kΩ pull-up to 1.8V rail. See Table 5.
Power and Ground			
VDDL	6, 31	Power	Logic Power, 1.8 V ±5%
VDDA	38, 43	Power	Analog Power, 1.8 V ±5%
VDDP	8, 46, 47	Power	SSC Generator Power, 1.8 V ±5%
VDDTX	13	Power	FPD-Link Power, 3.3 V ±10%
VDDIO	25	Power	LVCMOS I/O Power, 1.8 V ±5% OR 3.3 V ±10%
GND	9, 14, 26, 32, 39, 44, 45, 48	Ground	Ground
DAP	DAP	Ground	DAP is the large metal contact at the bottom side, located at the center of the WQFN package. Connected to the ground plane (GND) with at least 9 vias.

Block Diagram

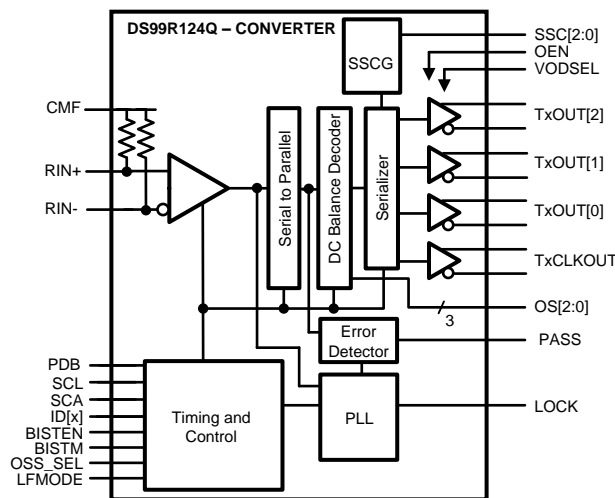

Figure 3. FPD-Link II to FPD-Link Convertor



These devices have limited built-in ESD protection. The leads should be shorted together or the device placed in conductive foam during storage or handling to prevent electrostatic damage to the MOS gates.

Absolute Maximum Ratings⁽¹⁾⁽²⁾

Supply Voltage – V_{DDn} (1.8V)		-0.3V to +2.5V
Supply Voltage – V_{DDTX} (3.3V)		-0.3V to +4.0V
Supply Voltage – V_{DDIO}		-0.3V to +4.0V
LVC MOS I/O Voltage		-0.3V to +(VDDIO + 0.3V)
Receiver Input Voltage		-0.3V to (VDD + 0.3V)
LVDS Output Voltage		-0.3V to (VDDTX + 0.3V)
Junction Temperature		+150°C
Storage Temperature		-65°C to +150°C
Lead Temperature (Soldering, 4s)		+260°C
48L RHS Package		
Maximum Power Dissipation Capacity at 25°C	Derate above 25°C	$1/\theta_{JA}$ °C/W
	θ_{JA}	27.7 °C/W
	θ_{JC}	3.0 °C/W
ESD Rating (IEC, powered-up only), $R_D = 330\Omega$, $C_S = 150\text{pF}$	Air Discharge (R_{IN+} , R_{IN-})	$\geq \pm 30$ kV
	Contact Discharge (R_{IN+} , R_{IN-})	$\geq \pm 6$ kV
ESD Rating (ISO10605), $R_D = 330\Omega$, $C_S = 150$ & 330pF	Air Discharge (R_{IN+} , R_{IN-})	$\geq \pm 15$ kV
	Contact Discharge (R_{IN+} , R_{IN-})	$\geq \pm 8$ kV
ESD Rating (ISO10605), $R_D = 2\text{k}\Omega$, $C_S = 150$ & 330pF	Air Discharge (R_{IN+} , R_{IN-})	$\geq \pm 15$ kV
	Contact Discharge (R_{IN+} , R_{IN-})	$\geq \pm 8$ kV
ESD Rating (HBM)		$\geq \pm 8$ kV
ESD Rating (CDM)		$\geq \pm 1.25$ kV
ESD Rating (MM)		$\geq \pm 250$ V

- (1) "Absolute Maximum Ratings" indicate limits beyond which damage to the device may occur, including inoperability and degradation of device reliability and/or performance. Functional operation of the device and/or non-degradation at the Absolute Maximum Ratings or other conditions beyond those indicated in the Recommended Operating Conditions is not implied. The Recommended Operating Conditions indicate conditions at which the device is functional and the device should not be operated beyond such conditions.
- (2) If Military/Aerospace specified devices are required, please contact the Texas Instruments Sales Office/ Distributors for availability and specifications.

Recommended Operating Conditions

	Min	Nom	Max	Units
Supply Voltage (V_{DDn})	1.71	1.8	1.89	V
LVC MOS Supply Voltage (V_{DDIO})	1.71	1.8	1.89	V
LVC MOS Supply Voltage (V_{DDIO})	3.0	3.3	3.6	V
Operating Free Air Temperature (T_A)	-40	+25	+105	°C
TxCLK Clock Frequency	5		43	MHz
Supply Noise ⁽¹⁾			100	mV _{P-P}

- (1) Supply noise testing was done with minimum capacitors on the PCB. A sinusoidal signal is AC coupled to the V_{DDn} (1.8V) supply with amplitude = 100 mVp-p measured at the device V_{DDn} pins. Bit error rate testing of input to the Ser and output of the Des with 10 meter cable shows no error when the noise frequency on the Ser is less than 750 kHz. The Des on the other hand shows no error when the noise frequency is less than 400 kHz.

DC Electrical Characteristics

Over recommended operating supply and temperature ranges unless otherwise specified. ⁽¹⁾ ⁽²⁾ ⁽³⁾

Symbol	Parameter	Conditions	Pin/Freq.	Min	Typ	Max	Units
FPD-Link LVDS Output							
V _{OD}	Differential Output Voltage	R _L = 100Ω	VODSEL = L	100	250	400	mV
			VODSEL = H	200	400	600	mV
V _{ODp-p}	Differential Output Voltage A-B		VODSEL = L		500		mVp-p
			VODSEL = H		800		mVp-p
ΔV _{OD}	Output Voltage Unbalance				1	50	mV
V _{OS}	Offset Voltage		VODSEL = L	1.0	1.2	1.5	V
			VODSEL = H		1.2		V
ΔV _{OS}	Offset Voltage Unbalance				1	50	mV
I _{OS}	Output Short Circuit Current	V _{out} = GND			-5		mA
I _{OZ}	Output TRI-STATE Current	OEN = GND, V _{out} = V _{DDTX} , or GND		-10		+10	μA
3.3 V I/O LVCMOS DC SPECIFICATIONS – V_{DDIO} = 3.0 to 3.6V							
V _{IH}	High Level Input Voltage		PDB, VODSEL, OEN, OSS_SEL, LFMODE, SSC[2:0], BISTEN, BISTM	2.2		V _{DDIO}	V
V _{IL}	Low Level Input Voltage			GND		0.8	V
I _{IN}	Input Current	V _{IN} = 0V or V _{DDIO}		-15	±1	+15	μA
V _{OH}	High Level Output Voltage	I _{OH} = -0.5 mA		V _{DDIO} - 0.2	V _{DDIO}		V
V _{OL}	Low Level Output Voltage	I _{OL} = +0.5 mA	LOCK, PASS, OS[2:0]		GND	0.2	V
I _{OS}	Output Short Circuit Current	V _{OUT} = 0V			-10		mA
I _{OZ}	TRI-STATE Output Current	PDB = 0V, OSS_SEL = 0V, V _{OUT} = 0V or V _{DDIO}		-10		+10	μA
1.8 V I/O LVCMOS DC SPECIFICATIONS – V_{DDIO} = 1.71 to 1.89V							
V _{IH}	High Level Input Voltage		PDB, VODSEL, OEN, OSS_SEL, LFMODE, SSC[2:0], BISTEN, BISTM	0.7 V _{DDIO}		V _{DDIO}	V
V _{IL}	Low Level Input Voltage			GND		0.35* V _{DDIO}	V
I _{IN}	Input Current	V _{IN} = 0V or V _{DDIO}		-10	±1	+10	μA

- (1) The Electrical Characteristics tables list ensured specifications under the listed Recommended Operating Conditions except as otherwise modified or specified by the Electrical Characteristics Conditions and/or Notes. Typical specifications are estimations only and are not ensured.
- (2) Typical values represent most likely parametric norms at V_{DDn} = 1.8V, V_{DDTX} = 3.3V, V_{DDIO} = 1.8V or 3.3V, T_a = +25 °C, and at the Recommended Operation Conditions at the time of product characterization and are not ensured.
- (3) Current into device pins is defined as positive. Current out of a device pin is defined as negative. Voltages are referenced to ground except V_{OD}, ΔV_{OD}, V_{TH} and V_{TL} which are differential voltages.

DC Electrical Characteristics (continued)

 Over recommended operating supply and temperature ranges unless otherwise specified.⁽¹⁾⁽²⁾⁽³⁾

Symbol	Parameter	Conditions	Pin/Freq.	Min	Typ	Max	Units
V _{OH}	High Level Output Voltage	I _{OH} = -0.1 mA	LOCK, PASS, OS[2:0]	V _{DDIO} - 0.2	V _{DDIO}		V
V _{OL}	Low Level Output Voltage	I _{OL} = +0.1 mA		GND		0.2	V
I _{OS}	Output Short Circuit Current	V _{OUT} = 0V				-3	mA
I _{OZ}	TRI-STATE Output Current	V _{OUT} = 0V or V _{DDIO}			-15		+15

FPD-Link II LVDS RECEIVER DC SPECIFICATIONS

V _{TH}	Differential Input Threshold High Voltage	V _{CM} = +1.2V (Internal V _{BIAS})	RIN+, RIN-			+50	mV	
V _{TL}	Differential Input Threshold Low Voltage					-50		mV
V _{CM}	Common Mode Voltage, Internal V _{BIAS}					1.2		V
R _T	Input Termination				75	80	92	Ω

SUPPLY CURRENT

I _{DD1}	Supply Current (includes load current) 43 MHz Clock	Checker Board Pattern, VODSEL = H, SSCG = On Figure 4	V _{DDn} = 1.89V	All V _{DD(1,8)} pins		70	80	mA
I _{DDTX1}			V _{DDTX} = 3.6V	V _{DDTX}		30	40	mA
I _{DDIO1}			V _{DDIO} = 1.89V	V _{DDIO}		0.35	1	mA
			V _{DDIO} = 3.6V			1	1.5	mA
I _{DDZ}	Supply Current Power Down	PDB = 0V, All other LVCMOS Inputs = 0V	V _{DD} = 1.89V	All V _{DD(1,8)} pins		0.15	4	mA
I _{DDTXZ}			V _{DDTX} = 3.6V	V _{DDTX}		0.01	0.05	mA
I _{DDIOZ}			V _{DDIO} = 1.89V	V _{DDIO}		0.1	0.4	mA
			V _{DDIO} = 3.6V			0.4	0.8	mA

Switching Characteristics

 Over recommended operating supply and temperature ranges unless otherwise specified.⁽¹⁾⁽²⁾

Symbol	Parameter	Conditions	Pin/Freq.	Min	Typ	Max	Units
FPD-Link II							
t _{DDL}	Lock Time ⁽³⁾	SSCG = Off	5 MHz		6		ms
		SSCG = On	5 MHz		14		ms
		SSCG = Off	43 MHz		5		ms
		SSCG = On	43 MHz		8		ms
t _{DJIT}	Input Jitter Tolerance	EQ = Off Jitter Frequency > 10 MHz Figure 14			>0.45		UI
FPD-Link Output							

- (1) The Electrical Characteristics tables list ensured specifications under the listed Recommended Operating Conditions except as otherwise modified or specified by the Electrical Characteristics Conditions and/or Notes. Typical specifications are estimations only and are not ensured.
- (2) Typical values represent most likely parametric norms at V_{DDn} = 1.8V, V_{DDTX} = 3.3V, V_{DDIO} = 1.8V or 3.3V, T_a = +25 °C, and at the Recommended Operation Conditions at the time of product characterization and are not ensured.
- (3) t_{DDL} is the time required by the deserializer to obtain lock when exiting power-down state with an active PCLK.

Switching Characteristics (continued)

Over recommended operating supply and temperature ranges unless otherwise specified.⁽¹⁾⁽²⁾

Symbol	Parameter	Conditions	Pin/Freq.	Min	Typ	Max	Units
t _{TLHT}	Low to High Transition Time	R _L = 100Ω	TxCLKOUT±, TxOUT[2:0]±		0.3	0.6	ns
t _{THLT}	High to Low Transition Time				0.3	0.6	ns
t _{DCCJ}	Cycle-to-Cycle Output Jitter ⁽⁴⁾⁽⁵⁾	TxCLKOUT = 5 MHz	TxCLKOUT±		900	2100	ps
		TxCLKOUT = 43 MHz			75	125	ps
t _{TTP1}	Transmitter Pulse Position for bit 1		TxOUT[2:0]±		0		UI
t _{TTP0}	Transmitter Pulse Position for bit 0				1		UI
t _{TTP6}	Transmitter Pulse Position for bit 6				2		UI
t _{TTP5}	Transmitter Pulse Position for bit 5				3		UI
t _{TTP4}	Transmitter Pulse Position for bit 4				4		UI
t _{TTP3}	Transmitter Pulse Position for bit 3				5		UI
t _{TTP2}	Transmitter Pulse Position for bit 2				6		UI
t _{TPDD}	Power Down Delay active to OFF Figure 6	TxCLKOUT = 43 MHz			6	10	ns
t _{TXZR}	Enable Delay OFF to active Figure 7	TxCLKOUT = 43 MHz			40	55	ns
LVC MOS Outputs							
t _{CLH}	Low to High Transition Time	C _L = 8 pF Figure 5	LOCK, PASS, OS[2:0]		10	15	ns
t _{CHL}	High to Low Transition Time				10	15	ns
t _{PASS}	BIST PASS Valid Time, BISTEN = 1, Figure 12	TxCLKOUT = 5 MHz	PASS		560	570	ns
		TxCLKOUT = 43 MHz			70	75	ns
SSCG Mode							
f _{DEV}	Spread Spectrum Clocking Deviation Frequency	See ⁽⁶⁾	TxCLKOUT = 5 to 43 MHz, SSC[3:0] = ON	±0.5		±2	%
f _{MOD}	Spread Spectrum Clocking Modulation Frequency	See ⁽⁶⁾	TxCLKOUT = 5 to 43 MHz, SSC[3:0] = ON	8		100	kHz

(4) t_{DCCJ} is the maximum amount of jitter between adjacent clock cycles.

(5) Specification is ensured by characterization and is not tested in production.

(6) Specification is ensured by design and is not tested in production.

Recommended Timing for the Serial Control Bus

Over recommended operating supply and temperature ranges unless otherwise specified.

Symbol	Parameter	Conditions	Min	Typ	Max	Units
f _{SCL}	SCL Clock Frequency	Standard Mode	0		100	kHz
		Fast Mode	0		400	kHz
t _{LOW}	SCL Low Period	Standard Mode	4.7			us
		Fast Mode	1.3			us
t _{HIGH}	SCL High Period	Standard Mode	4.0			us
		Fast Mode	0.6			us
t _{HD;STA}	Hold time for a start or a repeated start condition, Figure 13	Standard Mode	4.0			us
		Fast Mode	0.6			us

Recommended Timing for the Serial Control Bus (continued)

Over recommended operating supply and temperature ranges unless otherwise specified.

Symbol	Parameter	Conditions	Min	Typ	Max	Units
t _{SU:STA}	Set Up time for a start or a repeated start condition, Figure 13	Standard Mode	4.7			us
		Fast Mode	0.6			us
t _{HD:DAT}	Data Hold Time, Figure 13	Standard Mode	0		3.45	us
		Fast Mode	0		0.9	us
t _{SU:DAT}	Data Set Up Time, Figure 13	Standard Mode	250			ns
		Fast Mode	100			ns
t _{SU:STO}	Set Up Time for STOP Condition, Figure 13	Standard Mode	4.0			us
		Fast Mode	0.6			us
t _{BUF}	Bus Free Time Between STOP and START, Figure 13	Standard Mode	4.7			us
		Fast Mode	1.3			us
t _r	SCL & SDA Rise Time, Figure 13	Standard Mode			1000	ns
		Fast Mode			300	ns
t _f	SCL & SDA Fall Time, Figure 13	Standard Mode			300	ns
		Fast mode			300	ns

DC and AC Serial Control Bus Characteristics

Over recommended operating supply and temperature ranges unless otherwise specified.

Symbol	Parameter	Conditions	Min	Typ	Max	Units
V _{IH}	Input High Level	SDA and SCL	0.7* V _{DDIO}		V _{DDIO}	V
V _{IL}	Input Low Level Voltage	SDA and SCL	GND		0.3* V _{DDIO}	V
V _{HY}	Input Hysteresis			>50		mV
V _{OL}		SDA, I _{OL} = +0.5 mA	0		0.36	V
I _{in}		SDA or SCL, V _{in} = V _{DDIO} or GND	-10		+10	μA
t _R	SDA Rise Time – READ	SDA, RPU = X, C _b ≤ 400pF			850	ns
t _F	SDA Fall Time – READ				120	ns
t _{SU:DAT}	Set Up Time — READ		500			ns
t _{HD:DAT}	Hold Up Time — READ		580			ns
t _{SP}	Input Filter			50		ns
C _{in}	Input Capacitance	SDA or SCL		<5		pF

AC Timing Diagrams and Test Circuits

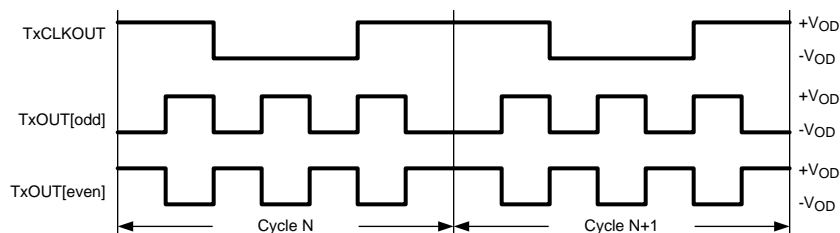

Figure 4. Checkerboard Data Pattern

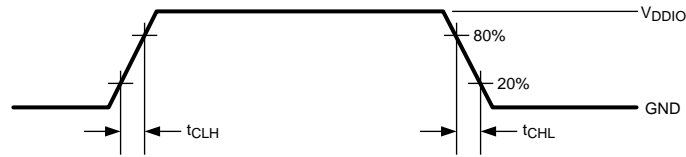

Figure 5. LVC MOS Transition Times

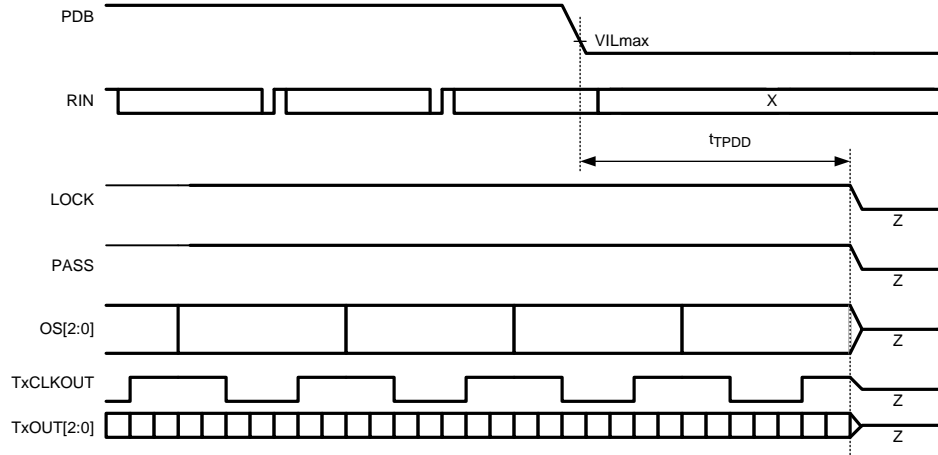

Figure 6. FPD-Link & LVC MOS Powerdown Delay

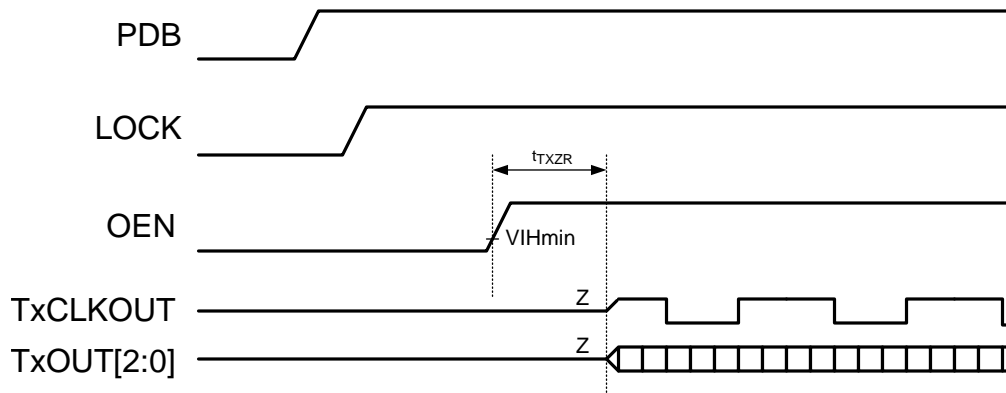

Figure 7. FPD-Link Outputs Enable Delay

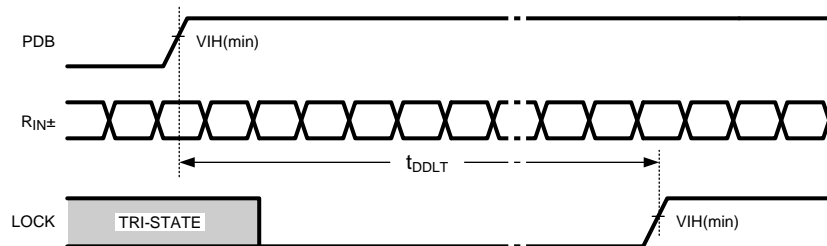

Figure 8. Deserializer PLL Lock Times

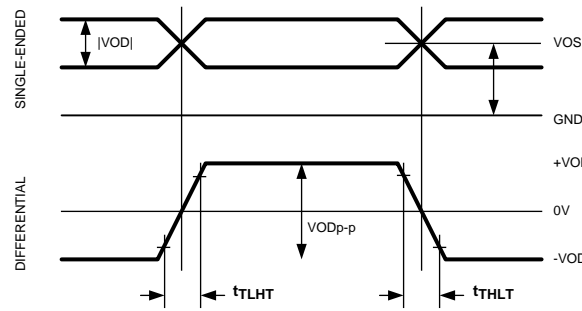

Figure 9. FPD-Link (LVDS) Single-ended and Differential Waveforms

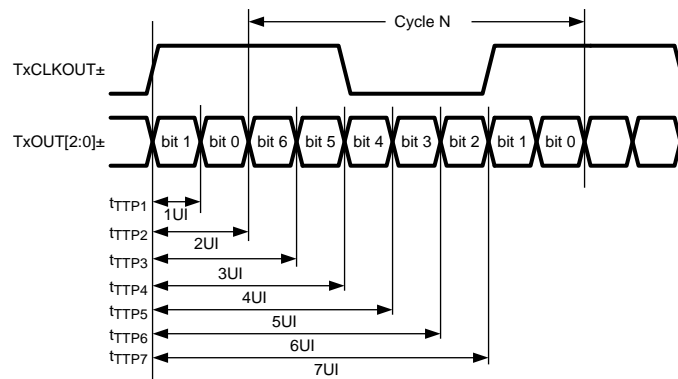

Figure 10. FPD-Link Transmitter Pulse Positions

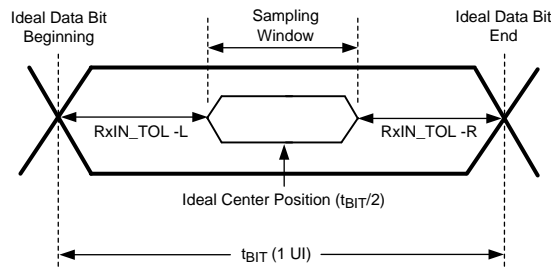

Figure 11. Receiver Input Jitter Tolerance

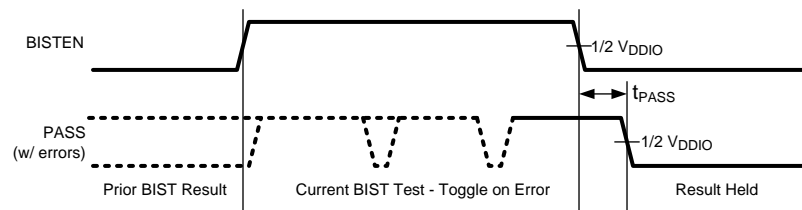

Figure 12. BIST PASS Waveform

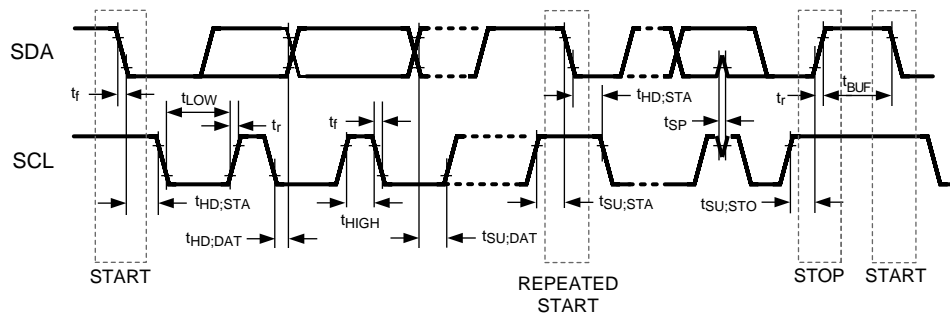

Figure 13. Serial Control Bus Timing Diagram

Typical Performance Characteristics

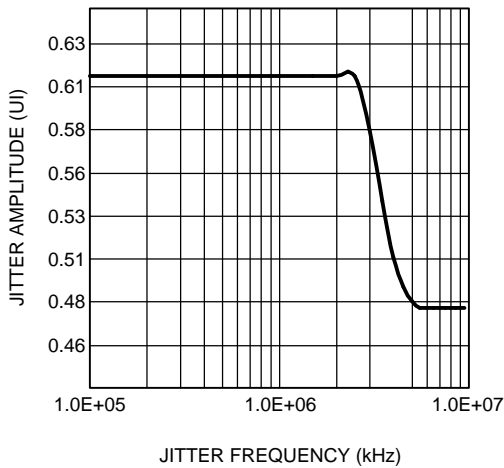

Figure 14. Typical Input Jitter Tolerance Curve at 43 MHz

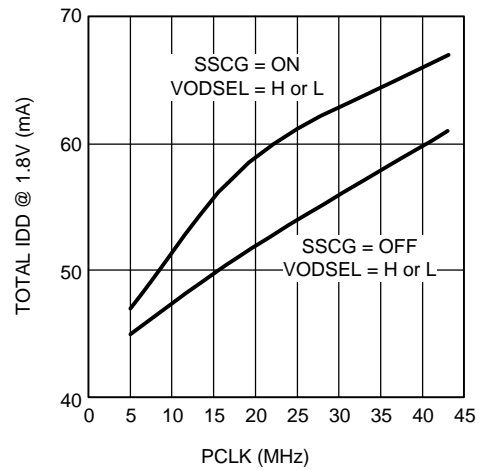

Figure 15. Typical Total IDD Current (1.8V Supply) as a Function of PCLK

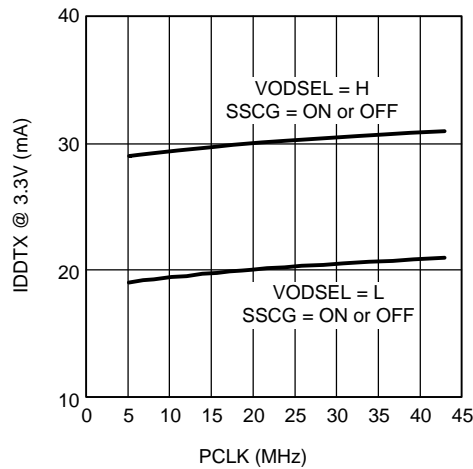

Figure 16. Typical IDDTX Current (3.3V Supply) as a Function of PCLK

FUNCTIONAL DESCRIPTION

The DS99R124Q receives 24-bits of data over a single serial FPD-Link II pair operating at 140Mbps to 1.2Gbps. The serial stream also contains an embedded clock, and the DC-balance information which enhances signal quality and supports AC coupling. The receiver copnverts the serial stream into a 4-channel (3 data and 1 clock) FPD-Link LVDS Interface. The device is intended to be used with the DS90UR241 or the DS99R421 FPD-Link II serializers.

The Des converts a single input serial data stream to a FPD-Link output bus, and also provides a signal check for the chipset Built In Self Test (BIST) mode. The device can be configured via external pins or through the optional serial control bus. The Des features enhance signal quality on the link by supporting the FPD-Link II data coding that provides randomization, scrambling, and DC balancing of the data. The Des includes multiple features to reduce EMI associated with display data transmission. This includes the randomization and scrambling of the data, FPD-Link LVDS Output interface, and also the output spread spectrum clock generation (SSCG) support. The Des' power saving features include a power down mode, and optional LVCMOS (1.8 V) interface compatibility.

The Des can attain lock to a data stream without the use of a separate reference clock source, which greatly simplifies system complexity and overall cost. The Des also synchronizes to the Ser regardless of the data pattern, delivering true automatic “plug and lock” performance. It can lock to the incoming serial stream without the need of special training patterns or sync characters. The Des recovers the clock and data by extracting the embedded clock information, validating and then deserializing the incoming data stream.

The DS99R421Q / DS99R124Q chipset supports 18-bit color depth, HS, VS and DE video control signals and up to three over-sampled low-speed (general purpose) data bits.

DATA TRANSFER

The DS99R124 will receive a pixel of data in the following format: C1 and C0 represent the embedded clock in the serial stream. C1 is always HIGH and C0 is always LOW. b[23:0] contain the scrambled data. DCB is the DC-Balanced control bit. DCB is used to minimize the short and long-term DC bias on the signal lines. This bit determines if the data is unmodified or inverted. DCA is used to validate data integrity in the embedded data stream. Both DCA and DCB coding schemes are generated by the Ser and decoded by the Des automatically. [Figure 17](#) illustrates the serial stream per PCLK cycle.

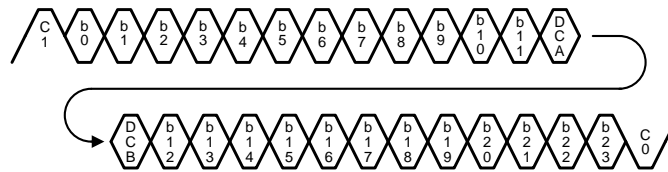

Figure 17. FPD-Link II Serial Stream (DS99R421/DS99R124)

The device supports clocks in the range of 5 MHz to 43 MHz. With every clock cycle 24 bits of payload are received along with the four overhead bits. Thus, the line rate is 1.2 Gbps maximum (140 Mbps minimum) with an effective data rate of 1.03 Gbps maximum. The link is extremely efficient at 86% (24/28).

The FPD-Link output will pass along the data to the Display in the format shown in [Figure 18](#).

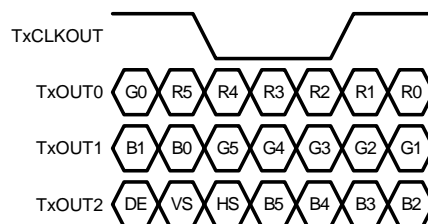

Figure 18. FPD-Link Output Format

FPD-LINK II INPUT

Common Mode Filter Pin (CMF) — Optional

The Des provides access to the center tap of the internal termination. A capacitor may be placed on this pin for additional common-mode filtering of the differential pair. This can be useful in high noise environments for additional noise rejection capability. A 4.7 μ F capacitor may be connected to this pin to Ground.

OUTPUT INTERFACES (LVCMOS & FPD-LINK)

OS[2:0] LVCMOS Outputs

Additional signals maybe received across the serial link per PCLK. The over-sampled bits are restricted to be low speed signals and should be less than 1/5 of the frequency of the PCLK. Signals should convey level information only, as pulse width distroction will occur by the over sampling technique and location of the sampling clock. The three over sampled bits are exactly mapped to DS99R421's; and to DS90UR421 bits are: OS0 = DIN21, OS1 = DIN22, and OS2 = DIN23.

CLOCK-DATA RECOVERY STATUS FLAG (LOCK) and OUTPUT STATE SELECT (OSS_SEL)

When PDB is driven HIGH, the CDR PLL begins locking to the serial input, LOCK is Low and the FPD-Link interface state is determined by the state of the OSS_SEL pin.

After the DS99R124Q completes its lock sequence to the input serial data, the LOCK output is driven HIGH, indicating valid data and clock recovered from the serial input is available on the FPD-Link outputs. The TxCLK output is held at its current state at the change from OSC_CLK (if this is enabled via OSC_SEL) to the recovered clock (or vice versa). Note that the FPD-Link outputs may be held in an inactive state (TRI-STATE) through the use of the Output Enable pin (OEN).

If there is a loss of clock from the input serial stream, LOCK is driven Low and the state of the outputs are based on the OSS_SEL setting (configuration pin or register).

Table 1. Output State Table

INPUTS			OUTPUTS	
PDB	OEN	OSS_SEL	LOCK	OTHER OUTPUTS
L	X	L	Z	TxCLKOUT is TRI-STATE TxOUT[2:0] are TRI-STATE OS[2:0] are TRI-STATE PASS is TRI-STATE
L	X	H	L	TxCLKOUT is TRI-STATE TxOUT[2:0] are TRI-STATE OS[2:0] are LOW PASS is TRI-STATE
H	L	L	L	TxCLKOUT is TRI-STATE TxOUT[2:0] are TRI-STATE OS[2:0] are LOW PASS is HIGH
H	L	H	L	TxCLKOUT is TRI-STATE TxOUT[2:0] are TRI-STATE OS[2:0] are LOW PASS is LOW
H	H	L	L	TxCLKOUT is TRI-STATE TxOUT[2:0] are TRI-STATE OS[2:0] are TRI-STATE PASS is HIGH
H	H	H	L	TxCLKOUT is TRI-STATE TxOUT[2:0] are LOW OS[2:0] are LOW PASS is LOW

Table 1. Output State Table (continued)

INPUTS			OUTPUTS	
PDB	OEN	OSS_SEL	LOCK	OTHER OUTPUTS
H	L	X	H	TxCLKOUT is TRI-STATE TxOUT[2:0] are TRI-STATE OS[2:0] are Active PASS is Active <i>(This setting allows the system to run BIST or use the OS[2:0] bits while the panel is off)</i>
H	H	X	H	TxCLKOUT is Active TxOUT[2:0] are Active OS[2:0] are Active PASS is Active <i>(Normal operating mode)</i>

LVC MOS 1.8V / 3.3V VDDIO Operation

The LVC MOS inputs and outputs can operate with 1.8 V or 3.3 V levels (V_{DDIO}) for target (Display) compatibility. The 1.8 V levels will offer a lower noise (EMI) and also a system power savings.

FPD-LINK OUTPUT**VODSEL**

The differential output voltage of the FPD-Link interface is controlled by the VODSEL input.

Table 2. VODSEL Configuration Table

VODSEL	Result
L	VOD is 250mV TYP (500mVp-p)
H	VOD is 400mV TYP (800mVp-p)

SSCG Generation — Optional

The Des provides an internally generated spread spectrum clock (SSCG) to modulate its outputs. Both clock and data outputs are modulated. This will aid to lower system EMI. Output SSCG deviations to $\pm 2.0\%$ (4% total) at up to 35kHz modulations nominally are available. See [Table 3](#) and [Table 4](#). This feature may be controlled by pins or by register. The LFMODE should be set appropriately if the SSCG is being used. Set LFMODE High if the clock frequency is between 5 MHz and 20 MHz, set LFMODE Low if the clock frequency is between 20 MHz and 43 MHz.

Table 3. SSCG Configuration (LFMODE = L) — Des Output

SSC[2:0] Inputs LFMODE = L (20 - 43 MHz)			Result	
SSC2	SSC1	SSC0	fdev (%)	fmod (kHz)
L	L	L	OFF	OFF
L	L	H	± 0.9	CLK/2168
L	H	L	± 1.2	
L	H	H	± 1.9	
H	L	L	± 2.3	
H	L	H	± 0.7	CLK/1300
H	H	L	± 1.3	
H	H	H	± 1.7	

Table 4. SSCG Configuration (LFMODE = H) — Des Output

SSC[2:0] Inputs LFMODE = H (5 - 20 MHz)			Result	
SSC2	SSC1	SSC0	fdev (%)	fmod (kHz)
L	L	L	OFF	OFF
L	L	H	±0.7	CLK/625
L	H	L	±1.3	
L	H	H	±1.8	
H	L	L	±2.2	
H	L	H	±0.7	CLK/385
H	H	L	±1.2	
H	H	H	±1.7	

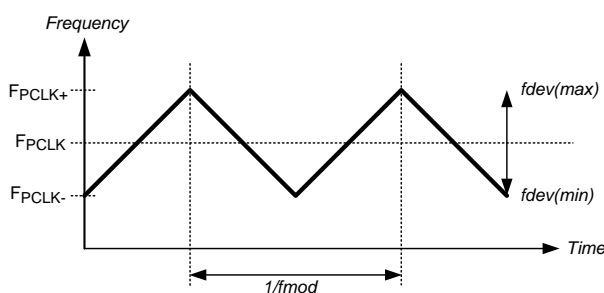

Figure 19. SSCG Waveform

POWER SAVING FEATURES

PowerDown Feature (PDB)

The Des has a PDB input pin to ENABLE or POWER DOWN the device. This pin can be controlled by the system to save power, disabling the Des when the display is not needed. An auto detect mode is also available. In this mode, the PDB pin is tied High and the Des will enter POWER DOWN when the serial stream stops. When the serial stream starts up again, the Des will lock to the input stream and assert the LOCK pin and output valid data. In POWER DOWN mode, the Data and PCLK output states are determined by the OSS_SEL status. Note – in POWER DOWN, the optional Serial Bus Control Registers are **RESET**.

Stop Stream SLEEP Feature

The Des will enter a low power SLEEP state when the input serial stream is stopped. A STOP condition is detected when the embedded clock bits are not present. When the serial stream starts again, the Des will then lock to the incoming signal and recover the data. Note – in STOP STREAM SLEEP, the optional Serial Bus Control Registers values are **RETAINED**.

Built In Self Test (BIST) — Optional

An optional At-Speed Built In Self Test (BIST) feature supports the testing of the high-speed serial link. This is useful in the prototype stage, equipment production, in-system test and also for system diagnostics. In the BIST mode only an input clock is required along with control to the Ser and Des BISTEN input pins. The Ser outputs a test pattern (PRBS7) and drives the link at speed. The Des detects the PRBS7 pattern and monitors it for errors. The PASS output pin toggles to flag any payloads that are received with 1 to 24 bit errors. The BISTM pin selects the operational mode of the PASS pin. If BISTM = L, the PASS pins reports the final result only. If BISTM = H, the PASS pins counts payload errors and also results the result. The result of the test is held on the PASS output until reset (new BIST test or Power Down). A high on PASS indicates NO ERRORS were detected. A Low on PASS indicates one or more errors were detected. The duration of the test is controlled by the pulse width applied to the Des BISTEN pin.

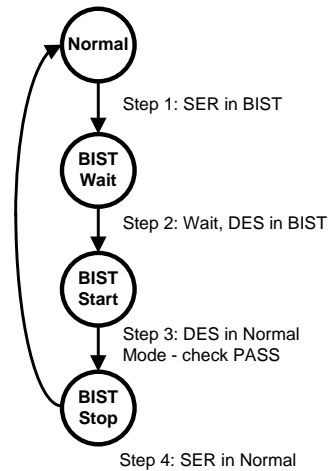

Figure 20. BIST Mode Flow Diagram

Sample BIST Sequence

See [Figure 20](#) for the BIST mode flow diagram.

- For the DS99R421 FPD-Link II Ser BIST Mode is enabled via the BISTEN pin. For the DS90UR241 Ser, BIST mode is entered by setting all the input data of the device to Low state. A PCLK is required for all the Ser options. When the Des detects the BIST mode pattern and command (DCA and DCB code) the RGB and control signal outputs are shut off.
- Place the DS99R124Q Des in BIST mode by setting the BISTEN = H. The Des is now in the BIST mode. If BISTM = H, the Des will check the incoming serial payloads for errors. If an error in the payload (1 to 24) is detected, the PASS pin will switch low for one half of the clock period. During the BIST test, the PASS output can be monitored and counted to determine the payload error rate.
- To Stop the BIST mode, the Des BISTEN pin is set Low. The Des stops checking the data. The final test result is held on the PASS pin. If the test ran error free, the PASS output will be High. If there was one or more errors detected, the PASS output will be Low. The PASS output state is held until a new BIST is run, the device is RESET, or Powered Down. The BIST duration is user controlled by the duration of the BISTEN signal.
- To return the link to normal operation, the Ser BISTEN input is set Low. The Link returns to normal operation.

[Figure 21](#) shows the waveform diagram of a typical BIST test for two cases. Case 1 is error free, and Case 2 shows one with multiple errors. In most cases it is difficult to generate errors due to the robustness of the link (differential data transmission etc.), thus they may be introduced by greatly extending the cable length, faulting the interconnect, reducing signal condition enhancements (De-Emphasis, VODSEL, or Rx Equalization).

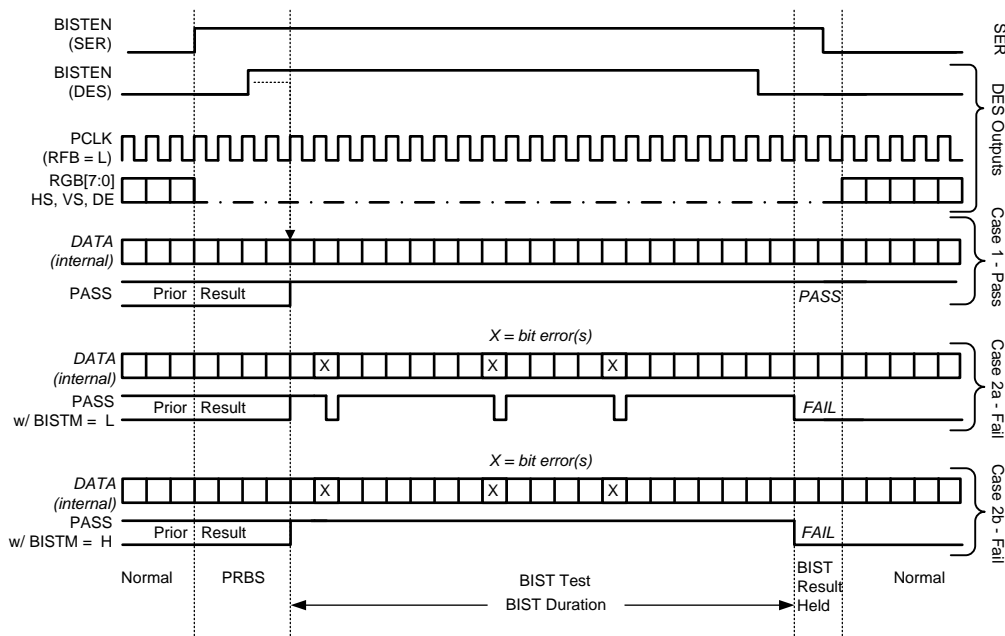

Figure 21. BIST Waveforms

Serial Bus Control — Optional

The DS99R124 may also be configured by the use of a serial control bus that is I2C protocol compatible. By default, the I2C reg_0x00'h is set to 00'h and all configuration is set by control/strap pins. A write of 01'h to reg_0x00'h will enable/allow configuration by registers; this will override the control/strap pins. Multiple devices may share the serial control bus since multiple addresses are supported. See Figure 22.

The serial bus is comprised of three pins. The SCL is a Serial Bus Clock Input. The SDA is the Serial Bus Data Input / Output signal. Both SCL and SDA signals require an external pull up resistor to V_{DDIO} . For most applications a 4.7 k pull up resistor to V_{DDIO} may be used. The resistor value may be adjusted for capacitive loading and data rate requirements. The signals are either pulled High, or driven Low.

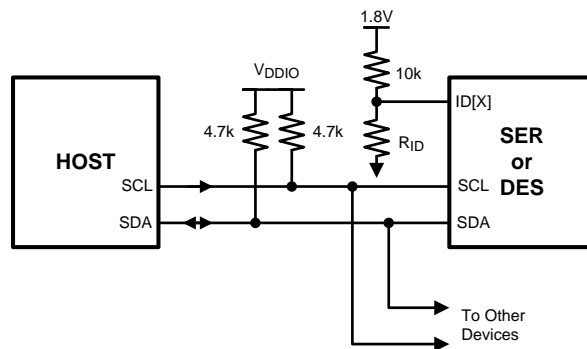

Figure 22. Serial Control Bus Connection

The third pin is the ID[X] pin. This pin sets one of four possible device addresses. Two different connections are possible. The pin may be pulled to V_{DD} (1.8V, NOT V_{DDIO}) with a 10 k Ω resistor. Or a 10 k Ω pull up resistor (to V_{DD} 1.8V, NOT V_{DDIO}) and a pull down resistor of the recommended value to set other three possible addresses may be used. See Table 5 for the Des.

The Serial Bus protocol is controlled by START, START-Repeated, and STOP phases. A START occurs when SCL transitions Low while SDA is High. A STOP occurs when SDA transition High while SCL is also HIGH. See Figure 23

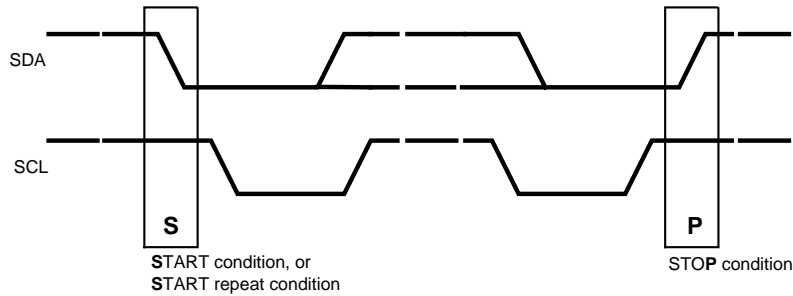

Figure 23. START and STOP Conditions

To communicate with a remote device, the host controller (master) sends the slave address and listens for a response from the slave. This response is referred to as an acknowledge bit (ACK). If a slave on the bus is addressed correctly, it Acknowledges (ACKs) the master by driving the SDA bus low. If the address doesn't match a device's slave address, it Not-acknowledges (NACKs) the master by letting SDA be pulled High. ACKs also occur on the bus when data is being transmitted. When the master is writing data, the slave ACKs after every data byte is successfully received. When the master is reading data, the master ACKs after every data byte is received to let the slave know it wants to receive another data byte. When the master wants to stop reading, it NACKs after the last data byte and creates a stop condition on the bus. All communication on the bus begins with either a Start condition or a Repeated Start condition. All communication on the bus ends with a Stop condition. A READ is shown in [Figure 24](#) and a WRITE is shown in [Figure 25](#).

If the Serial Bus is not required, the three pins may be left open (NC).

Table 5. ID[x] Resistor Value – DS99R124Q Des

Resistor RID kΩ (5%tol)	Address 7'b	Address 8'b 0 appended (WRITE)
0.47	7b' 111 0001 (h'71)	8b' 1110 0010 (h'E2)
2.7	7b' 111 0010 (h'72)	8b' 1110 0100 (h'E4)
8.2	7b' 111 0011 (h'73)	8b' 1110 0110 (h'E6)
Open	7b' 111 0110 (h'76)	8b' 1110 1100 (h'EC)

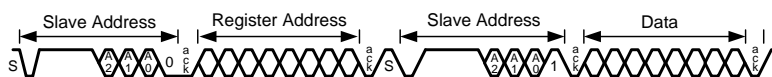

Figure 24. Serial Control Bus — READ

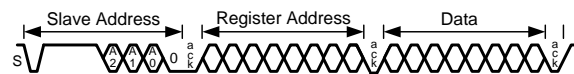

Figure 25. Serial Control Bus — WRITE

Table 6. DS99R124Q — Serial Bus Control Registers

ADD (dec)	ADD (hex)	Register Name	Bit(s)	R/W	Default (bin)	Function	Description
0	0	Des Config 1	7	R/W	0	LFMODE	SSCG Mode – low frequency support 0: 20 to 43 MHz Operation 1: 5 to 20 MHz Operation
			6	R/W	0	OSS_SEL	Output Sleep State Select TBD
			5	R/W	0	<i>Reserved</i>	<i>Reserved</i>
			4	R/W	0	<i>Reserved</i>	<i>Reserved</i>
			3:2	R/W	00	<i>Reserved</i>	<i>Reserved</i>
			1	R/W	0	SLEEP	Note – not the same function as <u>PowerDown</u> (PDB) 0: normal mode 1: Sleep Mode – Register settings retained.
			0	R/W	0	REG Control	0: Configurations set from control pins 1: Configurations set from registers (except I2C_ID)
1	1	Slave ID	7	R/W	0	ADD_SEL	0: Address from ID[X] Pin 1: Address from Register
			6:0	R/W	1110000	ID[X]	Serial Bus Device ID, Four IDs are: 7b '1110 001 (h'71); 8b '1110 0010 (h'E2) 7b '1110 010 (h'72); 8b '1110 0100 (h'E4) 7b '1110 011 (h'73); 8b '1110 0110 (h'E6) 7b '1110 110 (h'76); 8b '1110 1100 (h'EC) All other addresses are Reserved .
2	2	Des Features 1	7	R/W	0	OEN	Output Enable Input 0: FPD-Link output are TRI-STATE 1: FPD-Link outputs are enabled (active)
			6	R/W	0	<i>Reserved</i>	<i>Reserved</i>
			5:4	R/W	00	<i>Reserved</i>	<i>Reserved</i>
			3	R/W	0	VODSEL	Differential Driver Output Voltage Select 0: LVDS VOD is ± 250 mV, 500 mVp-p (typ) 1: LVDS VOD is ± 400 mV, 800 mVp-p (typ)
			2:0	R/W	00	OSC_SEL	000: OFF 001: Reserved 010: 25 MHz $\pm 40\%$ 011: 16.7 MHz $\pm 40\%$ 100: 12.5 MHz $\pm 40\%$ 101: 10 MHz $\pm 40\%$ 110: 8.3 MHz $\pm 40\%$ 111: 6.3 MHz $\pm 40\%$

Table 6. DS99R124Q — Serial Bus Control Registers (continued)

ADD (dec)	ADD (hex)	Register Name	Bit(s)	R/W	Default (bin)	Function	Description
3	3	Des Features 2	7:5	R/W	000	EQ Gain	000: ~-1.625 dB 001: ~-3.25 dB 010: ~-4.87 dB 011: ~-6.5 dB 100: ~-8.125 dB 101: ~-9.75 dB 110: ~-11.375 dB 111: ~-13 dB
			4	R/W	0	EQ Enable	0: EQ = disabled 1: EQ = enabled
			3	R/W	0	Reserved	Reserved
			2:0	R/W	000	SSC	IF LFMODE = 0, then: 000: SSCG OFF 001: fdev = ±0.9%, fmod = CLK/2168 010: fdev = ±1.2%, fmod = CLK/2168 011: fdev = ±1.9%, fmod = CLK/2168 100: fdev = ±2.3%, fmod = CLK/2168 101: fdev = ±0.7%, fmod = CLK/1300 110: fdev = ±1.3%, fmod = CLK/1300 111: fdev = ±1.57%, fmod = CLK/1300 IF LFMODE = 1, then: 000: SSCG OFF 001: fdev = ±0.7%, fmod = CLK/625 010: fdev = ±1.3%, fmod = CLK/625 011: fdev = ±1.8%, fmod = CLK/625 100: fdev = ±2.2%, fmod = CLK/625 101: fdev = ±0.7%, fmod = CLK/385 110: fdev = ±1.2%, fmod = CLK/385 111: fdev = ±1.7%, fmod = CLK/385

APPLICATIONS INFORMATION

DISPLAY APPLICATION

The DS99R124Q, in conjunction with the DS99R421Q or DS90UR241Q, is intended for interfacing between a host (graphics processor) and a Display. It supports an 18-bit color depth (RGB666) and up to WVGA display formats. In a RGB666 application, 18 color bits (R[5:0], G[5:0], B[5:0]), Pixel Clock (PCLK) and three control bits (VS, HS and DE) are supported across the serial link with PCLK rates from 5 to 43MHz.

TYPICAL APPLICATION CONNECTION

Figure 26 shows a typical application of the DS99R124QQ Des in pin mode for a 43 MHz WVGA Display Application. The LVDS inputs utilize 100 nF coupling capacitors to the line and the Receiver provides internal termination. Bypass capacitors are placed near the power supply pins. Ferrite beads are placed on the power lines for effective noise suppression.

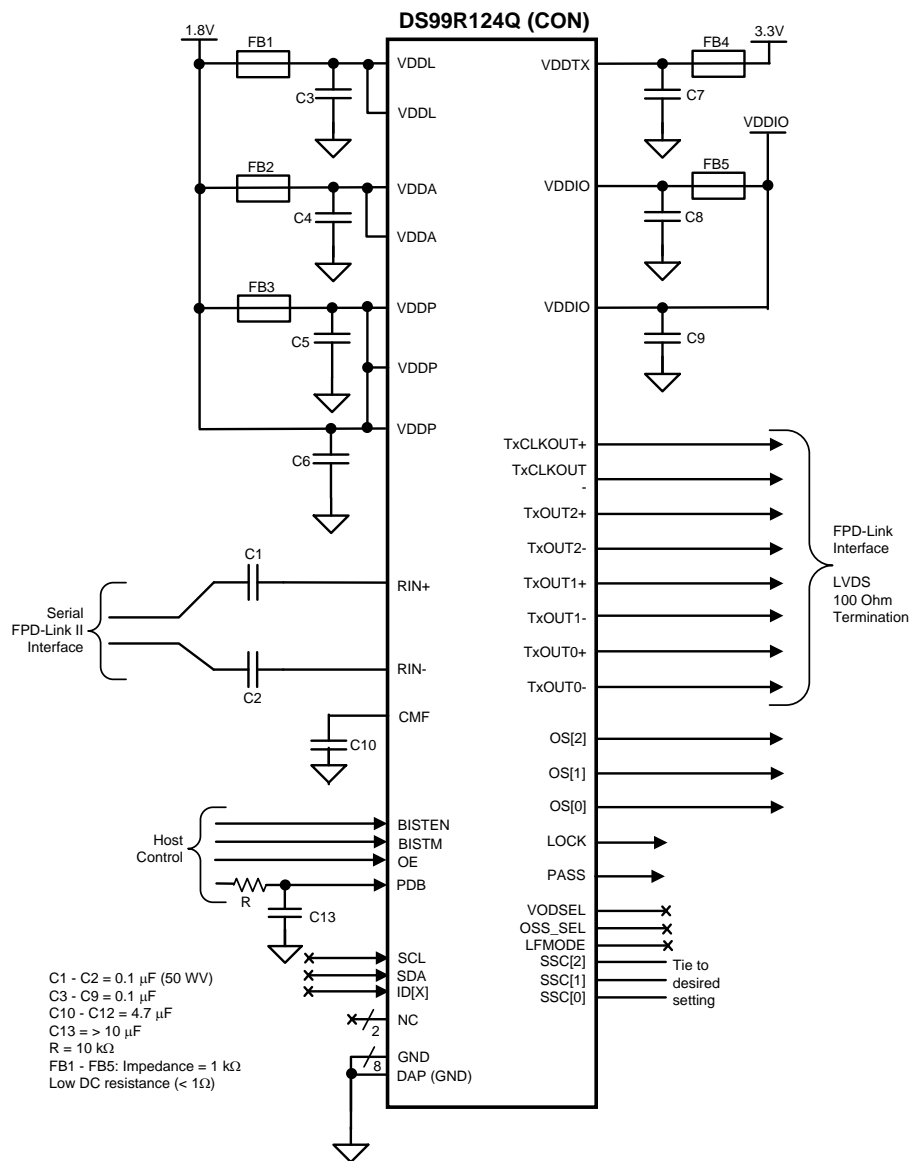

Figure 26. DS99R124Q Typical Connection Diagram — Pin Control

POWER UP REQUIREMENTS AND PDB PIN

The VDD (V_{DDn}), V_{DDTX} and V_{DDIO} supply ramps should be faster than 1.5 ms with a monotonic rise. Supplies may power up in any order, however device operation should be initiated only after all supplies are in their valid operating ranges. The optional serial bus address selection is done upon power up also. Thus, if using this optional feature, the PDB signal must be delayed to allow time for the ID setting to occur. The delay may be done by simply holding the PDB pin at a Low, or with an external RC delay based off the V_{DDIO} rail which would then need to lag the others in time. If the PDB pin is pulled to V_{DDIO} , it is recommended to use a 10 k Ω pull-up and a 10 μ F cap to GND to delay the PDB input signal.

TRANSMISSION MEDIA

The Ser/Des chipset is intended to be used in a point-to-point configuration, through a PCB trace, or through twisted pair cable. The Ser and Des provide internal terminations providing a clean signaling environment. The interconnect for LVDS should present a differential impedance of 100 Ohms. Use cables and connectors that have matched differential impedance to minimize impedance discontinuities. Shielded or un-shielded cables may be used depending upon the noise environment and application requirements.

LIVE LINK INSERTION

The Ser and Des devices support live pluggable applications. The automatic receiver lock to random data “plug & go” hot insertion capability allows the DS99R124Q to attain lock to the active data stream during a live insertion event.

PCB LAYOUT AND POWER SYSTEM CONSIDERATIONS

Circuit board layout and stack-up for the LVDS Ser/Des devices should be designed to provide low-noise power feed to the device. Good layout practice will also separate high frequency or high-level inputs and outputs to minimize unwanted stray noise pickup, feedback and interference. Power system performance may be greatly improved by using thin dielectrics (2 to 4 mils) for power / ground sandwiches. This arrangement provides plane capacitance for the PCB power system with low-inductance parasitics, which has proven especially effective at high frequencies, and makes the value and placement of external bypass capacitors less critical. External bypass capacitors should include both RF ceramic and tantalum electrolytic types. RF capacitors may use values in the range of 0.01 μ F to 0.1 μ F. Tantalum capacitors may be in the 2.2 μ F to 10 μ F range. Voltage rating of the tantalum capacitors should be at least 5X the power supply voltage being used.

Surface mount capacitors are recommended due to their smaller parasitics. When using multiple capacitors per supply pin, locate the smaller value closer to the pin. A large bulk capacitor is recommended at the point of power entry. This is typically in the 50 μ F to 100 μ F range and will smooth low frequency switching noise. It is recommended to connect power and ground pins directly to the power and ground planes with bypass capacitors connected to the plane with via on both ends of the capacitor. Connecting power or ground pins to an external bypass capacitor will increase the inductance of the path.

A small body size X7R chip capacitor, such as 0603, is recommended for external bypass. Its small body size reduces the parasitic inductance of the capacitor. The user must pay attention to the resonance frequency of these external bypass capacitors, usually in the range of 20-30 MHz. To provide effective bypassing, multiple capacitors are often used to achieve low impedance between the supply rails over the frequency of interest. At high frequency, it is also a common practice to use two vias from power and ground pins to the planes, reducing the impedance at high frequency.

Some devices provide separate power and ground pins for different portions of the circuit. This is done to isolate switching noise effects between different sections of the circuit. Separate planes on the PCB are typically not required. Pin Description tables typically provide guidance on which circuit blocks are connected to which power pin pairs. In some cases, an external filter may be used to provide clean power to sensitive circuits such as PLLs.

Use at least a four layer board with a power and ground plane. Locate LVCMOS signals away from the LVDS lines to prevent coupling from the LVCMOS lines to the LVDS lines. Closely-coupled differential lines of 100 Ohms are typically recommended for LVDS interconnect. The closely coupled lines help to ensure that coupled noise will appear as common-mode and thus is rejected by the receivers. The tightly coupled lines will also radiate less.

Information on the WQFN style package is provided in Texas Instruments Note: AN-1187 ([SNOA401](#)).

LVDS INTERCONNECT GUIDELINES

See AN-1108 ([SNLA008](#)) and AN-905 ([SNLA035](#)) for full details.

- Use 100Ω coupled differential pairs
- Use the S/2S/3S rule in spacings
 - S = space between the pair
 - 2S = space between pairs
 - 3S = space to LVCMOS signal
- Minimize the number of Vias
- Use differential connectors when operating above 500Mbps line speed
- Maintain balance of the traces
- Minimize skew within the pair
- Terminate as close to the TX outputs and RX inputs as possible

Additional general guidance can be found in the LVDS Owner's Manual - available in PDF format from the TI web site at: <http://www.ti.com/ww/en/analog/interface/lvds.shtml>

REVISION HISTORY

Changes from Revision C (April 2013) to Revision D	Page
• Changed layout of National Data Sheet to TI format	25

PACKAGING INFORMATION

Orderable Device	Status (1)	Package Type	Package Drawing	Pins	Package Qty	Eco Plan (2)	Lead/Ball Finish	MSL Peak Temp (3)	Op Temp (°C)	Top-Side Markings (4)	Samples
DS99R124QSQ/NOPB	ACTIVE	WQFN	RHS	48	1000	Green (RoHS & no Sb/Br)	CU SN	Level-3-260C-168 HR	-40 to 105	DS99R124Q	Samples
DS99R124QSQE/NOPB	ACTIVE	WQFN	RHS	48	250	Green (RoHS & no Sb/Br)	CU SN	Level-3-260C-168 HR	-40 to 105	DS99R124Q	Samples
DS99R124QSQX/NOPB	ACTIVE	WQFN	RHS	48	2500	Green (RoHS & no Sb/Br)	CU SN	Level-3-260C-168 HR	-40 to 105	DS99R124Q	Samples

(1) The marketing status values are defined as follows:

ACTIVE: Product device recommended for new designs.

LIFEBUY: TI has announced that the device will be discontinued, and a lifetime-buy period is in effect.

NRND: Not recommended for new designs. Device is in production to support existing customers, but TI does not recommend using this part in a new design.

PREVIEW: Device has been announced but is not in production. Samples may or may not be available.

OBSOLETE: TI has discontinued the production of the device.

(2) Eco Plan - The planned eco-friendly classification: Pb-Free (RoHS), Pb-Free (RoHS Exempt), or Green (RoHS & no Sb/Br) - please check <http://www.ti.com/productcontent> for the latest availability information and additional product content details.

TBD: The Pb-Free/Green conversion plan has not been defined.

Pb-Free (RoHS): TI's terms "Lead-Free" or "Pb-Free" mean semiconductor products that are compatible with the current RoHS requirements for all 6 substances, including the requirement that lead not exceed 0.1% by weight in homogeneous materials. Where designed to be soldered at high temperatures, TI Pb-Free products are suitable for use in specified lead-free processes.

Pb-Free (RoHS Exempt): This component has a RoHS exemption for either 1) lead-based flip-chip solder bumps used between the die and package, or 2) lead-based die adhesive used between the die and leadframe. The component is otherwise considered Pb-Free (RoHS compatible) as defined above.

Green (RoHS & no Sb/Br): TI defines "Green" to mean Pb-Free (RoHS compatible), and free of Bromine (Br) and Antimony (Sb) based flame retardants (Br or Sb do not exceed 0.1% by weight in homogeneous material)

(3) MSL, Peak Temp. -- The Moisture Sensitivity Level rating according to the JEDEC industry standard classifications, and peak solder temperature.

(4) Multiple Top-Side Markings will be inside parentheses. Only one Top-Side Marking contained in parentheses and separated by a "~" will appear on a device. If a line is indented then it is a continuation of the previous line and the two combined represent the entire Top-Side Marking for that device.

Important Information and Disclaimer: The information provided on this page represents TI's knowledge and belief as of the date that it is provided. TI bases its knowledge and belief on information provided by third parties, and makes no representation or warranty as to the accuracy of such information. Efforts are underway to better integrate information from third parties. TI has taken and continues to take reasonable steps to provide representative and accurate information but may not have conducted destructive testing or chemical analysis on incoming materials and chemicals. TI and TI suppliers consider certain information to be proprietary, and thus CAS numbers and other limited information may not be available for release.

In no event shall TI's liability arising out of such information exceed the total purchase price of the TI part(s) at issue in this document sold by TI to Customer on an annual basis.

TAPE AND REEL INFORMATION

QUADRANT ASSIGNMENTS FOR PIN 1 ORIENTATION IN TAPE



*All dimensions are nominal

Device	Package Type	Package Drawing	Pins	SPQ	Reel Diameter (mm)	Reel Width W1 (mm)	A0 (mm)	B0 (mm)	K0 (mm)	P1 (mm)	W (mm)	Pin1 Quadrant
DS99R124QSQ/NOPB	WQFN	RHS	48	1000	330.0	16.4	7.3	7.3	1.3	12.0	16.0	Q1
DS99R124QSQE/NOPB	WQFN	RHS	48	250	178.0	16.4	7.3	7.3	1.3	12.0	16.0	Q1
DS99R124QSQX/NOPB	WQFN	RHS	48	2500	330.0	16.4	7.3	7.3	1.3	12.0	16.0	Q1

TAPE AND REEL BOX DIMENSIONS

*All dimensions are nominal

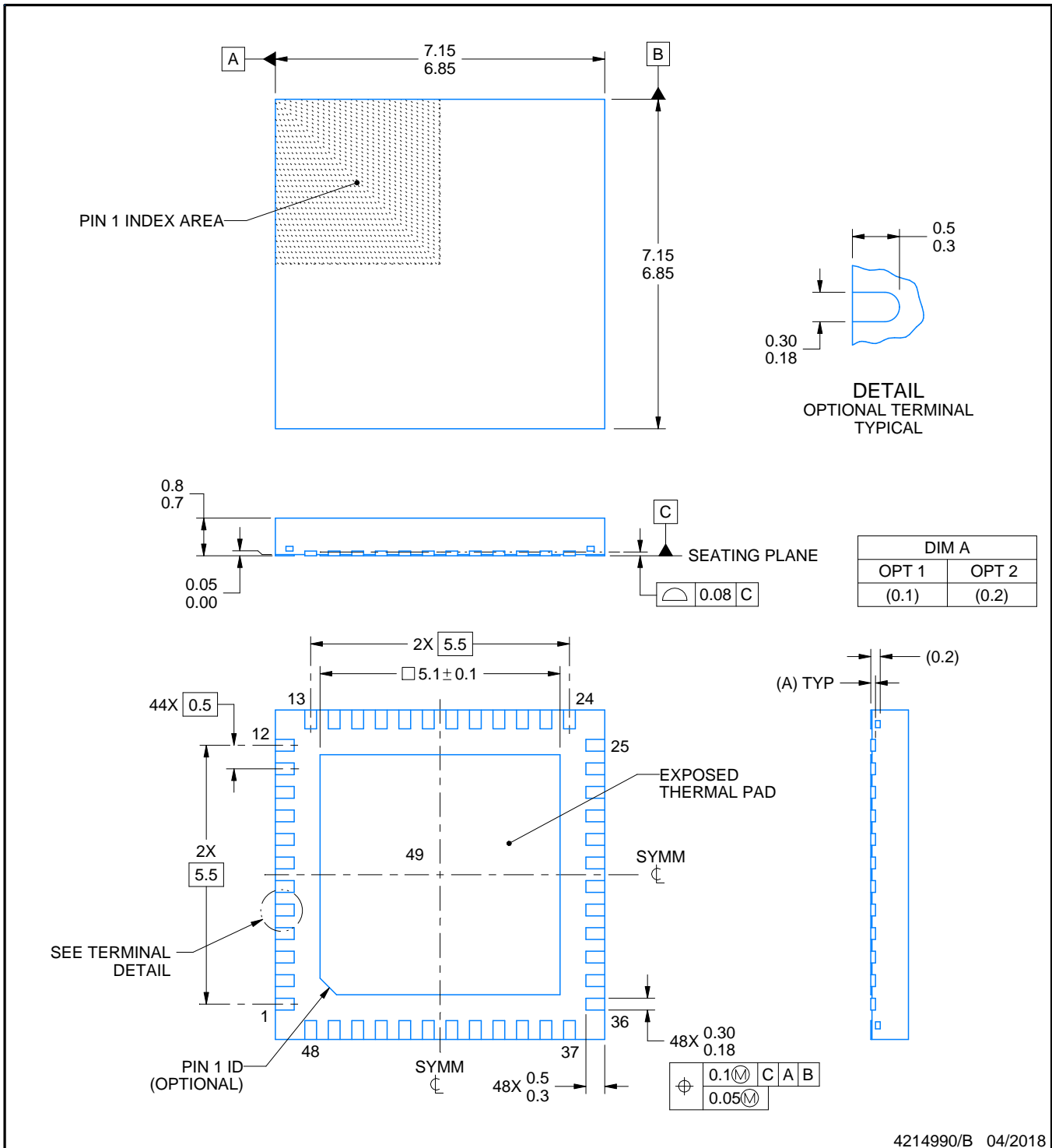
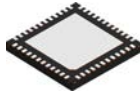
Device	Package Type	Package Drawing	Pins	SPQ	Length (mm)	Width (mm)	Height (mm)
DS99R124QSQ/NOPB	WQFN	RHS	48	1000	367.0	367.0	38.0
DS99R124QSQE/NOPB	WQFN	RHS	48	250	210.0	185.0	35.0
DS99R124QSQX/NOPB	WQFN	RHS	48	2500	367.0	367.0	38.0



4214990/B 04/2018

NOTES:

1. All linear dimensions are in millimeters. Any dimensions in parenthesis are for reference only. Dimensioning and tolerancing per ASME Y14.5M.
2. This drawing is subject to change without notice.
3. The package thermal pad must be soldered to the printed circuit board for thermal and mechanical performance.

EXAMPLE BOARD LAYOUT

RHS0048A

WQFN - 0.8 mm max height

PLASTIC QUAD FLATPACK - NO LEAD

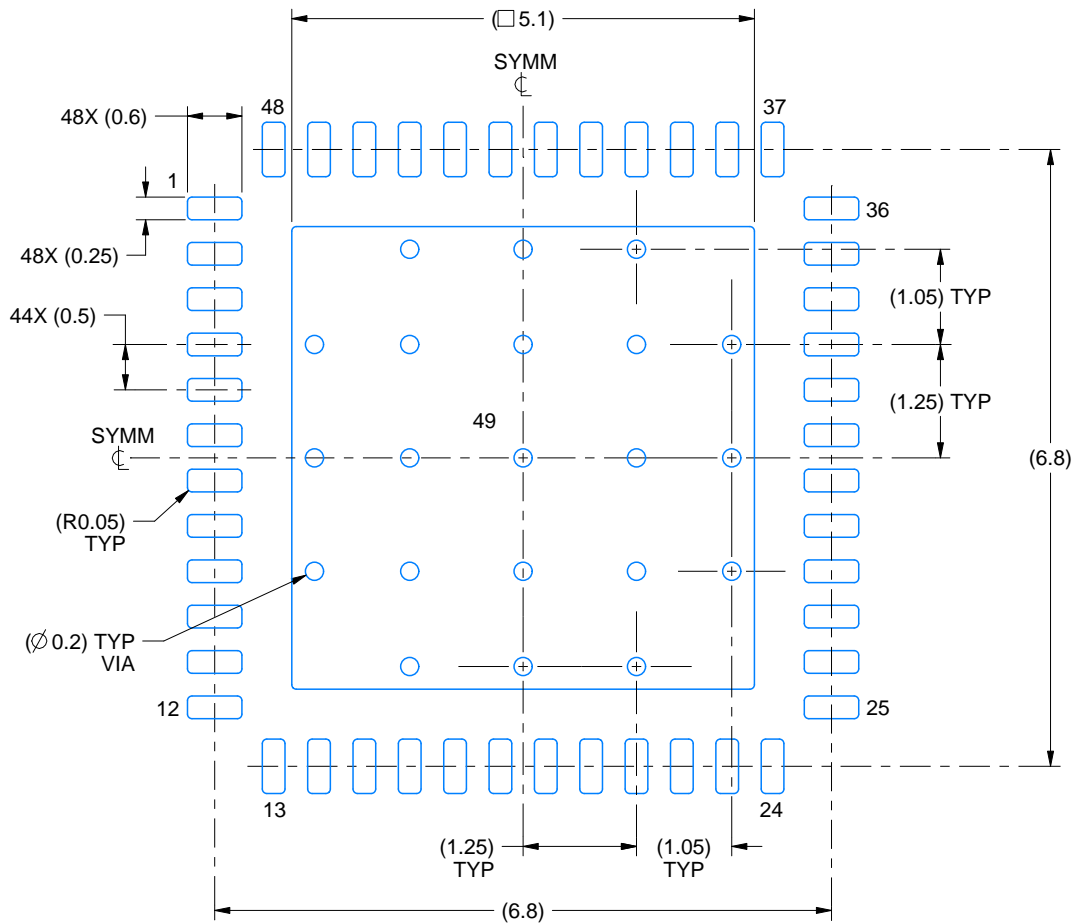

LAND PATTERN EXAMPLE
EXPOSED METAL SHOWN
SCALE:12X

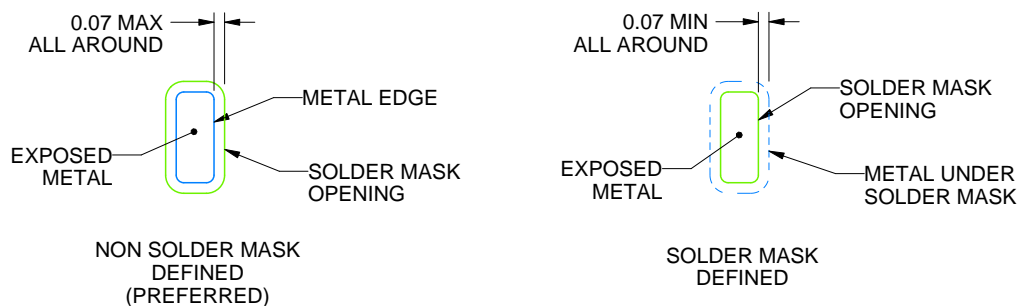

SOLDER MASK DETAILS

4214990/B 04/2018

NOTES: (continued)

4. This package is designed to be soldered to a thermal pad on the board. For more information, see Texas Instruments literature number SLUA271 (www.ti.com/lit/slua271).
5. Vias are optional depending on application, refer to device data sheet. If any vias are implemented, refer to their locations shown on this view. It is recommended that vias under paste be filled, plugged or tented.

EXAMPLE STENCIL DESIGN

RHS0048A

WQFN - 0.8 mm max height

PLASTIC QUAD FLATPACK - NO LEAD

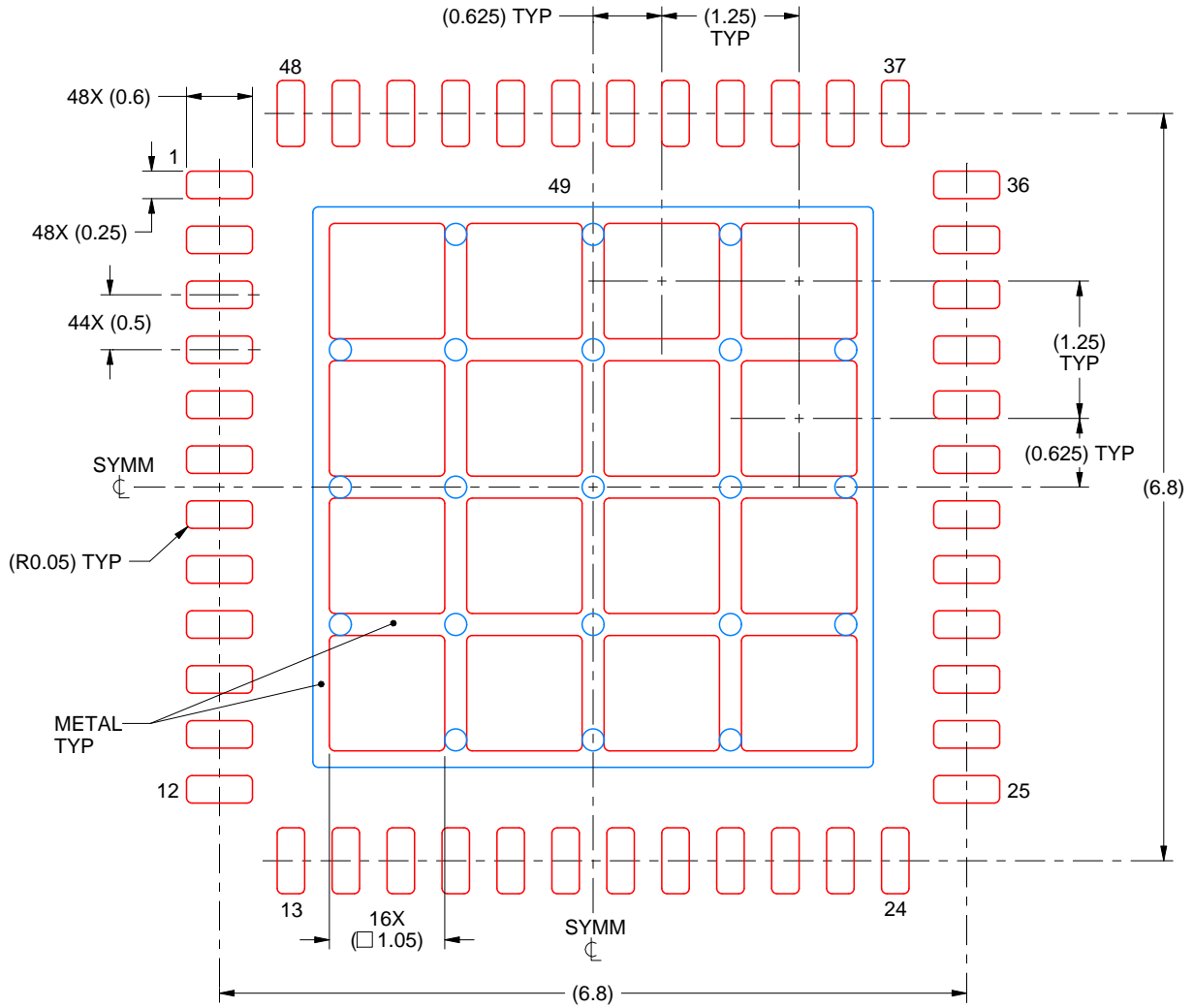

SOLDER PASTE EXAMPLE
 BASED ON 0.125 mm THICK STENCIL

EXPOSED PAD 49
 68% PRINTED SOLDER COVERAGE BY AREA UNDER PACKAGE
 SCALE:15X

4214990/B 04/2018

NOTES: (continued)

6. Laser cutting apertures with trapezoidal walls and rounded corners may offer better paste release. IPC-7525 may have alternate design recommendations.

IMPORTANT NOTICE

Texas Instruments Incorporated (TI) reserves the right to make corrections, enhancements, improvements and other changes to its semiconductor products and services per JESD46, latest issue, and to discontinue any product or service per JESD48, latest issue. Buyers should obtain the latest relevant information before placing orders and should verify that such information is current and complete.

TI's published terms of sale for semiconductor products (<http://www.ti.com/sc/docs/stdterms.htm>) apply to the sale of packaged integrated circuit products that TI has qualified and released to market. Additional terms may apply to the use or sale of other types of TI products and services.

Reproduction of significant portions of TI information in TI data sheets is permissible only if reproduction is without alteration and is accompanied by all associated warranties, conditions, limitations, and notices. TI is not responsible or liable for such reproduced documentation. Information of third parties may be subject to additional restrictions. Resale of TI products or services with statements different from or beyond the parameters stated by TI for that product or service voids all express and any implied warranties for the associated TI product or service and is an unfair and deceptive business practice. TI is not responsible or liable for any such statements.

Buyers and others who are developing systems that incorporate TI products (collectively, "Designers") understand and agree that Designers remain responsible for using their independent analysis, evaluation and judgment in designing their applications and that Designers have full and exclusive responsibility to assure the safety of Designers' applications and compliance of their applications (and of all TI products used in or for Designers' applications) with all applicable regulations, laws and other applicable requirements. Designer represents that, with respect to their applications, Designer has all the necessary expertise to create and implement safeguards that (1) anticipate dangerous consequences of failures, (2) monitor failures and their consequences, and (3) lessen the likelihood of failures that might cause harm and take appropriate actions. Designer agrees that prior to using or distributing any applications that include TI products, Designer will thoroughly test such applications and the functionality of such TI products as used in such applications.

TI's provision of technical, application or other design advice, quality characterization, reliability data or other services or information, including, but not limited to, reference designs and materials relating to evaluation modules, (collectively, "TI Resources") are intended to assist designers who are developing applications that incorporate TI products; by downloading, accessing or using TI Resources in any way, Designer (individually or, if Designer is acting on behalf of a company, Designer's company) agrees to use any particular TI Resource solely for this purpose and subject to the terms of this Notice.

TI's provision of TI Resources does not expand or otherwise alter TI's applicable published warranties or warranty disclaimers for TI products, and no additional obligations or liabilities arise from TI providing such TI Resources. TI reserves the right to make corrections, enhancements, improvements and other changes to its TI Resources. TI has not conducted any testing other than that specifically described in the published documentation for a particular TI Resource.

Designer is authorized to use, copy and modify any individual TI Resource only in connection with the development of applications that include the TI product(s) identified in such TI Resource. NO OTHER LICENSE, EXPRESS OR IMPLIED, BY ESTOPPEL OR OTHERWISE TO ANY OTHER TI INTELLECTUAL PROPERTY RIGHT, AND NO LICENSE TO ANY TECHNOLOGY OR INTELLECTUAL PROPERTY RIGHT OF TI OR ANY THIRD PARTY IS GRANTED HEREIN, including but not limited to any patent right, copyright, mask work right, or other intellectual property right relating to any combination, machine, or process in which TI products or services are used. Information regarding or referencing third-party products or services does not constitute a license to use such products or services, or a warranty or endorsement thereof. Use of TI Resources may require a license from a third party under the patents or other intellectual property of the third party, or a license from TI under the patents or other intellectual property of TI.

TI RESOURCES ARE PROVIDED "AS IS" AND WITH ALL FAULTS. TI DISCLAIMS ALL OTHER WARRANTIES OR REPRESENTATIONS, EXPRESS OR IMPLIED, REGARDING RESOURCES OR USE THEREOF, INCLUDING BUT NOT LIMITED TO ACCURACY OR COMPLETENESS, TITLE, ANY EPIDEMIC FAILURE WARRANTY AND ANY IMPLIED WARRANTIES OF MERCHANTABILITY, FITNESS FOR A PARTICULAR PURPOSE, AND NON-INFRINGEMENT OF ANY THIRD PARTY INTELLECTUAL PROPERTY RIGHTS. TI SHALL NOT BE LIABLE FOR AND SHALL NOT DEFEND OR INDEMNIFY DESIGNER AGAINST ANY CLAIM, INCLUDING BUT NOT LIMITED TO ANY INFRINGEMENT CLAIM THAT RELATES TO OR IS BASED ON ANY COMBINATION OF PRODUCTS EVEN IF DESCRIBED IN TI RESOURCES OR OTHERWISE. IN NO EVENT SHALL TI BE LIABLE FOR ANY ACTUAL, DIRECT, SPECIAL, COLLATERAL, INDIRECT, PUNITIVE, INCIDENTAL, CONSEQUENTIAL OR EXEMPLARY DAMAGES IN CONNECTION WITH OR ARISING OUT OF TI RESOURCES OR USE THEREOF, AND REGARDLESS OF WHETHER TI HAS BEEN ADVISED OF THE POSSIBILITY OF SUCH DAMAGES.

Unless TI has explicitly designated an individual product as meeting the requirements of a particular industry standard (e.g., ISO/TS 16949 and ISO 26262), TI is not responsible for any failure to meet such industry standard requirements.

Where TI specifically promotes products as facilitating functional safety or as compliant with industry functional safety standards, such products are intended to help enable customers to design and create their own applications that meet applicable functional safety standards and requirements. Using products in an application does not by itself establish any safety features in the application. Designers must ensure compliance with safety-related requirements and standards applicable to their applications. Designer may not use any TI products in life-critical medical equipment unless authorized officers of the parties have executed a special contract specifically governing such use. Life-critical medical equipment is medical equipment where failure of such equipment would cause serious bodily injury or death (e.g., life support, pacemakers, defibrillators, heart pumps, neurostimulators, and implantables). Such equipment includes, without limitation, all medical devices identified by the U.S. Food and Drug Administration as Class III devices and equivalent classifications outside the U.S.

TI may expressly designate certain products as completing a particular qualification (e.g., Q100, Military Grade, or Enhanced Product). Designers agree that it has the necessary expertise to select the product with the appropriate qualification designation for their applications and that proper product selection is at Designers' own risk. Designers are solely responsible for compliance with all legal and regulatory requirements in connection with such selection.

Designer will fully indemnify TI and its representatives against any damages, costs, losses, and/or liabilities arising out of Designer's non-compliance with the terms and provisions of this Notice.

Looking for pricing, stock, or lifecycle information?

Click below to explore more details on WIN SOURCE:

 [View DS99R124QSQ/NOPB on WIN SOURCE](#)

 [Texas Instruments](#) Information

Optimize Your Supply Chain with WIN SOURCE Solutions

-  Global Sourcing Solution
-  Obsolete Management
-  Cost Control Management
-  Shortage Management
-  Alternative Solution
-  Excess Inventory Management