



**THE DATASHEET OF
DS99R103TSQX/NOPB**



DS99R103/DS99R104 3-40MHz DC-Balanced 24-Bit LVDS Serializer and Deserializer

Check for Samples: [DS99R103](#), [DS99R104](#)

FEATURES

- **3 MHz–40 MHz Clock Embedded and DC-Balancing 24:1 and 1:24 Data Transmissions**
- **Capable to Drive Shielded Twisted-Pair Cable**
- **User Selectable Clock Edge for Parallel Data on both Transmitter and Receiver**
- **Internal DC Balancing Encode/Decode – Supports AC-Coupling Interface with no External Coding Required**
- **Individual Power-Down Controls for both Transmitter and Receiver**
- **Embedded Clock CDR (Clock and Data Recovery) on Receiver and no External Source of Reference Clock Needed**
- **All Codes RDL (Random Data Lock) to Support Live-Pluggable Applications**
- **LOCK Output Flag to Ensure Data Integrity at Receiver Side**
- **Balanced T_{SETUP}/T_{HOLD} Between RCLK and RDATA on Receiver Side**
- **PTO (Progressive Turn-On) LVCMOS Outputs to Reduce EMI and Minimize SSO Effects**
- **All LVCMOS inputs and control pins have internal pulldown**
- **On-Chip Filters for PLLs on Transmitter and Receiver**
- **Integrated 100 Ω Input Termination on Receiver**
- **4 mA Receiver Output Drive**
- **48-Pin TQFP and 48-Pin WQFN Packages**
- **Pure CMOS .35 μ m Process**
- **Power Supply Range 3.3V \pm 10%**
- **Temperature Range –40°C to +85°C**
- **8 kV HBM ESD Tolerance**

DESCRIPTION

The DS99R103/DS99R104 Chipset translates a 24-bit parallel bus into a fully transparent data/control LVDS serial stream with embedded clock information. This single serial stream simplifies transferring a 24-bit bus over PCB traces and cable by eliminating the skew problems between parallel data and clock paths. It saves system cost by narrowing data paths that in turn reduce PCB layers, cable width, and connector size and pins.

The DS99R103/DS99R104 incorporates LVDS signaling on the high-speed I/O. LVDS provides a low power and low noise environment for reliably transferring data over a serial transmission path. By optimizing the serializer output edge rate for the operating frequency range EMI is further reduced.

In addition the device features pre-emphasis to boost signals over longer distances using lossy cables. Internal DC balanced encoding/decoding is used to support AC-Coupled interconnects.



Please be aware that an important notice concerning availability, standard warranty, and use in critical applications of Texas Instruments semiconductor products and disclaimers thereto appears at the end of this data sheet.

All trademarks are the property of their respective owners.

Block Diagram

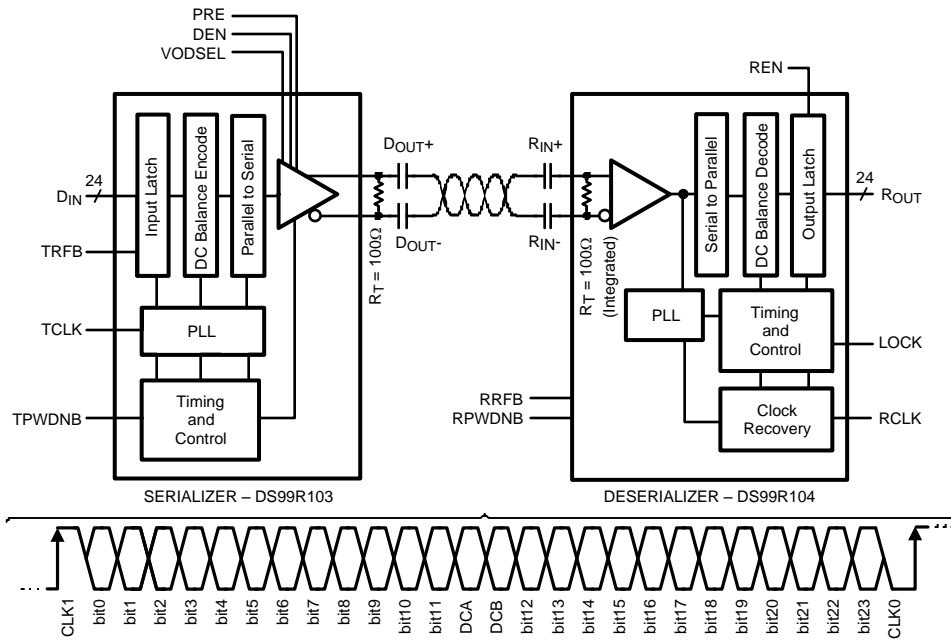

These devices have limited built-in ESD protection. The leads should be shorted together or the device placed in conductive foam during storage or handling to prevent electrostatic damage to the MOS gates.

Absolute Maximum Ratings⁽¹⁾⁽²⁾

Supply Voltage (V_{DD})	-0.3V to +4V
LVC MOS/LVTTL Input Voltage	-0.3V to ($V_{DD} + 0.3V$)
LVC MOS/LVTTL Output Voltage	-0.3V to ($V_{DD} + 0.3V$)
LVDS Receiver Input Voltage	-0.3V to 3.9V
LVDS Driver Output Voltage	-0.3V to 3.9V
LVDS Output Short Circuit Duration	10 ms
Junction Temperature	+150°C
Storage Temperature	-65°C to +150°C
Lead Temperature (Soldering, 4 seconds)	+260°C
Maximum Package Power Dissipation Capacity Package De-rating:	
48L TQFP	$1/\theta_{JA}$ °C/W above +25°C
DS99R103	
θ_{JA}	45.8 ⁽³⁾ ; 75.4 ⁽⁴⁾ °C/W
θ_{JC}	21.0°C/W
DS99R104	
θ_{JA}	45.4 ⁽³⁾ ; 75.0 ⁽⁴⁾ °C/W
θ_{JC}	21.1°C/W
48L WQFN	$1/\theta_{JA}$ °C/W above +25°C
DS99R103	
θ_{JA}	28 ⁽³⁾ 79.1 ⁽⁴⁾ °C/W
θ_{JC}	3.7°C/W
DS99R104	
θ_{JA}	28 ⁽³⁾ ; 79.1 ⁽⁴⁾ °C/W
θ_{JC}	3.71°C/W
ESD Rating (HBM)	≥±8 kV

- (1) "Absolute Maximum Ratings" indicate limits beyond which damage to the device may occur, including inoperability and degradation of device reliability and/or performance. Functional operation of the device and/or non-degradation at the Absolute Maximum Ratings or other conditions beyond those indicated in the Recommended Operating Conditions is not implied. The Recommended Operating Conditions indicate conditions at which the device is functional and the device should not be operated beyond such conditions.
- (2) If Military/Aerospace specified devices are required, please contact the Texas Instruments Sales Office/ Distributors for availability and specifications.
- (3) 4L JEDEC
- (4) 2L JEDEC

Recommended Operating Conditions

	Min	Nom	Max	Units
Supply Voltage (V_{DD})	3.0	3.3	3.6	V
Operating Free Air Temperature (T_A)	-40	+25	+85	°C
Clock Rate	3		40	MHz
Supply Noise			±100	mV _{P-P}

Electrical Characteristics⁽¹⁾⁽²⁾⁽³⁾

Over recommended operating supply and temperature ranges unless otherwise specified.

Parameter	Test Conditions	Pin/Freq.	Min	Typ	Max	Units	
LVCMOS/LVTTL DC SPECIFICATIONS							
V _{IH}	High Level Voltage	Tx: DIN[23:0], TCLK, TPWDNB, DEN, TRFB, DCAOFF, DCBOFF, VODSEL Rx: RPWDNB, RRFB, REN	2.0	1.5	V _{DD}	V	
V _{IL}	Low Level Input Voltage		GND	1.5	0.8	V	
V _{CL}	Input Clamp Voltage		I _{CL} = -18 mA ⁽⁴⁾		-0.8	-1.5	V
I _{IN}	Input Current	V _{IN} = 0V or 3.6V	Tx: DIN[23:0], TCLK, TPWDNB, DEN, TRFB, DCAOFF, DCBOFF, VODSEL Rx: RPWDNB, RRFB, REN	-10	±1	+10	μA
V _{OH}	High Level Output Voltage	Rx: ROUT[23:0], RCLK, LOCK	2.3	3.0	V _{DD}	V	
V _{OL}	Low Level Output Voltage		GND	0.33	0.5	V	
I _{OS}	Output Short Circuit Current		V _{OUT} = 0V ⁽⁴⁾	-40	-70	-110	mA
I _{OZ}	TRI-STATE Output Current	RPWDNB, REN = 0V V _{OUT} = 0V or 2.4V	Rx: ROUT[23:0], RCLK, LOCK	-30	±0.4	+30	μA
LVDS DC SPECIFICATIONS							
V _{TH}	Differential Threshold High Voltage	V _{CM} = +1.2V	Rx: R _{IN+} , R _{IN-}			+50	mV
V _{TL}	Differential Threshold Low Voltage			-50			mV
I _{IN}	Input Current	V _{IN} = +2.4V, V _{DD} = 3.6V				±300	μA
		V _{IN} = 0V, V _{DD} = 3.6V				±300	μA
R _T	Differential Internal Termination Resistance			90	100	130	Ω
V _{OD}	Output Differential Voltage (D _{OUT+})-(D _{OUT-})	R _L = 100Ω, w/o Pre-emphasis VODSEL = L (Figure 10)	Tx: D _{OUT+} , D _{OUT-}	250	400	600	mV
		R _L = 100Ω, w/o Pre-emphasis VODSEL = H (Figure 10)		450	750	1200	mV
ΔV _{OD}	Output Differential Voltage Unbalance	R _L = 100Ω, w/o Pre-emphasis			4	50	mV
V _{OS}	Offset Voltage	R _L = 100Ω, w/o Pre-emphasis		1.00	1.25	1.50	V
ΔV _{OS}	Offset Voltage Unbalance	R _L = 100Ω, w/o Pre-emphasis			1	50	mV
I _{OS}	Output Short Circuit Current	DOUT = 0V, DIN = H, TPWDNB, DEN = 2.4V, VODSEL = L		-2	-5	-8	mA
		DOUT = 0V, DIN = H, TPWDNB, DEN = 2.4V, VODSEL = H		-7	-10	-13	mA
I _{OZ}	TRI-STATE Output Current	TPWDNB, DEN = 0V, DOUT = 0V or 2.4V	-15	±1	+15	μA	

- (1) The Electrical Characteristics tables list ensured specifications under the listed Recommended Operating Conditions except as otherwise modified or specified by the Electrical Characteristics Conditions and/or Notes. Typical specifications are estimations only and are not ensured.
- (2) Typical values represent most likely parametric norms at V_{DD} = 3.3V, T_A = +25 degC, and at the Recommended Operation Conditions at the time of product characterization and are not ensured.
- (3) Current into device pins is defined as positive. Current out of a device pin is defined as negative. Voltages are referenced to ground except V_{OD}, ΔV_{OD}, V_{TH} and V_{TL} which are differential voltages.
- (4) Specification is ensured by characterization and is not tested in production.

Electrical Characteristics⁽¹⁾⁽²⁾⁽³⁾ (continued)

Over recommended operating supply and temperature ranges unless otherwise specified.

Parameter		Test Conditions	Pin/Freq.	Min	Typ	Max	Units
SER/DES SUPPLY CURRENT (DVDD*, PVDD* and AVDD* pins) *Digital, PLL, and Analog VDDs							
I _{DDT}	Serializer (Tx) Total Supply Current (includes load current)	R _L = 100Ω Pre-emphasis = OFF VODSEL = L Checker-board pattern (Figure 1)	f = 40 MHz		40	80	mA
		R _L = 100Ω R _{PRE} = 6 kΩ VODSEL = L Checker-board pattern (Figure 1)	f = 40 MHz		45	85	mA
	Serializer (Tx) Total Supply Current (includes load current)	R _L = 100Ω Pre-emphasis = OFF VODSEL = H Checker-board pattern (Figure 1)	f = 40 MHz		40	85	mA
		R _L = 100Ω R _{PRE} = 6 kΩ VODSEL = H Checker-board pattern (Figure 1)	f = 40 MHz		45	90	mA
I _{DDTZ}	Serializer (Tx) Supply Current Power-down	TPWDNB = 0V (All other LVCMOS Inputs = 0V)		14	250	μA	
I _{DDR}	Deserializer (Rx) Total Supply Current (includes load current)	C _L = 8 pF LVCMOS Output Checker-board pattern (Figure 2)	f = 40 MHz			95	mA
	Deserializer (Rx) Total Supply Current (includes load current)	C _L = 8 pF LVCMOS Output Random pattern	f = 40 MHz			90	mA
I _{DDRZ}	Deserializer (Rx) Supply Current Power-down	RPWDNB = 0V (All other LVCMOS Inputs = 0V, R _{IN+} / R _{IN-} = 0V)		1	50	μA	

Serializer Timing Requirements for TCLK⁽¹⁾⁽²⁾

Over recommended operating supply and temperature ranges unless otherwise specified.

Parameter		Test Conditions	Min	Typ	Max	Units
t _{TCP}	Transmit Clock Period	(Figure 5)	25	T	333	ns
t _{TClH}	Transmit Clock High Time		0.4T	0.5T	0.6T	ns
t _{TClL}	Transmit Clock Low Time		0.4T	0.5T	0.6T	ns
t _{CLKT}	TCLK Input Transition Time	(Figure 4)		3	6	ns
t _{JIT}	TCLK Input Jitter	See ⁽³⁾			33	ps (RMS)

(1) Figure 1, Figure 2, Figure 8, Figure 12, and Figure 14, show a falling edge data strobe (TCLK IN/RCLK OUT).

(2) Figure 5 and Figure 15 show a rising edge data strobe (TCLK IN/RCLK OUT).

 (3) t_{JIT} (@BER of 10e-9) specifies the allowable jitter on TCLK. t_{JIT} not included in TxOUT_E_O parameter.

Serializer Switching Characteristics

Over recommended operating supply and temperature ranges unless otherwise specified.

Parameter		Test Conditions	Min	Typ	Max	Units
t _{LLHT}	LVDS Low-to-High Transition Time	R _L = 100Ω, (Figure 3)			0.6	ns
t _{LHLT}	LVDS High-to-Low Transition Time	C _L = 10 pF to GND VODSEL = L			0.6	ns
t _{DIS}	DIN (23:0) Setup to TCLK	R _L = 100Ω,	5			ns
t _{DIH}	DIN (23:0) Hold from TCLK	C _L = 10 pF to GND ⁽¹⁾	5			ns

(1) Specification is ensured by characterization and is not tested in production.

Serializer Switching Characteristics (continued)

Over recommended operating supply and temperature ranges unless otherwise specified.

Parameter		Test Conditions	Min	Typ	Max	Units
t_{HZD}	DOUT \pm HIGH to TRI-STATE Delay	$R_L = 100\Omega$, $C_L = 10\text{ pF}$ to GND (Figure 6) ⁽²⁾			15	ns
t_{LZD}	DOUT \pm LOW to TRI-STATE Delay				15	ns
t_{ZHD}	DOUT \pm TRI-STATE to HIGH Delay				200	ns
t_{ZLD}	DOUT \pm TRI-STATE to LOW Delay				200	ns
t_{PLD}	Serializer PLL Lock Time	$R_L = 100\Omega$, (Figure 7)		10		ms
t_{SD}	Serializer Delay	$R_L = 100\Omega$, (Figure 8) VODSEL = L, TRFB = H		3.5T + 2.85	3.5T + 10	ns
		$R_L = 100\Omega$, (Figure 8) VODSEL = L, TRFB = L		3.5T + 2.85	3.5T + 10	ns
TxOUT_E_O	TxOUT_Eye_Opening (respect to ideal)	3–40 MHz (Figure 9) ⁽³⁾⁽⁴⁾		0.68		UI (5)

(2) When the Serializer output is at TRI-STATE, the Deserializer will lose PLL lock. Resynchronization MUST occur before data transfer.

(3) t_{JIT} (@BER of 10e-9) specifies the allowable jitter on TCLK. t_{JIT} not included in TxOUT_E_O parameter.

(4) TxOUT_E_O is affected by pre-emphasis value.

(5) UI – Unit Interval, equivalent to one ideal serialized data bit width. The UI scales with frequency.

Deserializer Switching Characteristics

Over recommended operating supply and temperature ranges unless otherwise specified.

Parameter	Test Conditions	Pin/Freq.	Min	Typ	Max	Units
t_{RCP}	Receiver out Clock Period	$t_{RCP} = t_{TCP}$ ⁽¹⁾	RCLK	25	T	333 ns
t_{RDC}	RCLK Duty Cycle		RCLK	45	50	55 %
t_{CLH}	LVC MOS Low-to-High Transition Time	$C_L = 8\text{ pF}$ (lumped load) (Figure 11)	ROUT [23:0], LOCK, RCLK		2.5	3.5 ns
t_{CHL}	LVC MOS High-to-Low Transition Time				2.5	3.5 ns
t_{ROS}	ROUT (7:0) Setup Data to RCLK (Group 1)	(Figure 15)	ROUT [7:0]	(0.40)* t_{RCP}	(29/56)* t_{RCP}	ns
t_{ROH}	ROUT (7:0) Hold Data to RCLK (Group 1)			(0.40)* t_{RCP}	(27/56)* t_{RCP}	ns
t_{ROS}	ROUT (15:8) Setup Data to RCLK (Group 2)	(Figure 15)	ROUT [15:8], LOCK	(0.40)* t_{RCP}	0.5* t_{RCP}	ns
t_{ROH}	ROUT (15:8) Hold Data to RCLK (Group 2)			(0.40)* t_{RCP}	0.5* t_{RCP}	ns
t_{ROS}	ROUT (23:16) Setup Data to RCLK (Group 3)	(Figure 15)	ROUT [23:16]	(0.40)* t_{RCP}	(27/56)* t_{RCP}	ns
t_{ROH}	ROUT (23:16) Hold Data to RCLK (Group 3)			(0.40)* t_{RCP}	(29/56)* t_{RCP}	ns
t_{HZR}	HIGH to TRI-STATE Delay	(Figure 13)	ROUT [23:0], RCLK, LOCK		3	10 ns
t_{LZR}	LOW to TRI-STATE Delay				3	10 ns
t_{ZHR}	TRI-STATE to HIGH Delay				3	10 ns
t_{ZLR}	TRI-STATE to LOW Delay				3	10 ns
t_{DD}	Deserializer Delay	(Figure 12)	RCLK		[4+(3/56)]T +5.9	[4+(3/56)]T +18.5 ns
t_{DRDL}	Deserializer PLL Lock Time from Powerdown	(Figure 14) ⁽²⁾⁽¹⁾	3 MHz		5	50 ms
			40 MHz		5	50 ms
RxIN_TOL_L	Receiver INput TOLerance Left	(Figure 16) ⁽³⁾⁽¹⁾⁽⁴⁾	3 MHz–40 MHz			0.25 UI
RxIN_TOL_R	Receiver INput TOLerance Right	(Figure 16) ⁽³⁾⁽¹⁾⁽⁴⁾	3 MHz–40 MHz			0.25 UI

(1) Specification is ensured by characterization and is not tested in production.

(2) The Deserializer PLL lock time (t_{DRDL}) may vary depending on input data patterns and the number of transitions within the pattern.

(3) RxIN_TOL is a measure of how much phase noise (jitter) the deserializer can tolerate in the incoming data stream before bit errors occur. It is a measurement in reference with the ideal bit position, please see TI's AN-1217 (Literature Number SNLA053) for detail.

(4) UI – Unit Interval, equivalent to one ideal serialized data bit width. The UI scales with frequency.

AC Timing Diagrams and Test Circuits

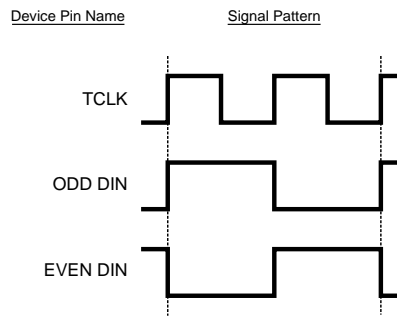

Figure 1. Serializer Input Checker-board Pattern

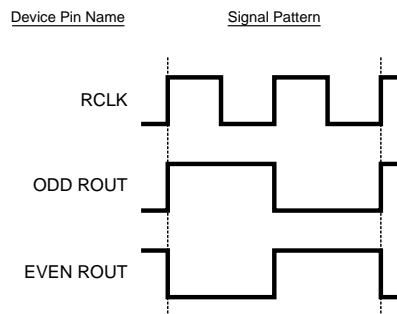

Figure 2. Deserializer Output Checker-board Pattern

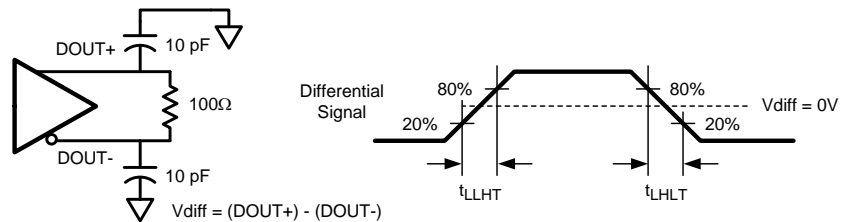

Figure 3. Serializer LVDS Output Load and Transition Times

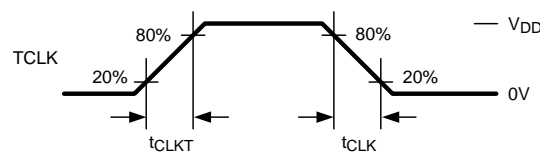

Figure 4. Serializer Input Clock Transition Times

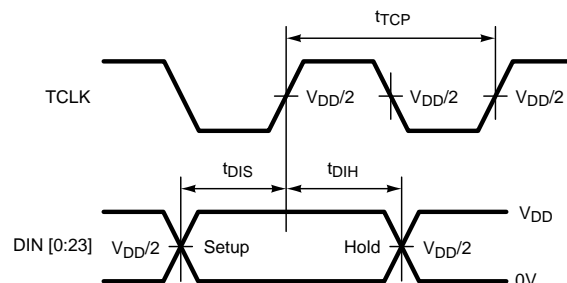

Figure 5. Serializer Setup/Hold Times

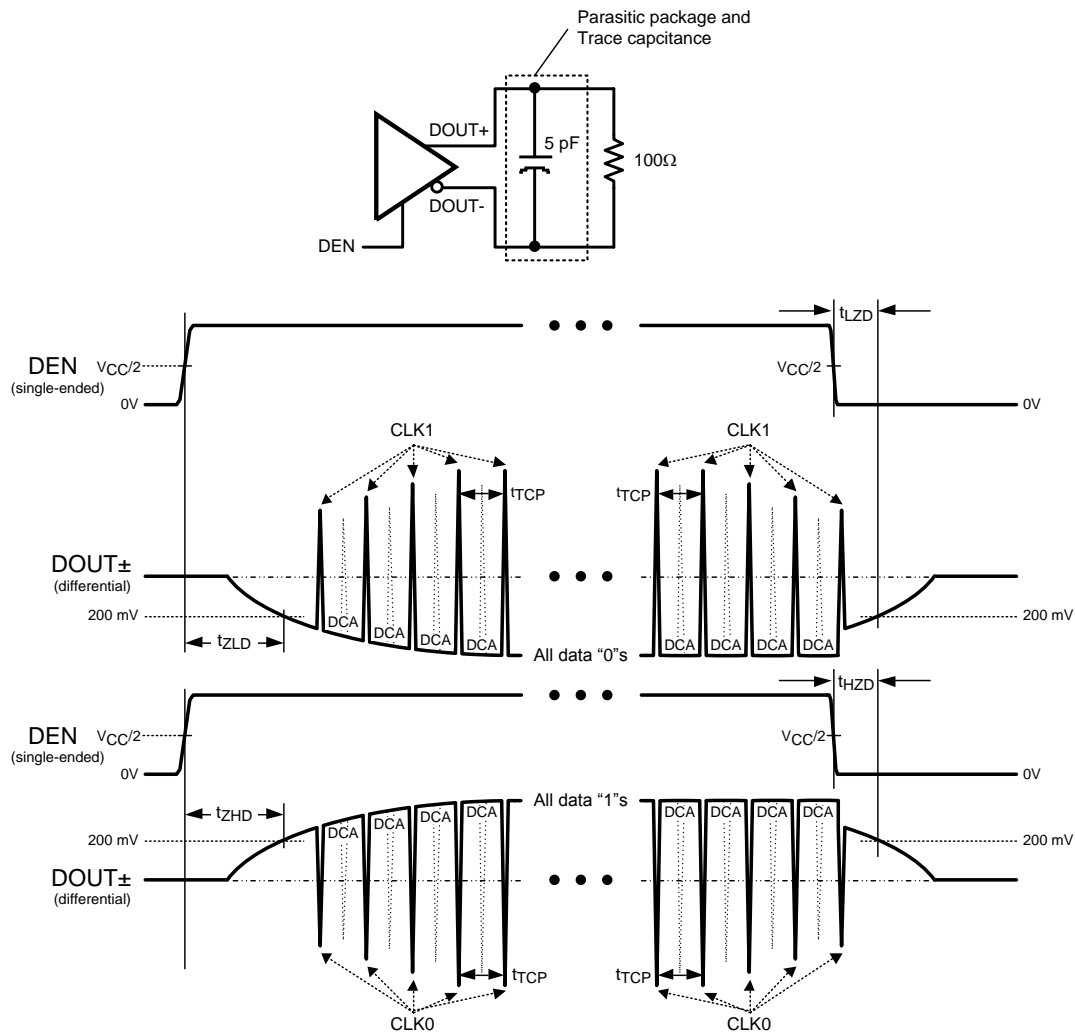

Figure 6. Serializer TRI-STATE Test Circuit and Delay

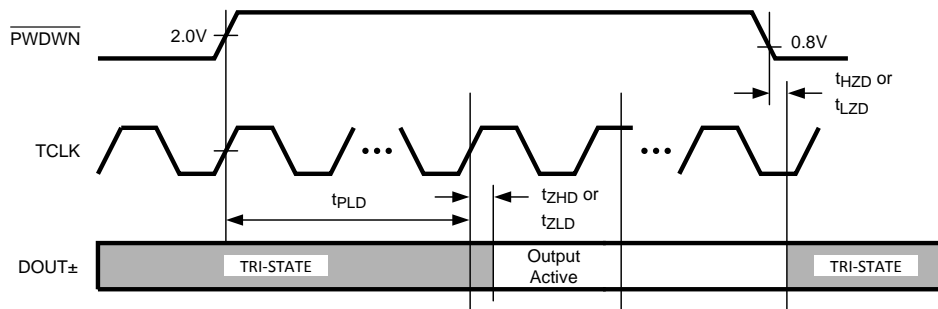

Figure 7. Serializer PLL Lock Time, and TPWDNB TRI-STATE Delays

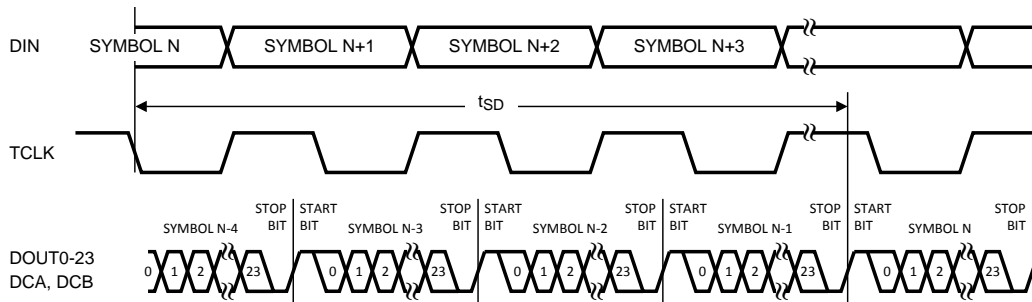

Figure 8. Serializer Delay

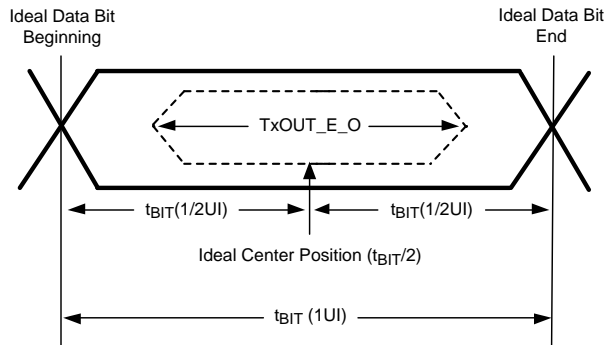
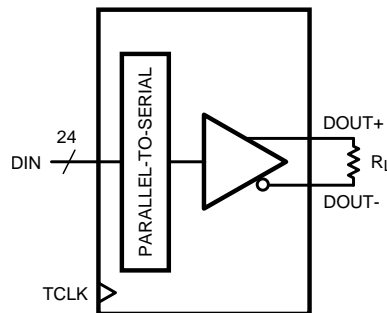

Figure 9. Transmitter Output Eye Opening (TxOUT_E_O)



$$VOD = (D_{OUT+}) - (D_{OUT-})$$

Differential output signal is shown as $(D_{OUT+}) - (D_{OUT-})$, device in Data Transfer mode.

Figure 10. Serializer VOD Diagram

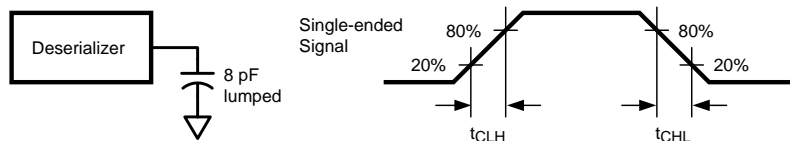

Figure 11. Deserializer LVCMOS/LVTTL Output Load and Transition Times

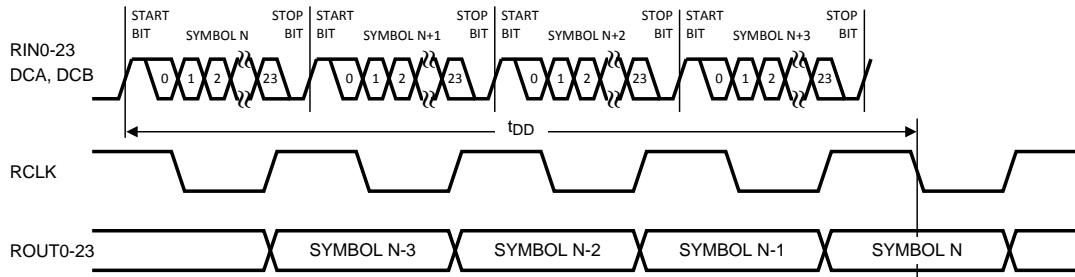
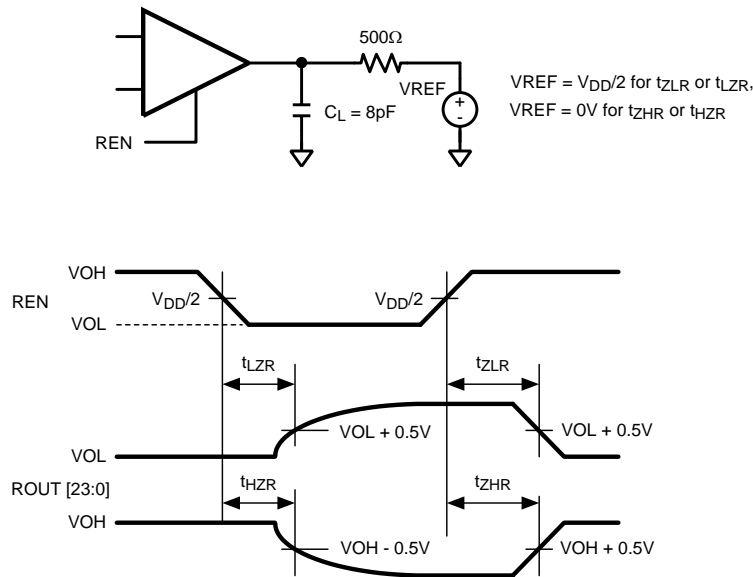

Figure 12. Deserializer Delay



Note: C_L includes instrumentation and fixture capacitance within 6 cm of ROUT[23:0]

Figure 13. Deserializer TRI-STATE Test Circuit and Timing

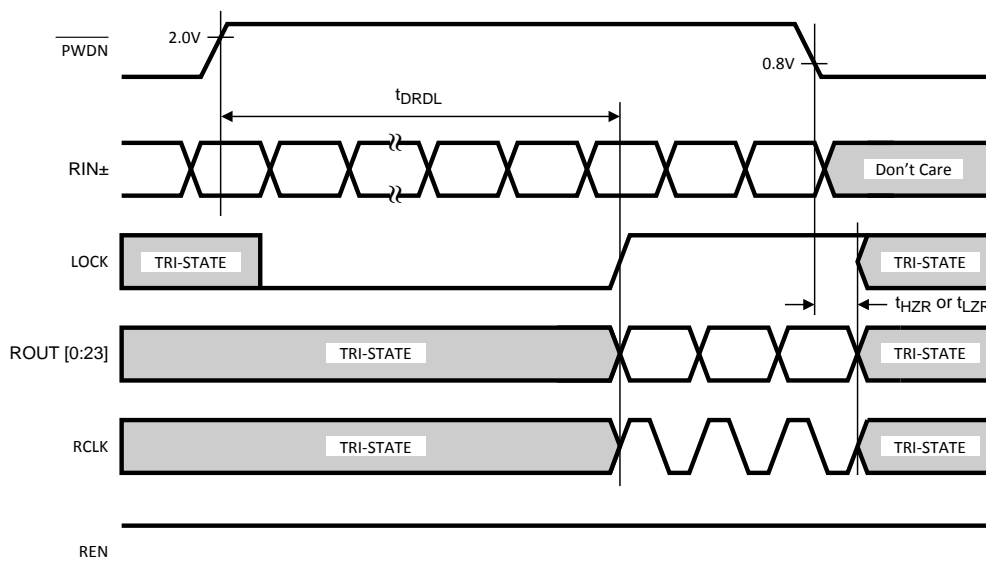

Figure 14. Deserializer PLL Lock Times and RPWDNB TRI-STATE Delay

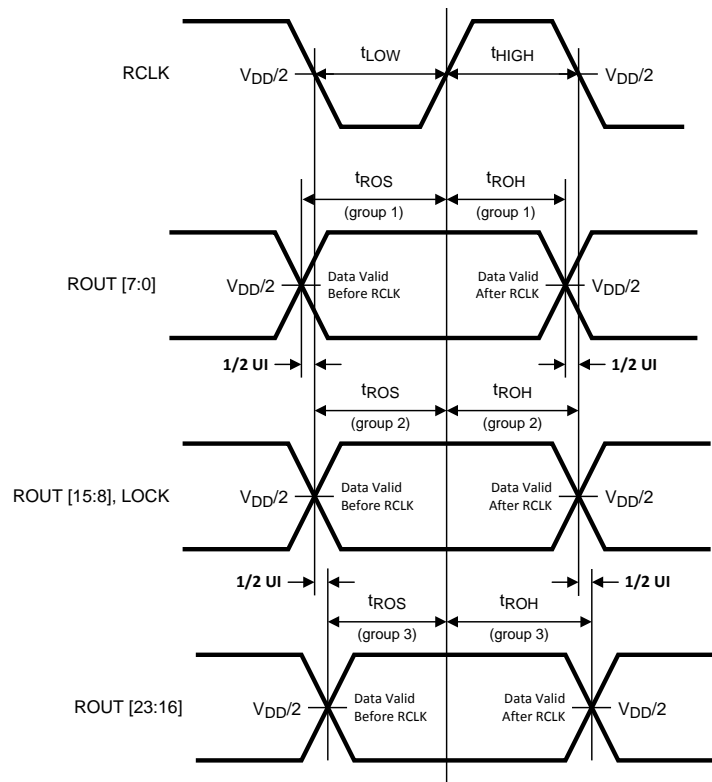
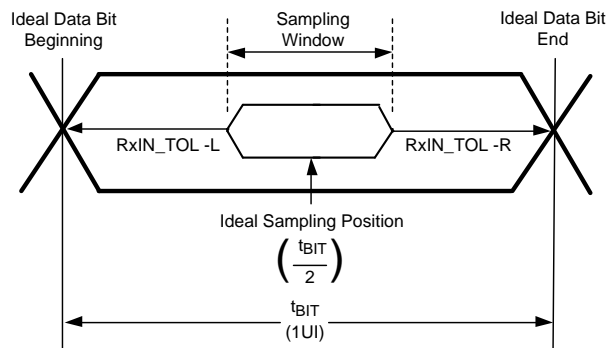

Figure 15. Deserializer Setup and Hold Times



RxIN_TOL_L is the ideal noise margin on the left of the figure, with respect to ideal.
RxIN_TOL_R is the ideal noise margin on the right of the figure, with respect to ideal.

Figure 16. Receiver Input Tolerance (RxIN_TOL) and Sampling Window

DS99R103 Pin Diagram

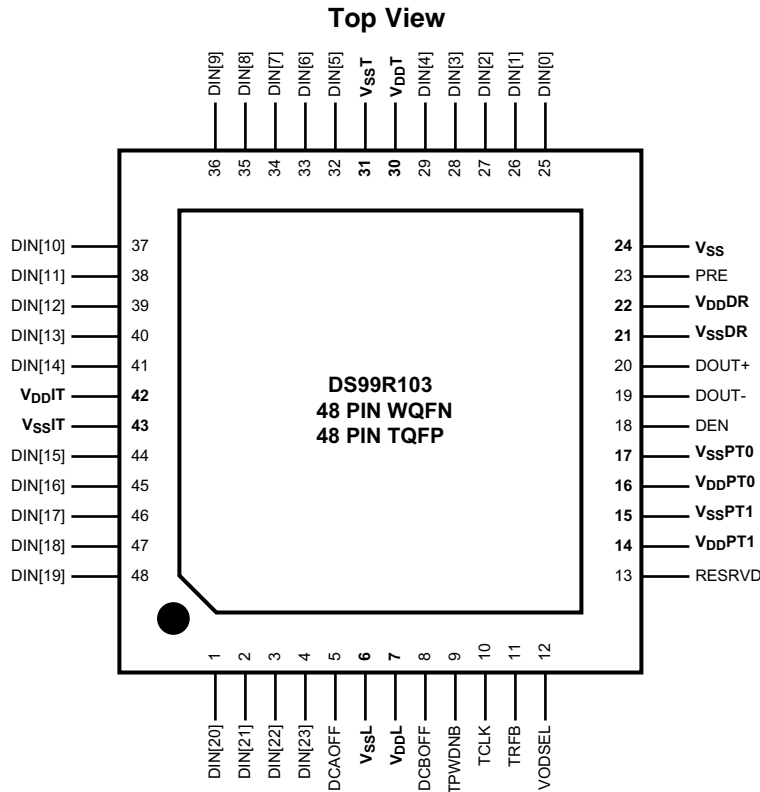

Figure 17. Serializer - DS99R103
See Package Numbers NJU0048D (WQFN) and PFB0048A (TQFP)

DS99R103 Serializer Pin Descriptions

Pin No.	Pin Name	I/O	Description
LVC MOS PARALLEL INTERFACE PINS			
4-1, 48-44, 41-32, 29-25	DIN[23:0]	LVC MOS_I	Transmitter Parallel Interface Data Inputs Pins. Tie LOW if unused, do not float.
10	TCLK	LVC MOS_I	Transmitter Parallel Interface Clock Input Pin. Strobe edge set by TRFB configuration pin
CONTROL AND CONFIGURATION PINS			
9	TPWDNB	LVC MOS_I	Transmitter Power Down Bar TPWDNB = H; Transmitter is Enabled and ON TPWDNB = L; Transmitter is in power down mode (Sleep), LVDS Driver DOUT (+/-) Outputs are in TRI-STATE stand-by mode, PLL is shutdown to minimize power consumption.
18	DEN	LVC MOS_I	Transmitter Data Enable DEN = H; LVDS Driver Outputs are Enabled (ON). DEN = L; LVDS Driver Outputs are Disabled (OFF), Transmitter LVDS Driver DOUT (+/-) Outputs are in TRI-STATE, PLL still operational and locked to TCLK.
23	PRE	LVC MOS_I	PRE -emphasis select pin. PRE = (R _{PRE} ≥ 3 kΩ); I _{max} = [(1.2/R)*20], R _{min} = 3 kΩ PRE = No Connect (NC); pre-emphasis is disabled
11	TRFB	LVC MOS_I	Transmitter Clock Edge Select Pin TRFB = H; Parallel Interface Data is strobed on the Rising Clock Edge. TRFB = L; Parallel Interface Data is strobed on the Falling Clock Edge

DS99R103 Serializer Pin Descriptions (continued)

Pin No.	Pin Name	I/O	Description
12	VODSEL	LVC MOS_I	VOD Level Select VODSEL = L; LVDS Driver Output is $\approx \pm 400$ mV ($R_L = 100\Omega$) VODSEL = H; LVDS Driver Output is $\approx \pm 750$ mV ($R_L = 100\Omega$) For normal applications, set this pin LOW. For long cable applications where a larger VOD is required, set this pin HIGH.
5	DCAOFF	LVC MOS_I	RESERVED – This pin MUST be tied LOW.
8	DCBOFF	LVC MOS_I	RESERVED – This pin MUST be tied LOW.
13	RESRVD	LVC MOS_I	RESERVED – This pin MUST be tied LOW.
LVDS SERIAL INTERFACE PINS			
20	DOU T+	LVDS_O	Transmitter LVDS True (+) Output. This output is intended to be loaded with a 100 Ω load to the DOU T+ pin. The interconnect should be AC Coupled to this pin with a 100 nF capacitor.
19	DOU T-	LVDS_O	Transmitter LVDS Inverted (-) Output This output is intended to be loaded with a 100 Ω load to the DOU T- pin. The interconnect should be AC Coupled to this pin with a 100 nF capacitor.
POWER / GROUND PINS			
22	VDDDR	VDD	Analog Voltage Supply, LVDS Output Power
21	VSSDR	GND	Analog Ground, LVDS Output Ground
16	VDDPT0	VDD	Analog Voltage supply, VCO Power
17	VSSPT0	GND	Analog Ground, VCO Ground
14	VDDPT1	VDD	Analog Voltage supply, PLL Power
15	VSSPT1	GND	Analog Ground, PLL Ground
30	VDDT	VDD	Digital Voltage supply, Tx Serializer Power
31	VSST	GND	Digital Ground, Tx Serializer Ground
7	VDDL	VDD	Digital Voltage supply, Tx Logic Power
6	VSSL	GND	Digital Ground, Tx Logic Ground
42	VDDIT	VDD	Digital Voltage supply, Tx Input Power
43	VSSIT	GND	Digital Ground, Tx Input Ground
24	VSS	GND	ESD Ground

DS99R104 Pin Diagram

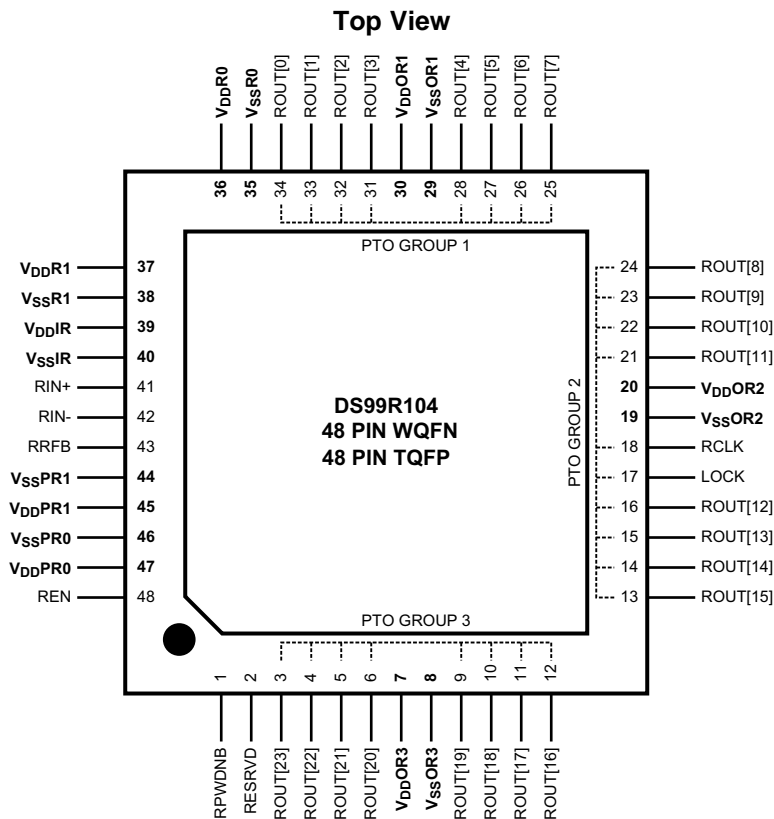

Figure 18. Deserializer - DS99R104
See Package Numbers NJU0048D (WQFN) and PFB0048A (TQFP)

DS99R104 Deserializer Pin Descriptions

Pin No.	Pin Name	I/O	Description
LVC MOS PARALLEL INTERFACE PINS			
25-28, 31-34	ROUT[7:0]	LVC MOS_O	Receiver Parallel Interface Data Outputs – Group 1
13-16, 21-24	ROUT[15:8]	LVC MOS_O	Receiver Parallel Interface Data Outputs – Group 2
3-6, 9-12	ROUT[23:16]	LVC MOS_O	Receiver Parallel Interface Data Outputs – Group 3
18	RCLK	LVC MOS_O	Parallel Interface Clock Output Pin. Strobe edge set by RRF B configuration pin.
CONTROL AND CONFIGURATION PINS			
43	RRFB	LVC MOS_I	Receiver Clock Edge Select Pin RRFB = H; ROUT LVC MOS Outputs strobed on the Rising Clock Edge. RRFB = L; ROUT LVC MOS Outputs strobed on the Falling Clock Edge.
48	REN	LVC MOS_I	Receiver Data Enable REN = H; ROUT[23-0] and RCLK are Enabled (ON). REN = L; ROUT[23-0] and RCLK are Disabled (OFF), Receiver ROUT[23-0] and RCLK Outputs are in TRI-STATE, PLL still operational and locked to TCLK.
1	RPWDNB	LVC MOS_I	Receiver Data Enable REN = H; ROUT[23-0] and RCLK are Enabled (ON). REN = L; ROUT[23-0] and RCLK are Disabled (OFF), Receiver ROUT[23-0] and RCLK Outputs are in TRI-STATE, PLL still operational and locked to TCLK.

DS99R104 Deserializer Pin Descriptions (continued)

Pin No.	Pin Name	I/O	Description
17	LOCK	LVC MOS_O	LOCK indicates the status of the receiver PLL LOCK = H; receiver PLL is locked LOCK = L; receiver PLL is unlocked, ROUT[23-0] and RCLK are TRI-STATED
2	RESRVD	LVC MOS_I	RESERVED – This pin MUST be tied LOW.
LVDS SERIAL INTERFACE PINS			
41	RIN+	LVDS_I	Receiver LVDS True (+) Input This input is intended to be terminated with a 100Ω load to the RIN+ pin. The interconnect should be AC Coupled to this pin with a 100 nF capacitor.
42	RIN-	LVDS_I	Receiver LVDS Inverted (-) Input This input is intended to be terminated with a 100Ω load to the RIN- pin. The interconnect should be AC Coupled to this pin with a 100 nF capacitor.
POWER / GROUND PINS			
39	VDDIR	VDD	Analog LVDS Voltage supply, Power
40	VSSIR	GND	Analog LVDS Ground
47	VDDPR0	VDD	Analog Voltage supply, PLL Power
46	VSSPR0	GND	Analog Ground, PLL Ground
45	VDDPR1	VDD	Analog Voltage supply, PLL VCO Power
44	VSSPR1	GND	Analog Ground, PLL VCO Ground
37	VDDR1	VDD	Digital Voltage supply, Logic Power
38	VSSR1	GND	Digital Ground, Logic Ground
36	VDDR0	VDD	Digital Voltage supply, Logic Power
35	VSSR0	GND	Digital Ground, Logic Ground
30	VDDOR1	VDD	Digital Voltage supply, LVC MOS Output Power
29	VSSOR1	GND	Digital Ground, LVC MOS Output Ground
20	VDDOR2	VDD	Digital Voltage supply, LVC MOS Output Power
19	VSSOR2	GND	Digital Ground, LVC MOS Output Ground
7	VDDOR3	VDD	Digital Voltage supply, LVC MOS Output Power
8	VSSOR3	GND	Digital Ground, LVC MOS Output Ground

FUNCTIONAL DESCRIPTION

The DS99R103 Serializer and DS99R104 Deserializer chipset is an easy-to-use transmitter and receiver pair that sends 24-bits of parallel LVC MOS data over a single serial LVDS link from 72 Mbps to 960 Mbps throughput. The DS99R103 transforms a 24-bit wide parallel LVC MOS data into a single high speed LVDS serial data stream with embedded clock. The DS99R104 receives the LVDS serial data stream and converts it back into a 24-bit wide parallel data and recovered clock. The 24-bit Serializer/Deserializer chipset is designed to transmit data over shielded twisted pair (STP) at clock speeds from 3 MHz to 40 MHz.

The Deserializer can attain lock to a data stream without the use of a separate reference clock source. The Deserializer synchronizes to the Serializer regardless of data pattern, delivering true automatic “plug and lock” performance. The Deserializer recovers the clock and data by extracting the embedded clock information and validating data integrity from the incoming data stream and then deserializes the data. The Deserializer monitors the incoming clock information, determines lock status, and asserts the LOCK output high when lock occurs. Each has a power down control to enable efficient operation in various applications.

INITIALIZATION AND LOCKING MECHANISM

Initialization of the DS99R103 and DS99R104 must be established before each device sends or receives data. Initialization refers to synchronizing the Serializer’s and Deserializer’s PLL’s together. After the Serializers locks to the input clock source, the Deserializer synchronizes to the Serializers as the second and final initialization step.

1. When V_{DD} is applied to both Serializer and/or Deserializer, the respective outputs are held in TRI-STATE and internal circuitry is disabled by on-chip power-on circuitry. When V_{DD} reaches V_{DD} OK (2.2V) the PLL in Serializer begins locking to a clock input. For the Serializer, the local clock is the transmit clock, TCLK. The Serializer outputs are held in TRI-STATE while the PLL locks to the TCLK. After locking to TCLK, the

Serializer block is now ready to send data patterns. The Deserializer output will remain in TRI-STATE while its PLL locks to the embedded clock information in serial data stream. Also, the Deserializer LOCK output will remain low until its PLL locks to incoming data and sync-pattern on the RIN± pins.

2. The Deserializer PLL acquires lock to a data stream without requiring the Serializer to send special patterns. The Serializer that is generating the stream to the Deserializer will automatically send random (non-repetitive) data patterns during this step of the Initialization State. The Deserializer will lock onto embedded clock within the specified amount of time. An embedded clock and data recovery (CDR) circuit locks to the incoming bit stream to recover the high-speed receive bit clock and re-time incoming data. The CDR circuit expects a coded input bit stream. In order for the Deserializer to lock to a random data stream from the Serializer, it performs a series of operations to identify the rising clock edge and validates data integrity, then locks to it. Because this locking procedure is independent on the data pattern, total random locking duration may vary. At the point when the Deserializer's CDR locks to the embedded clock, the LOCK pin goes high and valid RCLK/data appears on the outputs. Note that the LOCK signal is synchronous to valid data appearing on the outputs. The Deserializer's LOCK pin is a convenient way to ensure data integrity is achieved on receiver side.

DATA TRANSFER

After lock is established, the Serializer inputs DIN0–DIN23 are used to input data to the Serializer. Data is clocked into the Serializer by the TCLK input. The edge of TCLK used to strobe the data is selectable via the TRFB pin. TRFB high selects the rising edge for clocking data and low selects the falling edge. The Serializer outputs (DOUT±) are intended to drive point-to-point connections or limited multi-point applications.

CLK1, CLK0, DCA, DCB are four overhead bits transmitted along the single LVDS serial data stream. The CLK1 bit is always high and the CLK0 bit is always low. The CLK1 and CLK0 bits function as the embedded clock bits in the serial stream. DCB functions as the DC Balance control bit. It does not require any pre-coding of data on transmit side. The DC Balance bit is used to minimize the short and long-term DC bias on the signal lines. This bit operates by selectively sending the data either unmodified or inverted. The DCA bit is used to validate data integrity in the embedded data stream. Both DCA and DCB coding schemes are integrated and automatically performed within Serializer and Deserializer.

The chipset supports clock frequency ranges of 3 MHz to 40 MHz. Every clock cycle, 24 databits are sent along with 4 additional overhead control bits. Thus the line rate is 1.12 Gbps maximum (84 Mbps minimum). The link is extremely efficient at 86% (24/28). Twenty five (24 data + 1 clock) plus associated ground signals are reduced to only 1 single LVDS pair providing a compression ratio of better than 25 to 1.

Serialized data and clock/control bits (24+4 bits) are transmitted from the serial data output (DOUT±) at 28 times the TCLK frequency. For example, if TCLK is 40 MHz, the serial rate is $40 \times 28 = 1.12$ Giga bits per second. Since only 24 bits are from input data, the serial "payload" rate is 24 times the TCLK frequency. For instance, if TCLK = 40 MHz, the payload data rate is $40 \times 24 = 960$ Mbps. TCLK is provided by the data source and must be in the range of 3 MHz to 40 MHz nominal. The Serializer outputs (DOUT±) can drive a point-to-point connection as shown in [Figure 19](#). The outputs transmit data when the enable pin (DEN) is high and TPWDNB is high. The DEN pin may be used to TRI-STATE the outputs when driven low.

When the Deserializer channel attains lock to the input from a Serializer, it drives its LOCK pin high and synchronously delivers valid data and recovered clock on the output. The Deserializer locks onto the embedded clock, uses it to generate multiple internal data strobes, and then drives the recovered clock to the RCLK pin. The recovered clock (RCLK output pin) is synchronous to the data on the ROUT[23:0] pins. While LOCK is high, data on ROUT[23:0] is valid. Otherwise, ROUT[23:0] is invalid. The polarity of the RCLK edge is controlled by the RRFb input. ROUT(0-23), LOCK and RCLK outputs will each drive a maximum of 8 pF load with a 40 MHz clock. REN controls TRI-STATE for ROUTn and the RCLK pin on the Deserializer.

RESYNCHRONIZATION

If the Deserializer loses lock, it will automatically try to re-establish lock. For example, if the embedded clock edge is not detected one time in succession, the PLL loses lock and the LOCK pin is driven low. The Deserializer then enters the operating mode where it tries to lock to a random data stream. It looks for the embedded clock edge, identifies it and then proceeds through the locking process.

The logic state of the LOCK signal indicates whether the data on ROUT is valid; when it is high, the data is valid. The system must monitor the LOCK pin to determine whether data on the ROUT is valid.

POWERDOWN

The Powerdown state is a low power sleep mode that the Serializer and Deserializer may use to reduce power when no data is being transferred. The TPWDNB and RPWDNB are used to set each device into power down mode, which reduces supply current to the μA range. The Serializer enters powerdown when the TPWDNB pin is driven low. In powerdown, the PLL stops and the outputs go into TRI-STATE, disabling load current and reducing supply. To exit Powerdown, TPWDNB must be driven high. When the Serializer exits Powerdown, its PLL must lock to TCLK before it is ready for the Initialization state. The system must then allow time for Initialization before data transfer can begin. The Deserializer enters powerdown mode when RPWDNB is driven low. In powerdown mode, the PLL stops and the outputs enter TRI-STATE. To bring the Deserializer block out of the powerdown state, the system drives RPWDNB high.

Both the Serializer and Deserializer must reinitialize and relock before data can be transferred. The Deserializer will initialize and assert LOCK high when it is locked to the encoded clock.

TRI-STATE

For the Serializer, TRI-STATE is entered when the DEN or TPWDNB pin is driven low. This will TRI-STATE both driver output pins (DOUT+ and DOUT-). When DEN is driven high, the serializer will return to the previous state as long as all other control pins remain static (TPWDNB, TRFB).

When you drive the REN or RPWDNB pin low, the Deserializer enters TRI-STATE. Consequently, the receiver output pins (ROUT0–ROUT23) and RCLK will enter TRI-STATE. The LOCK output remains active, reflecting the state of the PLL. The Deserializer input pins are high impedance during receiver powerdown (RPWDNB low) and power-off ($V_{\text{DD}} = 0\text{V}$).

PRE-EMPHASIS

The DS99R103 features a Pre-Emphasis mode used to compensate for long or lossy transmission media. Cable drive is enhanced with a user selectable Pre-Emphasis feature that provides additional output current during transitions to counteract cable loading effects. The transmission distance will be limited by the loss characteristics and quality of the media. Pre-Emphasis adds extra current during LVDS logic transition to reduce the cable loading effects and increase driving distance. In addition, Pre-Emphasis helps provide faster transitions, increased eye openings, and improved signal integrity. To enable the Pre-Emphasis function, the "PRE" pin requires one external resistor (R_{pre}) to Vss in order to set the additional current level. Pre-Emphasis strength is set via an external resistor (R_{pre}) applied from min to max (floating to $3\text{k}\Omega$) at the "PRE" pin. A lower input resistor value on the "PRE" pin increases the magnitude of dynamic current during data transition. There is an internal current source based on the following formula: $\text{PRE} = (R_{\text{pre}} \geq 3\text{k}\Omega); \text{IMAX} = [(1.2/R_{\text{pre}}) \times 20]$. The ability of the DS99R103 to use the Pre-Emphasis feature will extend the transmission distance in most cases.

The amount of Pre-Emphasis for a given media will depend on the transmission distance of the application. In general, too much Pre-Emphasis can cause over or undershoot at the receiver input pins. This can result in excessive noise, crosstalk and increased power dissipation. For short cables or distances, Pre-Emphasis may not be required. Signal quality measurements are recommended to determine the proper amount of Pre-Emphasis for each application.

AC-COUPLING AND TERMINATION

The DS99R103 and DS99R104 supports AC-coupled interconnects through integrated DC balanced encoding/decoding scheme. To use AC coupled connection between the Serializer and Deserializer, insert external AC coupling capacitors in series in the LVDS signal path as illustrated in [Figure 19](#). The Deserializer input stage is designed for AC-coupling by providing a built-in AC bias network which sets the internal V_{CM} to +1.2V. With AC signal coupling, capacitors provide the ac-coupling path to the signal input.

For the high-speed LVDS transmissions, the smallest available package should be used for the AC coupling capacitor. This will help minimize degradation of signal quality due to package parasitics. The most common used capacitor value for the interface is 100 nF (0.1 μF) capacitor.

A termination resistor across DOUT \pm is also required for proper operation to be obtained. The termination resistor should be equal to the differential impedance of the media being driven. This should be in the range of 90 to 132 Ω . 100 Ω is a typical value common used with standard 100 Ω transmission media. This resistor is required for control of reflections and also to complete the current loop. It should be placed as close to the Serializer DOUT \pm outputs to minimize the stub length from the pins. To match with the differential impedance on the transmission line, the LVDS I/O are terminated with 100 Ω resistors on Serializer DOUT \pm outputs pins.

PROGRESSIVE TURN-ON (PTO)

Deserializer ROUT[23:0] outputs are grouped into three groups of eight, with each group switching about 0.5UI apart in phase to reduce EMI, simultaneous switching noise, and system ground bounce.

Applications Information

USING THE DS99R103 AND DS99R104

The DS99R103/DS99R104 Serializer/Deserializer (SERDES) pair sends 24 bits of parallel LVCMOS data over a serial LVDS link up to 960 Mbps. Serialization of the input data is accomplished using an on-board PLL at the Serializer which embeds clock with the data. The Deserializer extracts the clock/control information from the incoming data stream and deserializes the data. The Deserializer monitors the incoming clock information to determine lock status and will indicate lock by asserting the LOCK output high.

POWER CONSIDERATIONS

An all CMOS design of the Serializer and Deserializer makes them inherently low power devices. Additionally, the constant current source nature of the LVDS outputs minimize the slope of the speed vs. I_{DD} curve of CMOS designs.

NOISE MARGIN

The Deserializer noise margin is the amount of input jitter (phase noise) that the Deserializer can tolerate and still reliably recover data. Various environmental and systematic factors include:

- Serializer: TCLK jitter, V_{DD} noise (noise bandwidth and out-of-band noise)
- Media: ISI, V_{CM} noise
- Deserializer: V_{DD} noise

For a graphical representation of noise margin, please see [Figure 16](#).

TRANSMISSION MEDIA

The Serializer and Deserializer can be used in point-to-point configuration, through a PCB trace, or through twisted pair cable. In a point-to-point configuration, the transmission media needs be terminated at both ends of the transmitter and receiver pair. Interconnect for LVDS typically has a differential impedance of 100 Ω . Use cables and connectors that have matched differential impedance to minimize impedance discontinuities. In most applications that involve cables, the transmission distance will be determined on data rates involved, acceptable bit error rate and transmission medium.

LIVE LINK INSERTION

The Serializer and Deserializer devices support live pluggable applications. The “Hot Inserted” operation on the serial interface does not disrupt communication data on the active data lines. The automatic receiver lock to random data “plug & go” live insertion capability allows the DS99R104 to attain lock to the active data stream during a live insertion event.

PCB LAYOUT AND POWER SYSTEM CONSIDERATIONS

Circuit board layout and stack-up for the LVDS SERDES devices should be designed to provide low-noise power feed to the device. Good layout practice will also separate high frequency or high-level inputs and outputs to minimize unwanted stray noise pickup, feedback and interference. Power system performance may be greatly improved by using thin dielectrics (2 to 4 mils) for power / ground sandwiches. This arrangement provides plane capacitance for the PCB power system with low-inductance parasitics, which has proven especially effective at high frequencies, and makes the value and placement of external bypass capacitors less critical. External bypass capacitors should include both RF ceramic and tantalum electrolytic types. RF capacitors may use values in the range of 0.01 μF to 0.1 μF . Tantalum capacitors may be in the 2.2 μF to 10 μF range. Voltage rating of the tantalum capacitors should be at least 5X the power supply voltage being used.

Surface mount capacitors are recommended due to their smaller parasitics. When using multiple capacitors per supply pin, locate the smaller value closer to the pin. A large bulk capacitor is recommended at the point of power entry. This is typically in the 50 μF to 100 μF range and will smooth low frequency switching noise. It is recommended to connect power and ground pins directly to the power and ground planes with bypass capacitors connected to the plane with via on both ends of the capacitor. Connecting power or ground pins to an external bypass capacitor will increase the inductance of the path.

A small body size X7R chip capacitor, such as 0603, is recommended for external bypass. Its small body size reduces the parasitic inductance of the capacitor. The user must pay attention to the resonance frequency of these external bypass capacitors, usually in the range of 20-30 MHz range. To provide effective bypassing, multiple capacitors are often used to achieve low impedance between the supply rails over the frequency of interest. At high frequency, it is also a common practice to use two vias from power and ground pins to the planes, reducing the impedance at high frequency.

Some devices provide separate power and ground pins for different portions of the circuit. This is done to isolate switching noise effects between different sections of the circuit. Separate planes on the PCB are typically not required. Pin Description tables typically provide guidance on which circuit blocks are connected to which power pin pairs. In some cases, an external filter may be used to provide clean power to sensitive circuits such as PLLs.

Use at least a four layer board with a power and ground plane. Locate LVCMOS (LVTTTL) signals away from the LVDS lines to prevent coupling from the LVCMOS lines to the LVDS lines. Closely-coupled differential lines of 100 Ω are typically recommended for LVDS interconnect. The closely coupled lines help to ensure that coupled noise will appear as common-mode and thus is rejected by the receivers. The tightly coupled lines will also radiate less.

Termination of the LVDS interconnect is required. For point-to-point applications, termination should be located at both ends of the devices. Nominal value is 100 Ω to match the line's differential impedance. Place the resistor as close to the transmitter DOUT \pm outputs and receiver RIN \pm inputs as possible to minimize the resulting stub between the termination resistor and device.

LVDS INTERCONNECT GUIDELINES

See AN-1108 (Literature Number [SNLA008](#)) and AN-905 (Literature Number [SNLA035](#)) for full details.

- Use 100 Ω coupled differential pairs
- Use the S/2S/3S rule in spacings
 - S = space between the pair
 - 2S = space between pairs
 - 3S = space to LVCMOS/LVTTTL signal
- Minimize the number of VIA
- Use differential connectors when operating above 500Mbps line speed
- Maintain balance of the traces
- Minimize skew within the pair
- Terminate as close to the TX outputs and RX inputs as possible

Additional general guidance can be found in the LVDS Owner's Manual - available in PDF format from the TI web site at: <http://www.ti.com/ww/en/analog/interface/lvds.shtml>

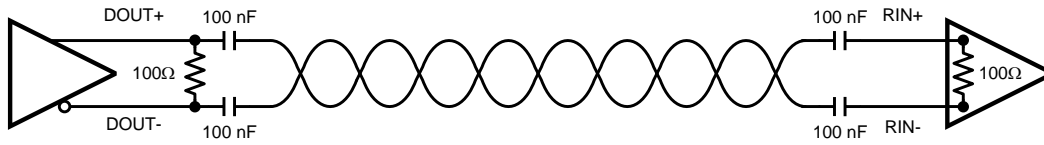

Figure 19. AC Coupled Application

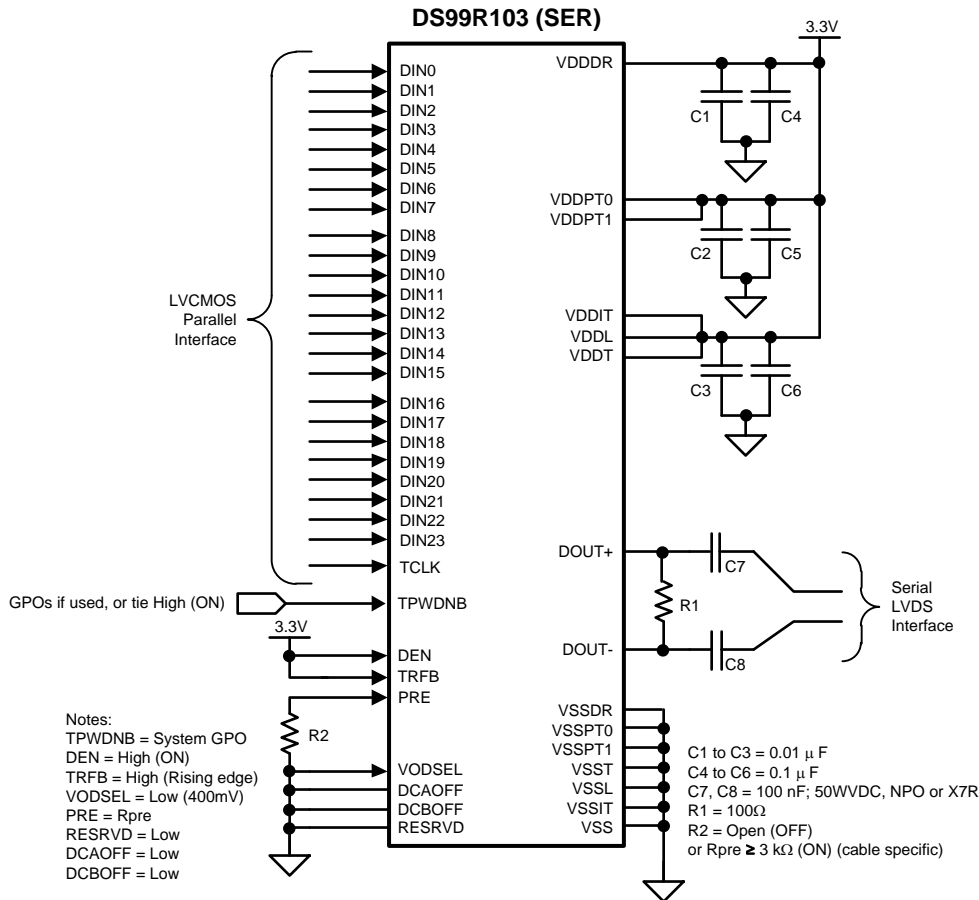

Figure 20. DS99R103 Typical Application Connection

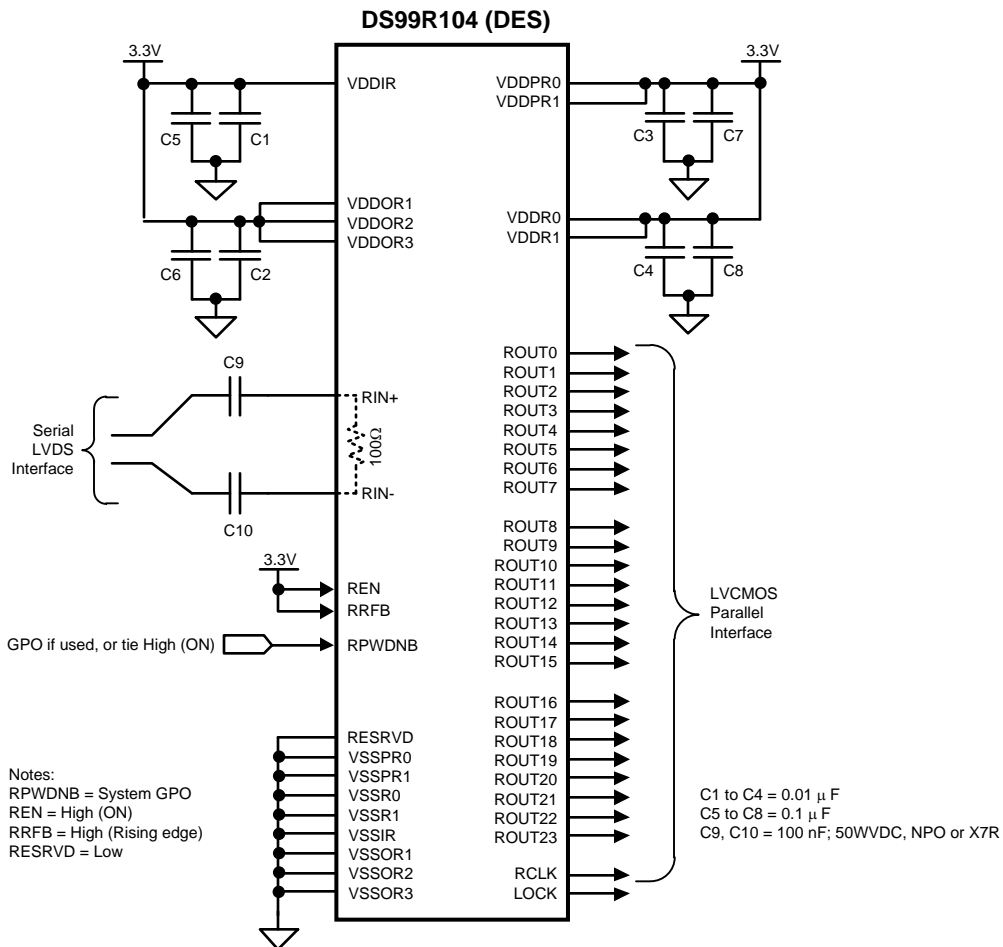

Figure 21. DS99R104 Typical Application Connection

TRUTH TABLES

DS99R103 Serializer Truth Table

TPWdNB (Pin 9)	DEN (Pin 18)	Tx PLL Status (Internal)	LVDS Outputs (Pins 19 and 20)
L	X	X	Hi Z
H	L	X	Hi Z
H	H	Not Locked	Hi Z
H	H	Locked	Serialized Data with Embedded Clock

DS99R104 Deserializer Truth Table

RPWdNB (Pin 1)	REN (Pin 48)	Rx PLL Status (Internal)	ROUTn and RCLK (See DS99R104 Pin Diagram)	LOCK (Pin 17)
L	X	X	Hi Z	Hi Z
H	L	X	Hi Z	L = PLL Unocked; H = PLL Locked
H	H	Not Locked	Hi Z	L
H	H	Locked	Data and RCLK Active	H

REVISION HISTORY

Changes from Revision C (April 2013) to Revision D	Page
• Changed layout of National Data Sheet to TI format	21

PACKAGING INFORMATION

Orderable Device	Status (1)	Package Type	Package Drawing	Pins	Package Qty	Eco Plan (2)	Lead/Ball Finish (6)	MSL Peak Temp (3)	Op Temp (°C)	Device Marking (4/5)	Samples
DS99R103TSQ/NOPB	ACTIVE	WQFN	NJU	48	250	Green (RoHS & no Sb/Br)	CU SN	Level-2-260C-1 YEAR		DS99R103T	Samples
DS99R103TSQX/NOPB	ACTIVE	WQFN	NJU	48	2500	Green (RoHS & no Sb/Br)	CU SN	Level-2-260C-1 YEAR	-40 to 85	DS99R103T	Samples
DS99R103TVS/NOPB	ACTIVE	TQFP	PFB	48	250	Green (RoHS & no Sb/Br)	CU SN	Level-3-260C-168 HR		DS99R103 TVS	Samples
DS99R104TSQ/NOPB	ACTIVE	WQFN	NJU	48	250	Green (RoHS & no Sb/Br)	CU SN	Level-2-260C-1 YEAR		DS99R104T	Samples
DS99R104TSQX/NOPB	ACTIVE	WQFN	NJU	48	2500	Green (RoHS & no Sb/Br)	CU SN	Level-2-260C-1 YEAR	-40 to 85	DS99R104T	Samples
DS99R104TVS/NOPB	ACTIVE	TQFP	PFB	48	250	Green (RoHS & no Sb/Br)	CU SN	Level-3-260C-168 HR	-40 to 85	DS99R104 TVS	Samples

(1) The marketing status values are defined as follows:

ACTIVE: Product device recommended for new designs.

LIFEBUY: TI has announced that the device will be discontinued, and a lifetime-buy period is in effect.

NRND: Not recommended for new designs. Device is in production to support existing customers, but TI does not recommend using this part in a new design.

PREVIEW: Device has been announced but is not in production. Samples may or may not be available.

OBSOLETE: TI has discontinued the production of the device.

(2) **RoHS:** TI defines "RoHS" to mean semiconductor products that are compliant with the current EU RoHS requirements for all 10 RoHS substances, including the requirement that RoHS substance do not exceed 0.1% by weight in homogeneous materials. Where designed to be soldered at high temperatures, "RoHS" products are suitable for use in specified lead-free processes. TI may reference these types of products as "Pb-Free".

RoHS Exempt: TI defines "RoHS Exempt" to mean products that contain lead but are compliant with EU RoHS pursuant to a specific EU RoHS exemption.

Green: TI defines "Green" to mean the content of Chlorine (Cl) and Bromine (Br) based flame retardants meet JS709B low halogen requirements of <=1000ppm threshold. Antimony trioxide based flame retardants must also meet the <=1000ppm threshold requirement.

(3) MSL, Peak Temp. - The Moisture Sensitivity Level rating according to the JEDEC industry standard classifications, and peak solder temperature.

(4) There may be additional marking, which relates to the logo, the lot trace code information, or the environmental category on the device.

(5) Multiple Device Markings will be inside parentheses. Only one Device Marking contained in parentheses and separated by a "~" will appear on a device. If a line is indented then it is a continuation of the previous line and the two combined represent the entire Device Marking for that device.

⁽⁶⁾ Lead/Ball Finish - Orderable Devices may have multiple material finish options. Finish options are separated by a vertical ruled line. Lead/Ball Finish values may wrap to two lines if the finish value exceeds the maximum column width.

Important Information and Disclaimer:The information provided on this page represents TI's knowledge and belief as of the date that it is provided. TI bases its knowledge and belief on information provided by third parties, and makes no representation or warranty as to the accuracy of such information. Efforts are underway to better integrate information from third parties. TI has taken and continues to take reasonable steps to provide representative and accurate information but may not have conducted destructive testing or chemical analysis on incoming materials and chemicals. TI and TI suppliers consider certain information to be proprietary, and thus CAS numbers and other limited information may not be available for release.

In no event shall TI's liability arising out of such information exceed the total purchase price of the TI part(s) at issue in this document sold by TI to Customer on an annual basis.

TAPE AND REEL INFORMATION

QUADRANT ASSIGNMENTS FOR PIN 1 ORIENTATION IN TAPE

*All dimensions are nominal

Device	Package Type	Package Drawing	Pins	SPQ	Reel Diameter (mm)	Reel Width W1 (mm)	A0 (mm)	B0 (mm)	K0 (mm)	P1 (mm)	W (mm)	Pin1 Quadrant
DS99R103TSQ/NOPB	WQFN	NJU	48	250	178.0	16.4	7.3	7.3	1.3	12.0	16.0	Q1
DS99R103TSQX/NOPB	WQFN	NJU	48	2500	330.0	16.4	7.3	7.3	1.3	12.0	16.0	Q1
DS99R104TSQ/NOPB	WQFN	NJU	48	250	178.0	16.4	7.3	7.3	1.3	12.0	16.0	Q1
DS99R104TSQX/NOPB	WQFN	NJU	48	2500	330.0	16.4	7.3	7.3	1.3	12.0	16.0	Q1

TAPE AND REEL BOX DIMENSIONS

*All dimensions are nominal

Device	Package Type	Package Drawing	Pins	SPQ	Length (mm)	Width (mm)	Height (mm)
DS99R103TSQ/NOPB	WQFN	NJU	48	250	210.0	185.0	35.0
DS99R103TSQX/NOPB	WQFN	NJU	48	2500	367.0	367.0	38.0
DS99R104TSQ/NOPB	WQFN	NJU	48	250	210.0	185.0	35.0
DS99R104TSQX/NOPB	WQFN	NJU	48	2500	367.0	367.0	38.0

NJU0048D

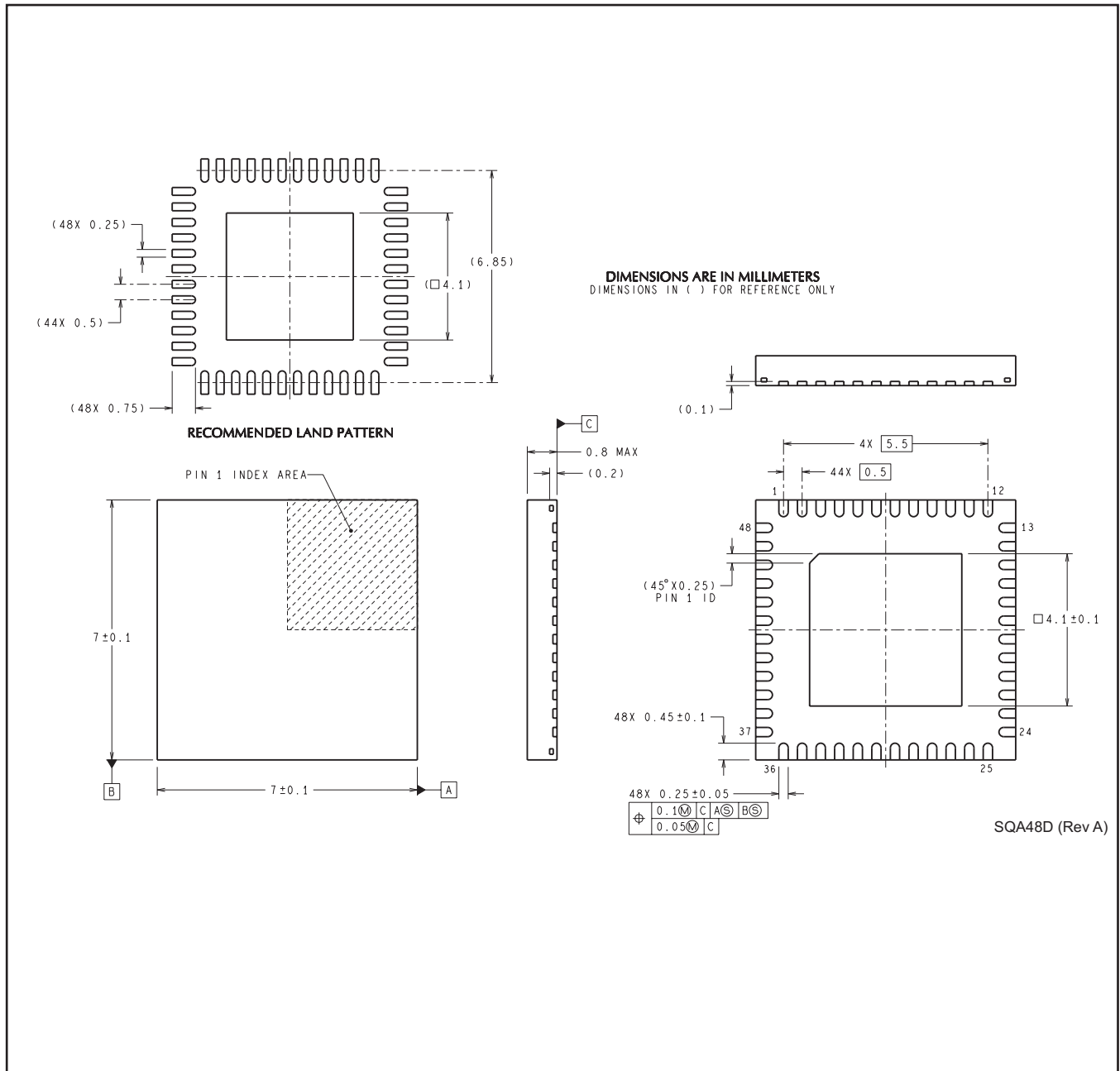

SQA48D (Rev A)

PFB (S-PQFP-G48)

PLASTIC QUAD FLATPACK

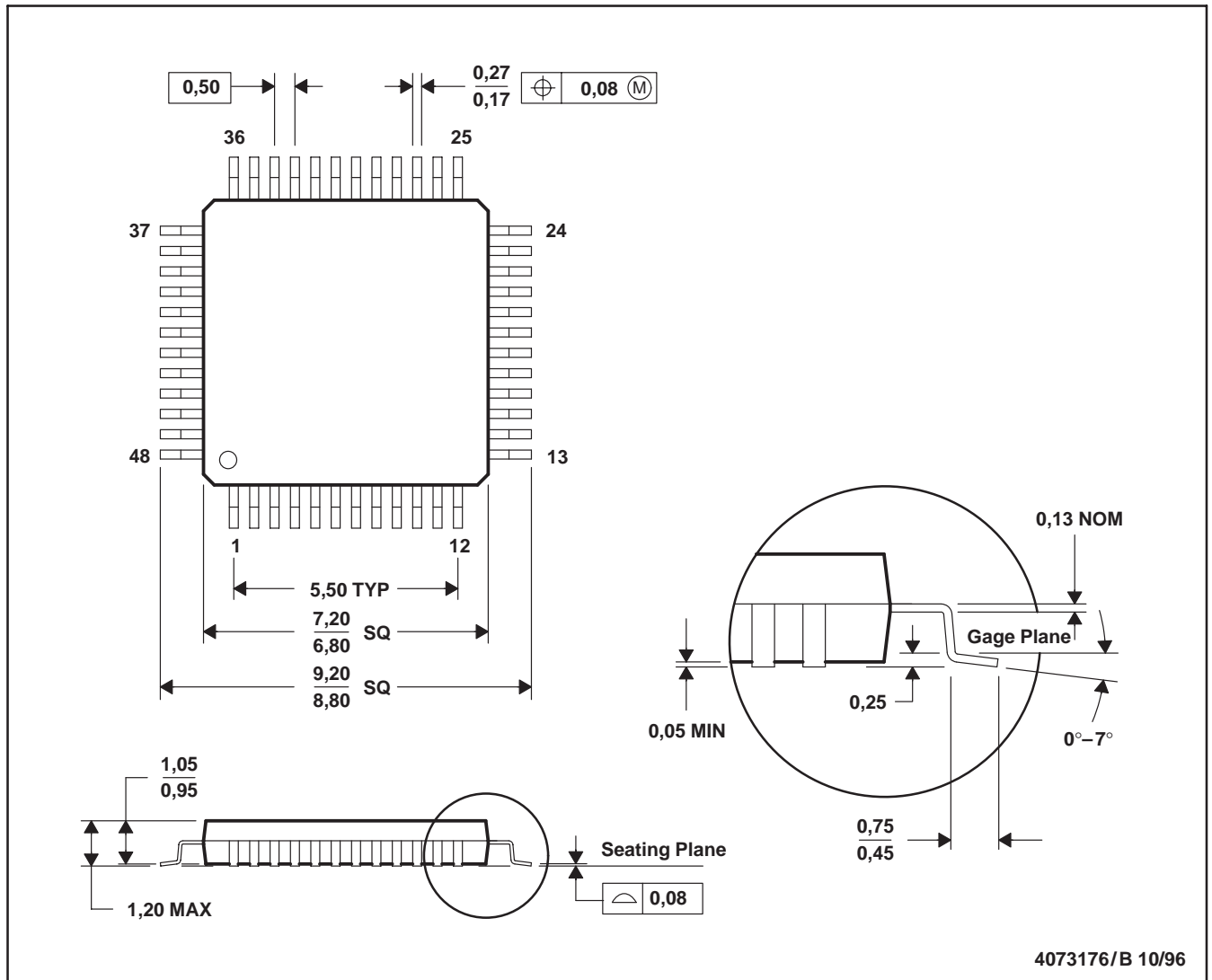

- NOTES: A. All linear dimensions are in millimeters.
 B. This drawing is subject to change without notice.
 C. Falls within JEDEC MS-026

IMPORTANT NOTICE AND DISCLAIMER

TI PROVIDES TECHNICAL AND RELIABILITY DATA (INCLUDING DATASHEETS), DESIGN RESOURCES (INCLUDING REFERENCE DESIGNS), APPLICATION OR OTHER DESIGN ADVICE, WEB TOOLS, SAFETY INFORMATION, AND OTHER RESOURCES "AS IS" AND WITH ALL FAULTS, AND DISCLAIMS ALL WARRANTIES, EXPRESS AND IMPLIED, INCLUDING WITHOUT LIMITATION ANY IMPLIED WARRANTIES OF MERCHANTABILITY, FITNESS FOR A PARTICULAR PURPOSE OR NON-INFRINGEMENT OF THIRD PARTY INTELLECTUAL PROPERTY RIGHTS.

These resources are intended for skilled developers designing with TI products. You are solely responsible for (1) selecting the appropriate TI products for your application, (2) designing, validating and testing your application, and (3) ensuring your application meets applicable standards, and any other safety, security, or other requirements. These resources are subject to change without notice. TI grants you permission to use these resources only for development of an application that uses the TI products described in the resource. Other reproduction and display of these resources is prohibited. No license is granted to any other TI intellectual property right or to any third party intellectual property right. TI disclaims responsibility for, and you will fully indemnify TI and its representatives against, any claims, damages, costs, losses, and liabilities arising out of your use of these resources.

TI's products are provided subject to TI's Terms of Sale (www.ti.com/legal/termsofsale.html) or other applicable terms available either on ti.com or provided in conjunction with such TI products. TI's provision of these resources does not expand or otherwise alter TI's applicable warranties or warranty disclaimers for TI products.

Mailing Address: Texas Instruments, Post Office Box 655303, Dallas, Texas 75265
Copyright © 2018, Texas Instruments Incorporated

Looking for pricing, stock, or lifecycle information?

Click below to explore more details on WIN SOURCE:

 [View DS99R103TSQX/NOPB on WIN SOURCE](#)

 [Texas Instruments](#) Information

Optimize Your Supply Chain with WIN SOURCE Solutions

-  Global Sourcing Solution
-  Obsolete Management
-  Cost Control Management
-  Shortage Management
-  Alternative Solution
-  Excess Inventory Management