



**THE DATASHEET OF**  
**2861263**



# IB IL 24 DO 2-2A ...

## Inline terminal with two digital outputs

### AUTOMATION

Data sheet  
5556\_en\_04

© PHOENIX CONTACT 2010-11-23

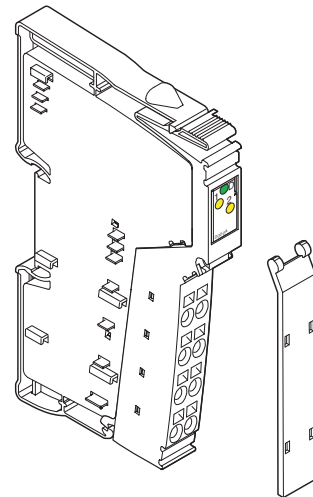

## 1 Description

This terminal is designed for use within an Inline station. It is used to output digital signals.

### Features

- Connections for two digital actuators
- Connection of actuators in 2, 3, and 4-wire technology
- Nominal current of each output: 2 A
- Total current of the terminal: 4 A
- Short-circuit and overload protected outputs
- Diagnostic and status indicators
- Approved for the use in potentially explosive areas (observe the notes on page 8)
- Approved for use within a safety-related segment circuit (observe the notes on page 7)



This data sheet is only valid in association with the IL SYS INST UM E user manual.



Make sure you always use the latest documentation.  
It can be downloaded at [www.phoenixcontact.net/catalog](http://www.phoenixcontact.net/catalog).



This data sheet is valid for all products listed on the following page:

## 2 Ordering data

### Products

Description	Type	Order No.	Pcs./Pkt.
Terminal with two digital outputs; complete with accessories (connector and labeling field); transmission speed of 500 kbps	IB IL 24 DO 2-2A-PAC	2861263	1
Terminal with two digital outputs; without accessories; transmission speed of 500 kbps	IB IL 24 DO 2-2A	2726243	1
Terminal with two digital outputs; complete with accessories (connector and labeling field); transmission speed of 2 Mbps	IB IL 24 DO 2-2A-2MBD-PAC	2861700	1
Terminal with two digital outputs; without accessories; transmission speed of 2 Mbps	IB IL 24 DO 2-2A-2MBD	2819053	1



One of the listed connectors is needed for the complete fitting of the IB IL 24 DO 2-2A and IB IL 24 DO 2-2A-2MBD terminals.

### Accessories

Description	Type	Order No.	Pcs./Pkt.
Connector with eight spring-cage connections (green, w/o color print)	IB IL SCN-8	2726337	10
Connector with eight spring-cage connections (green, with color print)	IB IL SCN-8-CP	2727608	10

### Documentation

Description	Type	Order No.	Pcs./Pkt.
"Configuring and installing the INTERBUS Inline product range" user manual	IB IL SYS PRO UM E	2743048	1
"Automation terminals of the Inline product range" user manual	IL SYS INST UM E	2698737	1
"INTERBUS addressing" data sheet	DB GB IBS SYS ADDRESS	-	-
"Inline terminals for use in zone 2 potentially explosive areas" application note	AH EN IL EX ZONE 2	-	-
"Safety-related segment circuit" application note	AH EN IL SAFE	-	-

## 3 Technical data

### General data

Housing dimensions (width x height x depth)	12.2 mm x 119.8 mm x 71.5 mm
Weight	46 g (without connector), 61 g (with connector)
Operating mode	Process data mode with 2 bits
Connection method for actuators	2, 3, and 4-wire technology
Permissible temperature (operation)	-25°C to +55°C
Permissible temperature (storage/transport)	-25°C to +85°C
Permissible humidity (operation/storage/transport)	10% to 95% according to DIN EN 61131-2
Permissible air pressure (operation/storage/transport)	70 kPa to 106 kPa (up to 3000 m above sea level)
Degree of protection	IP20 according to IEC 60529
Protection class	Class 3, according to EN 61131-2, IEC 61131-2
Connection data for connectors	
Connection method	Spring-cage terminals
Conductor cross-section	0.08 mm <sup>2</sup> to 1.5 mm <sup>2</sup> (solid or stranded), 28 - 16 AWG

### Interface

Local bus	Via data routing
-----------	------------------

**Transmission speed**

IB IL 24 DO 2-2A-PAC, IB IL 24 DO 2-2A	500 kbps
IB IL 24 DO 2-2A-2MBD-PAC, IB IL 24 DO 2-2A-2MBD	2 Mbps

**Supply of the module electronics and I/O through the bus terminal/power terminal**

Connection method	Via potential routing
-------------------	-----------------------

**Power consumption**

	500 kbps	2 Mbps
Communications power	7.5 V	7.5 V
Current consumption from the local bus	35 mA, maximum	60 mA, maximum
Power consumption from the local bus	0.27 W, maximum	0.45 W, maximum
Segment supply voltage $U_S$	24 V DC (nominal value)	24 V DC (nominal value)
Nominal current consumption at $U_S$	4 A (2 x 2 A), maximum	4 A (2 x 2 A), maximum

**Digital outputs**

Number	2
Nominal output voltage $U_{OUT}$	24 V DC
Differential voltage for $I_{nom}$	$\leq 1$ V
Nominal current $I_{nom}$ per channel	2 A
Tolerance of the nominal current	+10%
Total current	4 A
Protection	Short circuit; overload
Nominal load	
Ohmic	12 $\Omega$ /48 W
Lamp	48 W
Inductive	48 VA (1.2 H, 12 $\Omega$ )
Signal delay upon power up of:	
Nominal ohmic load	200 $\mu$ s, approximately
Nominal lamp load	200 ms, typical (with switching frequencies up to 8 Hz; above this frequency the lamp load responds like an ohmic load)
Nominal inductive load	250 ms (1.2 H, 12 $\Omega$ ), approximately
Signal delay upon power down of:	
Nominal ohmic load	200 $\mu$ s, approximately
Nominal lamp load	200 $\mu$ s, approximately
Nominal inductive load	250 ms (1.2 H, 12 $\Omega$ ), approximately
Switching frequency with:	
Nominal ohmic load	300 Hz, maximum



This switching frequency is limited by the selected data rate, the number of bus devices, the bus structure, the software and the control or computer system used.

Nominal lamp load	300 Hz, maximum
-------------------	-----------------



This switching frequency is limited by the selected data rate, the number of bus devices, the bus structure, the software and the control or computer system used.

Nominal inductive load	0.5 Hz (1.2 H, 12 $\Omega$ ) maximum
Overload response	Auto restart
Response with inductive overload	Output may be damaged
Reverse voltage protection against short pulses	Protected against reverse voltages
Resistance to permanently applied reverse voltages	Up to 2 A DC
Validity of output data after connecting the 24 V voltage supply (power up)	5 ms, typical
Response upon power down	The output follows the supply voltage without delay.

**Digital outputs (continued)**

Limitation of the voltage induced on circuit interruption	-0.7 V, approximately
Maximum inductive breaking energy/channel	1500 W (8/20 µs pulse)
Protective circuit type	Free-wheeling diode per channel

**Output characteristic curve when switched on (typical)**

Output current (A)	Differential output voltage (V)	
	500 kbps	2 Mbps
	0	0
0.2	0.02	0.013
0.4	0.04	0.026
0.6	0.06	0.039
0.8	0.08	0.053
1.0	0.10	0.066
1.2	0.12	0.079
1.4	0.14	0.093
1.6	0.16	0.107
1.8	0.18	0.122
2.0	0.20	0.136
2.2	0.22	

**Power dissipation**

**Formula to calculate the power dissipation of the electronics**

**500 kbps**

$$P_{EL} = 0.18 \text{ W} + \sum_{n=1}^2 (200 \text{ mW} + I_{Ln}^2 \times 0.1 \Omega)$$

**2 Mbps**

$$P_{EL} = 0.40 \text{ W} + \sum_{n=1}^2 (35 \text{ mW} + I_{Ln}^2 \times 0.075 \Omega)$$

Where:

- $P_{EL}$  Total power dissipation in the terminal
- $n$  Index of the number of set outputs  $n = 1$  to  $2$
- $I_{Ln}$  load current of output  $n$

**Power dissipation of the housing depending on the ambient temperature**

**500 kbps**

$$P_{HOU} = 2.4 \text{ W} \quad -25^\circ\text{C} < T_A \leq -5^\circ\text{C}$$

$$P_{HOU} = 2.4 \text{ W} - \frac{T_A - (-5^\circ\text{C})}{37.5 \text{ K/W}} \quad -5^\circ\text{C} < T_A \leq +55^\circ\text{C}$$

**2 Mbps**

0.6 W (within the permissible operating temperature)

Where:

- $P_{HOU}$  Permissible power dissipation of the housing
- $T_A$  Ambient temperature

**Limitation of simultaneity, derating (500 kbps)**

Ambient temperature (TA)	Maximum load current at 100% simultaneity	Maximum load current at 50% simultaneity
55°C	1 A	2 A
40°C	2 A	2 A

With an ambient operating temperature of 55°C and 100% simultaneity, a load current of 1 A per channel is permissible. If only one channel is used (50% simultaneity), a load current of 2 A can be tapped. With an ambient temperature of 40°C, a maximum load current of 2.0 A can be tapped in both cases.

If both channels are used, the permissible working point must be defined according to the above formulas. For an example, please refer to the IB IL SYS PRO UM E user manual or the Inline system manual for your bus system.

**Limitation of simultaneity, derating (2 Mbps)**

Ambient temperature (TA)	Maximum load current at 100% simultaneity	Maximum load current at 50% simultaneity
55°C	0.7 A	1.2 A
35°C	2 A	2 A

With an ambient operating temperature of 55°C and 100% simultaneity, a load current of 0.7 A per channel is permissible. If only one channel is used (50% simultaneity), a load current of 1.2 A can be tapped. With an ambient temperature of 35°C, a maximum load current of 2 A can be tapped in both cases.

If both channels are used, the permissible working point must be defined according to the above formulas. For an example, please refer to the IB IL SYS PRO UM E user manual or the Inline system manual for your bus system.

**Protective equipment**

Overload/short circuit in the segment circuit	Electronic
Surge voltage	Protective elements of the power terminal
Polarity reversal	Protective elements of the power terminal

**Electrical isolation/isolation of the voltage areas**



To provide electrical isolation between the logic level and the I/O area it is necessary to supply the station bus coupler and the digital output terminal described here via the bus coupler or a power terminal from separate power supply units. Interconnection of the power supply units in the 24 V area is not permitted. (See also user manual.)

**Common potentials**

The 24 V main voltage, 24 V segment voltage, and GND have the same potential. FE is a separate potential area.

**Separate potentials in the system consisting of bus terminal/power terminal and I/O terminal**

Test distance	Test voltage
5 V supply incoming remote bus/7.5 V supply (bus logic)	500 V AC, 50 Hz, 1 min.
5 V supply outgoing remote bus/7.5 V supply (bus logic)	500 V AC, 50 Hz, 1 min.
7.5 V supply (bus logic) / 24 V supply (I/O)	500 V AC, 50 Hz, 1 min.
24 V supply (I/O) / functional earth ground	500 V AC, 50 Hz, 1 min.

**Error messages to the higher-level control or computer system**

Short circuit/overload of an output	Yes
Operating voltage out of range	No



An error message is generated when an output is shorted and switched on. In addition, the diagnostic LED (D) flashes on the terminal at 2Hz (medium) under these conditions.

**Approvals**

For the latest approvals, please visit [www.phoenixcontact.net/catalog](http://www.phoenixcontact.net/catalog).

#### 4 Internal basic circuit diagram

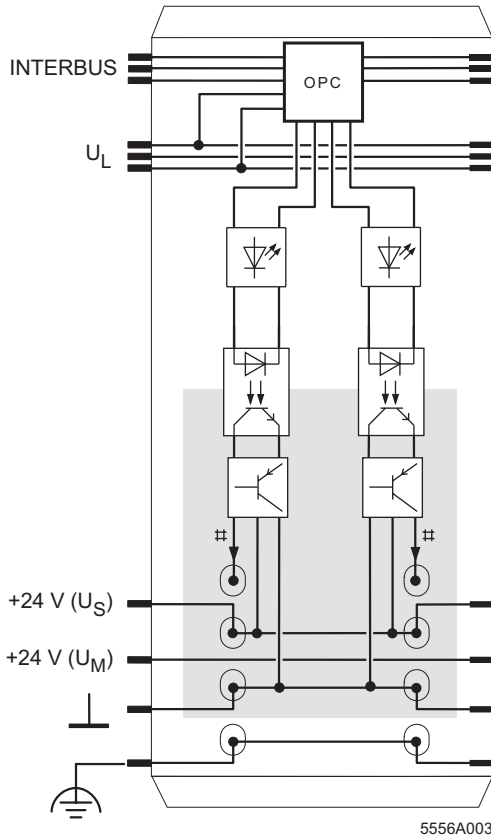









Figure 1 Internal wiring of the terminal points

Key:

-  Protocol chip (bus logic including voltage conditioning)
-  LED
-  Optocoupler
-  Transistor
-  Digital output
-  Electrically isolated area

 Other symbols used are explained in the IL SYS INST UM E user manual.

#### 5 Local diagnostic and status indicators and terminal point assignment

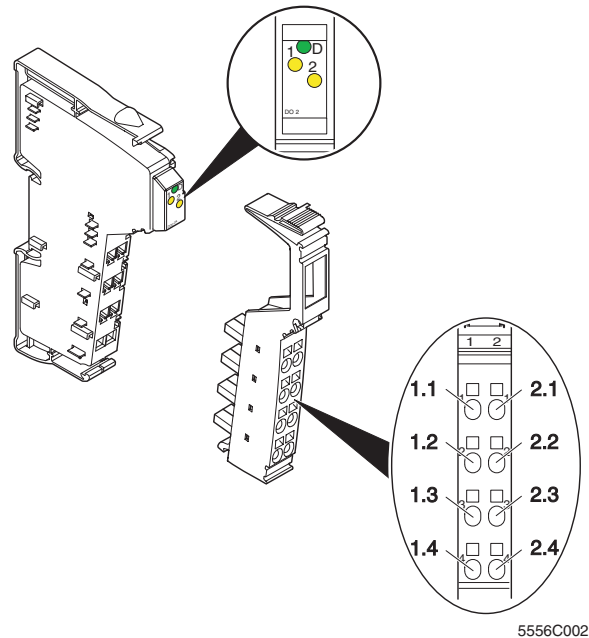

Figure 2 IB IL 24 DO 2-2A with appropriate connector

##### 5.1 Local diagnostic and status indicators

Des.	Color	Meaning
D	Green	Diagnostics
1, 2	Yellow	Status indicators for the outputs

##### 5.2 Function identification

Pink

2 MBD: White stripe in the vicinity of the D LED

##### 5.3 Terminal point assignment

Terminal points	Assignment
1.1, 2.1	Signal output (OUT)
1.2, 2.2	Segment voltage $U_S$ for 4-wire termination Measuring point for the supply voltage
1.3, 2.3	Ground contact (GND) for 2, 3, and 4-wire termination
1.4, 2.4	FE connection for 3 and 4-wire termination

## 6 Connection example



When connecting the actuators observe the assignment of the terminal points to the process data, see page 9.

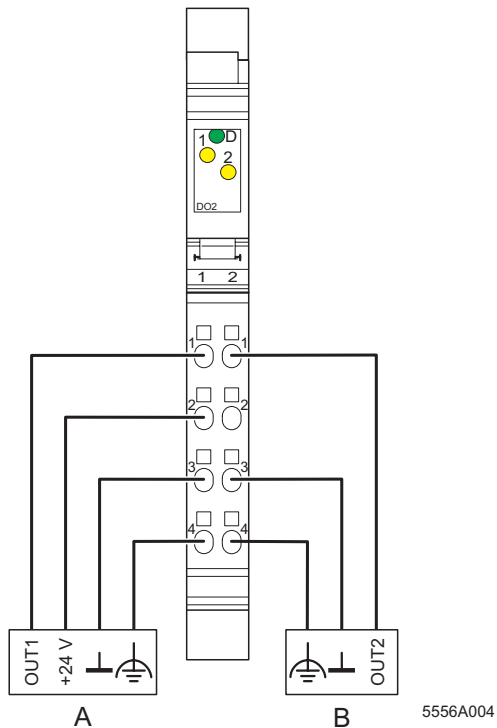

Figure 3 Typical connection of actuators

- A 4-wire termination
- B 3-wire termination

## 7 Notes on using the terminals within a safety-related segment circuit

The terminals of the following hardware version and later (listed in the table below) are approved for use within a safety-related segment circuit.

Order No.	Order designation	Hardware version
2861263	IB IL 24 DO 2-2A-PAC	06
2726243	IB IL 24 DO 2-2A	05
2861700	IB IL 24 DO 2-2A-2MBD-PAC	03
2819053	IB IL 24 DO 2-2A-2MBD	03



The hardware version is marked on the side of the housing of every terminal (1 in Figure 4).

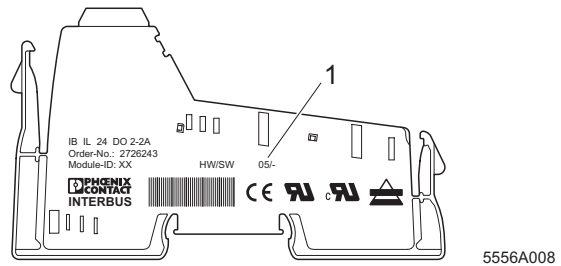

Figure 4 Labeling on an Inline terminal



The instructions in the current documentation for the safety terminal used and from the AH EN IL SAFE application note must be observed to ensure that operation of the safety-related segment circuit is not adversely affected. The latest documentation can be downloaded at [www.phoenixcontact.net/catalog](http://www.phoenixcontact.net/catalog).

## 8 Notes on using the terminal in potentially explosive areas



### WARNING: Explosion hazard

Please make sure that the following notes and instructions are observed.

### Approval according to EC directive 94/9/EC

 II 3G Ex nAC IIC T4 X

### Installation notes

1. This Inline terminal can be installed in zone 2.
2. The Inline terminal must only be installed, operated, and maintained by qualified personnel.
3. Please follow the installation instructions given in the IL SYS INST UM E user manual and the package slip.
4. When installing and operating the device, the applicable safety directives (including national safety directives), accident prevention regulations, as well as general technical regulations must be observed.
5. Please refer to the corresponding documentation (user manual, data sheet, package slip) and the certificates (EC type examination certificate and other approvals, if applicable) for safety-related data.
6. It is not permitted to access the circuits inside the Inline terminal. Do not repair the Inline terminal by yourself but replace it with a terminal of the same type. Repairs may only be carried out by the manufacturer.
7. The IP20 degree of protection (EN 60529) of the device is intended for a clean and dry environment.
8. Do not subject the Inline terminal to mechanical strain and/or thermal loads, which exceed the limits specified in the product documentation.
9. The Inline terminal has not been designed for use in potentially dust-explosive atmospheres.

### Installation in zone 2

1. Observe the specified conditions for use in potentially explosive areas.
2. When installing the terminal, use an appropriate and approved housing with a minimum protection of IP54. Please observe the EN 60079-14 requirements, e.g., a steel housing with a wall thickness of 3 mm.
3. In potentially explosive areas, only snap the Inline terminal onto the rail and connect the cables when the power is switched off.
4. In zone 2, only connect devices to the supply and signal circuits that are suitable for operation in potentially explosive areas of zone 2 and the conditions at the installation location.

### Restrictions/limit values

1. Only Inline terminals that are approved for use in potentially explosive areas may be snapped next to this Inline terminal.  
Before using the Inline terminal in a zone 2 potentially explosive atmosphere, check whether it has been approved for installation within this area.  
For a list of terminals approved for zone 2 potentially explosive areas, please refer to the AH EN IL EX ZONE 2 application note.
2. Please make sure that the maximum permissible current of 4 A flowing through potential jumpers  $U_M$  und  $U_S$  (total current) is not exceeded when using the Inline terminals in potentially explosive areas.
3. The maximum permissible current for each tension spring contact is 2 A.

## 9 Programming data/ configuration data

### 9.1 Local bus (INTERBUS)

ID code	BD <sub>hex</sub> (189 <sub>dec</sub> )
Length code	C2 <sub>hex</sub>
Process data channel	2 bits
Input address area	0 bits
Output address area	2 bits
Parameter channel (PCP)	0 bits
Register length (bus)	2 bits

### 9.2 Other bus systems



For the programming data/configuration data of other bus systems, please refer to the corresponding electronic device data sheet (GSD, EDS).

## 10 Process data

### 10.1 Assignment of the output process data

(Byte.bit) view		0.1	0.0
Module	<b>Terminal point (signal)</b>	<b>2.1</b>	<b>1.1</b>
	Terminal point (+24 V)	2.2	1.2
	Terminal point (GND)	2.3	1.3
	Terminal point (FE)	2.4	1.4
Status indicator	LED	2	1



For the assignment of the illustrated (byte.bit) view to your **INTERBUS** control or computer system, please refer to the DB GB IBS SYS ADDRESS data sheet.

## Looking for pricing, stock, or lifecycle information?

Click below to explore more details on WIN SOURCE:

 [View 2861263 on WIN SOURCE](#)

 [Phoenix Contact](#) Information

## Optimize Your Supply Chain with WIN SOURCE Solutions

-  Global Sourcing Solution
-  Obsolete Management
-  Cost Control Management
-  Shortage Management
-  Alternative Solution
-  Excess Inventory Management