



THE DATASHEET OF

5-1903015-1

win-source.net



0086-755-83957316

THIS DRAWING IS UNPUBLISHED. RELEASED FOR PUBLICATION SEP. 2005.
 © COPYRIGHT 2005 By - ALL RIGHTS RESERVED.

LOC	DIST	REVISIONS					
		P	LTR	DESCRIPTION	DATE	DWN	APVD
-	-	S		REVISED PER ECR-15-016490	11NOV2015	T.Z	H.W

- 1 CONTACT COPLANALITY IS 0.1 MAX.
- 2 THIS DIMENSION MEANS CENTER OF THE POCKET.
- 3 M3 TAPPING + BVTP RECOMMENDED TORQUE: 68.6N (7Kgf) MAX.
- 4 FINISH
CONTACT: V μm MIN. Au PL. ON CONTACT AREA (V: SEE TABLE)
0.03~0.1 μm Au PL. ON TERMINAL AREA
Ni UNDER PL. ALL OVER
SHELL: Sn PL. (MATTE) ALL OVER
Ni UNDER PL. ALL OVER
- 5 SCREW SIZE
- 6 QTY PRINT ON THE LABEL. (EMBOSS PACKING)

- 1 コンタクトコプラナリティーは 0.1 以下。
- 2 本寸法はポケットの中心を表す。
- 3 M3 TAPPING + BVTP 推奨トルク: 68.6N (7Kgf) 以下。
- 4 仕上
コンタクト: コンタクトエリアに V μm 以上の 金めっき (V: 表参照)
ターミナルエリアに 0.03~0.1 μm の金めっき
ニッケル下地めっきを施す
シェル: すずめっき (つや消し)
ニッケル下地めっきを施す
- 5 スクリューサイズ
- 6 数量はラベルに印字される (EMBOSS 梱包)

0.3	-	70	1.9	-	-	-	-	33.5	37.5	9.32	0.4	32	28.4	14.2	16	WITHOUT TAPE	WITHOUT FLANGE	THROUGH HOLE	(SEE SHEET 2)	SOFT TRAY (SEE SHEET 11)	6-1903015-3
0.76	M3 x 0.5	70	1.9	46	138	6-23	46	-	-	-	-	-	-	-	-	WITH TAPE	WITH FLANGE	THROUGH HOLE	(SEE SHEET 3)	SOFT TRAY (SEE SHEET 7)	9-1903015-4
0.3	M3 x 0.5	200	1.9	-	-	-	-	45.5	49.5	18.3	0.5	44	40.4	20.2	20	WITH TAPE	WITH FLANGE	THROUGH HOLE	(SEE SHEET 3)	EMBOSS (SEE SHEET 6)	9-1903015-3
0.3	M3 x 0.5	70	1.9	-	-	-	-	-	-	-	-	-	-	-	-	WITHOUT TAPE	WITH FLANGE	THROUGH HOLE	(SEE SHEET 3)	SOFT TRAY (SEE SHEET 10)	8-1903015-4
0.1	-	550	1.9	-	-	-	-	33.5	37.5	9.32	0.4	32	28.4	14.2	16	WITHOUT TAPE	WITHOUT FLANGE	THROUGH HOLE	(SEE SHEET 2)	EMBOSS (SEE SHEET 6)	7-1903015-1
0.3	M3 x 0.5	200	1.9	-	-	-	-	45.5	49.5	18.3	0.5	44	40.4	20.2	20	WITHOUT TAPE	WITH FLANGE	FULL SMT	(SEE SHEET 5)	EMBOSS (SEE SHEET 6)	5-1903015-9
0.3	-	550	0.8	-	-	-	-	33.5	37.5	9.32	0.4	32	28.4	14.2	16	WITHOUT TAPE	WITHOUT FLANGE	THROUGH HOLE	(SEE SHEET 2)	EMBOSS (SEE SHEET 6)	5-1903015-5
0.3	M3 x 0.5	70	1.9	46	138	6-23	46	-	-	-	-	-	-	-	-	WITHOUT TAPE	WITH FLANGE	THROUGH HOLE	(SEE SHEET 3)	SOFT TRAY (SEE SHEET 7)	5-1903015-4
0.3	M3 x 0.5	200	1.9	-	-	-	-	45.5	49.5	18.3	0.5	44	40.4	20.2	20	WITHOUT TAPE	WITH FLANGE	THROUGH HOLE	(SEE SHEET 3)	EMBOSS (SEE SHEET 6)	5-1903015-3
0.3	∅2.65±0.3	70	1.9	46	138	6-23	46	-	-	-	-	-	-	-	-	WITHOUT TAPE	WITH FLANGE	THROUGH HOLE	(SEE SHEET 3)	SOFT TRAY (SEE SHEET 7)	5-1903015-2
0.3	-	400	1.9	-	-	-	-	33.5	37.5	9.32	0.4	32	28.4	14.2	16	WITHOUT TAPE	WITHOUT FLANGE	THROUGH HOLE	(SEE SHEET 2)	EMBOSS (SEE SHEET 6)	5-1903015-1
0.3	M3 x 0.5	70	1.0	46	138	6-23	46	-	-	-	-	-	-	-	-	WITHOUT TAPE	WITH FLANGE	THROUGH HOLE	(SEE SHEET 3)	SOFT TRAY (SEE SHEET 7)	4-1903015-1
0.76	-	400	1.2	-	-	-	-	33.5	37.5	9.32	0.4	32	28.4	14.2	16	WITHOUT TAPE	WITHOUT FLANGE	THROUGH HOLE	(SEE SHEET 2)	EMBOSS (SEE SHEET 6)	2-1903015-2
0.76	M3 x 0.5	70	1.9	-	-	-	-	-	-	-	-	-	-	-	-	WITHOUT TAPE	WITH FLANGE	THROUGH HOLE	(SEE SHEET 3)	SOFT TRAY (SEE SHEET 9)	1903015-8
0.76	∅2.65±0.3	70	1.9	-	-	-	-	-	-	-	-	-	-	-	-	WITHOUT TAPE	WITH FLANGE	THROUGH HOLE	(SEE SHEET 3)	SOFT TRAY (SEE SHEET 9)	1903015-7
0.76	M3 x 0.5	50	1.9	54.4	120	4-30	54.4	-	-	-	-	-	-	-	-	WITHOUT TAPE	WITH FLANGE	THROUGH HOLE	(SEE SHEET 3)	SOFT TRAY (SEE SHEET 9)	1903015-5
0.76	M3 x 0.5	70	1.9	46	138	6-23	46	-	-	-	-	-	-	-	-	WITHOUT TAPE	WITH FLANGE	THROUGH HOLE	(SEE SHEET 4)	SOFT TRAY (SEE SHEET 8)	1903015-4
0.76	M3 x 0.5	200	1.9	-	-	-	-	45.5	49.5	18.3	0.5	44	40.4	20.2	20	WITHOUT TAPE	WITH FLANGE	THROUGH HOLE	(SEE SHEET 4)	EMBOSS (SEE SHEET 6)	1903015-3
0.76	∅2.65±0.3	70	1.9	46	138	6-23	46	-	-	-	-	-	-	-	-	WITHOUT TAPE	WITH FLANGE	THROUGH HOLE	(SEE SHEET 3)	SOFT TRAY (SEE SHEET 7)	1903015-2
0.76	-	400	1.9	-	-	-	-	33.5	37.5	9.32	0.4	32	28.4	14.2	16	WITHOUT TAPE	WITHOUT FLANGE	THROUGH HOLE	(SEE SHEET 2)	EMBOSS (SEE SHEET 6)	1903015-1
V	U	T	AA	S	R	P	N	M	L	K	J	H	G	F	E	POLYIMIDE TAPE	FLANGE	SHELL TYPE	CONNECTOR	PACKING	PART NUMBER

4 Au PL. 5 SCREW SIZE QTY DIMENSION PART LIST

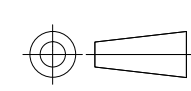
THIS DRAWING IS A CONTROLLED DOCUMENT.		DWN R.MURAYAMA 26SEP2005	 TE Connectivity	
DIMENSIONS: 単位: 概 mm 		CHK T.KIMURA 26SEP2005		
TOLERANCES UNLESS OTHERWISE SPECIFIED: 一般公差 0 PLC ± 1 PLC ± 2 PLC ± 3 PLC ± 4 PLC ± ANGLES ±		APVD T.KIMURA 26SEP2005	NAME 名称 HDMI 19 POS RECEPTACLE ASSY SMT SHORT TYPE	
MATERIAL 材料		PRODUCT SPEC 製品規格 108-78180-2	SIZE A3	
FINISH 仕上		APPLICATION SPEC 取付適用規格	CAGE CODE 00779	DRAWING NO 番号 C-1903015
WEIGHT		RESTRICTED TO		SCALE 尺度 4:1
CUSTOMER DRAWING		SHEET 1 of 12		REV S

THIS DRAWING IS UNPUBLISHED. RELEASED FOR PUBLICATION SEP ,2005.
 © COPYRIGHT 2005 By - ALL RIGHTS RESERVED.

LOC		DIST		REVISIONS			DATE	DWN	APVD
		P	LTR	DESCRIPTION					
				SEE SHEET 1			-	-	-

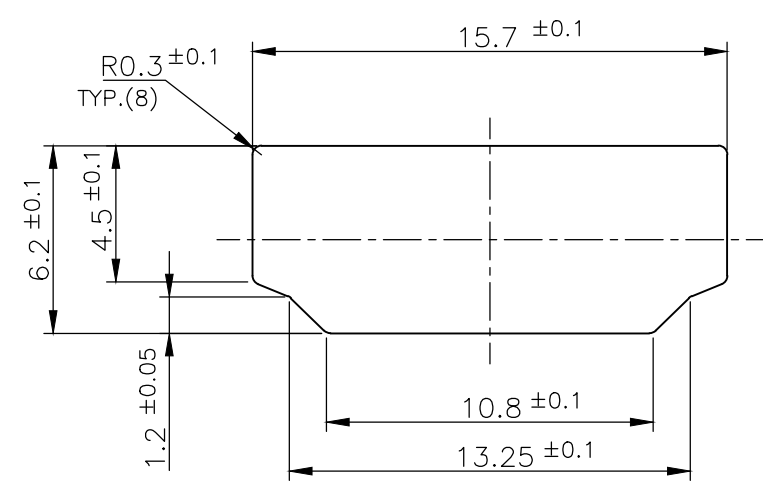
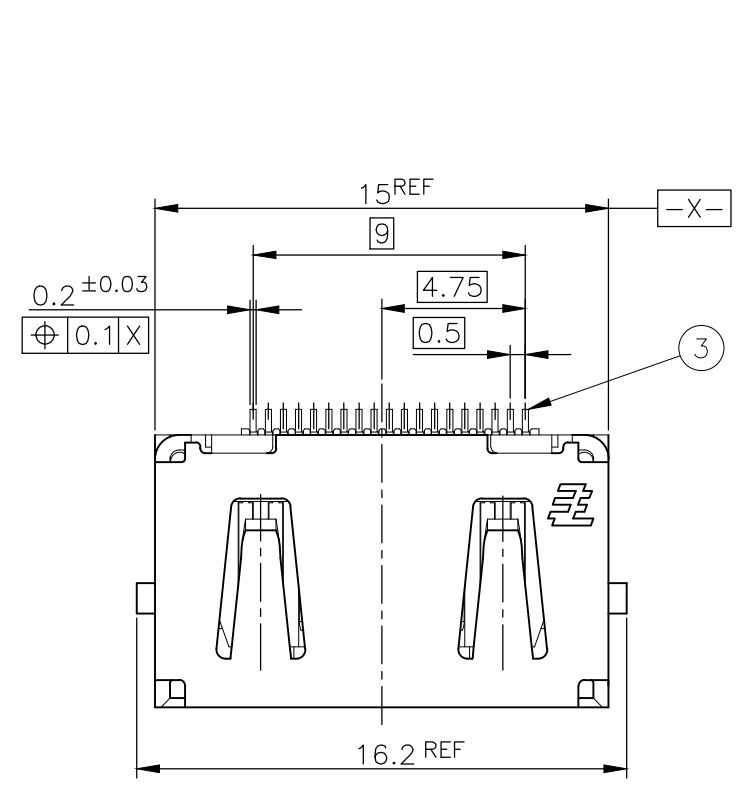

PANEL CUT OUT DIMENSION (REFERENCE)

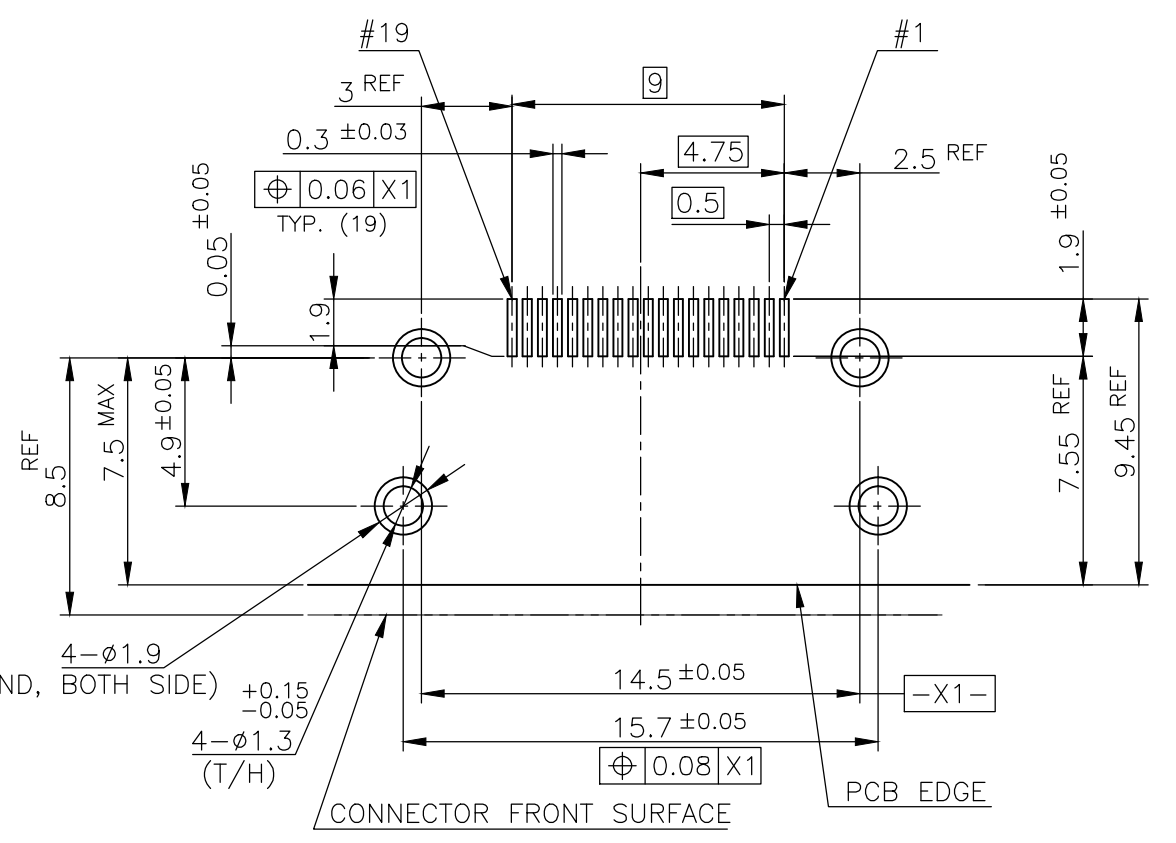

P.C.B LAYOUT (REFERENCE)
 SHOWN AS CONNECTOR MOUNTING SIDE
 TOLERANCE: NON-CUMULATIVE

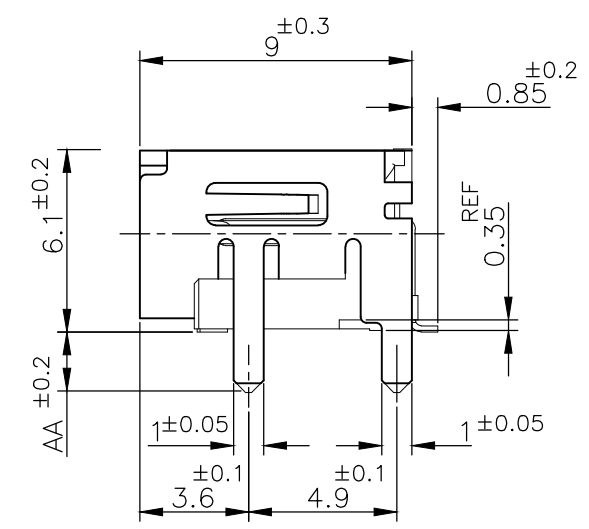
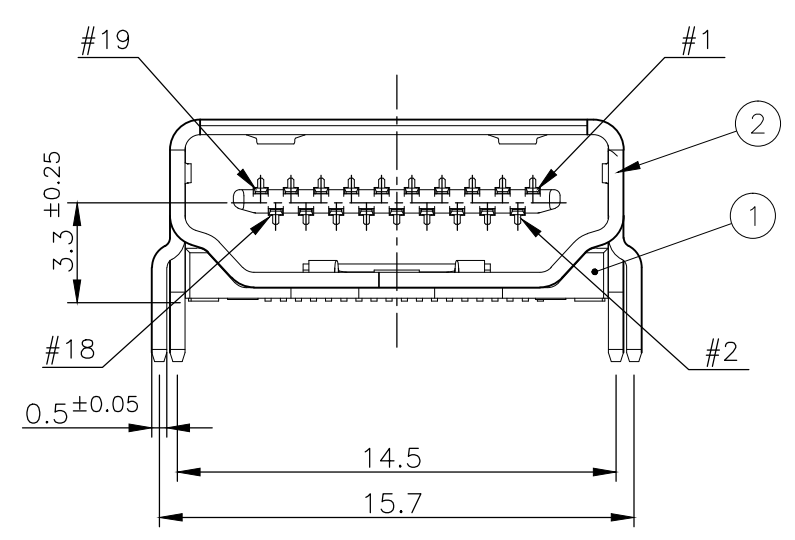

CONNECTOR: WITHOUT FLANGE THROUGH HOLE TYPE

BRASS	CONTACT	③
PHOSPHOR BRONZE	SHELL	②
GLASS FILLED LCP UL94V-0, BLACK COLOR	HOUSING	①
MATERIAL	DESCRIPTION	ITEM

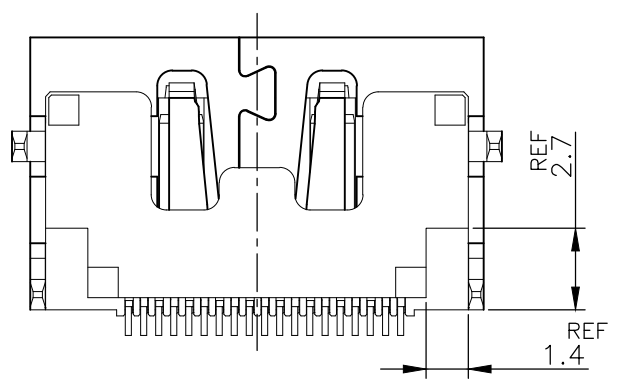

THIS DRAWING IS A CONTROLLED DOCUMENT.		DWN	TE Connectivity NAME 名称 HDMI 19 POS RECEPTACLE ASSY SMT SHORT TYPE				
DIMENSIONS: 单位: 耗 mm		CHK					
TOLERANCES UNLESS OTHERWISE SPECIFIED: 一般公差		APVD					
0 PLC ± 1 PLC ± 2 PLC ± 3 PLC ± 4 PLC ± ANGLES ±		PRODUCT SPEC 製品規格					
MATERIAL 材料		FINISH 仕上	APPLICATION SPEC 取付適用規格	SIZE	CAGE CODE	DRAWING NO 番号	RESTRICTED TO
		WEIGHT	CUSTOMER DRAWING	A3	00779	G-1903015	
			SCALE 尺度 4:1	SHEET 2 OF 12		REV S	

LOC	DIST	REVISIONS		
		P	LTR	DESCRIPTION
-	-	-	-	SEE SHEET 1
				DATE
				DWN
				APVD

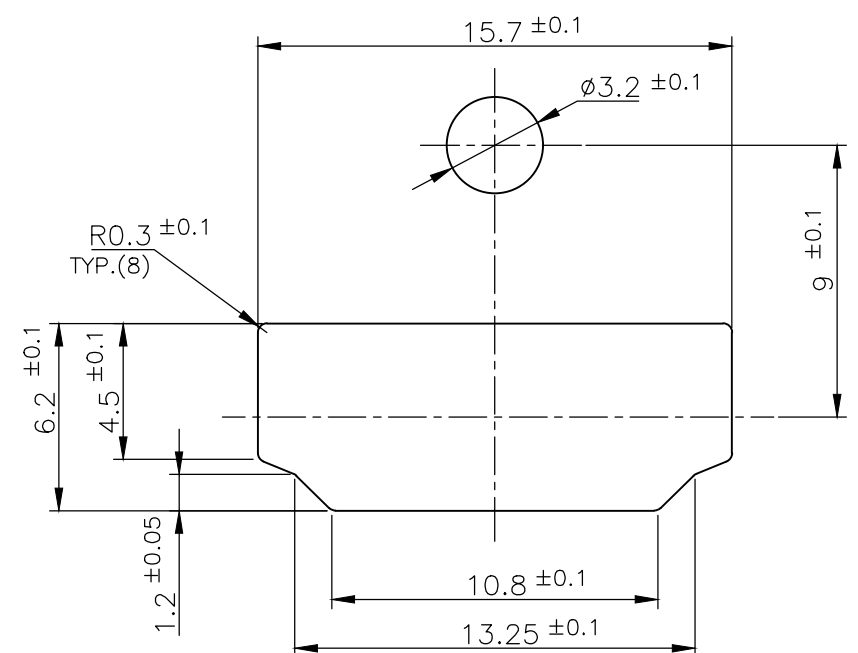
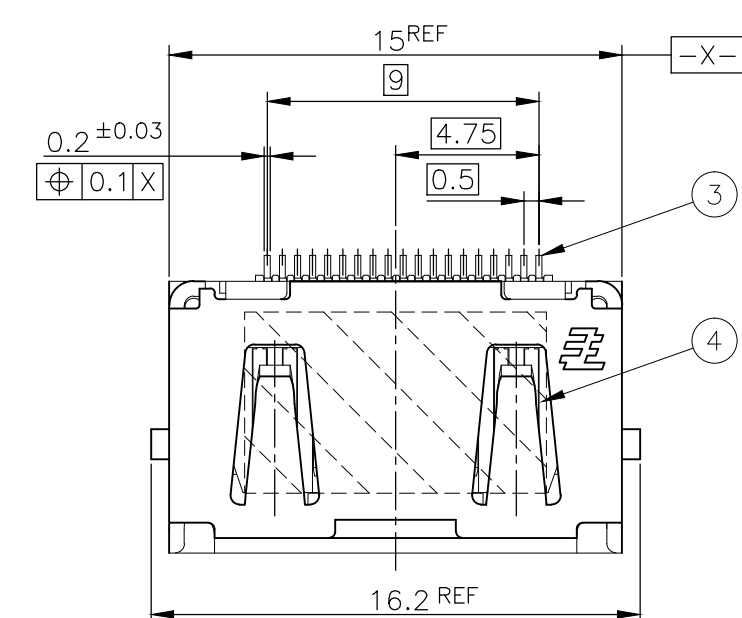

PANEL CUT OUT DIMENSION (REFERENCE)

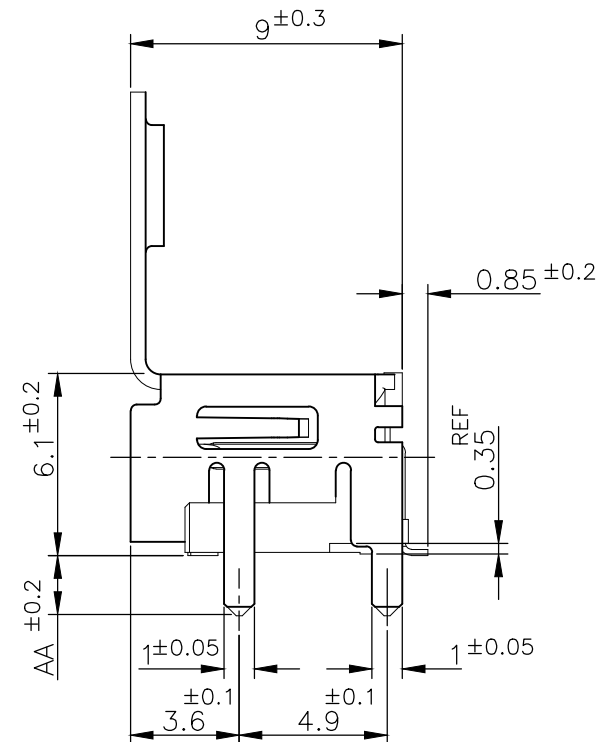
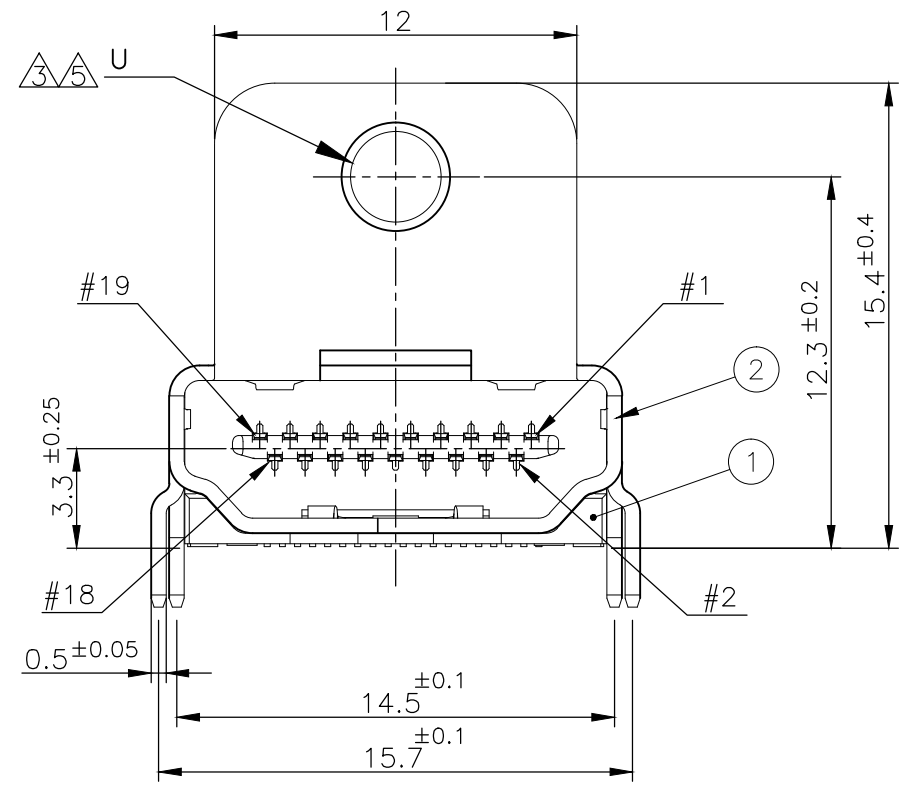

CONNECTOR: WITH FLANGE THROUGH HOLE TYPE

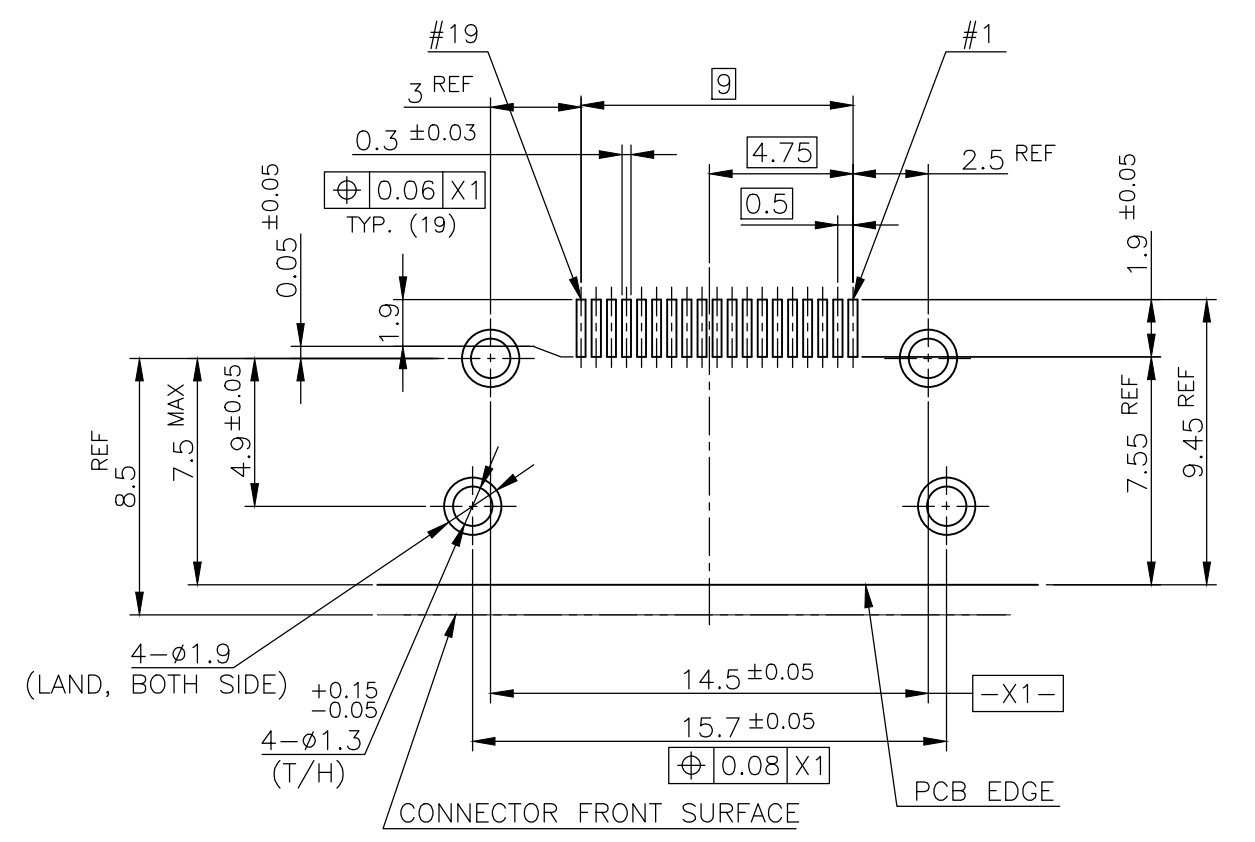

P.C.B LAYOUT (REFERENCE)
SHOWN AS CONNECTOR MOUNTING SIDE
TOLERANCE: NON-CUMULATIVE

POLYIMIDE	TAPE	(4)
BRASS	CONTACT	(3)
PHOSPHOR BRONZE	SHELL	(2)
GLASS FILLED LCP UL94V-0, BLACK COLOR	HOUSING	(1)
MATERIAL	DESCRIPTION	ITEM

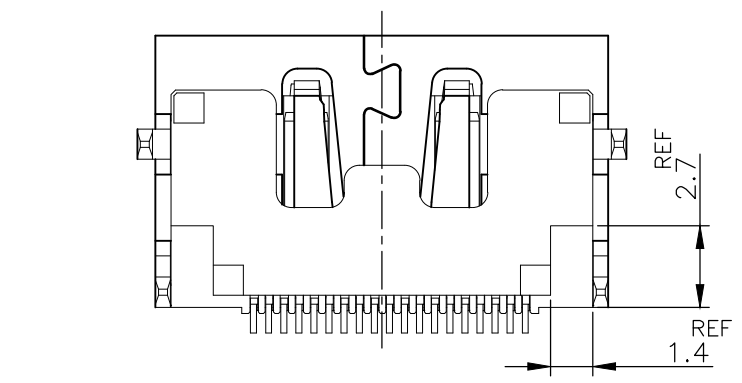

THIS DRAWING IS A CONTROLLED DOCUMENT.		DWN	TE Connectivity	
DIMENSIONS: 單位: 耗 mm		CHK		
TOLERANCES UNLESS OTHERWISE SPECIFIED: 一般公差		APVD		
0 PLC ± 1 PLC ± 2 PLC ± 3 PLC ± 4 PLC ± ANGLES ±		NAME 名称		
MATERIAL 材料		WEIGHT	HDMI 19 POS RECEPTACLE ASSY SMT SHORT TYPE	
FINISH 仕上		CUSTOMER DRAWING	SIZE	RESTRICTED TO
			A3	
			CAGE CODE	
			DRAWING NO	
			G-1903015	
			SCALE 尺度 4:1	
			SHEET 3 OF 12	
			REV S	

THIS DRAWING IS UNPUBLISHED. RELEASED FOR PUBLICATION SEP, 2005.
 © COPYRIGHT 2005 By - ALL RIGHTS RESERVED.

LOC	DIST	REVISIONS			DATE	DWN	APVD
		P	LTR	DESCRIPTION			
-	-	-	-	SEE SHEET 1	-	-	-

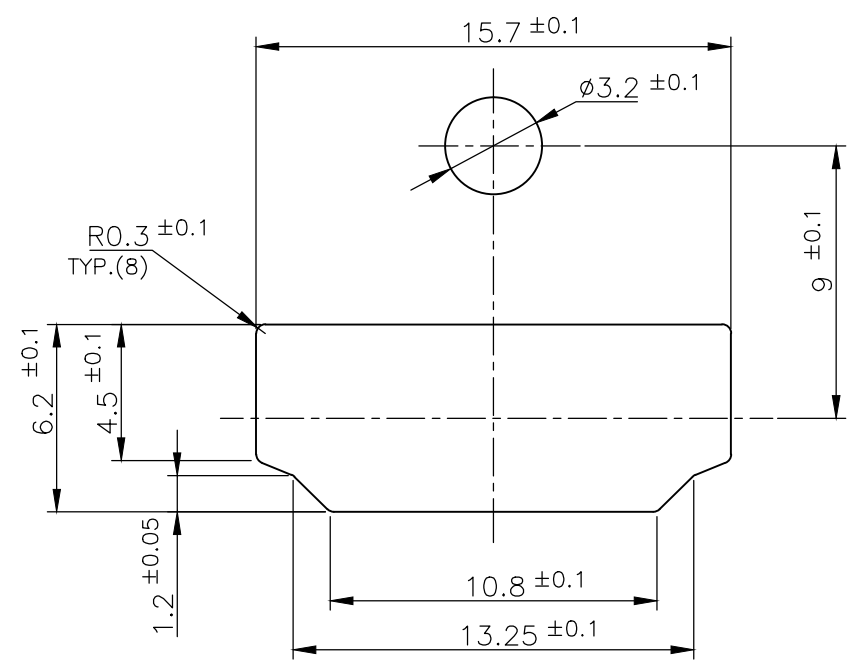
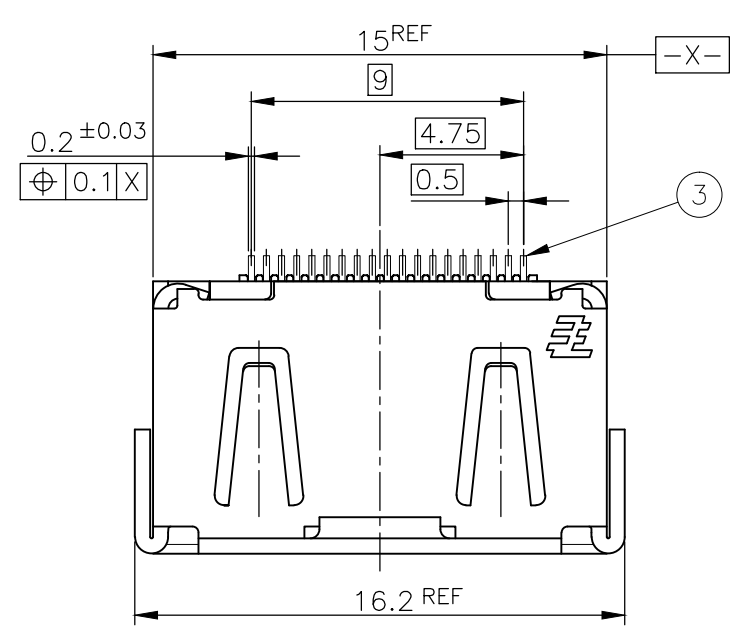

PANEL CUT OUT DIMENSION (REFERENCE)

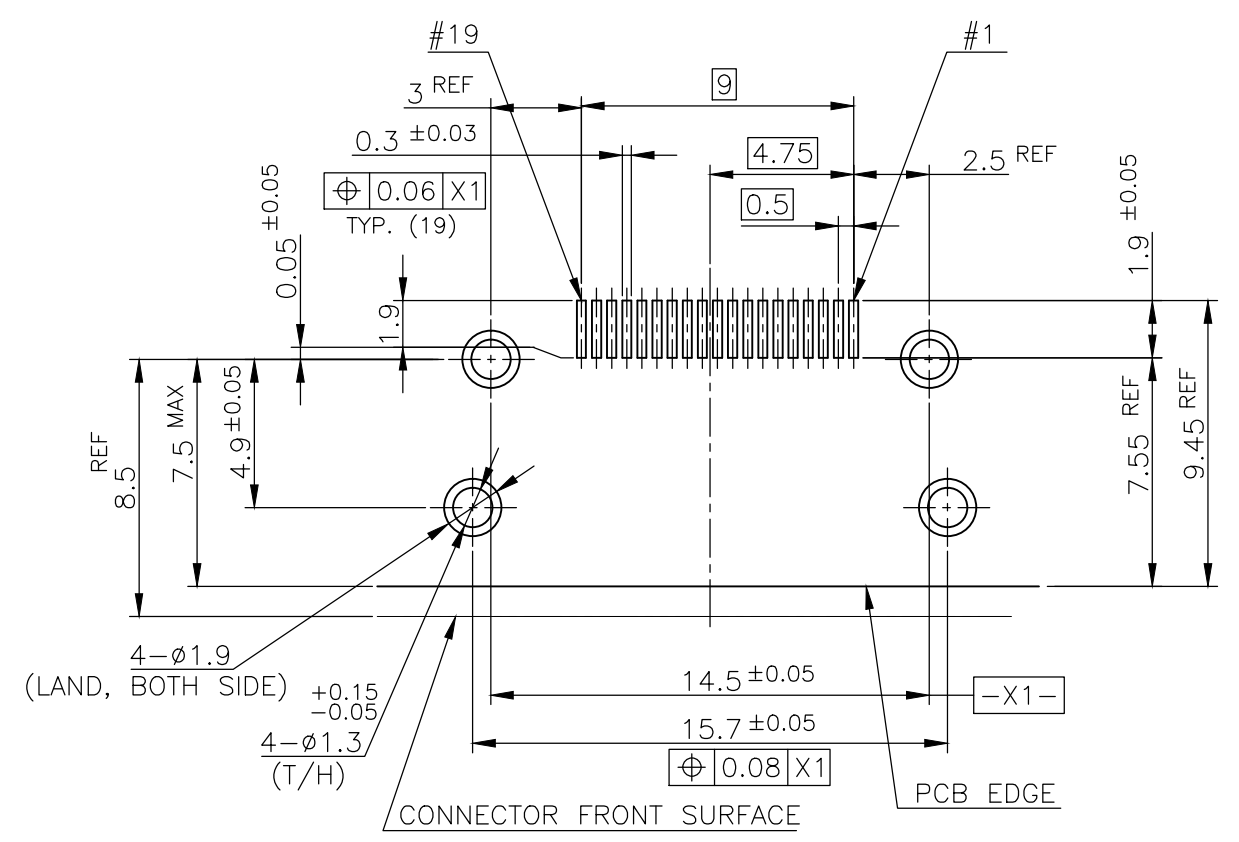

P.C.B LAYOUT (REFERENCE)
 SHOWN AS CONNECTOR MOUNTING SIDE
 TOLERANCE: NON-CUMULATIVE

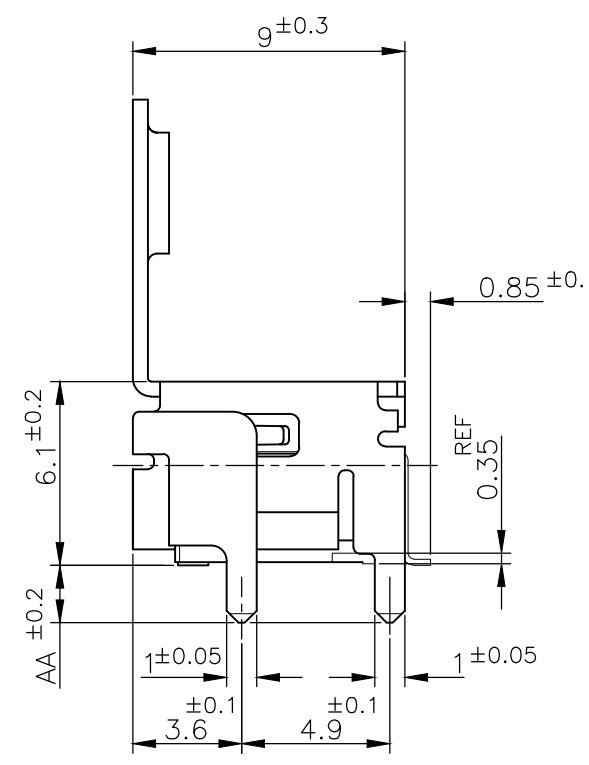
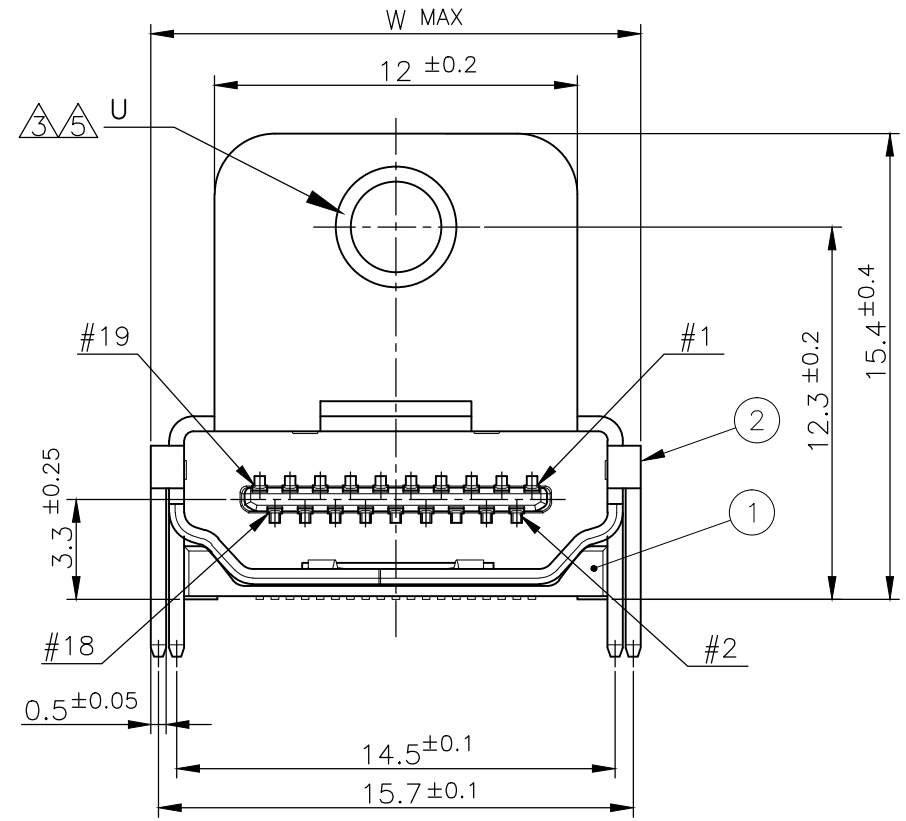

CONNECTOR: WITH FLANGE THROUGH HOLE TYPE

POLYIMIDE	TAPE	④
BRASS	CONTACT	③
PHOSPHOR BRONZE	SHELL	②
GLASS FILLED LCP UL94V-0, BLACK COLOR	HOUSING	①
MATERIAL	DESCRIPTION	ITEM

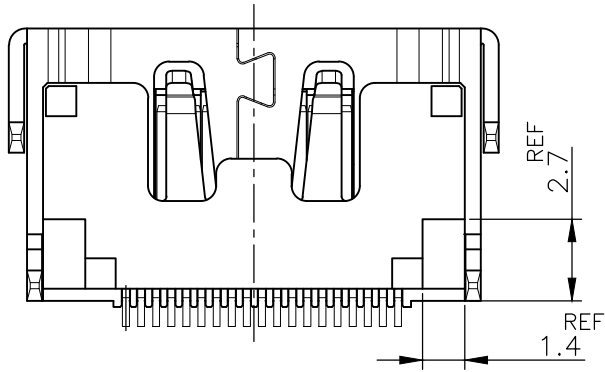

THIS DRAWING IS A CONTROLLED DOCUMENT.		DWN	TE Connectivity NAME 名称 HDMI 19 POS RECEPTACLE ASSY SMT SHORT TYPE				
DIMENSIONS: 单位: 耗 mm		CHK					
TOLERANCES UNLESS OTHERWISE SPECIFIED: 一般公差		APVD					
0 PLC ± 1 PLC ± 2 PLC ± 3 PLC ± 4 PLC ± ANGLES ±		PRODUCT SPEC 製品規格					
MATERIAL 材料		FINISH 仕上	APPLICATION SPEC 取付適用規格	SIZE	CAGE CODE	DRAWING NO 番号	RESTRICTED TO
		WEIGHT	CUSTOMER DRAWING	A3	00779	G-1903015	-
				SCALE 尺度	4:1	SHEET	4 OF 12
						REV	S

THIS DRAWING IS UNPUBLISHED. RELEASED FOR PUBLICATION SEP , 2005.
 © COPYRIGHT 2005 By - ALL RIGHTS RESERVED.

LOC	DIST	REVISIONS			
		变更	DATE	DWN	APVD
		P	LTR	DESCRIPTION	
		-	-	SEE SHEET 1	-

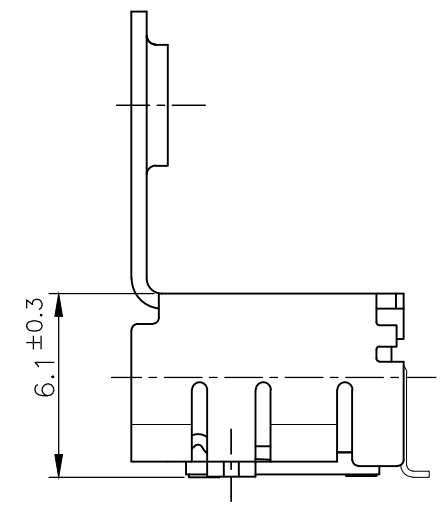
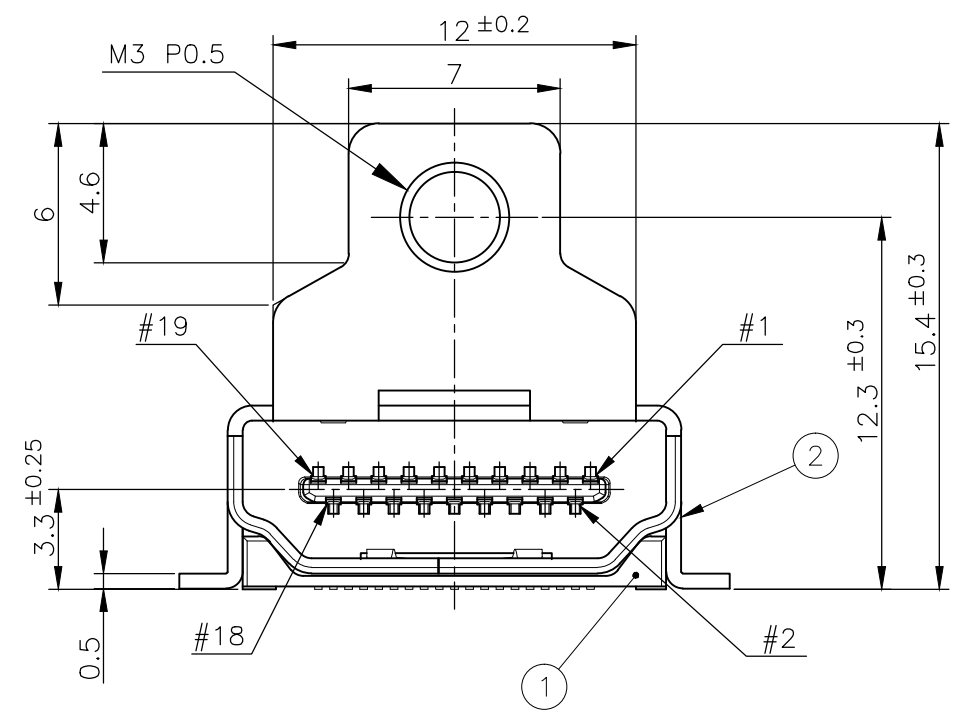
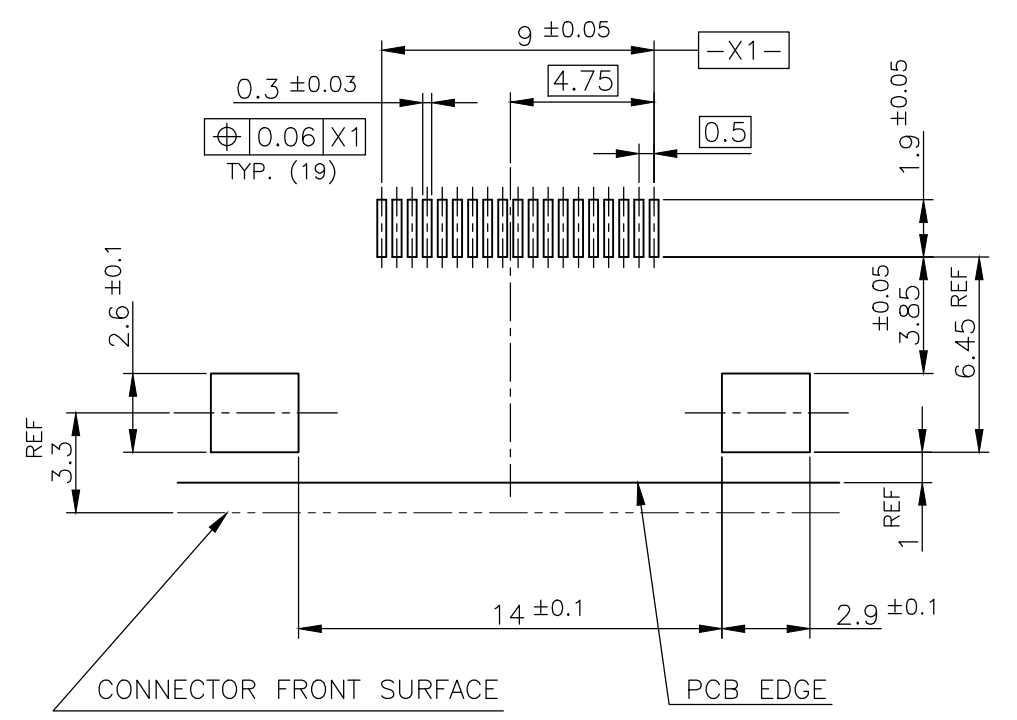
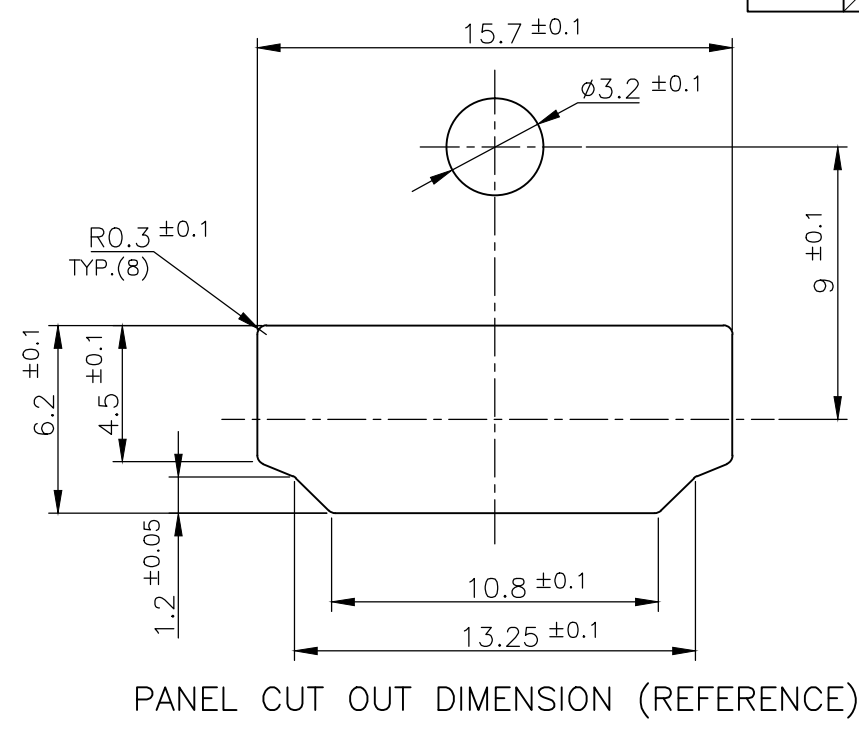
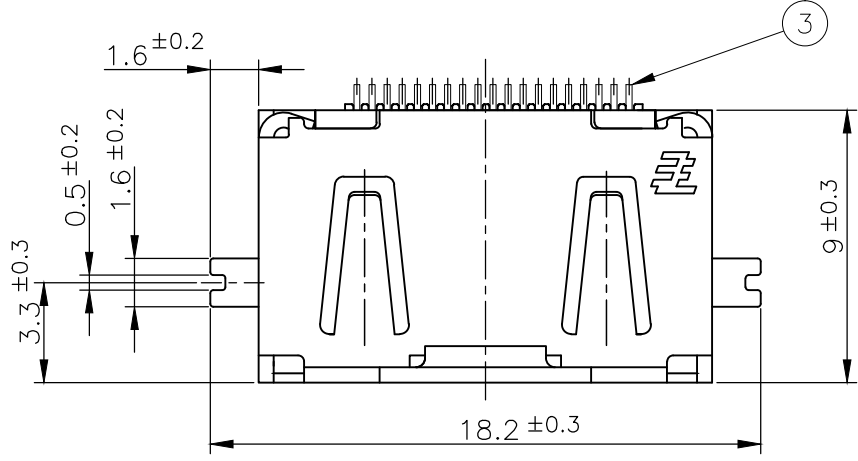

CONNECTOR: WITH FLANGE FULL SMT TYPE

BRASS	CONTACT	3
PHOSPHOR BRONZE	SHELL	2
GLASS FILLED LCP UL94V-0, BLACK COLOR	HOUSING	1
MATERIAL	DESCRIPTION	ITEM

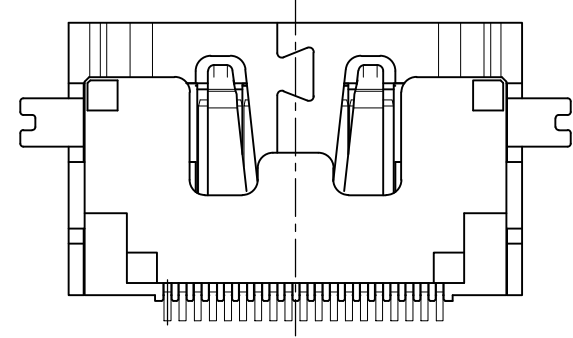

THIS DRAWING IS A CONTROLLED DOCUMENT.		DWN	TE Connectivity					
DIMENSIONS: 单位: 耗 mm		CHK				NAME 名称		
TOLERANCES UNLESS OTHERWISE SPECIFIED: 一般公差		APVD				HDMI 19 POS RECEPTACLE ASSY SMT SHORT TYPE		
0 PLC ± 1 PLC ± 2 PLC ± 3 PLC ± 4 PLC ± ANGLES ±		PRODUCT SPEC 製品規格				SIZE	CAGE CODE	DRAWING NO 番号
MATERIAL 材料		FINISH 仕上	RESTRICTED TO					
		WEIGHT	A300779 C-1903015					
		CUSTOMER DRAWING	SCALE 尺度 4:1	SHEET 5 OF 12	REV S			

THIS DRAWING IS UNPUBLISHED.

RELEASED FOR PUBLICATION

SEP ,2005.

© COPYRIGHT 2005 By -

ALL RIGHTS RESERVED.

1903015-1, 2-1903015-2, 5-1903015-1
5-1903015-5, 7-1903015-1; AS SHOWN

LOC	DIST
-	-

REVISIONS			DATE	DWN	APVD
P	LTR	DESCRIPTION			
-	-	SEE SHEET 1	-	-	-

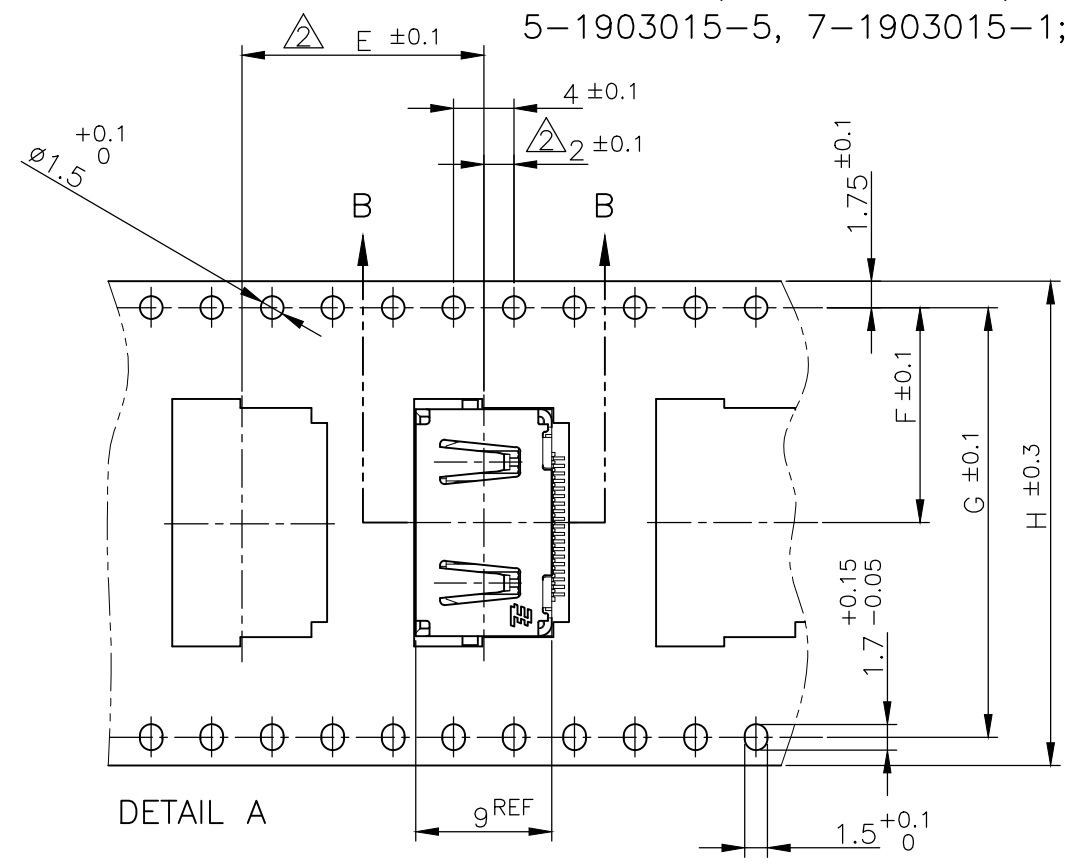

5-1903015-3; AS SHOWN (SCALE 1:1)

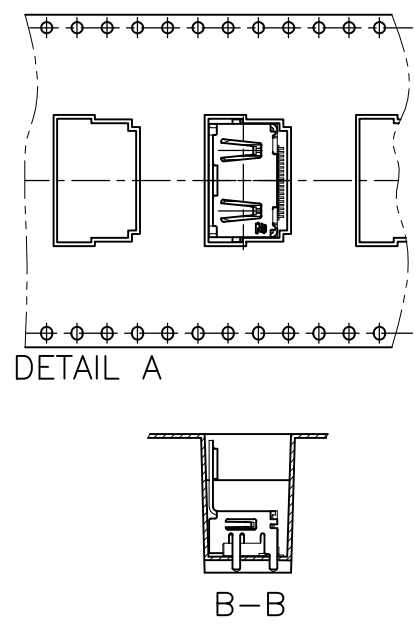

5-1903015-9; AS SHOWN (SCALE 1:1)

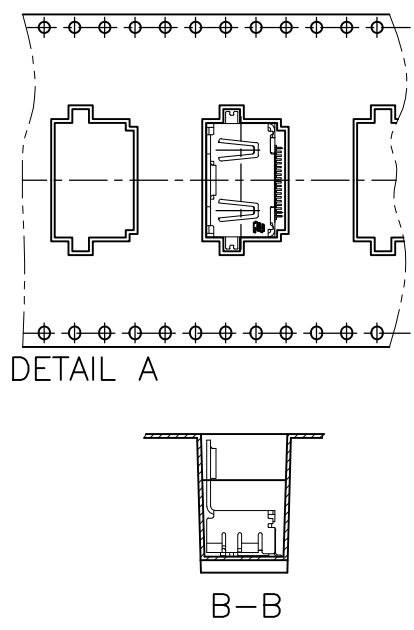

9-1903015-3; AS SHOWN (SCALE 1:1)

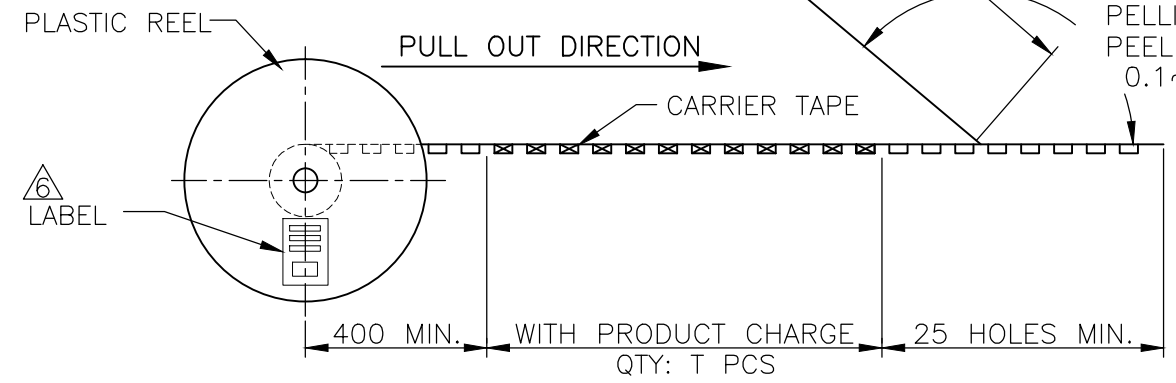
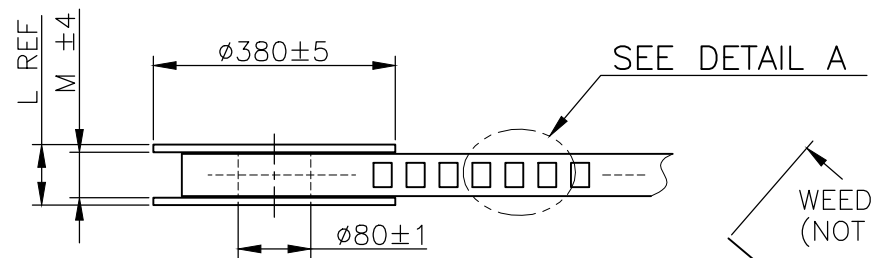
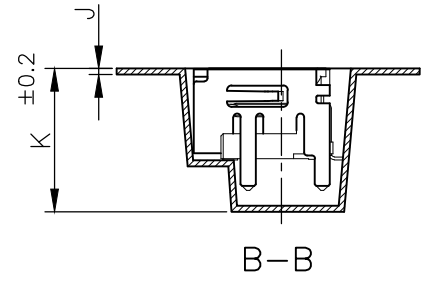
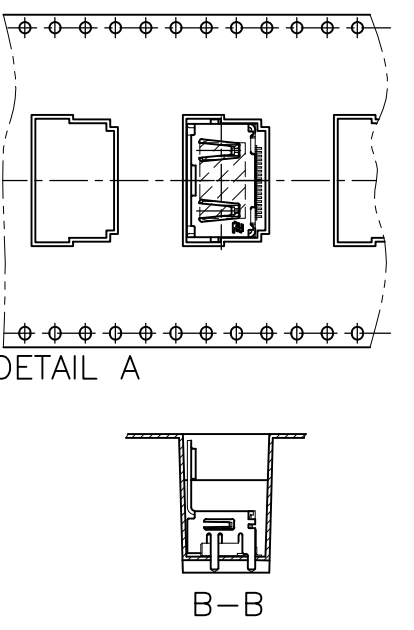

WEEDING THE COVER TAPE: 300 MIN (NOT INCLUDE EMPTINESS POCKET)

PELLING ANGLE: 165°~180°
PEELING STRENGTH: 0.1~0.7N (300mm/min.)

△ LABEL DESCRIPTION

TYCO P/N: *-1903015-*
QTY: * pcs
D/C: MADE IN CHINA

1903015-3; AS SHOWN (SCALE 1:1)

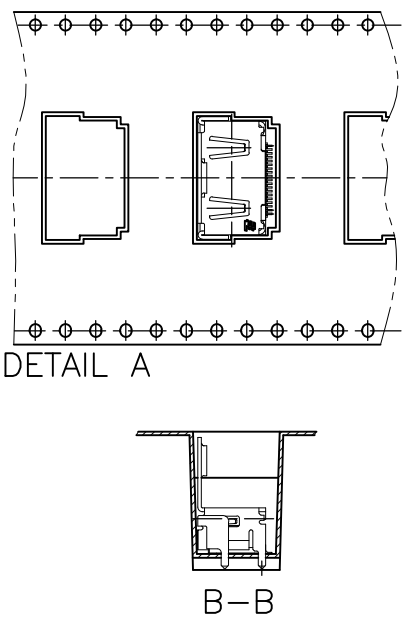

PET	COVER TAPE
PS	CARRIER TAPE
PLASTIC	REEL
MATERIAL	DESCRIPTION

THIS DRAWING IS A CONTROLLED DOCUMENT.

DIMENSIONS: 單位: 耗 mm	TOLERANCES UNLESS OTHERWISE SPECIFIED: 一般公差
0 PLC	±
1 PLC	±
2 PLC	±
3 PLC	±
4 PLC	±
ANGLES	±
FINISH 仕上	

MATERIAL 材料

DWN	CHK	APVD
PRODUCT SPEC 製品規格	APPLICATION SPEC 取付適用規格	WEIGHT

STE TE Connectivity

NAME 名称: HDMI 19 POS RECEPTACLE ASSY SMT SHORT TYPE

SIZE: A3 CAGE CODE: 00779 DRAWING NO: G-1903015

RESTRICTED TO: -

CUSTOMER DRAWING SCALE 尺度: 4:1 SHEET 6 OF 12 REV S

THIS DRAWING IS UNPUBLISHED. RELEASED FOR PUBLICATION SEP , 2005.
 © COPYRIGHT 2005 By - ALL RIGHTS RESERVED.

LOC	DIST	REVISIONS			DATE	DWN	APVD
		P	LTR	DESCRIPTION			
-	-	-	-	SEE SHEET 1	-	-	-

1903015-4; AS SHOWN

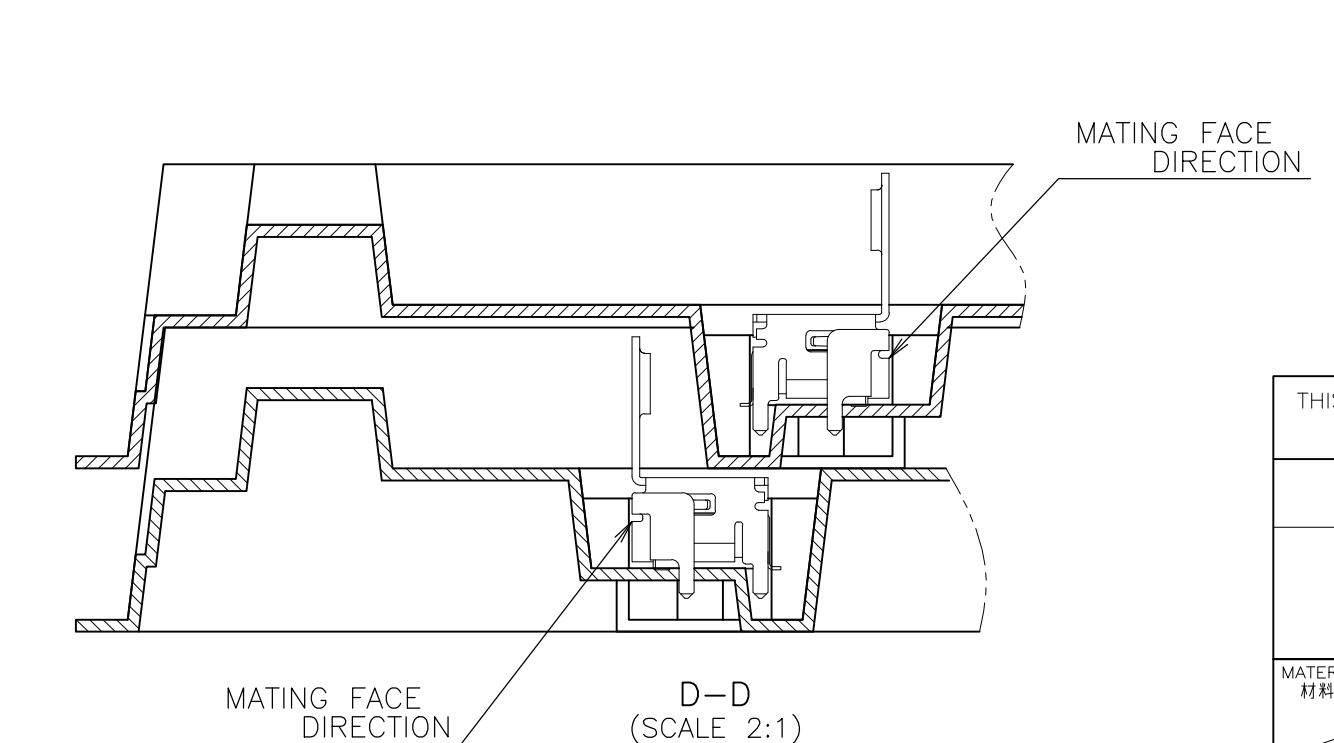
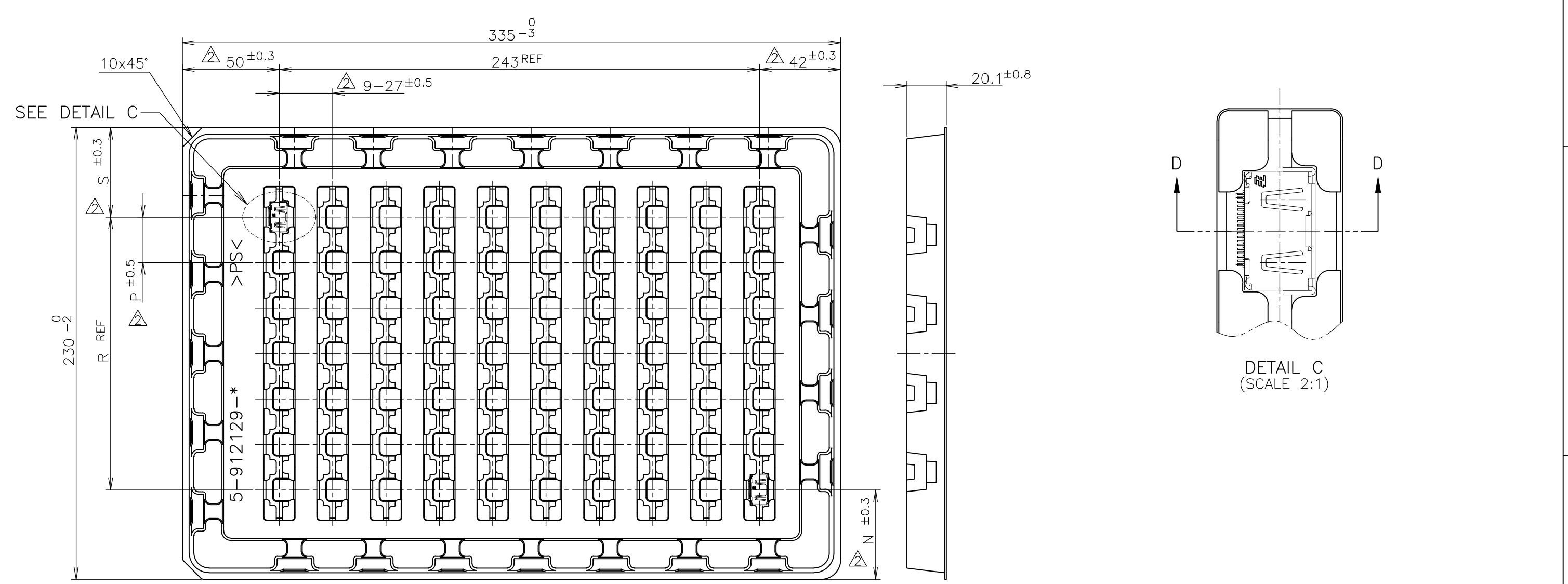

THIS DRAWING IS A CONTROLLED DOCUMENT.		DWN	TE Connectivity NAME 名称 HDMI 19 POS RECEPTACLE ASSY SMT SHORT TYPE				
DIMENSIONS: 单位: 耗 mm		CHK					
TOLERANCES UNLESS OTHERWISE SPECIFIED: 一般公差		APVD					
0 PLC ± 1 PLC ± 2 PLC ± 3 PLC ± 4 PLC ± ANGLES ±		PRODUCT SPEC 製品規格					
MATERIAL 材料		WEIGHT	APPLICATION SPEC 取付適用規格	SIZE A3	CAGE CODE 00779	DRAWING NO 番号 C-1903015	RESTRICTED TO
CUSTOMER DRAWING			SCALE 尺度 4:1	SHEET 8 OF 12	REV S		

LOC	DIST
-	-

REVISIONS		DATE	DWN	APVD
P	LTR	DESCRIPTION		
-	-	SEE SHEET 1	-	-

8-1903015-4; AS SHOWN

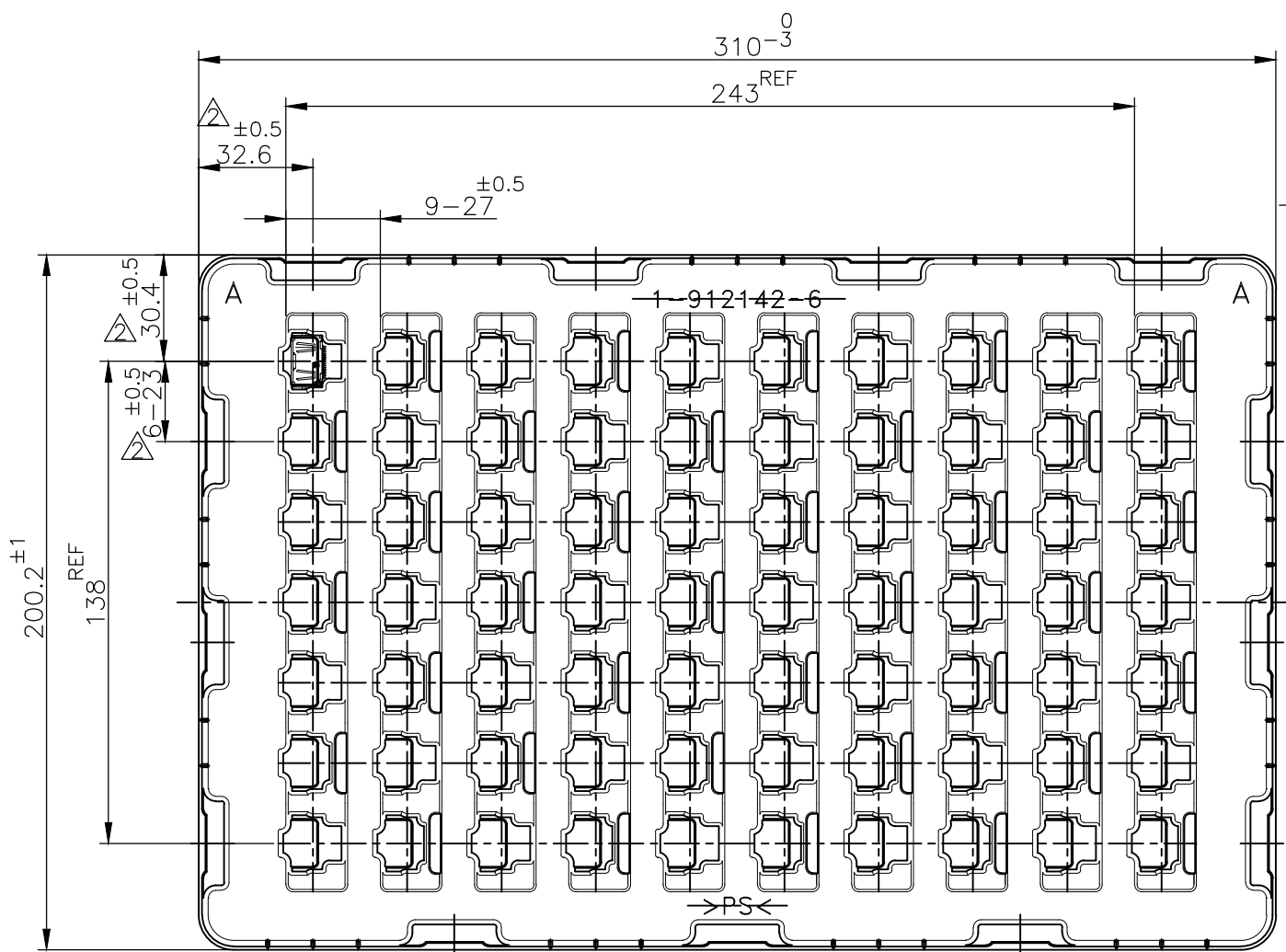

TRAY A

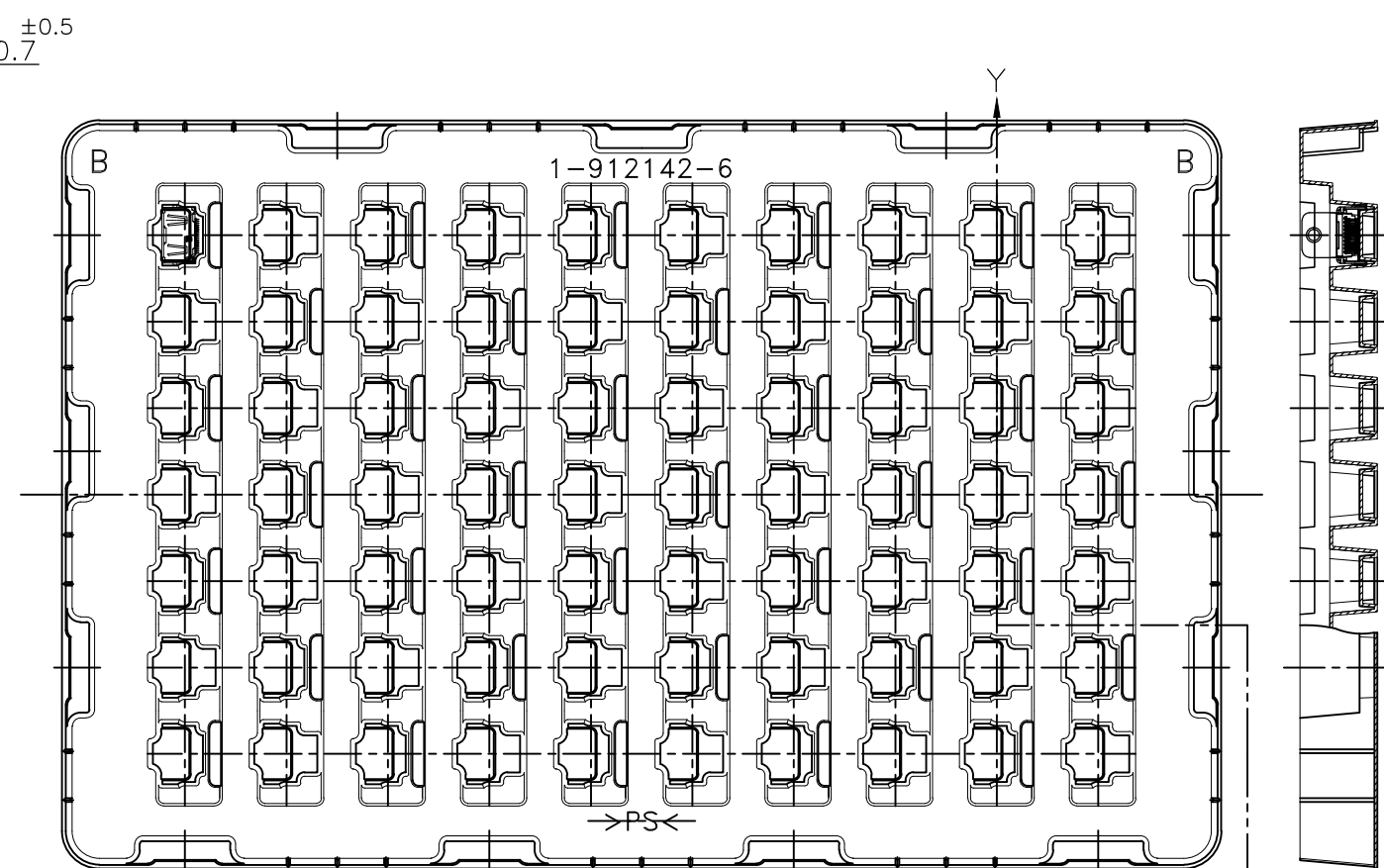

TRAY B

TRAY B (EMPTY)

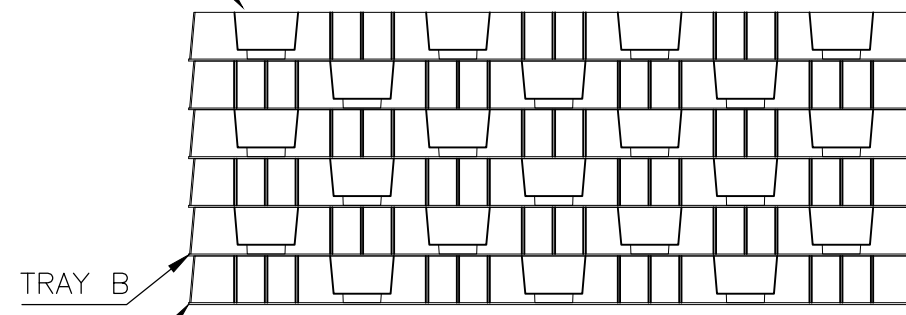

TRAY B

TRAY A

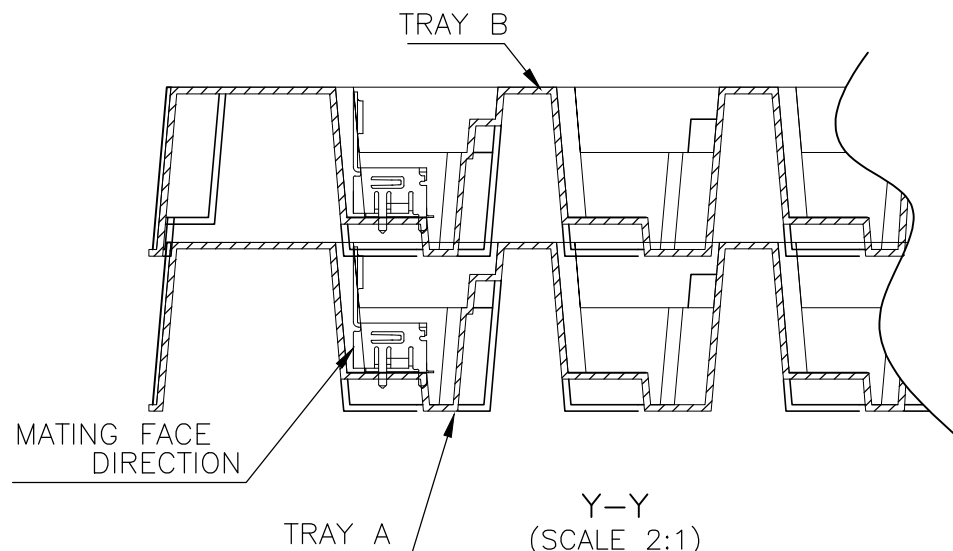

Y-Y (SCALE 2:1)

PS	TRAY
MATERIAL	DESCRIPTION

THIS DRAWING IS A CONTROLLED DOCUMENT.		DWN	STE TE Connectivity	
DIMENSIONS: 單位: 耗 mm		CHK		
TOLERANCES UNLESS OTHERWISE SPECIFIED: 一般公差		APVD	NAME 名称	
0 PLC ±		PRODUCT SPEC 製品規格	HDMI 19 POS RECEPTACLE ASSY	
1 PLC ±		APPLICATION SPEC 取付適用規格	SMT SHORT TYPE	
2 PLC ±		WEIGHT	SIZE	CAGE CODE
3 PLC ±		CUSTOMER DRAWING	A3	00779
4 PLC ±			DRAWING NO 番号	G-1903015
ANGLES ±		SCALE 尺度	4:1	SHEET 10 OF 12
FINISH 仕上		RESTRICTED TO	REV S	

4

3

2

1

THIS DRAWING IS UNPUBLISHED. RELEASED FOR PUBLICATION SEP , 2005.
 © COPYRIGHT 2005 By - ALL RIGHTS RESERVED.

LOC		DIST		REVISIONS 変更			DATE	DWN	APVD
P	LTR	DESCRIPTION							
-	-	SEE SHEET 1			-	-	-	-	

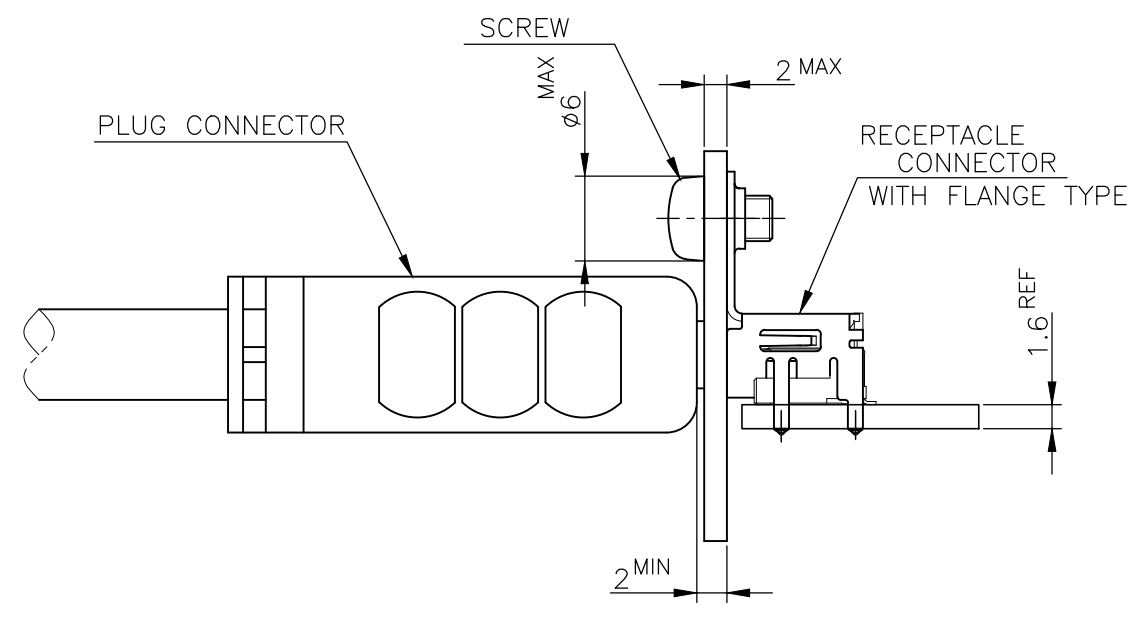
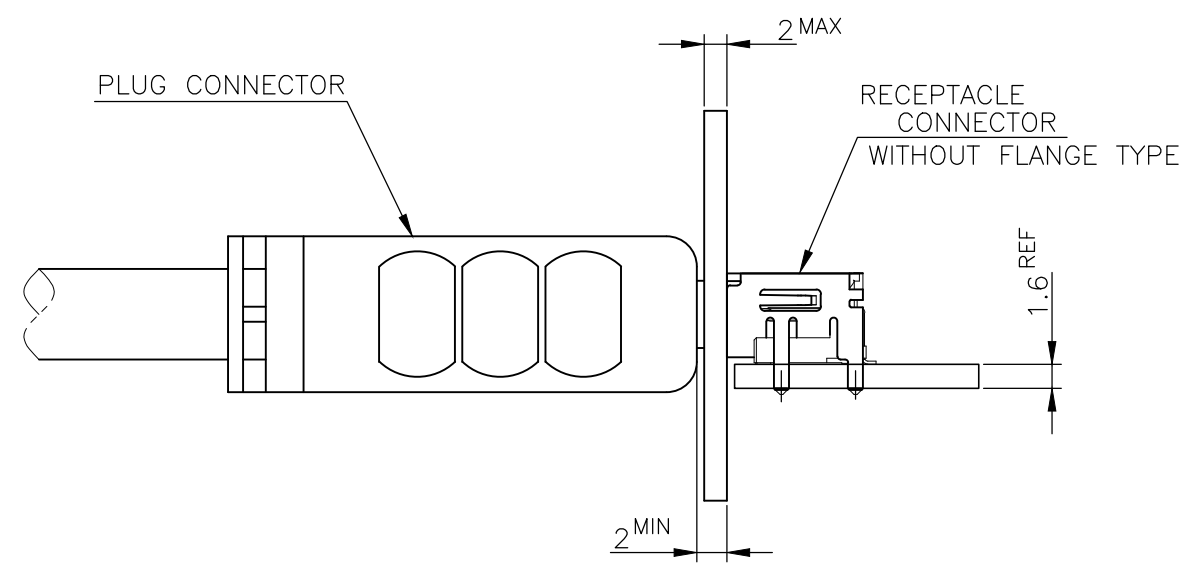

MATING CONDITION (REFERENCE)
 (SCALE 2:1)

THIS DRAWING IS A CONTROLLED DOCUMENT.		DWN		STE TE Connectivity	
DIMENSIONS: 單位: 耗 mm		CHK			
		APVD		NAME 名稱	
		PRODUCT SPEC 製品規格		HDMI 19 POS RECEPTACLE ASSY SMT SHORT TYPE	
MATERIAL 材料		WEIGHT		SIZE	CAGE CODE
FINISH 仕上		CUSTOMER DRAWING		DRAWING NO 番号	RESTRICTED TO
TOLERANCES UNLESS OTHERWISE SPECIFIED: 一般公差		SCALE 尺度		SHEET	
0 PLC ±	4:1		11 OF 12		REV
1 PLC ±	SHEET		REV		S
2 PLC ±	SCALE		REV		S
3 PLC ±	SHEET		REV		S
4 PLC ±	SCALE		REV		S
ANGLES ±	SHEET		REV		S

THIS DRAWING IS UNPUBLISHED. RELEASED FOR PUBLICATION SEP, 2005.
 ALL RIGHTS RESERVED.

LOC	DIST	P	LTR	REV	DATE	DWN	APVD
-	-	-	-	SEE SHEET 1	-	-	-

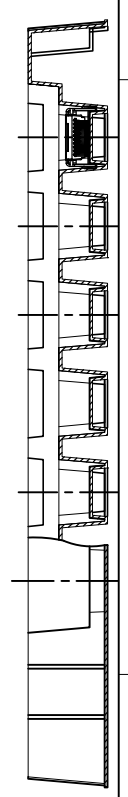
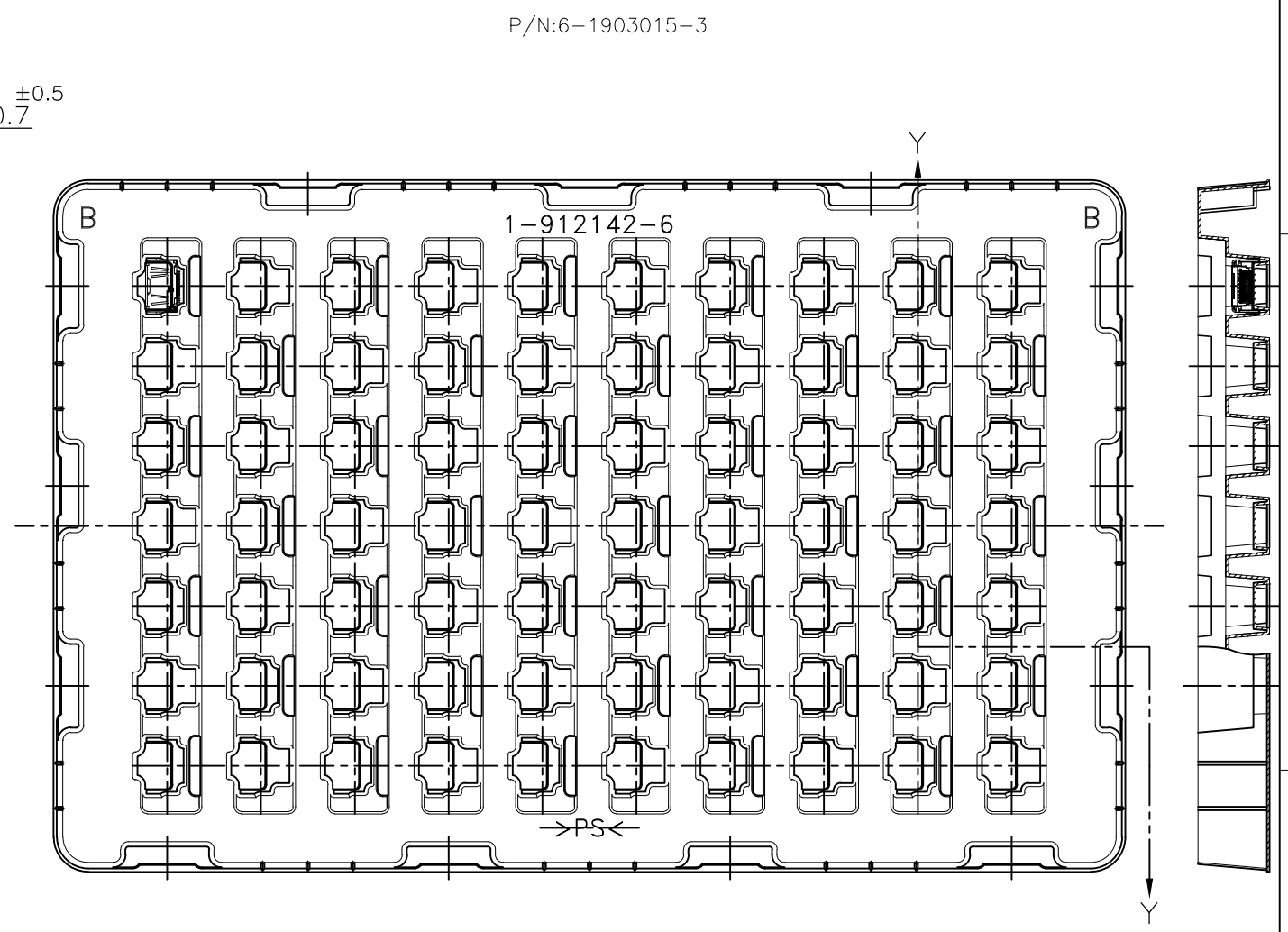
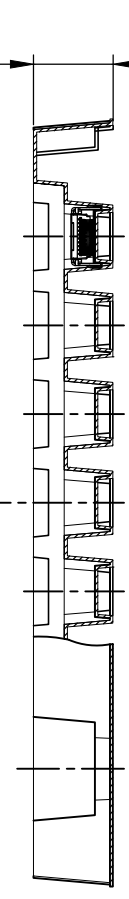
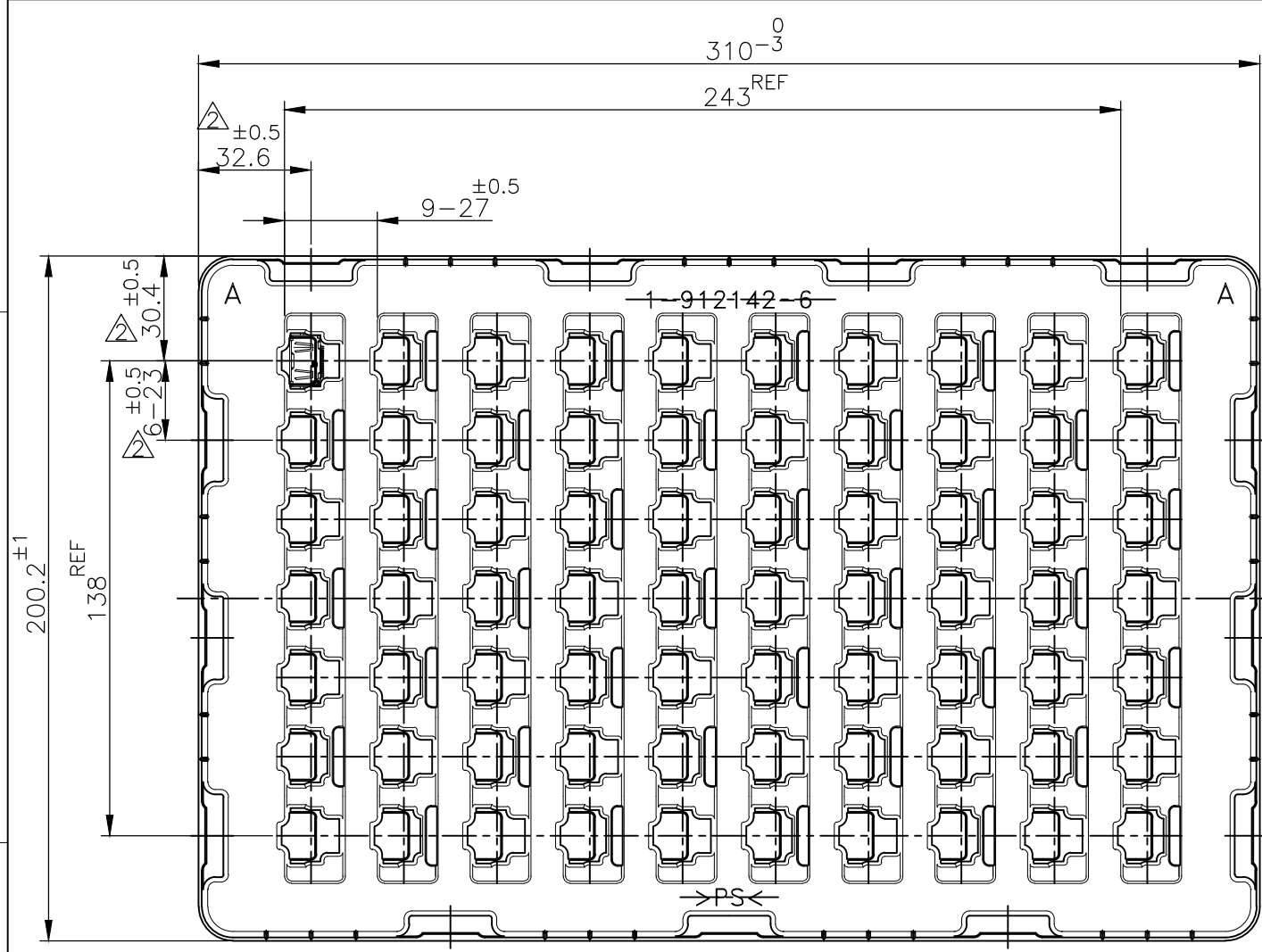

P/N:6-1903015-3

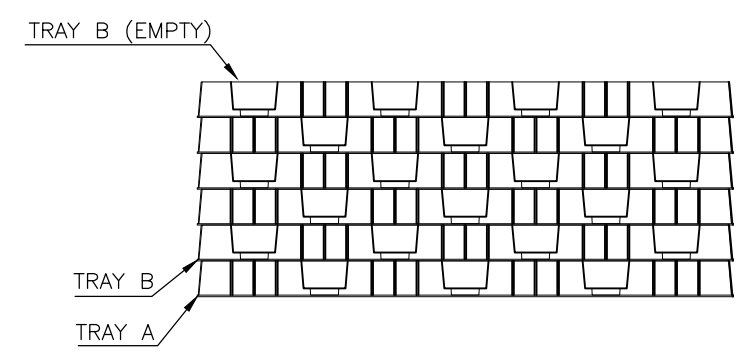
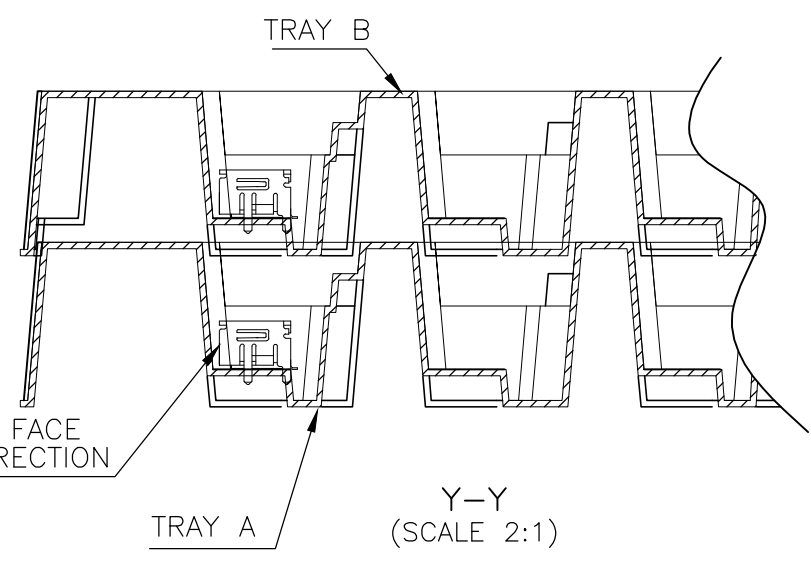

PS	TRAY
MATERIAL	DESCRIPTION

THIS DRAWING IS A CONTROLLED DOCUMENT.		DWN	TE Connectivity NAME HDMI 19 POS RECEPTACLE ASSY SMT SHORT TYPE			RESTRICTED TO
DIMENSIONS: 單位: 耗 mm		CHK				
TOLERANCES UNLESS OTHERWISE SPECIFIED: 一般公差		APVD				
0 PLC ± 1 PLC ± 2 PLC ± 3 PLC ± 4 PLC ± ANGLES ±		PRODUCT SPEC 製品規格				
MATERIAL 材料		FINISH 仕上	APPLICATION SPEC 取付適用規格	SIZE	CAGE CODE	DRAWING NO 番号
			WEIGHT	A3	00779	G-1903015
CUSTOMER DRAWING			SCALE 尺度 4:1	SHEET 12 OF 12	REV S	

Looking for pricing, stock, or lifecycle information?

Click below to explore more details on WIN SOURCE:

- [View 5-1903015-1 on WIN SOURCE](#)
- [TE Connectivity Information](#)

Optimize Your Supply Chain with WIN SOURCE Solutions

- ✓ Global Sourcing Solution
- ✓ Obsolete Management
- ✓ Cost Control Management
- ✓ Shortage Management
- ✓ Alternative Solution
- ✓ Excess Inventory Management