



THE DATASHEET OF
5-1612773-1



THIS DRAWING IS UNPUBLISHED. RELEASED FOR PUBLICATION JUL ,2002.
 © COPYRIGHT 2002 By - ALL RIGHTS RESERVED.

LOC	DIST	REVISIONS			
P	LTR	DESCRIPTION	DATE	DWN	APVD
J		G2	REVISED PER ECO-11-005033	29MAR11	RK HMR

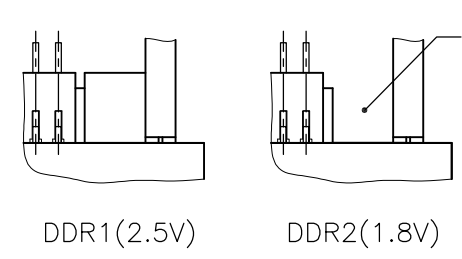
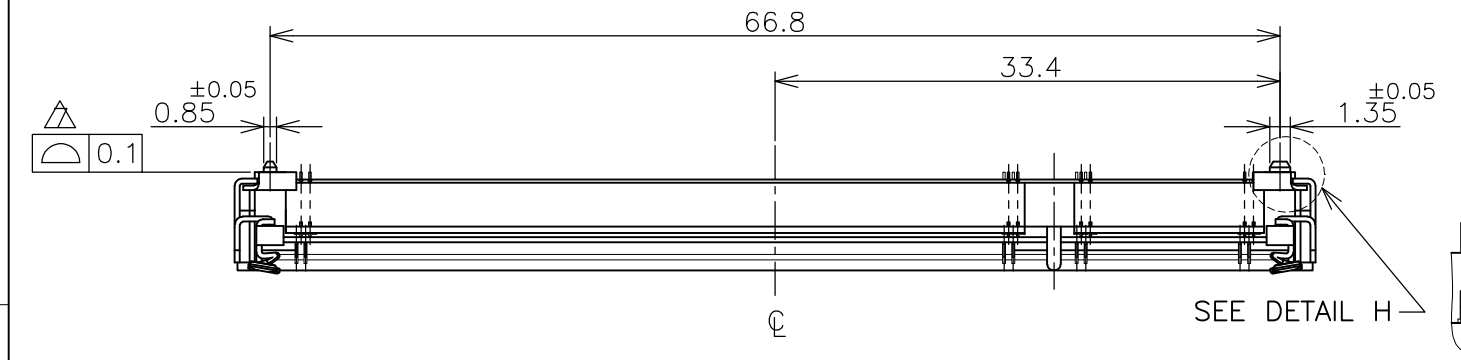

HOW TO MATE AND UNMATE
 MATE: ① → ④
 UNMATE: ⑤ → ⑦

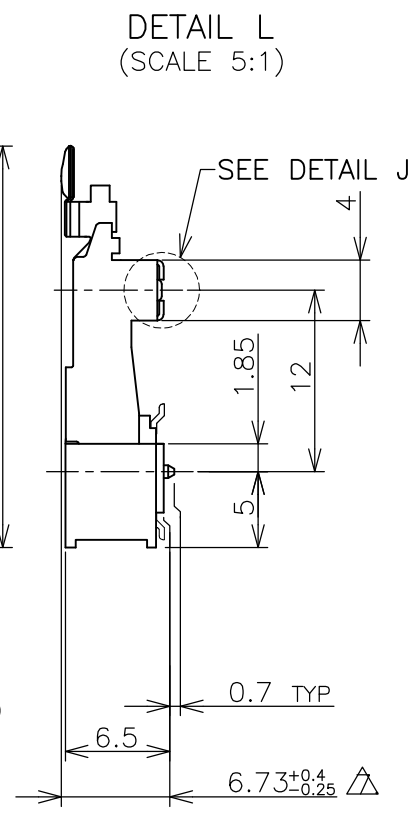
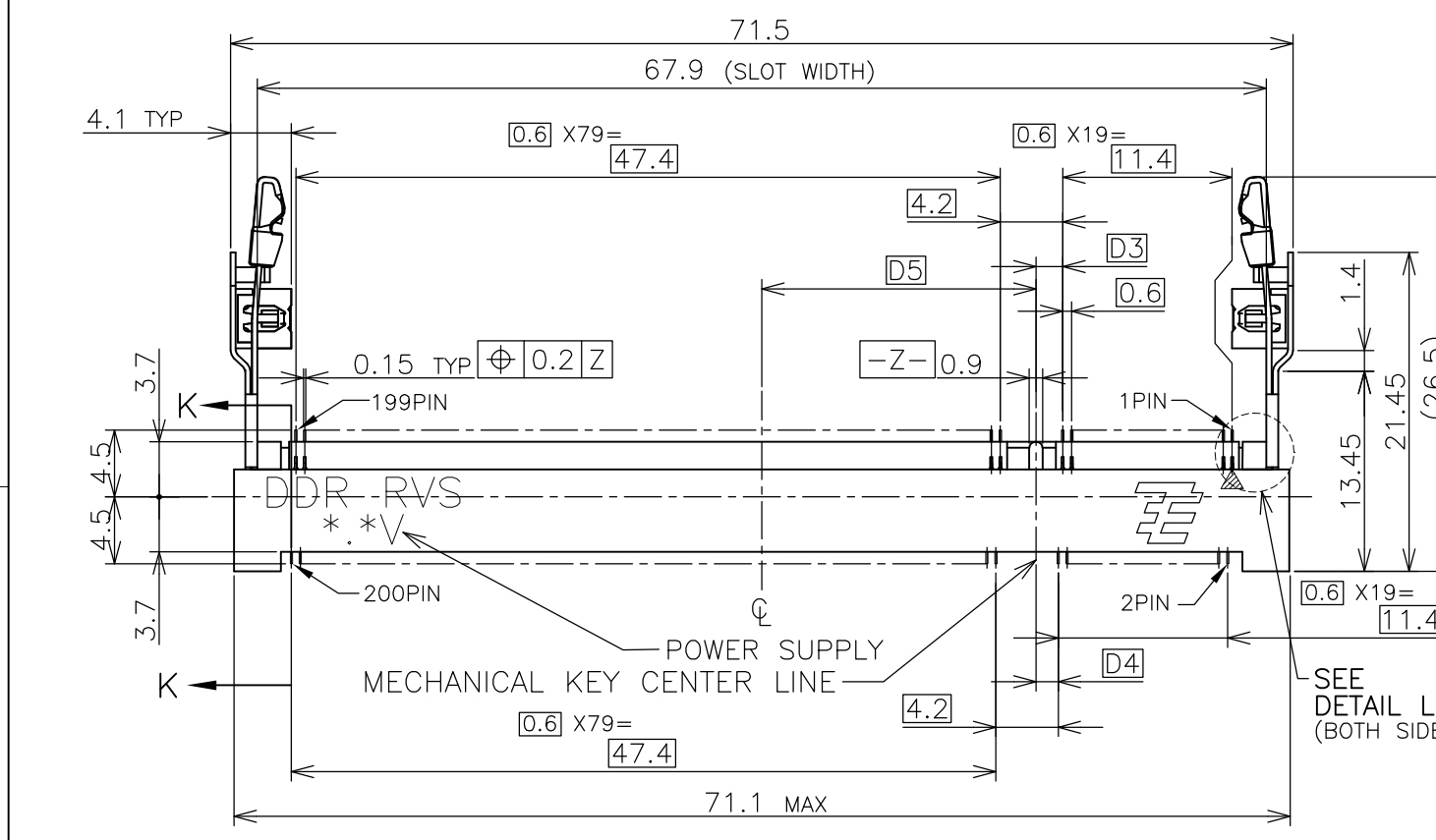
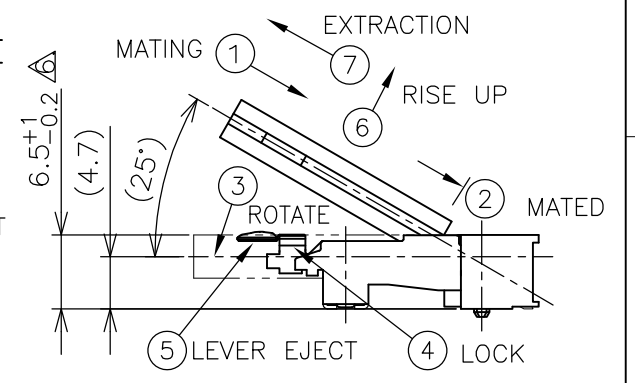

- (APPLIED TO SHEET 1-2)
- MATERIAL; HOUSING: HIGH TEMPERATURE THERMO PLASTIC UL94V-0
 CONTACT: COPPER ARROY
 LOCK LEVER: STAINLESS STEEL
 SOLDER PEG: COPPER ARROY
 - FINISH; CONTACT AREA: GOLD FLASH ON 0.0013 MIN ALL OVER NICKEL.
 SOLDERING AREA: GOLD FLASH PLT.
 SOLDER PEG: TIN PLATING.
- MECHANICAL KEY POSITION OF CONNECTOR SEE TABLE.
 - TOLERANCES NON-CUMULATIVE.
 - NOT TO SCALE.
 - INSIDE MUST BE RESIST COAT EXCEPT SOLDER PATTERN.
 - COPLANARITY: 0.1 MAX.
 - THE FLOATING VALUE BY SOLDERING IS NOT INCLUDED.
 - NOT MATING CONDITION.
- 10 IF THE MODULE DOESN'T INSERT AND LOCK IN THE LATCH SMOOTHLY, OPEN WIDE BOTH LATCHES BY MANUAL. AND THE MODULE MUST BE INSERTED AND LOCKED IN THE LATCH.

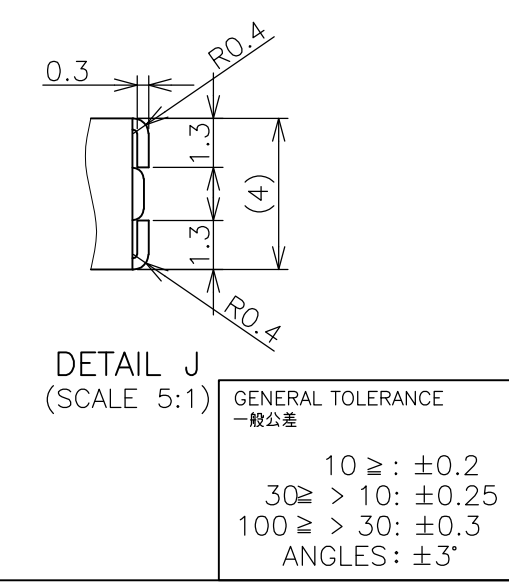
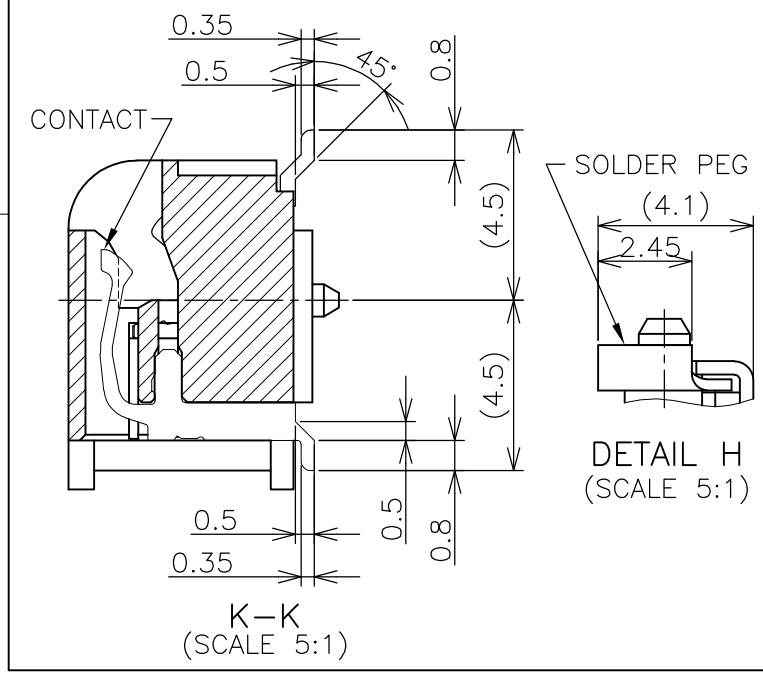

AVAILABLE	HOUSING COLOR: GRAY	1.8V (DDR2)	17.55	2.4	2.7	200	5-1612773-4
AVAILABLE	HOUSING COLOR: BLACK BOSSLESS	1.8V (DDR2)	17.55	2.4	2.7	200	1-1612773-4
AVAILABLE	HOUSING COLOR: BLACK	1.8V (DDR2)	17.55	2.4	2.7	200	1612773-4
AVAILABLE	HOUSING COLOR: GRAY	2.5V (DDR1)	18.45	1.5	1.8	200	5-1612773-1
NOT AVAILABLE	HOUSING COLOR: BLACK	2.5V (DDR1)	18.45	1.5	1.8	200	1612773-1
TOOLING STATUS	REMARK	POWER SUPPLY (TYPE)	D5	D4	D3	POS	PART NO.
THIS DRAWING IS A CONTROLLED DOCUMENT.		DWN B.WONG	20JUL10	TE Connectivity DDR1 & DDR2 SODIMM SOCKET 0.6mm PITCH 200POS 6.5 HEIGHT REVERSE TYPE			
DIMENSIONS: mm		CHK C.WANG	20JUL10				
TOLERANCES UNLESS OTHERWISE SPECIFIED:		APVD S.YAO	20JUL10				
0 PLC ± 1 PLC ± 2 PLC ± 3 PLC ± 4 PLC ± ANGLES ± FINISH ±		PRODUCT SPEC	NAME				
MATERIAL		108-5701	APPLICATION SPEC	SIZE	CAGE CODE	DRAWING NO	RESTRICTED TO
		WEIGHT	5.7g	A3	00779	C-1612773	
CUSTOMER DRAWING				SCALE	2:1	SHEET	1 OF 4
				REV	G2		

THIS DRAWING IS UNPUBLISHED. RELEASED FOR PUBLICATION JUL ,2002.
 © COPYRIGHT 2002 By - ALL RIGHTS RESERVED.

LOC	DIST	REVISIONS					
J		P	LTR	DESCRIPTION	DATE	DWN	APVD
		-		SEE SHEET 1	-	-	-

REFERENCE P.C. BOARD PATTERN LAYOUT (CONNECTOR MOUNTING SIDE)

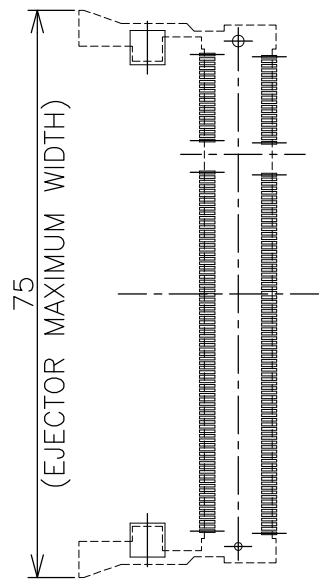

REAL SIZE (SCALE 1:1)

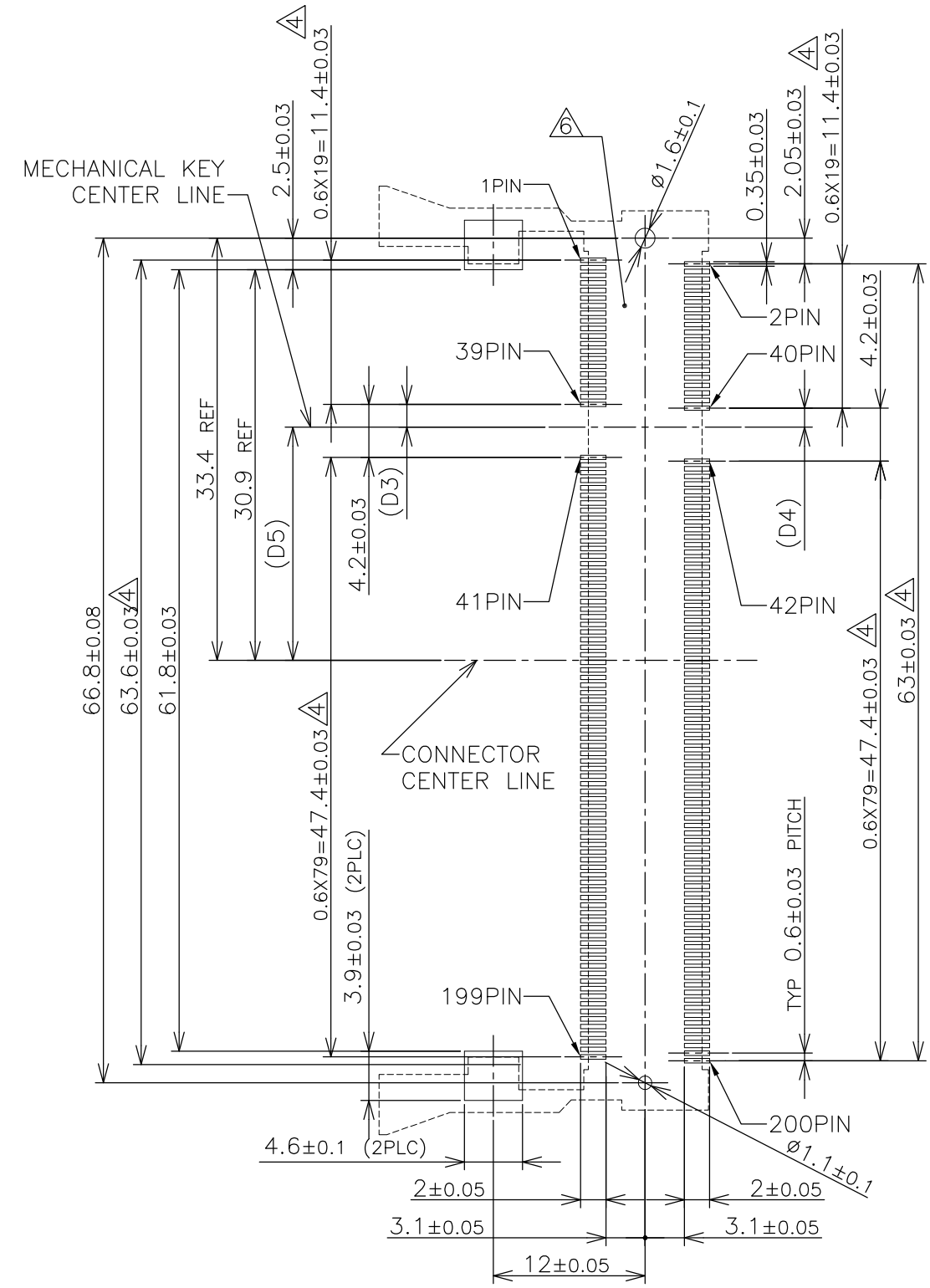

1.8V	17.55	2.4	2.7
2.5V	18.45	1.5	1.8
POWER SUPPLY	D5	D4	D3

THIS DRAWING IS A CONTROLLED DOCUMENT.		DWN	STE TE Connectivity	
DIMENSIONS: mm		CHK		
TOLERANCES UNLESS OTHERWISE SPECIFIED:		APVD	NAME	
0 PLC ±		PRODUCT SPEC	DDR1 & DDR2 SODIMM SOCKET	
1 PLC ±		APPLICATION SPEC	0.6mm PITCH 200POS	
2 PLC ±		WEIGHT	6.5 HEIGHT REVERSE TYPE	
3 PLC ±		CUSTOMER DRAWING	SIZE	CAGE CODE
4 PLC ±			A3	00779
ANGLES ±		DRAWING NO	RESTRICTED TO	
FINISH		G-1612773		
		SCALE	SHEET	REV
		2:1	2 OF 4	G2

THIS DRAWING IS UNPUBLISHED. RELEASED FOR PUBLICATION JUL ,2002.
 © COPYRIGHT 2002 By - ALL RIGHTS RESERVED.

LOC	DIST	REVISIONS			
P	LTR	DESCRIPTION	DATE	DWN	APVD
J		SEE SHEET 1	-	-	-

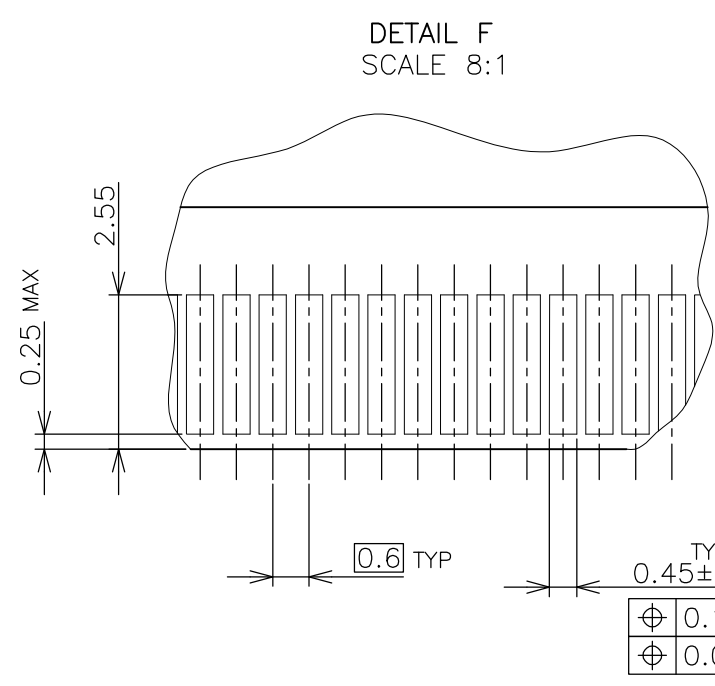
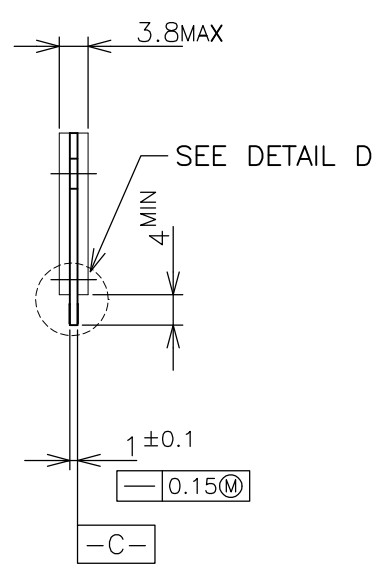
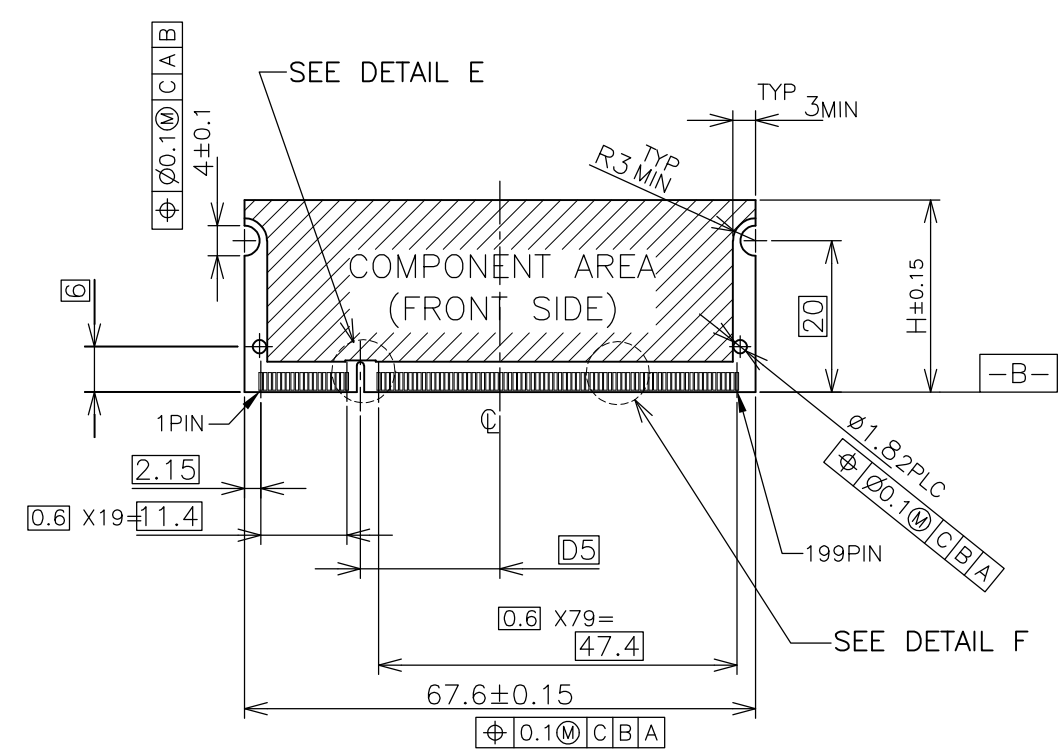

- (APPLIED TO SHEET 3)
1. TOLERANCES ON ALL DIMENSIONS ±0.15 UNLESS OTHERWISE SPECIFIED.
 2. P.C.BOARD THICKNESS APPLIES ACROSS TABS AND INCLUDES PLATING AND/OR METALIZATION.
 3. FINISH OF PAD : GOLD PLATING 0.00076 MIN. OVER Ni PLATING 0.002MIN.
- △ NO BURR
 △ CHAMFER 0.25 MAX x 45° IF EXIST.

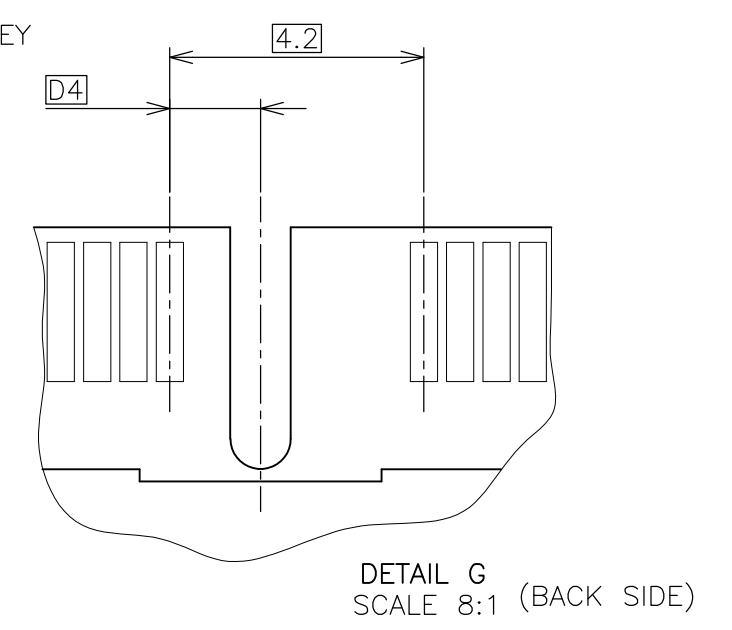
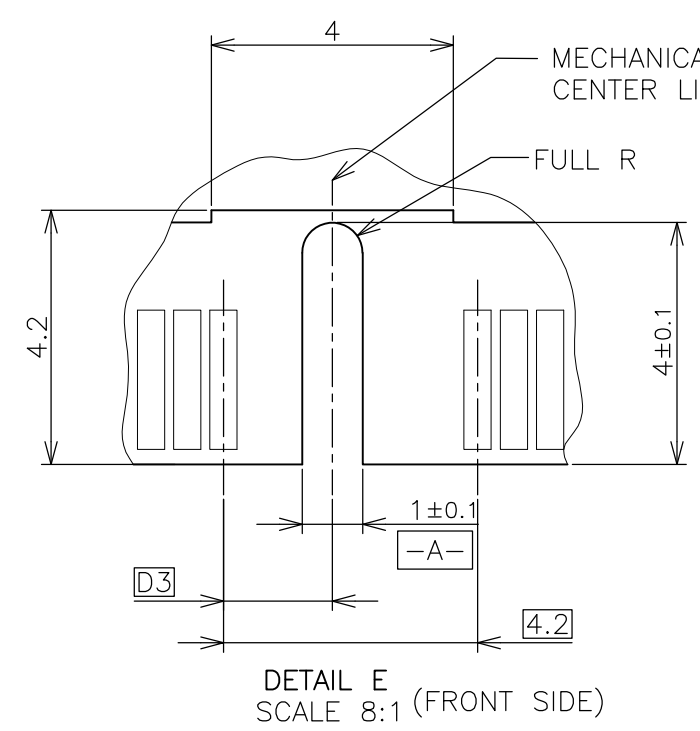
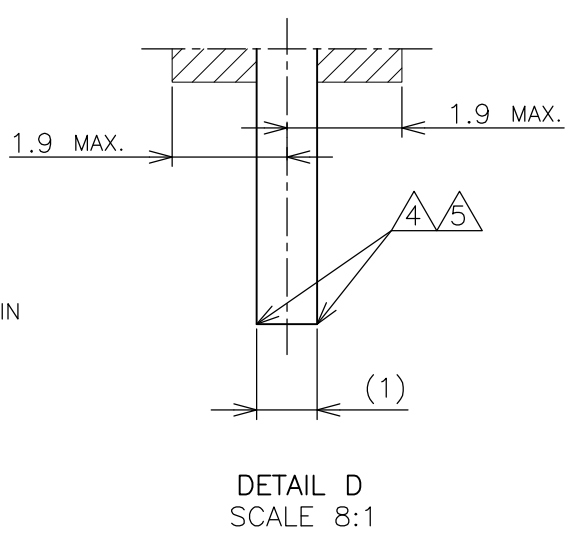
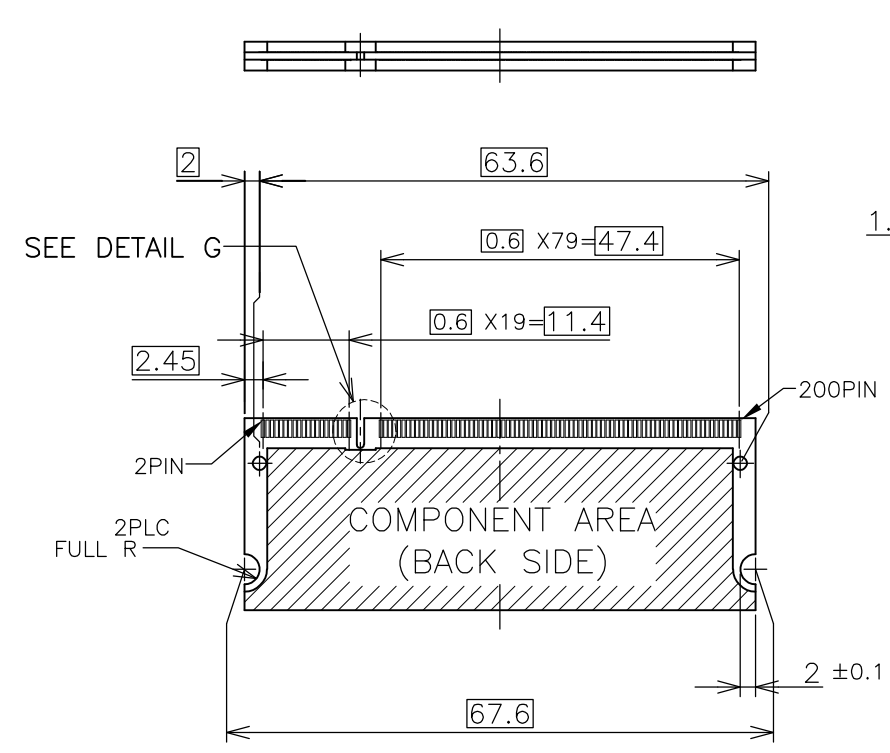

推奨基板仕様
 RECOMMENDED MATING P.C.B CONFIGURATION

THIS DRAWING IS A CONTROLLED DOCUMENT.		DWN
DIMENSIONS: mm		CHK
TOLERANCES UNLESS OTHERWISE SPECIFIED:		APVD
0 PLC	±	PRODUCT SPEC
1 PLC	±	APPLICATION SPEC
2 PLC	±	WEIGHT
3 PLC	±	
4 PLC	±	
ANGLES	±	
FINISH		
MATERIAL		

31.75	1.8V	17.55	2.4	2.7
25.4	2.5V	18.45	1.5	1.8
H	POWER SUPPLY	D5	D4	D3

STE TE Connectivity

NAME: DDR1 & DDR2 SODIMM SOCKET
 0.6mm PITCH 200POS
 6.5 HEIGHT REVERSE TYPE

SIZE: A3 CAGE CODE: 00779 DRAWING NO: C-1612773 RESTRICTED TO: G2

CUSTOMER DRAWING SCALE: 1:1 SHEET: 3 OF 4 REV: G2

THIS DRAWING IS UNPUBLISHED. RELEASED FOR PUBLICATION JUL ,2002.
 © COPYRIGHT 2002 By - ALL RIGHTS RESERVED.

LOC	DIST	REVISIONS			
P	LTR	DESCRIPTION	DATE	DWN	APVD
J		SEE SHEET 1	-	-	-

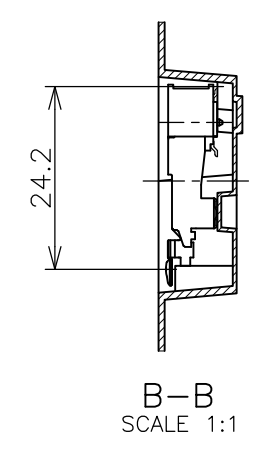
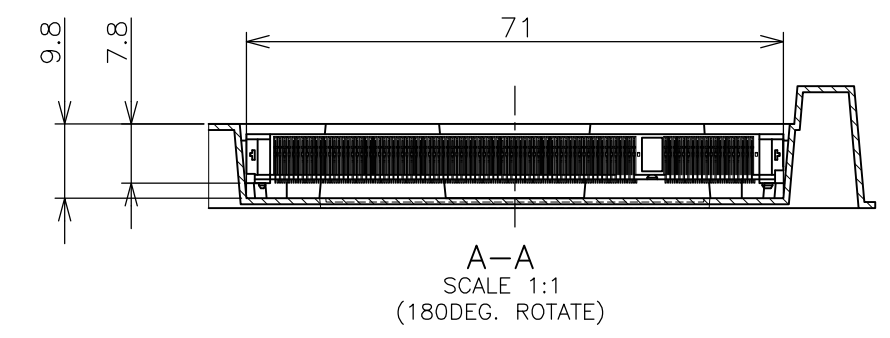
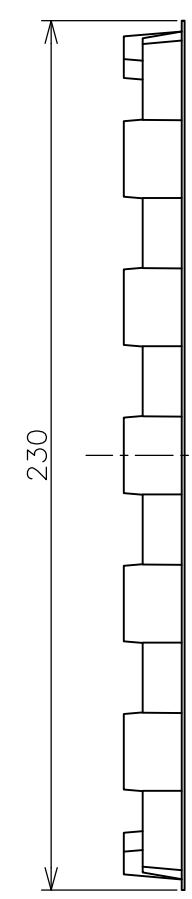
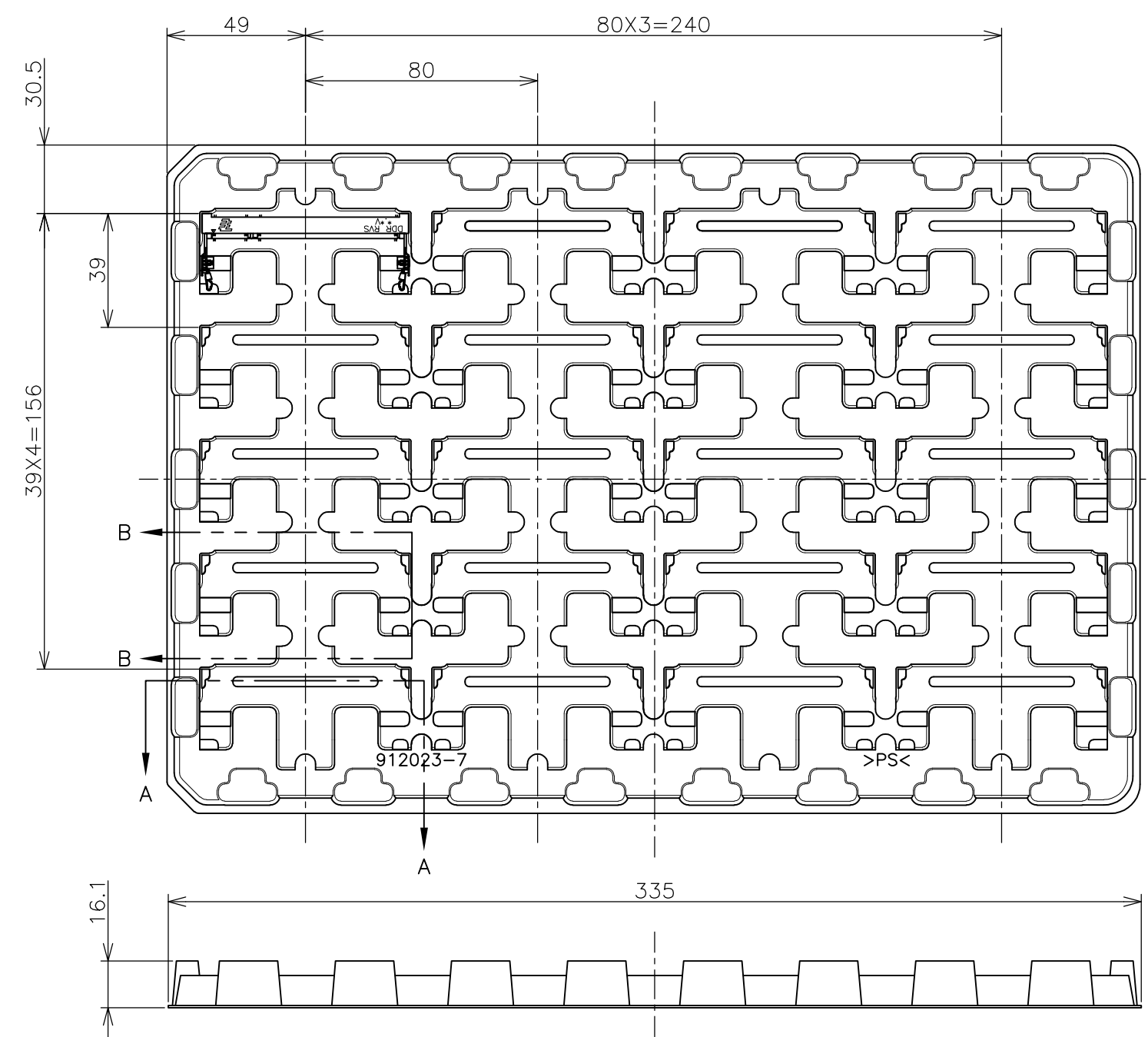

1. THE DIRECTION OF EACH CONNECTOR ON A TRAY IS REFERRED TO THIS DRAWING.
2. GENERAL TOLERANCE: ±0.5

20EA/TRAY	5-1612773-4
20EA/TRAY	1-1612773-4
20EA/TRAY	1612773-4
20EA/TRAY	5-1612773-1
20EA/TRAY	1612773-1
QTY	P/N

THIS DRAWING IS A CONTROLLED DOCUMENT.		DWN	TE Connectivity NAME DDR1 & DDR2 SODIMM SOCKET 0.6mm PITCH 200POS 6.5 HEIGHT REVERSE TYPE			
DIMENSIONS: mm		CHK				
TOLERANCES UNLESS OTHERWISE SPECIFIED:		APVD				
0 PLC ± 1 PLC ± 2 PLC ± 3 PLC ± 4 PLC ± ANGLES ± FINISH ±		PRODUCT SPEC				
MATERIAL		APPLICATION SPEC	SIZE	CAGE CODE	DRAWING NO	RESTRICTED TO
		WEIGHT	A3	00779	C-1612773	
CUSTOMER DRAWING			SCALE	SHEET	REV	
			1:2	4 OF 4	G2	

Looking for pricing, stock, or lifecycle information?

Click below to explore more details on WIN SOURCE:

 [View 5-1612773-1 on WIN SOURCE](#)

 [TE Connectivity](#) Information

Optimize Your Supply Chain with WIN SOURCE Solutions

-  Global Sourcing Solution
-  Obsolete Management
-  Cost Control Management
-  Shortage Management
-  Alternative Solution
-  Excess Inventory Management