



**THE DATASHEET OF**  
**2746595**



## **AUTOMATIONWORX**

### **User Manual**

**UM EN IBS SRE 1A**

**Order No.: 2888741**

INTERBUS Register Expansion Chip  
IBS SRE 1A

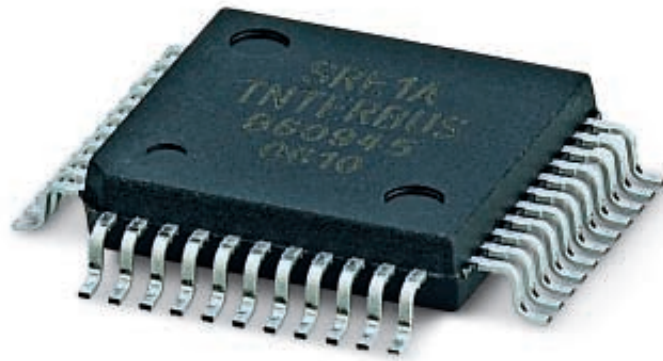



# AUTOMATIONWORX

## User Manual

### INTERBUS Register Expansion Chip IBS SRE 1A

06/2006

---

Designation: UM EN IBS SRE 1A

Revision: 01

Order No.: 2888741

This user manual is valid for:

Designation  
IBS SRE 1A

Order No.  
2746595

## Please Observe the Following Notes

In order to ensure the safe use of the product described, we recommend that you read this manual carefully. The following notes provide information on how to use this manual.

### User Group of This Manual

The use of products described in this manual is oriented exclusively to qualified electricians or persons instructed by them, who are familiar with applicable standards and other regulations regarding electrical engineering and, in particular, the relevant safety concepts.

Phoenix Contact accepts no liability for erroneous handling or damage to products from Phoenix Contact or third-party products resulting from disregard of information contained in this manual.

### Explanation of Symbols Used



The *attention* symbol refers to an operating procedure which, if not carefully followed, could result in damage to hardware and software or personal injury.



The *note* symbol informs you of conditions that must strictly be observed to achieve error-free operation. It also gives you tips and advice on the efficient use of hardware and on software optimization to save you extra work.



The *text* symbol refers to detailed sources of information (manuals, data sheets, literature, etc.) on the subject matter, product, etc. This text also provides helpful information for the orientation in the manual.

### We Are Interested in Your Opinion

We are constantly striving to improve the quality of our manuals.

Should you have any suggestions or recommendations for improvement of the contents and layout of our manuals, please send us your comments.

PHOENIX CONTACT GmbH & Co. KG  
Documentation Services  
32823 Blomberg  
Germany

Phone +49 - 52 35 - 30 0  
Fax +49 - 52 35 - 34 20 21  
E-mail [tecdoc@phoenixcontact.com](mailto:tecdoc@phoenixcontact.com)

### **General Terms and Conditions of Use for Technical Documentation**

Phoenix Contact GmbH & Co. KG reserves the right to alter, correct, and/or improve the technical documentation and the products described in the technical documentation at its own discretion and without giving any notice.

The provision of technical documentation (in particular data sheets, installation instructions, manuals, etc.) does not constitute any further duty on the part of Phoenix Contact GmbH & Co. KG to furnish information on alterations to products and/or technical documentation. Any other agreement shall only apply if expressly confirmed in writing by Phoenix Contact GmbH & Co. KG. Please note that the supplied documentation is product-specific documentation only.

Although Phoenix Contact GmbH & Co. KG makes every effort to ensure that the information content is accurate, up-to-date, and state-of-the-art, technical inaccuracies and/or printing errors in the information cannot be ruled out.

Phoenix Contact GmbH & Co. KG does not offer any guarantees as to the reliability, accuracy or completeness of the information provided. Phoenix Contact GmbH & Co. KG accepts no liability or responsibility for errors or omissions in the content of the technical documentation (in particular data sheets, installation instructions, manuals, etc.).

As far as is permissible by applicable jurisdiction, no guarantee or claim for liability for defects whatsoever shall be granted in conjunction with the information available in the technical documentation, whether expressly mentioned or implied. This information does not include any guarantees on quality, does not describe any fair marketable quality and does not make any claims as to quality guarantees or guarantees on the suitability for a special purpose.

Phoenix Contact GmbH & Co. KG reserves the right to alter, correct, and/or improve the information and the products described in the information at its own discretion and without giving any notice.

### **Statement of Legal Authority**

This manual, including all illustrations contained herein, is copyright protected. Use of this manual by any third party is forbidden. Reproduction, translation, or electronic and photographic archiving or alteration requires the express written consent of Phoenix Contact. Violators are liable for damages.

Phoenix Contact reserves the right to make any technical changes that serve the purpose of technical progress.

Phoenix Contact reserves all rights in the case of patent award or listing of a registered design. Third-party products are always named without reference to patent rights. The existence of such rights shall not be excluded.

### **Internet**

Up-to-date information on Phoenix Contact products can be found on the Internet at:

[www.phoenixcontact.com](http://www.phoenixcontact.com)

Make sure you always use the latest documentation.

It can be downloaded at:

[www.download.phoenixcontact.com](http://www.download.phoenixcontact.com)

A conversion table is available on the Internet at:

[www.download.phoenixcontact.com/general/7000\\_en\\_00.pdf](http://www.download.phoenixcontact.com/general/7000_en_00.pdf)

# Table of Contents

1	Introduction .....	1
1.1	Serial Register Expansion Chip .....	1
1.2	Area of Application .....	1
1.3	Housing Type .....	2
1.3.1	Pin Assignment .....	2
1.3.2	Pin Table .....	3
1.3.3	Dimensions .....	4
1.3.4	Signal Description .....	5
2	Basic Wiring .....	6
2.1	Clock Supply and Initialization .....	6
2.1.1	Clock Supply .....	6
2.1.2	Initialization .....	6
2.2	Connection to the Protocol Chips.....	7
2.2.1	Serial Interface Timing .....	8
2.3	Setting the Data Length .....	10
3	Microprocessor Access .....	11
3.1	Timing for the Microprocessor Interface .....	12
3.2	Address Area Assignment.....	13
3.2.1	INTERBUS Data Registers .....	14
3.2.2	Configuration Register .....	14
3.3	Interrupt Operation .....	16
4	Technical Data and Ordering Data .....	17
4.1	Technical Data .....	17
4.2	Ordering Data.....	17



# 1 Introduction

This manual describes the IBS SRE 1A register expansion chip for the INTERBUS SUP-I protocol chip family. It can be used to easily expand the data length of the protocol chips if the internal data registers are insufficient. The maximum of six additional data words can be accessed via a microprocessor.

This manual and the manuals for INTERBUS SUP-I protocol chips can be used to implement custom INTERBUS devices, which should be subjected to a conformance test.

INTERBUS is a serial sensor/actuator bus. It comprises a central intelligent controller board (controller or IB master) in a host system and distributed I/O modules.

IBS SUP-I protocol chips are used for integrating I/O modules in an INTERBUS network. In this document, "IBS SUP-I" refers to all INTERBUS protocol chips in the SUP-I range.

On the I/O side, the IBS SUP-I has a multi-function interface (MFP **M**ulti-**F**unction **P**ins). Depending on the function of the INTERBUS device, the MFP interface can be configured as a direct I/O interface or as a processor interface.



## Electrostatic discharge

The chip can be damaged or destroyed by electrostatic discharge. When handling the chip, observe the necessary safety precautions against electrostatic discharge (ESD) according to EN 61340-5-1 and EN 61340-5-2.

## 1.1 Serial Register Expansion Chip

The **S**erial **R**egister **E**xpansion chip (SRE) is an ASIC in 0.8- $\mu$ m gate array technology with approximately 4000 gate equivalents. It has one serial input and one serial output as well as a microprocessor interface for accessing the internal INTERBUS data registers. The IBS SRE 1A was specially developed as a register expansion for IBS SUP-I INTERBUS protocol chips. However, it can also be used in other applications.

For the ordering data, please refer to "Technical Data and Ordering Data" on page 1-17.

## 1.2 Area of Application

The IBS SRE 1A is suitable for use in industrial applications.

Table 1-1 Area of application

Value	Amount		
	Minimum	Typical	Maximum
Supply voltage	4.5 V	5.0 V	5.5 V
Temperature	-40°C	+25°C	+85°C

### 1.3 Housing Type

The IBS SRE 1A is housed in a QFP44 housing.

#### 1.3.1 Pin Assignment

(Quad Flat Pack)

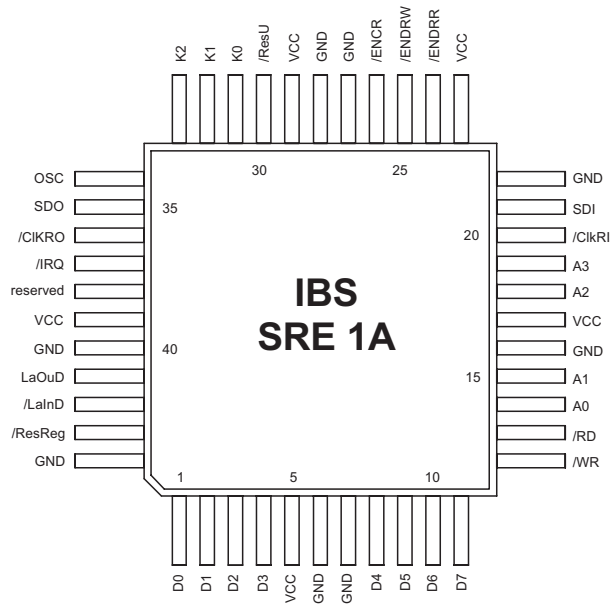

7295A001

Figure 1-1 QFP44 housing with pin assignment

### 1.3.2 Pin Table

Table 1-2 QFP44 pin table

Pin No.	Pin Name	Pin No.	Pin Name
1	D0	23	V <sub>CC</sub>
2	D1	24	/ENDRR
3	D2	25	/ENDRW
4	D3	26	/ENCR
5	V <sub>CC</sub>	27	GND
6	GND	28	GND
7	GND	29	V <sub>CC</sub>
8	D4	30	/ResU
9	D5	31	K0
10	D6	32	K1
11	D7	33	K2
12	/WR	34	OSC
13	/RD	35	SDO
14	A0	36	/ClkRO
15	A1	37	/IRQ
16	GND	38	Test
17	V <sub>CC</sub>	39	V <sub>CC</sub>
18	A2	40	GND
19	A3	41	LaOuD
20	/ClkRI	42	/LaInD
21	SDI	43	/ResReg
22	GND	44	GND

### 1.3.3 Dimensions

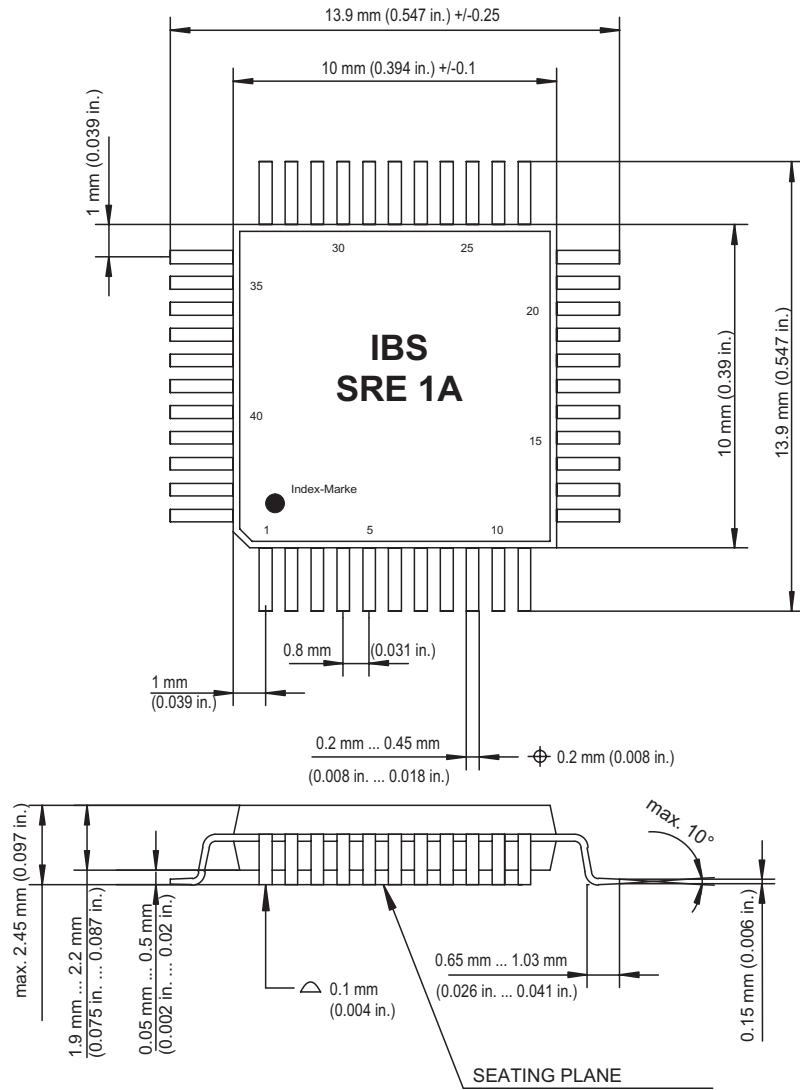

7295A002

Figure 1-2 QFP44 housing with dimensions

### 1.3.4 Signal Description

Table 1-3 Signal description for the IBS SRE 1A

Designation	Meaning	Type
OSC	Oscillator input	ST
K0 K1 K2	Configuration inputs for the internal registers	ST
D0 - D7	Data bus for the microprocessor interface	BD
A0 - A3	Address bus for the microprocessor interface	CI
/RD /WR /IRQ	/Read /Write /Interrupt Request  Control bus for the microprocessor interface	CI CI B2
/ENCR	Enable signal for the configuration register <sup>1</sup>	CI
/ENDRR	/READ enable signal for the data registers <sup>1</sup>	CI
/ENDRW	/WRITE enable signal for the data registers <sup>1</sup>	CI
SDI	Data input for the IBS SRE 1A (should be connected to data output <i>ToExR1</i> or <i>ToExR2</i> of the IBS SUPI)	ST
SDO	Data output for the IBS SRE 1A (should be connected to data input <i>FromExR</i> of the IBS SUPI)	B2
/ClkRI	Clock input for the internal shift registers for SRE 1A	CI
/ClkRO	Clock output for the internal shift registers for other IBS SRE 1A chips or conventional shift registers	B2
LaOuD	Transmission signal for output data for the IBS SRE 1A INTERBUS → OUT memory area	ST
/LaInD	Transmission signal for input data for the IBS SRE 1A IN memory area → INTERBUS	ST
/ResReg	Reset signal for the internal data registers of the IBS SRE 1A	ST
/ResU	Initialization reset	ST <sub>pu</sub>
Test	Leave open; test pin for in-circuit test by the ASIC manufacturer	B2
V <sub>CC</sub>	Supply voltage +5 V	
GND	Ground	

<sup>1</sup> In normal microprocessor mode, these signals should be grouped as the chip select for the IBS SRE 1A.

**Cell types:**

- BD: Bidirectional, with Schmitt trigger inputs and 2 mA driver outputs
- CI: CMOS input
- ST: CMOS Schmitt trigger input
- ST<sub>pu</sub>: CMOS Schmitt trigger input with internal pull-up
- B2: 2 mA driver output

Electrical data: See section 4 on page 17

## 2 Basic Wiring

### 2.1 Clock Supply and Initialization

#### 2.1.1 Clock Supply

The IBS SRE 1A has a Schmitt trigger input. The required clock can be either that of the connected microprocessor or that of the IBS SUPI. However, if the IBS SUPI clock is used, the IBS SUPI must be clocked using an oscillator.



The quartz circuit of the IBS SUPI must not be modified.

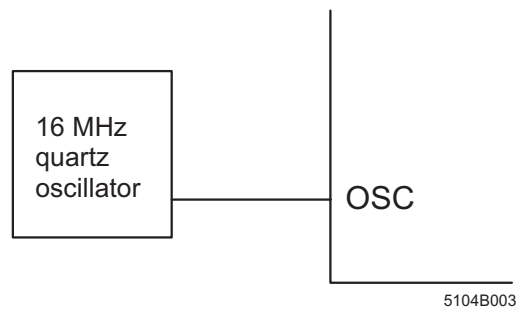

Figure 2-1 Clock supply for the IBS SRE 1A

#### 2.1.2 Initialization

In order to place the IBS SRE 1A in a defined state after power up, the initialization input /ResU should be set to "Low" during the power up phase. During operation, /ResU should be set to "High". The simplest option is to connect the /ResU input of the IBS SRE 1A with the /ResU input of the IBS SUPI.



The power up phase must be at least 125 ns.

## 2.2 Connection to the Protocol Chips

In addition to the serial data inputs and outputs, the IBS SRE 1A has a microprocessor interface for parallel access to internal INTERBUS data registers. Connection to the IBS SUPI is via the serial data inputs and outputs and the associated control signals (Latch, Clock, Reset). Since the IBS SRE 1A was developed as an expansion chip for the IBS SUPI, the inputs and outputs for data and control signals can be connected together directly.

The IBS SRE 1A is connected to the IBS SUPI according to the specifications for the connection of a register expansion in the IBS SUPI user manual. The serial data input SDI of the IBS SRE 1A is connected to the shift register data output *ToExR1* or *ToExR2* of the IBS SUPI. The serial data output SDO of the IBS SRE 1A should be connected to pin *FromExR* of the IBS SUPI. This closes the data ring.

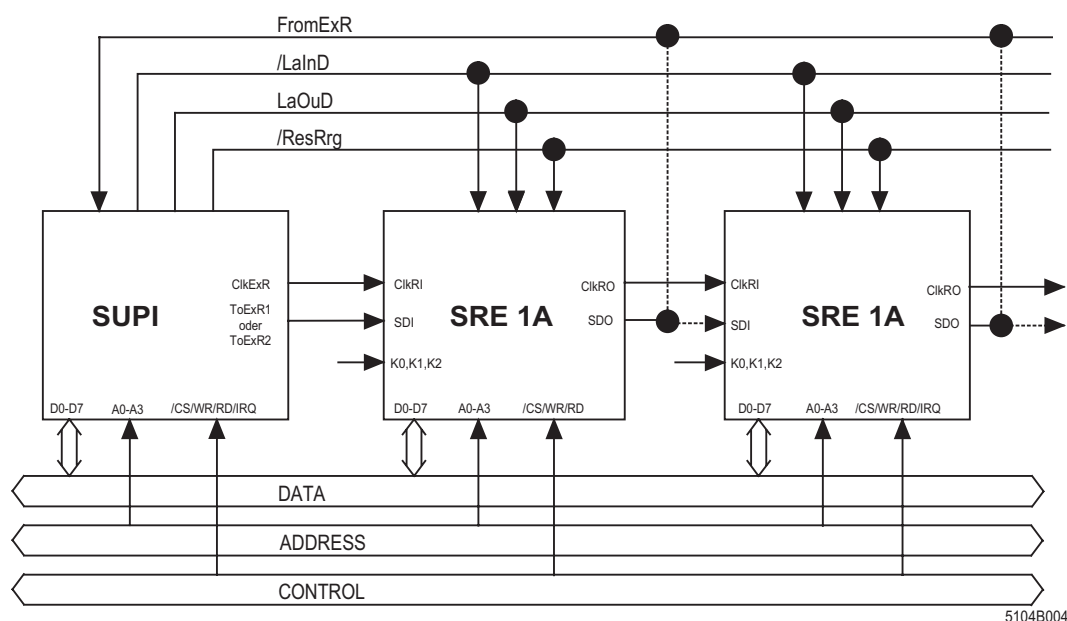

5104B004

Figure 2-2 Connection to the IBS SUPI

It is also possible to connect up to six expansion chips in succession or to use other conventional shift registers. The signals *LaOuD*, */LaInD*, and */ResReg* should be assigned in parallel to all IBS SRE 1A chips. The */ClkExR* clock output of the SUPI should be connected to the *ClkRI* clock input of the IBS SRE 1A. For the clock supply of other IBS SRE 1A chips or conventional shift registers, the */ClkRO* clock output of the IBS SRE 1A should be used.

### 2.2.1 Serial Interface Timing

The timing for the serial interface matches the timing for the IBS SUPI register expansion. The timing for the serial interface of the IBS SRE 1A can be found in the diagrams below.

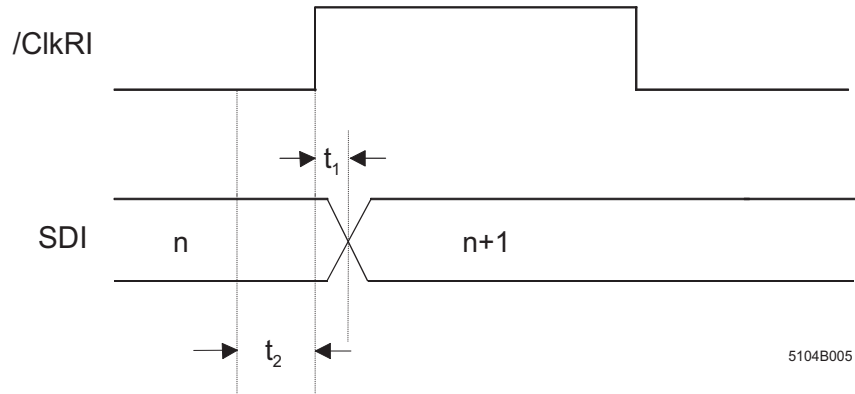
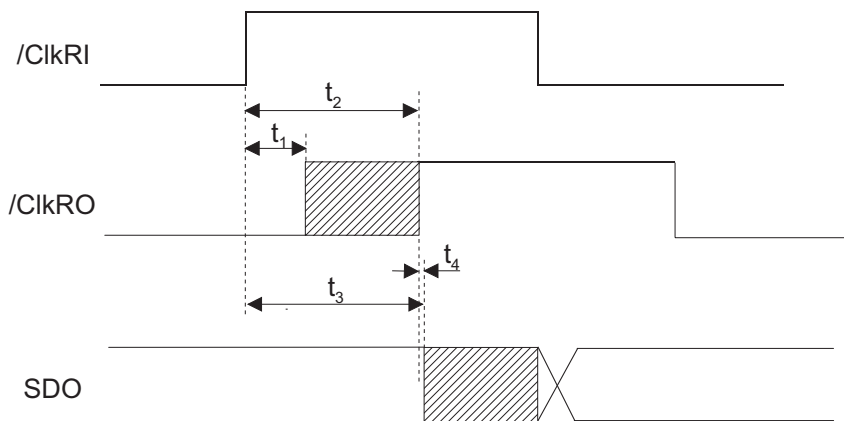

Figure 2-3 Timing for the serial IN interface of the IBS SRE 1A

Symbol	Explanation	Time
$t_1$	SDI valid after the rising edge of /ClkRI min.	1.1 ns
$t_2$	SDI valid before the rising edge of /ClkRI min.	12 ns



5104B006

Figure 2-4 Timing for the serial OUT interface of the IBS SRE 1A

Symbol	Explanation	Time
t <sub>1</sub>	Minimum delay /ClkRI after /ClkRO	9.9 ns
t <sub>2</sub>	Maximum delay /ClkRI after /ClkRO	15.5 ns
t <sub>3</sub>	SDO valid after the rising edge of /ClkRI min.	16.6 ns
t <sub>4</sub>	SDO valid after the rising edge of /ClkRO min.	1.1 ns

## 2.3 Setting the Data Length

The data length of the serial register expansion chip can be set to 0 to 6 words. The data length of the IBS SRE 1A can be configured via hardware and via software.

For configuration via hardware, the data length is set by wiring the three pins K0, K1, and K2.

These pins can be used to make the following settings:

Table 2-1 Configuration of the data length

K2	K1	K0	Data Width
0	0	0	0 words
0	0	1	1 word
0	1	0	2 words
0	1	1	3 words
1	0	0	4 words
1	0	1	5 words
1	1	0	6 words

As an option, the data width can be set by writing to the CONF register of the IBS SRE 1A (addressing, see section 3.2.2 on page 14).

### 3 Microprocessor Access

The IBS SRE 1A is addressed by a microprocessor such as an I/O component (e.g., RAM). The IBS SRE 1A has an 8-bit bidirectional data bus (D0 to D7), a 4-bit address bus (A0 to A3), active-low control signals Chip Select /CS (/ENCR, /ENDRR, /ENDRW), Read (/RD), and Write (/WR) and an active-low interrupt request line (/IRQ). The separate enable signals can be used to specifically enable individual data areas of the IBS SRE 1A.

The meaning of the signals can be found in the following table.

Table 3-1 Meaning of chip select signals

Enable Signal	Meaning
/ENCR	Enable signal for the configuration register
/ENDRR	Enable signal for read access to the data registers
/ENDRW	Enable signal for write access to the data registers

In normal microprocessor mode, these signals should be grouped as the chip select for the IBS SRE 1A.

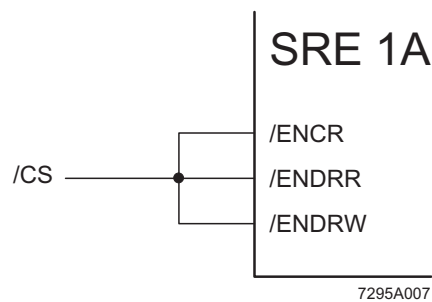
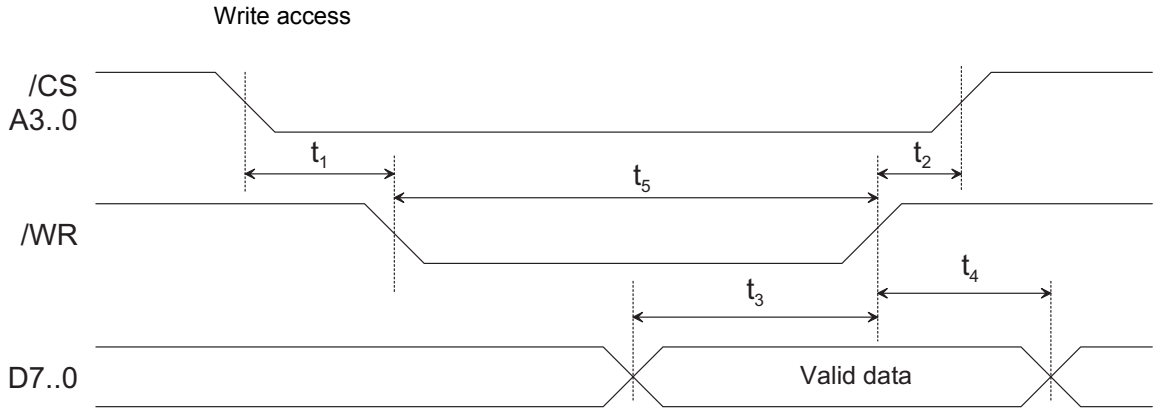

Figure 3-1 Chip select signal for the IBS SRE 1A



The timing in Figure 3-2 must be observed exactly. In the event of access problems when using a Motorola processor (e.g., problems with configuration register access), the problems can be solved by connecting pin /ENCR to GND.

### 3.1 Timing for the Microprocessor Interface



5104B010

Figure 3-2 Timing for write access

Table 3-2 Timing for the microprocessor interface - write access

Symbol	Explanation	Minimum Time
$t_1$	Addresses and /CS valid before negative edge of /WR	5 ns
$t_2$	Addresses and /CS valid after positive edge of /WR	5 ns
$t_3$	Valid data before positive edge of /WR	15 ns
$t_4$	Valid data after positive edge of /WR	10 ns
$t_5$	/WR pulse width	30 ns

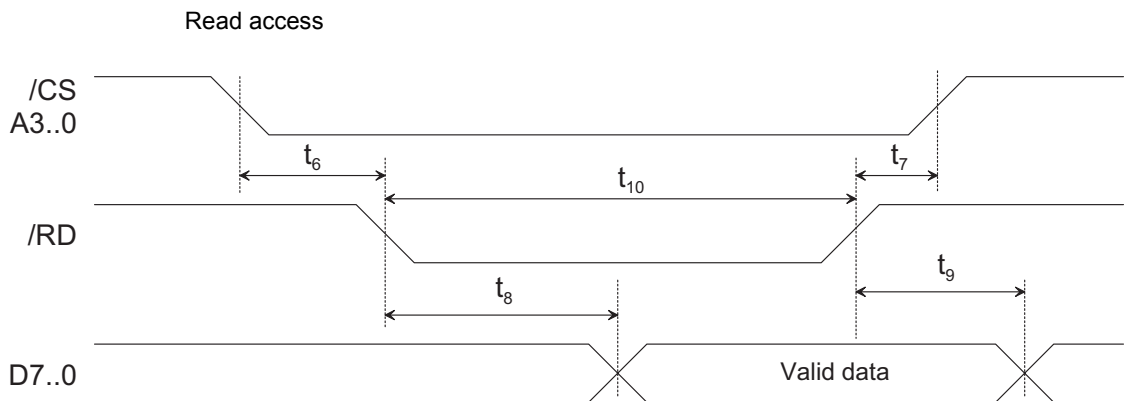

5104B011

Figure 3-3 Timing for read access

Table 3-3 Timing for the microprocessor interface - read access

Symbol	Explanation	Time	
		Minimum	Maximum
t <sub>6</sub>	Addresses and /CS stable before negative edge of /RD	10 ns	
t <sub>7</sub>	Addresses and /CS stable after positive edge of /RD	10 ns	
t <sub>8</sub>	Valid data after negative edge of /RD		25 ns
t <sub>9</sub>	Data bus high resistance after positive edge of /RD		26 ns
t <sub>10</sub>	/RD pulse width	30 ns	

### 3.2 Address Area Assignment

Four address lines (A0 - A3) are available for the IBS SRE 1A. The address area that can be accessed via the microprocessor interface has the following structure:

Table 3-4 Address area assignment for the IBS SRE 1A

Relative Address	Write Register	Read Register
0	IBS IN byte 0	IBS OUT byte 0
1	IBS IN byte 1	IBS OUT byte 1
2	IBS IN byte 2	IBS OUT byte 2
3	IBS IN byte 3	IBS OUT byte 3
4	IBS IN byte 4	IBS OUT byte 4
5	IBS IN byte 5	IBS OUT byte 5
6	IBS IN byte 6	IBS OUT byte 6
7	IBS IN byte 7	IBS OUT byte 7
8	IBS IN byte 8	IBS OUT byte 8
9	IBS IN byte 9	IBS OUT byte 9
10	IBS IN byte 10	IBS OUT byte 10
11	IBS IN byte 11	IBS OUT byte 11
12	CONFREG	CLEAR IRQ
13	Unused	Unused
14	Unused	Unused
15	Unused	Unused

All registers of the IBS SRE 1A have the default value "0".

The INTERBUS data registers are set to their default value via the initialization input /ResU and by an INTERBUS reset. However, the CONFREG configuration register can only be reset via the initialization input (/ResU).

### 3.2.1 INTERBUS Data Registers

The INTERBUS data registers with addresses 0 to 11 are designed for the exchange of I/O data between a slave application and the INTERBUS master. The "IB IN byte" data registers should be written by the slave application. This data is IN data for the INTERBUS master, whereas the "IB OUT byte" data registers should be read by the slave application. This data is OUT data for the INTERBUS master.

The value of the data registers falls as the address rises, i.e., for a device with a data width of 8 bytes, the byte with address 0 is the high byte and the byte with address 7 is the low byte.

The value of the data in the memory areas of the IBS SUPI and any other register expansion chips is shown below:

High byte	High byte of the IBS SUPI
.	Memory area of the IBS SUPI
.	Low byte of the IBS SUPI
.	High byte of the first IBS SRE 1A
.	Memory area of the first register expansion chip
.	Low byte of the first IBS SRE 1A
.	High byte of the second IBS SRE 1A
.	Memory area of the second register expansion chip
.	Low byte of the second IBS SRE 1A
.	.
.	.
.	.
.	.
.	High byte of the last IBS SRE 1A
.	Memory area of the last register expansion chip
Low byte	Low byte of the last IBS SRE 1A

### 3.2.2 Configuration Register

The "CONFREG" configuration register at relative address 12 can be used to set the data length of the IBS SRE 1A via the software. However, it must be noted that the correct data length of the entire device is stored in the identification register of the IBS SUPI (ID8 to 12).

In addition, an interrupt for alternative synchronization with a microprocessor can be enabled in the configuration register. However, it is preferable that the interrupt of the IBS SUPI is used for synchronization with the application.

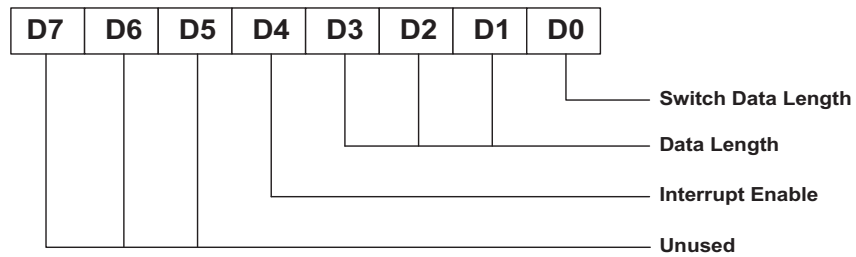

5104B008

Figure 3-4 Structure of the configuration register

**Switch Data Length**

0 external, 1 internal

This bit is used to separate the hardware connections of the pins and redirect them to bits D3 to D1.

Table 3-5 Internal or external configuration of the data length

D0	Data Length Setting
0	K0 to K2 (physical pins)
1	D1 to D3 (bits in the configuration register)

**Data Length**

These bits are used to set the data length.

Table 3-6 Setting the data length via the register

D3	D2	D1	Data Length
0	0	0	0 words
0	0	1	1 word
0	1	0	2 words
0	1	1	3 words
1	0	0	4 words
1	0	1	5 words
1	1	0	6 words

**Interrupt Enable**

This bit is used to enable the interrupt request of the IBS SRE 1A.

Table 3-7 Enable bit for the interrupt

D4	Interrupt Request
0	Disabled
1	Enabled

### 3.3 Interrupt Operation

Since the connected microprocessor typically reads and writes the INTERBUS data registers asynchronously to the INTERBUS cycle, inconsistent data may be transmitted if the read and write process falls in the latch phase of an INTERBUS cycle.

The latch phase completes the check sequence of every INTERBUS cycle. In this phase, the stored OUT data is saved to the IB OUT data registers and the data in the IB IN data registers is transferred to INTERBUS.

In order to prevent the transmission of inconsistent data, the IBS SUP1 has an interrupt logic for synchronization, which provides a range of INTERBUS cycle-synchronous events as interrupt sources (see also IBS SUP1 user manual).

In addition, it is possible to request certain events using polling bits (see also IBS SUP1 user manual).

If the IBS SUP1 **cannot** be used for synchronization, an interrupt request signal is available for synchronizing CPU access to the INTERBUS data registers of the IBS SRE 1A.

The interrupt is enabled by writing a "1" in bit D4 in the CONF register with relative address 12 (only once during initialization).

/IRQ is activated on every rising edge of the /LaInD transmission signal. After every interrupt request (/IRQ goes to low), a read access to relative address 12 is required. The contents of this register are not relevant. Once relative address 12 has been read, the /IRQ line goes to inactive (high). Data can now be read from the IB OUT data registers, and the IB IN data registers can be written by the CPU.

After an interrupt request (/IRQ low), the CPU is available for reading the IB OUT data registers and the relative address 12 as well as for writing the IB IN data registers for the following minimum time:

$$t = [(6 + n) \times 13 \times t_{\text{Bit}}] - 26.67 \mu\text{s}$$

Where

$t_{\text{Bit}}$ : Length of an INTERBUS bit (typical: 2  $\mu\text{s}$ )  
 $n$ : Number of data bytes in the entire network  
 $t$ : Permissible access time for the CPU

Please note that the minimum time  $t$  applies if the INTERBUS network comprises only the user's device.

#### Example:

Implemented device: 4 bytes (32 bits). The IN and OUT direction should be used.

The worst-case time is therefore:

$$\rightarrow t = 233 \mu\text{s}$$

The CPU has a maximum of 233  $\mu\text{s}$  after an interrupt request to read the CLEAR IRQ register and the IB OUT data registers and to write the IB IN data registers.

## 4 Technical Data and Ordering Data

### 4.1 Technical Data

Electrical Data	
Power supply $V_{CC}$	4.5 V ... 5.5 V DC
Input voltages	-0.3 V ... $V_{CC} + 0.3$ V
Current consumption <sup>1</sup>	≈ 10 mA
Temperature range	-40°C ... +85°C (industrial)
CMOS input voltage	
High	3.5 V ... $V_{CC} + 0.3$ V
Low	-0.3 V ... +1.5 V
Schmitt trigger inputs	
Positive switching threshold	2.4 V ... 4.0 V
Negative switching threshold	1.0 V ... 2.4 V
Hysteresis	0.5 V
CMOS output voltage	
High	3.7 V <sub>min</sub>
Low	0.4 V <sub>max</sub>
CMOS output current	2 mA

<sup>1</sup> All inputs are static. All outputs are unwired. The oscillator is operating.

### 4.2 Ordering Data

#### Chip

Description	Type	Order No.	Pcs./Pck.
INTERBUS register expansion chip with QFP44 housing	IBS SRE 1A	2746595	96

#### Documentation

Description	Type	Order No.	Pcs./Pck.
User manual for the IBS SUPI 3 INTERBUS protocol chip	IBS SUPI 3 UM E	–	1
User manual for the IBS SUPI 3 OPC INTERBUS protocol chip	IBS SUPI 3 OPC UM E	–	1
User manual for the IBS SUPI 2 INTERBUS protocol chip	IBS SUPI 2 HB E	2758787	1





Make sure you always use the latest documentation.  
 It can be downloaded at [www.download.phoenixcontact.com](http://www.download.phoenixcontact.com).  
 A conversion table is available on the Internet at  
[www.download.phoenixcontact.com/general/7000\\_en\\_00.pdf](http://www.download.phoenixcontact.com/general/7000_en_00.pdf).





## Looking for pricing, stock, or lifecycle information?

Click below to explore more details on WIN SOURCE:

-  [View 2746595 on WIN SOURCE](#)
-  [Phoenix Contact Information](#)

## Optimize Your Supply Chain with WIN SOURCE Solutions

-  Global Sourcing Solution
-  Obsolete Management
-  Cost Control Management
-  Shortage Management
-  Alternative Solution
-  Excess Inventory Management