



**THE DATASHEET OF  
DS92LV010ATM/NOPB**



## DS92LV010A Bus LVDS 3.3/5.0V Single Transceiver

Check for Samples: [DS92LV010A](#)

### FEATURES

- Bus LVDS Signaling (BLVDS)
- Designed for Double Termination Applications
- Balanced Output Impedance
- Lite Bus Loading 5pF Typical
- Glitch Free Power Up/Down (Driver Disabled)
- 3.3V or 5.0V Operation
- $\pm 1V$  Common Mode Range
- $\pm 100mV$  Receiver Sensitivity
- High Signaling Rate Capability (Above 100 Mbps)
- Low Power CMOS Design
- Product Offered in 8 Lead SOIC Package
- Industrial Temperature Range Operation

### DESCRIPTION

The DS92LV010A is one in a series of transceivers designed specifically for the high speed, low power proprietary bus backplane interfaces. The device operates from a single 3.3V or 5.0V power supply and includes one differential line driver and one receiver. To minimize bus loading the driver outputs and receiver inputs are internally connected. The logic interface provides maximum flexibility as 4 separate lines are provided (DIN, DE,  $\overline{RE}$ , and ROUT). The device also features flow through which allows easy PCB routing for short stubs between the bus pins and the connector. The driver has 10 mA drive capability, allowing it to drive heavily loaded backplanes, with impedance as low as 27 Ohms.

The driver translates between TTL levels (single-ended) to Low Voltage Differential Signaling levels. This allows for high speed operation, while consuming minimal power with reduced EMI. In addition the differential signaling provides common mode noise rejection of  $\pm 1V$ .

The receiver threshold is  $\pm 100mV$  over a  $\pm 1V$  common mode range and translates the low voltage differential levels to standard (CMOS/TTL) levels.

### CONNECTION DIAGRAM

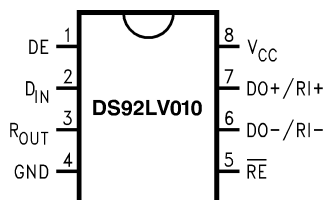

**Figure 1. SOIC Package**  
See Package Number D0008A

### BLOCK DIAGRAM

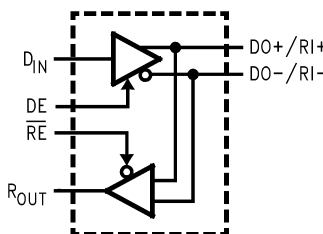

**Figure 2.**



Please be aware that an important notice concerning availability, standard warranty, and use in critical applications of Texas Instruments semiconductor products and disclaimers thereto appears at the end of this data sheet.

All trademarks are the property of their respective owners.



These devices have limited built-in ESD protection. The leads should be shorted together or the device placed in conductive foam during storage or handling to prevent electrostatic damage to the MOS gates.

### ABSOLUTE MAXIMUM RATINGS <sup>(1)(2)(3)</sup>

Supply Voltage ( $V_{CC}$ )		6.0V
Enable Input Voltage (DE, $\overline{RE}$ )		-0.3V to ( $V_{CC} + 0.3V$ )
Driver Input Voltage (DIN)		-0.3V to ( $V_{CC} + 0.3V$ )
Receiver Output Voltage ( $R_{OUT}$ )		-0.3V to ( $V_{CC} + 0.3V$ )
Bus Pin Voltage (DO/RI±)		-0.3V to + 3.9V
Driver Short Circuit Current		Continuous
ESD (HBM 1.5 k $\Omega$ , 100 pF)		>2.0 kV
Maximum Package Power Dissipation at 25°C	SOIC	1025 mW
	Derate SOIC Package	8.2 mW/°C
Junction Temperature		+150°C
Storage Temperature Range		-65°C to +150°C
Lead Temperature (Soldering, 4 sec.)		260°C

- (1) All currents into device pins are positive; all currents out of device pins are negative. All voltages are referenced to device ground except  $V_{OD}$ ,  $V_{ID}$ ,  $V_{TH}$  and  $V_{TL}$  unless otherwise specified.
- (2) Absolute Maximum Ratings are those beyond which the safety of the device cannot be ensured. They are not meant to imply that the device should be operated at these limits. The table of “[Electrical Characteristics](#)” provides conditions for actual device operation.
- (3) If Military/Aerospace specified devices are required, please contact the Texas Instruments Sales Office/ Distributors for availability and specifications.

### RECOMMENDED OPERATING CONDITIONS

	Min	Max	Units
Supply Voltage ( $V_{CC}$ ), or	3.0	3.6	V
Supply Voltage ( $V_{CC}$ )	4.5	5.5	V
Receiver Input Voltage	0.0	2.9	V
Operating Free Air Temperature	-40	+85	°C

### 3.3V DC ELECTRICAL CHARACTERISTICS <sup>(1)(2)</sup>

 $T_A = -40^{\circ}\text{C}$  to  $+85^{\circ}\text{C}$  unless otherwise noted,  $V_{CC} = 3.3\text{V} \pm 0.3\text{V}$ 

Parameter		Test Conditions		Pin	Min	Typ	Max	Units
$V_{OD}$	Output Differential Voltage	$R_L = 27\Omega$ , See <a href="#">Figure 3</a>		DO+/RI+, DO-/RI-	140	250	360	mV
$\Delta V_{OD}$	$V_{OD}$ Magnitude Change					3	30	mV
$V_{OS}$	Offset Voltage				1	1.25	1.65	V
$\Delta V_{OS}$	Offset Magnitude Change					5	50	mV
$I_{OSD}$	Output Short Circuit Current	$V_O = 0\text{V}$ , $DE = V_{CC}$				-12	-20	mA
$V_{OH}$	Voltage Output High	$V_{ID} = +100\text{mV}$	$I_{OH} = -400\mu\text{A}$	$R_{OUT}$	2.8	3		V
		Inputs Open			2.8	3		V
		Inputs Shorted			2.8	3		V
		Inputs Terminated, $R_L = 27\Omega$			2.8	3		V
$V_{OL}$	Voltage Output Low	$I_{OL} = 2.0\text{mA}$ , $V_{ID} = -100\text{mV}$				0.1	0.4	V
$I_{OS}$	Output Short Circuit Current	$V_{OUT} = 0\text{V}$ , $V_{ID} = +100\text{mV}$			-5	-35	-85	mA
$V_{TH}$	Input Threshold High	$DE = 0\text{V}$		DO+/RI+, DO-/RI-			+100	mV
$V_{TL}$	Input Threshold Low				-100			mV
$I_{IN}$	Input Current	$DE = 0\text{V}$ , $V_{IN} = +2.4\text{V}$ , or $0\text{V}$			-20	$\pm 1$	+20	$\mu\text{A}$
		$V_{CC} = 0\text{V}$ , $V_{IN} = +2.4\text{V}$ , or $0\text{V}$			-20	$\pm 1$	+20	$\mu\text{A}$
$V_{IH}$	Minimum Input High Voltage			DIN, DE, $\overline{RE}$	2.0		$V_{CC}$	V
$V_{IL}$	Maximum Input Low Voltage				GND		0.8	V
$I_{IH}$	Input High Current	$V_{IN} = V_{CC}$ or $2.4\text{V}$				$\pm 1$	$\pm 10$	$\mu\text{A}$
$I_{IL}$	Input Low Current	$V_{IN} = \text{GND}$ or $0.4\text{V}$				$\pm 1$	$\pm 10$	$\mu\text{A}$
$V_{CL}$	Input Diode Clamp Voltage	$I_{CLAMP} = -18\text{mA}$			-1.5	-0.8		V
$I_{CCD}$	Power Supply Current	$DE = \overline{RE} = V_{CC}$ , $R_L = 27\Omega$		$V_{CC}$		13	20	mA
$I_{CCR}$		$DE = \overline{RE} = 0\text{V}$				5	8	mA
$I_{CCZ}$		$DE = 0\text{V}$ , $\overline{RE} = V_{CC}$				3	7.5	mA
$I_{CC}$		$DE = V_{CC}$ , $\overline{RE} = 0\text{V}$ , $R_L = 27\Omega$				16	22	mA
$C_{output}$	Capacitance @ BUS Pins			DO+/RI+, DO-/RI-		5		pF

- (1) All currents into device pins are positive; all currents out of device pins are negative. All voltages are referenced to device ground except  $V_{OD}$ ,  $V_{ID}$ ,  $V_{TH}$  and  $V_{TL}$  unless otherwise specified.
- (2) All typicals are given for  $V_{CC} = +3.3\text{V}$  or  $5.0\text{V}$  and  $T_A = +25^{\circ}\text{C}$ , unless otherwise stated.

**5V DC ELECTRICAL CHARACTERISTICS** <sup>(1)(2)</sup>
 $T_A = -40^\circ\text{C}$  to  $+85^\circ\text{C}$  unless otherwise noted,  $V_{CC} = 5.0\text{V} \pm 0.5\text{V}$ 

Parameter		Test Conditions		Pin	Min	Typ	Max	Units
$V_{OD}$	Output Differential Voltage	$R_L = 27\Omega$ , See <a href="#">Figure 3</a>		DO+/RI+, DO-/RI-	145	270	390	mV
$\Delta V_{OD}$	$V_{OD}$ Magnitude Change					3	30	mV
$V_{OS}$	Offset Voltage				1	1.35	1.65	V
$\Delta V_{OS}$	Offset Magnitude Change					5	50	mV
$I_{OSD}$	Output Short Circuit Current	$V_O = 0\text{V}$ , $DE = V_{CC}$				-12	-20	mA
$V_{OH}$	Voltage Output High	$V_{ID} = +100\text{mV}$	$I_{OH} = -400\mu\text{A}$	R <sub>OUT</sub>	4.3	5.0		V
		Inputs Open			4.3	5.0		V
		Inputs Shorted			4.3	5.0		V
		Inputs Terminated, $R_L = 27\Omega$			4.3	5.0		V
$V_{OL}$	Voltage Output Low	$I_{OL} = 2.0\text{mA}$ , $V_{ID} = -100\text{mV}$				0.1	0.4	V
$I_{OS}$	Output Short Circuit Current	$V_{OUT} = 0\text{V}$ , $V_{ID} = +100\text{mV}$			-35	-90	-130	mA
$V_{TH}$	Input Threshold High	$DE = 0\text{V}$		DO+/RI+, DO-/RI-			+100	mV
$V_{TL}$	Input Threshold Low					-100		mV
$I_{IN}$	Input Current	$DE = 0\text{V}$ , $V_{IN} = +2.4\text{V}$ , or $0\text{V}$			-20	$\pm 1$	+20	$\mu\text{A}$
		$V_{CC} = 0\text{V}$ , $V_{IN} = +2.4\text{V}$ , or $0\text{V}$			-20	$\pm 1$	+20	$\mu\text{A}$
$V_{IH}$	Minimum Input High Voltage			DIN, DE, RE	2.0		$V_{CC}$	V
$V_{IL}$	Maximum Input Low Voltage					GND		0.8
$I_{IH}$	Input High Current	$V_{IN} = V_{CC}$ or $2.4\text{V}$				$\pm 1$	$\pm 10$	$\mu\text{A}$
$I_{IL}$	Input Low Current	$V_{IN} = \text{GND}$ or $0.4\text{V}$				$\pm 1$	$\pm 10$	$\mu\text{A}$
$V_{CL}$	Input Diode Clamp Voltage	$I_{CLAMP} = -18\text{mA}$			-1.5	-0.8		V
$I_{CCD}$	Power Supply Current	$DE = \overline{RE} = V_{CC}$ , $R_L = 27\Omega$		$V_{CC}$		17	25	mA
$I_{CCR}$		$DE = \overline{RE} = 0\text{V}$				6	10	mA
$I_{CCZ}$		$DE = 0\text{V}$ , $\overline{RE} = V_{CC}$				3	8	mA
$I_{CC}$		$DE = V_{CC}$ , $\overline{RE} = 0\text{V}$ , $R_L = 27\Omega$				20	25	mA
$C_{\text{output}}$	Capacitance @ BUS Pins			DO+/RI+, DO-/RI-		5		pF

- (1) All currents into device pins are positive; all currents out of device pins are negative. All voltages are referenced to device ground except  $V_{OD}$ ,  $V_{ID}$ ,  $V_{TH}$  and  $V_{TL}$  unless otherwise specified.
- (2) All typicals are given for  $V_{CC} = +3.3\text{V}$  or  $5.0\text{V}$  and  $T_A = +25^\circ\text{C}$ , unless otherwise stated.

### 3.3V AC ELECTRICAL CHARACTERISTICS <sup>(1)</sup>

 $T_A = -40^{\circ}\text{C to } +85^{\circ}\text{C}, V_{CC} = 3.3\text{V} \pm 0.3\text{V}$ 

Parameter		Test Conditions	Min	Typ	Max	Units
<b>DIFFERENTIAL DRIVER TIMING REQUIREMENTS</b>						
$t_{PHLD}$	Differential Prop. Delay High to Low	$R_L = 27\Omega$ , See <a href="#">Figure 4</a> and <a href="#">Figure 5</a> $C_L = 10\text{ pF}$	1.0	3.0	5.0	ns
$t_{PLHD}$	Differential Prop. Delay Low to High		1.0	2.8	5.0	ns
$t_{SKD}$	Differential SKEW $ t_{PHLD} - t_{PLHD} $			0.2	1.0	ns
$t_{TLH}$	Transition Time Low to High			0.3	2.0	ns
$t_{THL}$	Transition Time High to Low			0.3	2.0	ns
$t_{PHZ}$	Disable Time High to Z	$R_L = 27\Omega$ , See <a href="#">Figure 6</a> and <a href="#">Figure 7</a> $C_L = 10\text{ pF}$	0.5	4.5	9.0	ns
$t_{PLZ}$	Disable Time Low to Z		0.5	5.0	10.0	ns
$t_{PZH}$	Enable Time Z to High		2.0	5.0	7.0	ns
$t_{PZL}$	Enable Time Z to Low		1.0	4.5	9.0	ns
<b>DIFFERENTIAL RECEIVER TIMING REQUIREMENTS</b>						
$t_{PHLD}$	Differential Prop. Delay High to Low	See <a href="#">Figure 8</a> and <a href="#">Figure 9</a> $C_L = 10\text{ pF}$	2.5	5.0	12.0	ns
$t_{PLHD}$	Differential Prop. Delay Low to High		2.5	5.5	10.0	ns
$t_{SKD}$	Differential SKEW $ t_{PHLD} - t_{PLHD} $			0.5	2.0	ns
$t_r$	Rise Time			1.5	4.0	ns
$t_f$	Fall Time			1.5	4.0	ns
$t_{PHZ}$	Disable Time High to Z	$R_L = 500\Omega$ , See <a href="#">Figure 10</a> and <a href="#">Figure 11</a> $C_L = 10\text{ pF}^{(2)}$	2.0	4.0	6.0	ns
$t_{PLZ}$	Disable Time Low to Z		2.0	5.0	7.0	ns
$t_{PZH}$	Enable Time Z to High		2.0	7.0	13.0	ns
$t_{PZL}$	Enable Time Z to Low		2.0	6.0	10.0	ns

- (1) Generator waveforms for all tests unless otherwise specified:  $f = 1\text{MHz}$ ,  $Z_O = 50\Omega$ ,  $t_r, t_f \leq 6.0\text{ns}$  (0%–100%) on control pins and  $\leq 1.0\text{ns}$  for RI inputs.
- (2) For receiver tri-state delays, the switch is set to  $V_{CC}$  for  $t_{PZL}$ , and  $t_{PLZ}$  and to GND for  $t_{PZH}$ , and  $t_{PHZ}$ .

### 5V AC ELECTRICAL CHARACTERISTICS (1)

T<sub>A</sub> = -40°C to +85°C, V<sub>CC</sub> = 5.0V ± 0.5V

Parameter	Test Conditions	Min	Typ	Max	Units		
<b>DIFFERENTIAL DRIVER TIMING REQUIREMENTS</b>							
t <sub>PHLD</sub>	Differential Prop. Delay High to Low	R <sub>L</sub> = 27Ω, See Figure 4 and Figure 5 C <sub>L</sub> = 10 pF		0.5	2.7	4.5	ns
t <sub>PLHD</sub>	Differential Prop. Delay Low to High			0.5	2.5	4.5	ns
t <sub>SKD</sub>	Differential SKEW  t <sub>PHLD</sub> - t <sub>PLHD</sub>				0.2	1.0	ns
t <sub>TLH</sub>	Transition Time Low to High				0.3	2.0	ns
t <sub>THL</sub>	Transition Time High to Low				0.3	2.0	ns
t <sub>PHZ</sub>	Disable Time High to Z	R <sub>L</sub> = 27Ω, See Figure 6 and Figure 7 C <sub>L</sub> = 10 pF		0.5	3.0	7.0	ns
t <sub>PLZ</sub>	Disable Time Low to Z			0.5	5.0	10.0	ns
t <sub>PZH</sub>	Enable Time Z to High			2.0	4.0	7.0	ns
t <sub>PZL</sub>	Enable Time Z to Low			1.0	4.0	9.0	ns
<b>DIFFERENTIAL RECEIVER TIMING REQUIREMENTS</b>							
t <sub>PHLD</sub>	Differential Prop. Delay High to Low	See Figure 8 and Figure 9 C <sub>L</sub> = 10 pF		2.5	5.0	12.0	ns
t <sub>PLHD</sub>	Differential Prop. Delay Low to High			2.5	4.6	10.0	ns
t <sub>SKD</sub>	Differential SKEW  t <sub>PHLD</sub> - t <sub>PLHD</sub>				0.4	2.0	ns
t <sub>r</sub>	Rise Time				1.2	2.5	ns
t <sub>f</sub>	Fall Time				1.2	2.5	ns
t <sub>PHZ</sub>	Disable Time High to Z	R <sub>L</sub> = 500Ω, See Figure 10 and Figure 11 C <sub>L</sub> = 10 pF <sup>(2)</sup>		2.0	4.0	6.0	ns
t <sub>PLZ</sub>	Disable Time Low to Z			2.0	4.0	6.0	ns
t <sub>PZH</sub>	Enable Time Z to High			2.0	5.0	9.0	ns
t <sub>PZL</sub>	Enable Time Z to Low			2.0	5.0	7.0	ns

- (1) Generator waveforms for all tests unless otherwise specified: f = 1MHz, Z<sub>O</sub> = 50Ω, t<sub>r</sub>, t<sub>f</sub> ≤ 6.0ns (0%–100%) on control pins and ≤ 1.0ns for RI inputs.
- (2) For receiver tri-state delays, the switch is set to V<sub>CC</sub> for t<sub>PZL</sub>, and t<sub>PLZ</sub> and to GND for t<sub>PZH</sub>, and t<sub>PHZ</sub>.

### TEST CIRCUITS AND TIMING WAVEFORMS

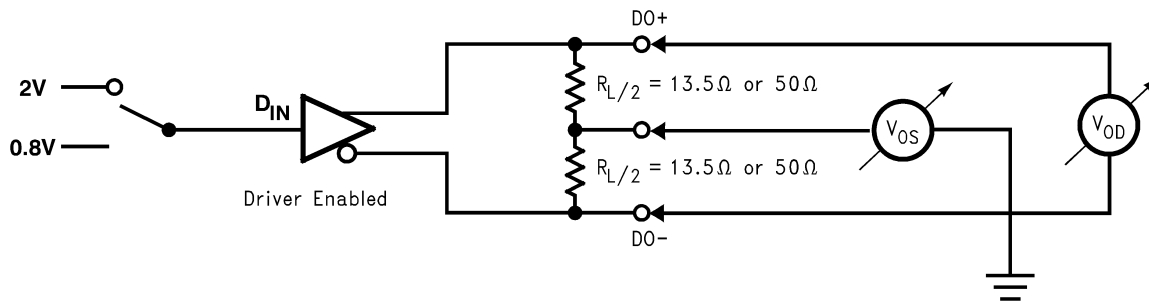

Figure 3. Differential Driver DC Test Circuit

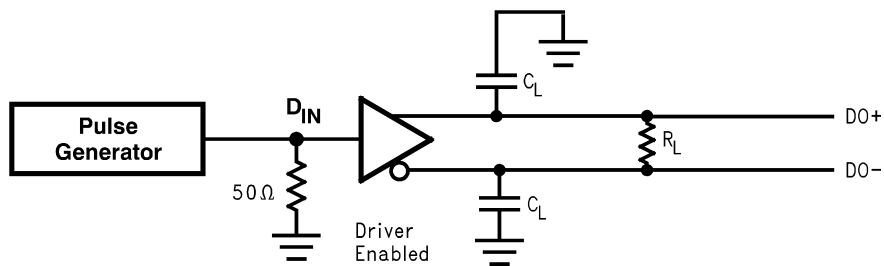

Figure 4. Differential Driver Propagation Delay and Transition Time Test Circuit

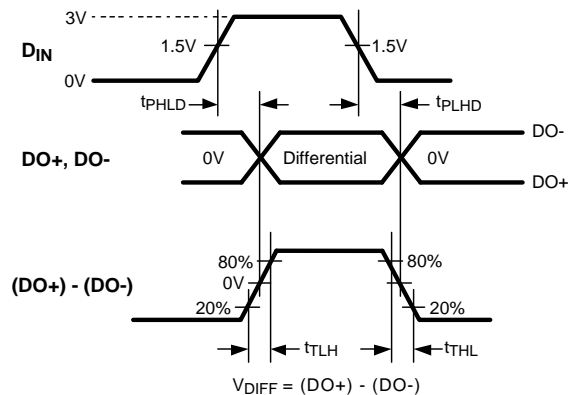

Figure 5. Differential Driver Propagation Delay and Transition Time Waveforms

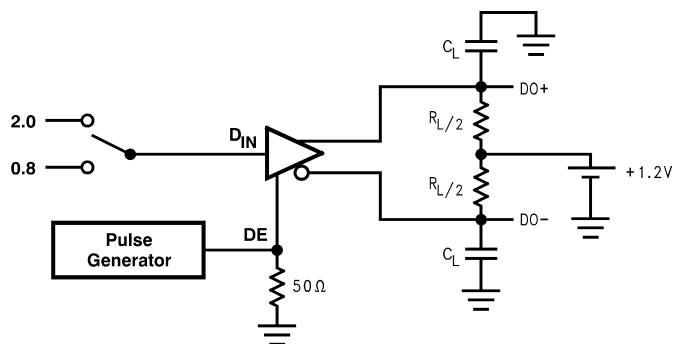

Figure 6. Driver TRI-STATE Delay Test Circuit

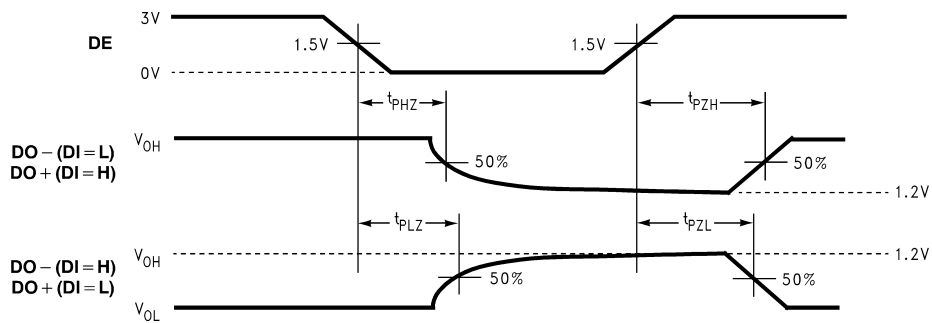

Figure 7. Driver TRI-STATE Delay Waveforms

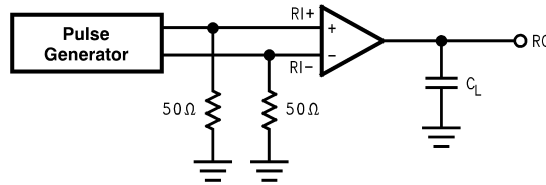

Figure 8. Receiver Propagation Delay and Transition Time Test Circuit

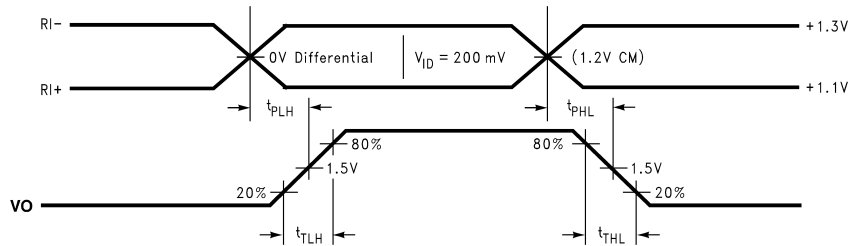

Figure 9. Receiver Propagation Delay and Transition Time Waveforms

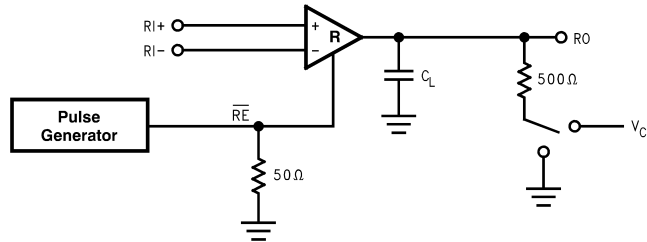

Figure 10. Receiver TRI-STATE Delay Test Circuit

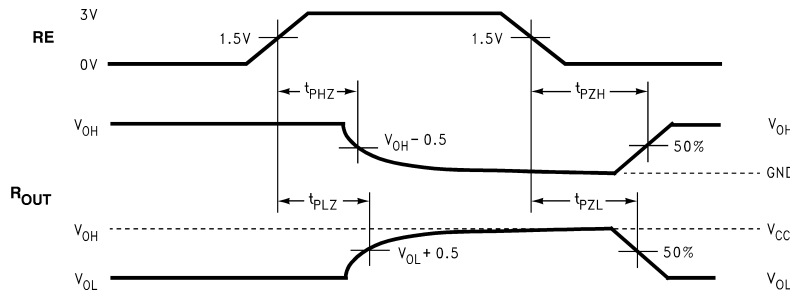

Figure 11. Receiver TRI-STATE Delay Waveforms TRI-STATE Delay Waveforms

TYPICAL BUS APPLICATION CONFIGURATIONS

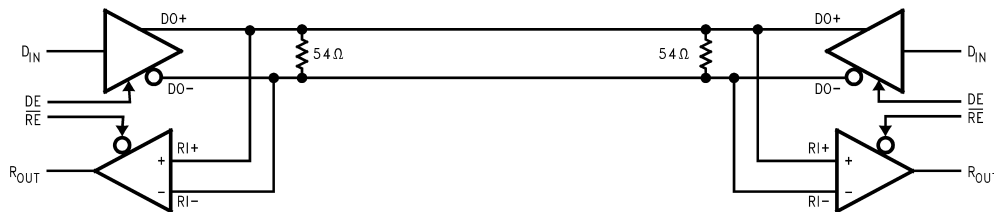

Figure 12. Bi-Directional Half-Duplex Point-to-Point Applications

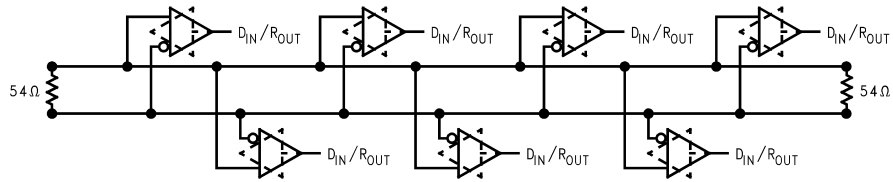

Figure 13. Multi-Point Bus Applications

## APPLICATION INFORMATION

There are a few common practices which should be implied when designing PCB for BLVDS signaling. Recommended practices are:

- Use at least 4 layer PCB board (BLVDS signals, ground, power and TTL signals).
- Keep drivers and receivers as close to the (BLVDS port side) connector as possible.
- Bypass each BLVDS device and also use distributed bulk capacitance. Surface mount capacitors placed close to power and ground pins work best. Two or three multi-layer ceramic (MLC) surface mount capacitors (0.1  $\mu$ F, and 0.01  $\mu$ F in parallel should be used between each  $V_{CC}$  and ground. The capacitors should be as close as possible to the  $V_{CC}$  pin.
- Use the termination resistor which best matches the differential impedance of your transmission line.
- Leave unused LVDS receiver inputs open (floating)

**Table 1. Functional Table**

MODE SELECTED	DE	$\overline{RE}$
DRIVER MODE	H	H
RECEIVER MODE	L	L
TRI-STATE MODE	L	H
LOOP BACK MODE	H	L

**Table 2. Transmitter Mode<sup>(1)</sup>**

INPUTS		OUTPUTS	
DE	DI	DO+	DO-
H	L	L	H
H	H	H	L
H	$2 > \& > 0.8$	X	X
L	X	Z	Z

- (1) L = Low state  
H = High state

**Table 3. Receiver Mode<sup>(1)</sup>**

INPUTS		OUTPUT
$\overline{RE}$	(RI+)-(RI-)	
L	L (< -100 mV)	L
L	H (> +100 mV)	H
L	$100 \text{ mV} > \& > -100 \text{ mV}$	X
H	X	Z

- (1) X = High or Low logic state  
Z = High impedance state  
L = Low state  
H = High state

**Table 4. Device Pin Descriptions**

Pin Name	Pin No.	Input/Output	Description
DIN	2	I	TTL Driver Input
DO $\pm$ /RI $\pm$	6, 7	I/O	LVDS Driver Outputs/LVDS Receiver Inputs
R <sub>OUT</sub>	3	O	TTL Receiver Output
$\overline{RE}$	5	I	Receiver Enable TTL Input (Active Low)
DE	1	I	Driver Enable TTL Input (Active High)
GND	4	NA	Ground
V <sub>CC</sub>	8	NA	Power Supply

---

**REVISION HISTORY**

<b>Changes from Revision D (April 2013) to Revision E</b>	<b>Page</b>
<hr/> <ul style="list-style-type: none"><li>• Changed layout of National Data Sheet to TI format .....</li></ul>	<hr/> <a href="#">10</a>

**PACKAGING INFORMATION**

Orderable Device	Status (1)	Package Type	Package Drawing	Pins	Package Qty	Eco Plan (2)	Lead/Ball Finish (6)	MSL Peak Temp (3)	Op Temp (°C)	Device Marking (4/5)	Samples
DS92LV010ATM	NRND	SOIC	D	8	95	TBD	Call TI	Call TI	-40 to 85	LV010 ATM	
DS92LV010ATM/NOPB	ACTIVE	SOIC	D	8	95	Green (RoHS & no Sb/Br)	CU SN	Level-1-260C-UNLIM	-40 to 85	LV010 ATM	Samples
DS92LV010ATMX	NRND	SOIC	D	8	2500	TBD	Call TI	Call TI	-40 to 85	LV010 ATM	
DS92LV010ATMX/NOPB	ACTIVE	SOIC	D	8	2500	Green (RoHS & no Sb/Br)	CU SN	Level-1-260C-UNLIM	-40 to 85	LV010 ATM	Samples

(1) The marketing status values are defined as follows:

**ACTIVE:** Product device recommended for new designs.

**LIFEBUY:** TI has announced that the device will be discontinued, and a lifetime-buy period is in effect.

**NRND:** Not recommended for new designs. Device is in production to support existing customers, but TI does not recommend using this part in a new design.

**PREVIEW:** Device has been announced but is not in production. Samples may or may not be available.

**OBSOLETE:** TI has discontinued the production of the device.

(2) Eco Plan - The planned eco-friendly classification: Pb-Free (RoHS), Pb-Free (RoHS Exempt), or Green (RoHS & no Sb/Br) - please check <http://www.ti.com/productcontent> for the latest availability information and additional product content details.

**TBD:** The Pb-Free/Green conversion plan has not been defined.

**Pb-Free (RoHS):** TI's terms "Lead-Free" or "Pb-Free" mean semiconductor products that are compatible with the current RoHS requirements for all 6 substances, including the requirement that lead not exceed 0.1% by weight in homogeneous materials. Where designed to be soldered at high temperatures, TI Pb-Free products are suitable for use in specified lead-free processes.

**Pb-Free (RoHS Exempt):** This component has a RoHS exemption for either 1) lead-based flip-chip solder bumps used between the die and package, or 2) lead-based die adhesive used between the die and leadframe. The component is otherwise considered Pb-Free (RoHS compatible) as defined above.

**Green (RoHS & no Sb/Br):** TI defines "Green" to mean Pb-Free (RoHS compatible), and free of Bromine (Br) and Antimony (Sb) based flame retardants (Br or Sb do not exceed 0.1% by weight in homogeneous material)

(3) MSL, Peak Temp. - The Moisture Sensitivity Level rating according to the JEDEC industry standard classifications, and peak solder temperature.

(4) There may be additional marking, which relates to the logo, the lot trace code information, or the environmental category on the device.

(5) Multiple Device Markings will be inside parentheses. Only one Device Marking contained in parentheses and separated by a "~" will appear on a device. If a line is indented then it is a continuation of the previous line and the two combined represent the entire Device Marking for that device.

(6) Lead/Ball Finish - Orderable Devices may have multiple material finish options. Finish options are separated by a vertical ruled line. Lead/Ball Finish values may wrap to two lines if the finish value exceeds the maximum column width.

**Important Information and Disclaimer:** The information provided on this page represents TI's knowledge and belief as of the date that it is provided. TI bases its knowledge and belief on information provided by third parties, and makes no representation or warranty as to the accuracy of such information. Efforts are underway to better integrate information from third parties. TI has taken and continues to take reasonable steps to provide representative and accurate information but may not have conducted destructive testing or chemical analysis on incoming materials and chemicals. TI and TI suppliers consider certain information to be proprietary, and thus CAS numbers and other limited information may not be available for release.

In no event shall TI's liability arising out of such information exceed the total purchase price of the TI part(s) at issue in this document sold by TI to Customer on an annual basis.

## TAPE AND REEL INFORMATION



### QUADRANT ASSIGNMENTS FOR PIN 1 ORIENTATION IN TAPE



\*All dimensions are nominal

Device	Package Type	Package Drawing	Pins	SPQ	Reel Diameter (mm)	Reel Width W1 (mm)	A0 (mm)	B0 (mm)	K0 (mm)	P1 (mm)	W (mm)	Pin1 Quadrant
DS92LV010ATMX	SOIC	D	8	2500	330.0	12.4	6.5	5.4	2.0	8.0	12.0	Q1
DS92LV010ATMX/NOPB	SOIC	D	8	2500	330.0	12.4	6.5	5.4	2.0	8.0	12.0	Q1

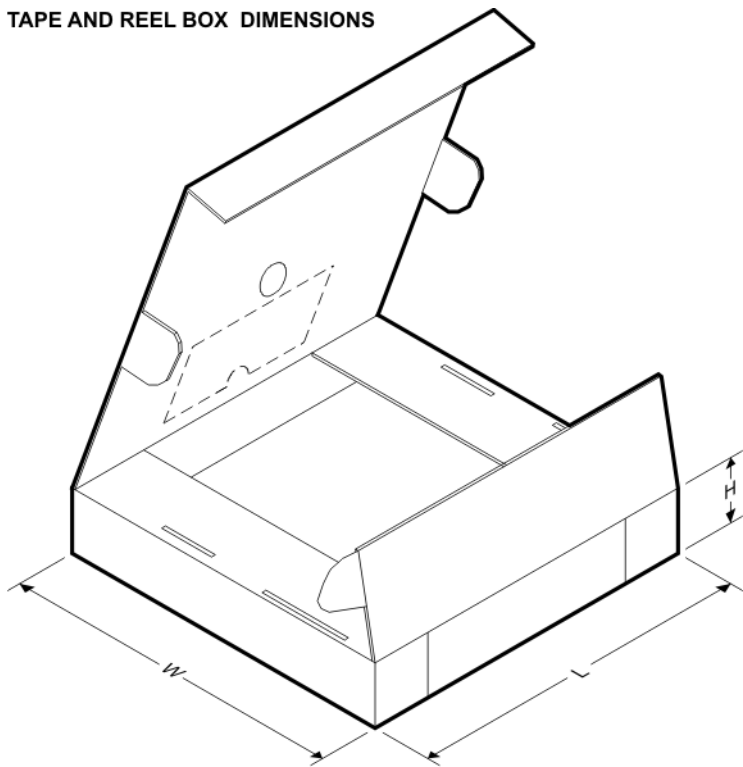
**TAPE AND REEL BOX DIMENSIONS**

\*All dimensions are nominal

Device	Package Type	Package Drawing	Pins	SPQ	Length (mm)	Width (mm)	Height (mm)
DS92LV010ATMX	SOIC	D	8	2500	367.0	367.0	35.0
DS92LV010ATMX/NOPB	SOIC	D	8	2500	367.0	367.0	35.0



D0008A

# PACKAGE OUTLINE

SOIC - 1.75 mm max height

SMALL OUTLINE INTEGRATED CIRCUIT



4214825/C 02/2019

### NOTES:

1. Linear dimensions are in inches [millimeters]. Dimensions in parenthesis are for reference only. Controlling dimensions are in inches. Dimensioning and tolerancing per ASME Y14.5M.
2. This drawing is subject to change without notice.
3. This dimension does not include mold flash, protrusions, or gate burrs. Mold flash, protrusions, or gate burrs shall not exceed  $.006$  [0.15] per side.
4. This dimension does not include interlead flash.
5. Reference JEDEC registration MS-012, variation AA.

# EXAMPLE BOARD LAYOUT

D0008A

SOIC - 1.75 mm max height

SMALL OUTLINE INTEGRATED CIRCUIT



LAND PATTERN EXAMPLE  
 EXPOSED METAL SHOWN  
 SCALE:8X



SOLDER MASK DETAILS

4214825/C 02/2019

NOTES: (continued)

- 6. Publication IPC-7351 may have alternate designs.
- 7. Solder mask tolerances between and around signal pads can vary based on board fabrication site.

# EXAMPLE STENCIL DESIGN

D0008A

SOIC - 1.75 mm max height

SMALL OUTLINE INTEGRATED CIRCUIT



SOLDER PASTE EXAMPLE  
BASED ON .005 INCH [0.125 MM] THICK STENCIL  
SCALE:8X

4214825/C 02/2019

NOTES: (continued)

8. Laser cutting apertures with trapezoidal walls and rounded corners may offer better paste release. IPC-7525 may have alternate design recommendations.
9. Board assembly site may have different recommendations for stencil design.

## IMPORTANT NOTICE AND DISCLAIMER

TI PROVIDES TECHNICAL AND RELIABILITY DATA (INCLUDING DATASHEETS), DESIGN RESOURCES (INCLUDING REFERENCE DESIGNS), APPLICATION OR OTHER DESIGN ADVICE, WEB TOOLS, SAFETY INFORMATION, AND OTHER RESOURCES "AS IS" AND WITH ALL FAULTS, AND DISCLAIMS ALL WARRANTIES, EXPRESS AND IMPLIED, INCLUDING WITHOUT LIMITATION ANY IMPLIED WARRANTIES OF MERCHANTABILITY, FITNESS FOR A PARTICULAR PURPOSE OR NON-INFRINGEMENT OF THIRD PARTY INTELLECTUAL PROPERTY RIGHTS.

These resources are intended for skilled developers designing with TI products. You are solely responsible for (1) selecting the appropriate TI products for your application, (2) designing, validating and testing your application, and (3) ensuring your application meets applicable standards, and any other safety, security, or other requirements. These resources are subject to change without notice. TI grants you permission to use these resources only for development of an application that uses the TI products described in the resource. Other reproduction and display of these resources is prohibited. No license is granted to any other TI intellectual property right or to any third party intellectual property right. TI disclaims responsibility for, and you will fully indemnify TI and its representatives against, any claims, damages, costs, losses, and liabilities arising out of your use of these resources.

TI's products are provided subject to TI's Terms of Sale ([www.ti.com/legal/termsofsale.html](http://www.ti.com/legal/termsofsale.html)) or other applicable terms available either on [ti.com](http://ti.com) or provided in conjunction with such TI products. TI's provision of these resources does not expand or otherwise alter TI's applicable warranties or warranty disclaimers for TI products.

Mailing Address: Texas Instruments, Post Office Box 655303, Dallas, Texas 75265  
Copyright © 2019, Texas Instruments Incorporated

## Looking for pricing, stock, or lifecycle information?

Click below to explore more details on WIN SOURCE:

 [View DS92LV010ATM/NOPB on WIN SOURCE](#)

 [Texas Instruments](#) Information

## Optimize Your Supply Chain with WIN SOURCE Solutions

-  Global Sourcing Solution
-  Obsolete Management
-  Cost Control Management
-  Shortage Management
-  Alternative Solution
-  Excess Inventory Management