



**THE DATASHEET OF
DS91C176TMA**



DS91D176/DS91C176 100 MHz Single Channel M-LVDS Transceivers

Check for Samples: [DS91C176](#), [DS91D176](#)

FEATURES

- DC to 100+ MHz / 200+ Mbps Low Power, Low EMI Operation
- Optimal for ATCA, uTCA Clock Distribution Networks
- Meets or Exceeds TIA/EIA-899 M-LVDS Standard
- Wide Input Common Mode Voltage for Increased Noise Immunity
- DS91D176 has Type 1 Receiver Input
- DS91C176 has Type 2 Receiver with Fail-safe
- Industrial Temperature Range
- Space Saving SOIC-8 Package

DESCRIPTION

The DS91C176 and DS91D176 are 100 MHz single channel M-LVDS (Multipoint Low Voltage Differential Signaling) transceivers designed for applications that utilize multipoint networks (e.g. clock distribution in ATCA and uTCA based systems). M-LVDS is a new bus interface standard (TIA/EIA-899) optimized for multidrop networks. Controlled edge rates, tight input receiver thresholds and increased drive strength are some of the key enhancements that make M-LVDS devices an ideal choice for distributing signals via multipoint networks.

The DS91C176/DS91D176 are half-duplex transceivers that accept LVTTTL/LVCMOS signals at the driver inputs and convert them to differential M-LVDS signals. The receiver inputs accept low voltage differential signals (LVDS, B-LVDS, M-LVDS, LVPECL and CML) and convert them to 3V LVCMOS signals. The DS91D176 has a M-LVDS type 1 receiver input with no offset. The DS91C176 has an M-LVDS type 2 receiver which enable failsafe functionality.

Typical Application in an ATCA Clock Distribution Network

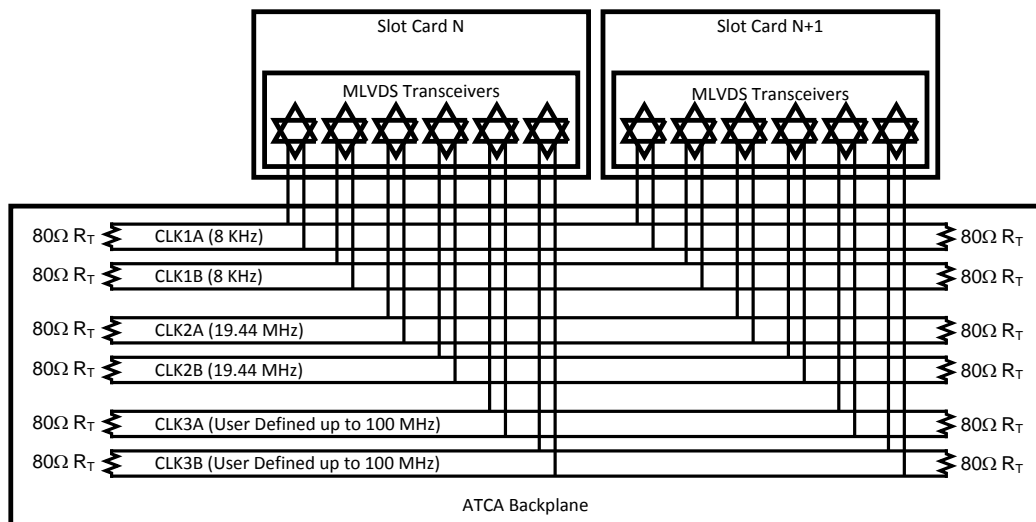
Figure 1. System Diagram

Please be aware that an important notice concerning availability, standard warranty, and use in critical applications of Texas Instruments semiconductor products and disclaimers thereto appears at the end of this data sheet.

All trademarks are the property of their respective owners.

Connection and Logic Diagram

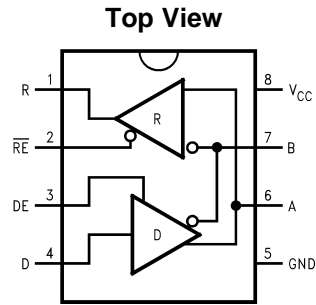

Figure 2. SOIC Package
See Package Number D0008A

M-LVDS Receiver Types

The EIA/TIA-899 M-LVDS standard specifies two different types of receiver input stages. A type 1 receiver has a conventional threshold that is centered at the midpoint of the input amplitude, $V_{ID}/2$. A type 2 receiver has a built in offset that is 100mV greater than $V_{ID}/2$. The type 2 receiver offset acts as a failsafe circuit where open or short circuits at the input will always result in the output stage being driven to a low logic state.

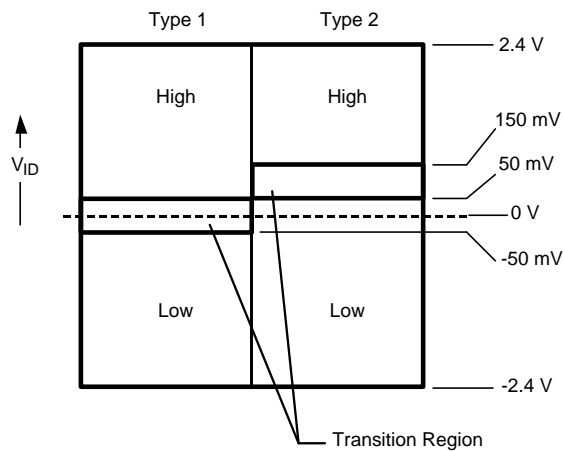

Figure 3. M-LVDS Receiver Input Thresholds



These devices have limited built-in ESD protection. The leads should be shorted together or the device placed in conductive foam during storage or handling to prevent electrostatic damage to the MOS gates.

Absolute Maximum Ratings ⁽¹⁾⁽²⁾

Supply Voltage, V_{CC}	-0.3V to +4V
Control Input Voltages	-0.3V to ($V_{CC} + 0.3V$)
Driver Input Voltage	-0.3V to ($V_{CC} + 0.3V$)
Driver Output Voltages	-1.8V to +4.1V
Receiver Input Voltages	-1.8V to +4.1V
Receiver Output Voltage	-0.3V to ($V_{CC} + 0.3V$)
Maximum Package Power Dissipation at +25°C	
SOIC Package	833 mW
Derate SOIC Package	6.67 mW/°C above +25°C
Thermal Resistance (4-Layer, 2 oz. Cu, JEDEC)	
θ_{JA}	150°C/W
θ_{JC}	63°C/W
Maximum Junction Temperature	150°C
Storage Temperature Range	-65°C to +150°C
Lead Temperature (Soldering, 4 seconds)	260°C
ESD Ratings: (HBM 1.5k Ω , 100pF)	
	≥ 8 kV
(EIAJ 0 Ω , 200pF)	
	≥ 250 V
(CDM 0 Ω , 0pF)	
	≥ 1000 V

- (1) "Absolute Maximum Ratings" are those beyond which the safety of the device cannot be verified. They are not meant to imply that the device should be operated at these limits. The tables of "Electrical Characteristics" provide conditions for actual device operation.
- (2) If Military/Aerospace specified devices are required, please contact the TI Sales Office/Distributors for availability and specifications.

Recommended Operating Conditions

	Min	Typ	Max	Units
Supply Voltage, V_{CC}	3.0	3.3	3.6	V
Voltage at Any Bus Terminal (Separate or Common-Mode)	-1.4		+3.8	V
Differential Input Voltage V_{ID}			2.4	V
LVTTTL Input Voltage High V_{IH}	2.0		V_{CC}	V
LVTTTL Input Voltage Low V_{IL}	0		0.8	V
Operating Free Air Temperature T_A	-40	+25	+85	°C

Electrical Characteristics

 Over recommended operating supply and temperature ranges unless otherwise specified. ^{(1) (2) (3) (4)}

Parameter		Test Conditions	Min	Typ	Max	Units
M-LVDS Driver						
$ V_{AB} $	Differential output voltage magnitude	$R_L = 50\Omega$, $C_L = 5pF$ See Figure 4 and Figure 6	480		650	mV
ΔV_{AB}	Change in differential output voltage magnitude between logic states		-50	0	+50	mV
$V_{OS(SS)}$	Steady-state common-mode output voltage	$R_L = 50\Omega$, $C_L = 5pF$ See Figure 4 and Figure 5 ($V_{OS(PP)}$ @ 500KHz clock)	0.3	1.8	2.1	V
$ \Delta V_{OS(SS)} $	Change in steady-state common-mode output voltage between logic states		0		+50	mV
$V_{OS(PP)}$	Peak-to-peak common-mode output voltage			135		mV
$V_{A(OC)}$	Maximum steady-state open-circuit output voltage	See Figure 7	0		2.4	V
$V_{B(OC)}$	Maximum steady-state open-circuit output voltage		0		2.4	V

- (1) All currents into device pins are positive; all currents out of device pins are negative. All voltages are referenced to device ground unless otherwise specified.
- (2) All typicals are given for $V_{CC} = 3.3V$ and $T_A = 25^\circ C$.
- (3) The algebraic convention, in which the least positive (most negative) limit is designated as minimum, is used in this datasheet.
- (4) C_L includes fixture capacitance and C_D includes probe capacitance.

Electrical Characteristics (continued)

Over recommended operating supply and temperature ranges unless otherwise specified. ⁽¹⁾ ⁽²⁾ ⁽³⁾ ⁽⁴⁾

Parameter		Test Conditions	Min	Typ	Max	Units	
V _{P(H)}	Voltage overshoot, low-to-high level output	R _L = 50Ω, C _L = 5pF, C _D = 0.5pF			1.2V _{SS}	V	
V _{P(L)}	Voltage overshoot, high-to-low level output	See Figure 9 and Figure 10 ⁽⁵⁾	-0.2V _{SS}			V	
I _{IH}	High-level input current (LVTTTL inputs)	V _{IH} = 2.0V	-15		15	μA	
I _{IL}	Low-level input current (LVTTTL inputs)	V _{IL} = 0.8V	-15		15	μA	
V _{IKL}	Input Clamp Voltage (LVTTTL inputs)	I _{IN} = -18mA	-1.5			V	
I _{OS}	Differential short-circuit output current	See Figure 8	-43		43	mA	
M-LVDS Receiver							
V _{IT+}	Positive-going differential input voltage threshold	See FUNCTION TABLES	Type 1		20	50	mV
			Type 2		94	150	mV
V _{IT-}	Negative-going differential input voltage threshold	See FUNCTION TABLES	Type 1	-50	20		mV
			Type 2	50	94		mV
V _{OH}	High-level output voltage (LVTTTL output)	I _{OH} = -8mA	2.4	2.7		V	
V _{OL}	Low-level output voltage (LVTTTL output)	I _{OL} = 8mA		0.28	0.4	V	
I _{OZ}	TRI-STATE output current	V _O = 0V or 3.6V	-10		10	μA	
I _{OSR}	Short-circuit receiver output current (LVTTTL output)	V _O = 0V		-48	-90	mA	
M-LVDS Bus (Input and Output) Pins							
I _A	Transceiver input/output current	V _A = 3.8V, V _B = 1.2V			32	μA	
		V _A = 0V or 2.4V, V _B = 1.2V	-20		+20	μA	
		V _A = -1.4V, V _B = 1.2V	-32			μA	
I _B	Transceiver input/output current	V _B = 3.8V, V _A = 1.2V			32	μA	
		V _B = 0V or 2.4V, V _A = 1.2V	-20		+20	μA	
		V _B = -1.4V, V _A = 1.2V	-32			μA	
I _{AB}	Transceiver input/output differential current (I _A - I _B)	V _A = V _B , -1.4V ≤ V ≤ 3.8V	-4		+4	μA	
I _{A(OFF)}	Transceiver input/output power-off current	V _A = 3.8V, V _B = 1.2V, DE = V _{CC} 0V ≤ V _{CC} ≤ 1.5V			32	μA	
		V _A = 0V or 2.4V, V _B = 1.2V, DE = V _{CC} 0V ≤ V _{CC} ≤ 1.5V	-20		+20	μA	
		V _A = -1.4V, V _B = 1.2V, DE = V _{CC} 0V ≤ V _{CC} ≤ 1.5V	-32			μA	
I _{B(OFF)}	Transceiver input/output power-off current	V _B = 3.8V, V _A = 1.2V, DE = V _{CC} 0V ≤ V _{CC} ≤ 1.5V			32	μA	
		V _B = 0V or 2.4V, V _A = 1.2V, DE = V _{CC} 0V ≤ V _{CC} ≤ 1.5V	-20		+20	μA	
		V _B = -1.4V, V _A = 1.2V, DE = V _{CC} 0V ≤ V _{CC} ≤ 1.5V	-32			μA	
I _{AB(OFF)}	Transceiver input/output power-off differential current (I _{A(OFF)} - I _{B(OFF)})	V _A = V _B , -1.4V ≤ V ≤ 3.8V, DE = V _{CC} 0V ≤ V _{CC} ≤ 1.5V	-4		+4	μA	
C _A	Transceiver input/output capacitance	V _{CC} = OPEN		9		pF	
C _B	Transceiver input/output capacitance			9		pF	
C _{AB}	Transceiver input/output differential capacitance			5.7		pF	
C _{A/B}	Transceiver input/output capacitance balance (C _A /C _B)			1.0			

(5) Not production tested. Specified by a statistical analysis on a sample basis at the time of characterization.

Electrical Characteristics (continued)

Over recommended operating supply and temperature ranges unless otherwise specified. ⁽¹⁾ ⁽²⁾ ⁽³⁾ ⁽⁴⁾

Parameter		Test Conditions	Min	Typ	Max	Units
SUPPLY CURRENT (V_{CC})						
I _{CCD}	Driver Supply Current	R _L = 50Ω, DE = V _{CC} , $\overline{RE} = V_{CC}$		20	29.5	mA
I _{CCZ}	TRI-STATE Supply Current	DE = GND, $\overline{RE} = V_{CC}$		6	9.0	mA
I _{CCR}	Receiver Supply Current	DE = GND, $\overline{RE} = GND$		14	18.5	mA

Switching Characteristics

Over recommended operating supply and temperature ranges unless otherwise specified. ⁽¹⁾ ⁽²⁾

Parameter		Test Conditions	Min	Typ	Max	Units
DRIVER AC SPECIFICATION						
t _{PLH}	Differential Propagation Delay Low to High	R _L = 50Ω, C _L = 5 pF, C _D = 0.5 pF Figure 9 and Figure 10	1.3	3.4	5.0	ns
t _{PHL}	Differential Propagation Delay High to Low		1.3	3.1	5.0	ns
t _{SKD1} (t _{sk(p)})	Pulse Skew t _{PLHD} - t _{PHLD} ⁽³⁾ ⁽⁴⁾			300	420	ps
t _{SKD3}	Part-to-Part Skew ⁽⁵⁾ ⁽⁵⁾				1.3	ns
t _{TLH} (t _r)	Rise Time ⁽⁴⁾		1.0	1.8	3.0	ns
t _{THL} (t _f)	Fall Time ⁽⁴⁾		1.0	1.8	3.0	ns
t _{PZH}	Enable Time (Z to Active High)	R _L = 50Ω, C _L = 5 pF, C _D = 0.5 pF See Figure 11 and Figure 12			8	ns
t _{PZL}	Enable Time (Z to Active Low)				8	ns
t _{PLZ}	Disable Time (Active Low to Z)				8	ns
t _{PHZ}	Disable Time (Active High to Z)				8	ns
t _{JIT}	Random Jitter, RJ ⁽⁴⁾	100 MHz Clock Pattern ⁽⁶⁾		2.5	5.5	psrms
f _{MAX}	Maximum Data Rate		200			Mbps
RECEIVER AC SPECIFICATION						
t _{PLH}	Propagation Delay Low to High	C _L = 15 pF See Figure 13, Figure 14 and Figure 15	2.0	4.7	7.5	ns
t _{PHL}	Propagation Delay High to Low		2.0	5.3	7.5	ns
t _{SKD1} (t _{sk(p)})	Pulse Skew t _{PLHD} - t _{PHLD} ⁽³⁾ ⁽⁴⁾			0.6	1.7	ns
t _{SKD3}	Part-to-Part Skew ⁽⁵⁾ ⁽⁴⁾				1.3	ns
t _{TLH} (t _r)	Rise Time ⁽⁴⁾		0.5	1.2	2.5	ns
t _{THL} (t _f)	Fall Time ⁽⁴⁾		0.5	1.2	2.5	ns
t _{PZH}	Enable Time (Z to Active High)	R _L = 500Ω, C _L = 15 pF See Figure 16 and Figure 17			10	ns
t _{PZL}	Enable Time (Z to Active Low)				10	ns
t _{PLZ}	Disable Time (Active Low to Z)				10	ns
t _{PHZ}	Disable Time (Active High to Z)				10	ns
f _{MAX}	Maximum Data Rate		200			Mbps

(1) All typicals are given for V_{CC} = 3.3V and T_A = 25°C.

(2) C_L includes fixture capacitance and C_D includes probe capacitance.

(3) t_{SKD1}, |t_{PLHD} - t_{PHLD}|, is the magnitude difference in differential propagation delay time between the positive going edge and the negative going edge of the same channel.

(4) Not production tested. Specified by a statistical analysis on a sample basis at the time of characterization.

(5) t_{SKD3}, Part-to-Part Skew, is defined as the difference between the minimum and maximum specified differential propagation delays. This specification applies to devices at the same V_{CC} and within 5°C of each other within the operating temperature range.

(6) Stimulus and fixture Jitter has been subtracted.

Test Circuits and Waveforms

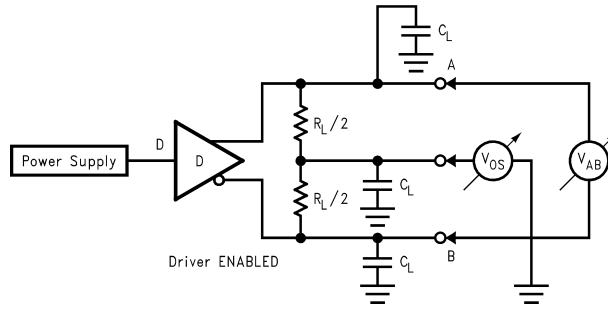

Figure 4. Differential Driver Test Circuit

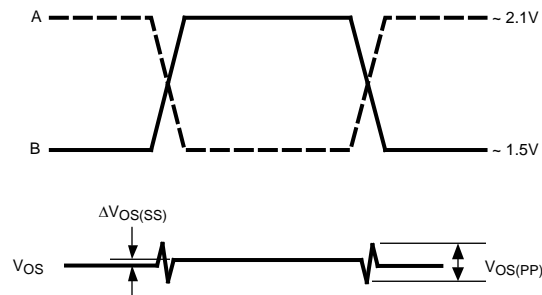

Figure 5. Differential Driver Waveforms

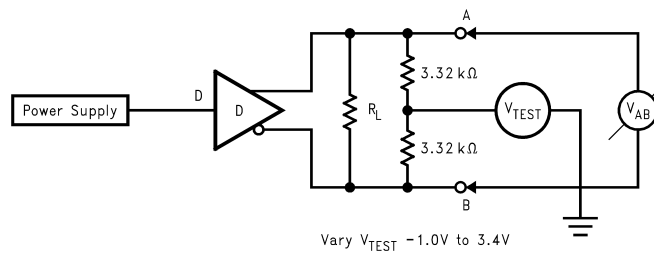

Figure 6. Differential Driver Full Load Test Circuit

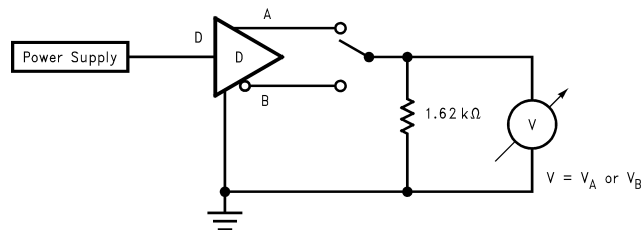

Figure 7. Differential Driver DC Open Test Circuit

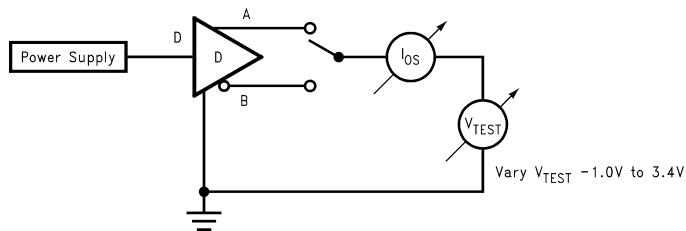

Figure 8. Differential Driver Short-Circuit Test Circuit

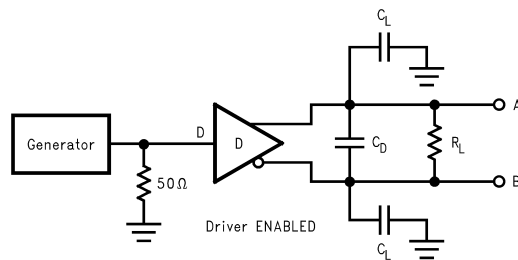

Figure 9. Driver Propagation Delay and Transition Time Test Circuit

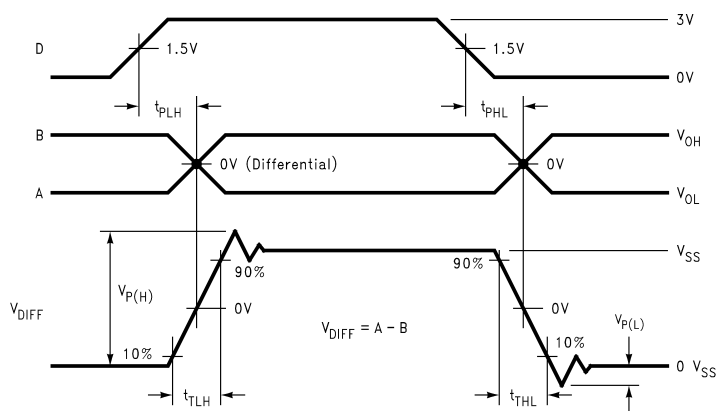

Figure 10. Driver Propagation Delays and Transition Time Waveforms

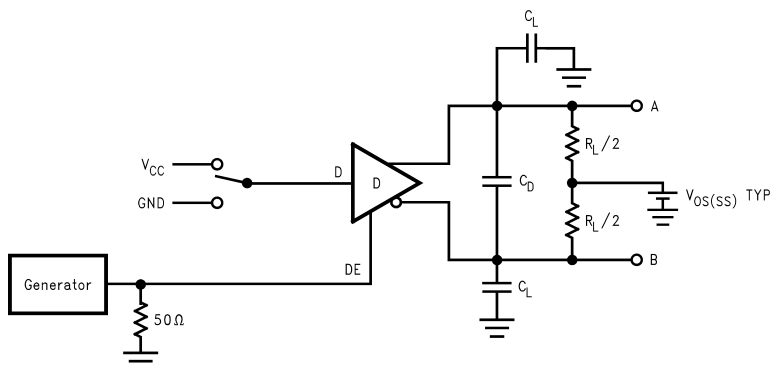

Figure 11. Driver TRI-STATE Delay Test Circuit

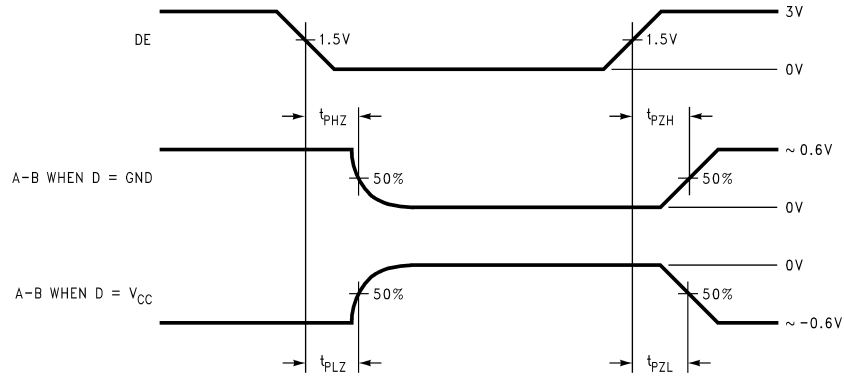

Figure 12. Driver TRI-STATE Delay Waveforms

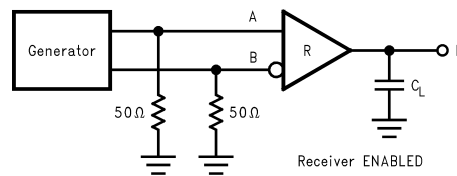

Figure 13. Receiver Propagation Delay and Transition Time Test Circuit

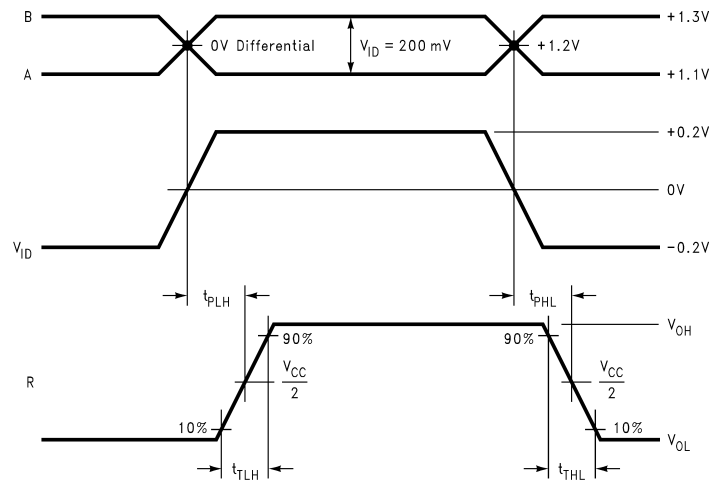

Figure 14. Type 1 Receiver Propagation Delay and Transition Time Waveforms

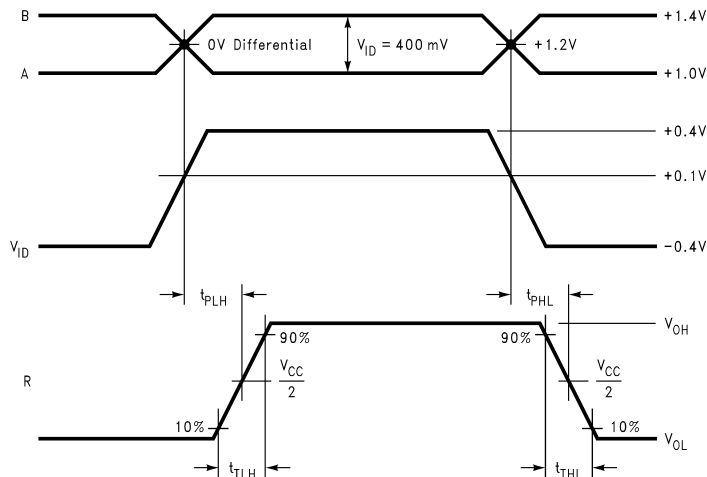

Figure 15. Type 2 Receiver Propagation Delay and Transition Time Waveforms

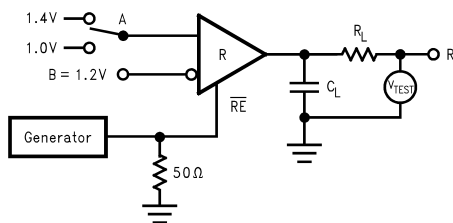

Figure 16. Receiver TRI-STATE Delay Test Circuit

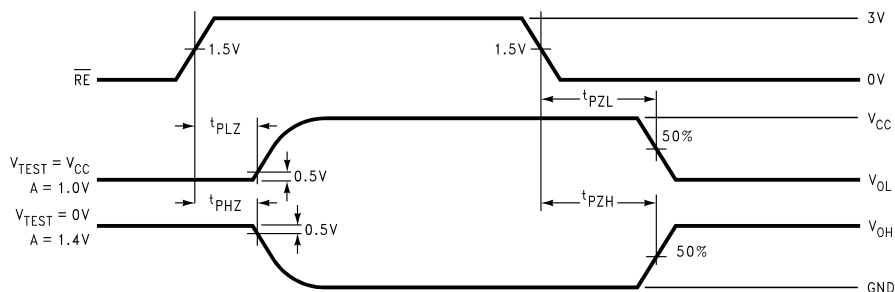

Figure 17. Receiver TRI-STATE Delay Waveforms

FUNCTION TABLES

Table 1. DS91D176/DS91C176 Transmitting⁽¹⁾

Inputs			Outputs	
RE	DE	D	B	A
X	2.0V	2.0V	L	H
X	2.0V	0.8V	H	L
X	0.8V	X	Z	Z

(1) X — Don't care condition
Z — High impedance state

Table 2. DS91D176 Receiving⁽¹⁾

Inputs			Output
\overline{RE}	DE	A – B	R
0.8V	0.8V	$\geq +0.05V$	H
0.8V	0.8V	$\leq -0.05V$	L
0.8V	0.8V	0V	X
2.0V	0.8V	X	Z

- (1) X — Don't care condition
Z — High impedance state

Table 3. DS91C176 Receiving⁽¹⁾

Inputs			Output
\overline{RE}	DE	A – B	R
0.8V	0.8V	$\geq +0.15V$	H
0.8V	0.8V	$\leq +0.05V$	L
0.8V	0.8V	0V	L
2.0V	0.8V	X	Z

- (1) X — Don't care condition
Z — High impedance state

Table 4. DS91D176 Receiver Input Threshold Test Voltages⁽¹⁾

Applied Voltages		Resulting Differential Input Voltage	Resulting Common-Mode Input Voltage	Receiver Output
V_{IA}	V_{IB}	V_{ID}	V_{IC}	R
2.400V	0.000V	2.400V	1.200V	H
0.000V	2.400V	-2.400V	1.200V	L
3.800V	3.750V	0.050V	3.775V	H
3.750V	3.800V	-0.050V	3.775V	L
-1.400V	-1.350V	-0.050V	-1.375V	H
-1.350V	-1.400V	0.050V	-1.375V	L

- (1) H — High Level
L — Low Level
Output state assumes that the receiver is enabled ($\overline{RE} = L$)

Table 5. DS91C176 Receiver Input Threshold Test Voltages⁽¹⁾

Applied Voltages		Resulting Differential Input Voltage	Resulting Common-Mode Input Voltage	Receiver Output
V_{IA}	V_{IB}	V_{ID}	V_{IC}	R
2.400V	0.000V	2.400V	1.200V	H
0.000V	2.400V	-2.400V	1.200V	L
3.800V	3.650V	0.150V	3.725V	H
3.800V	3.750V	0.050V	3.775V	L
-1.250V	-1.400V	0.150V	-1.325V	H
-1.350V	-1.400V	0.050V	-1.375V	L

- (1) H — High Level
L — Low Level
Output state assumes that the receiver is enabled ($\overline{RE} = L$)

PIN DESCRIPTIONS

Pin No.	Name	Description
1	R	Receiver output pin
2	\overline{RE}	Receiver enable pin: When \overline{RE} is high, the receiver is disabled. When \overline{RE} is low or open, the receiver is enabled.
3	DE	Driver enable pin: When DE is low, the driver is disabled. When DE is high, the driver is enabled.
4	D	Driver input pin
5	GND	Ground pin
6	A	Non-inverting driver output pin/Non-inverting receiver input pin
7	B	Inverting driver output pin/Inverting receiver input pin
8	V_{CC}	Power supply pin, +3.3V \pm 0.3V

Typical Performance Characteristics – DS91D176/DS91C176

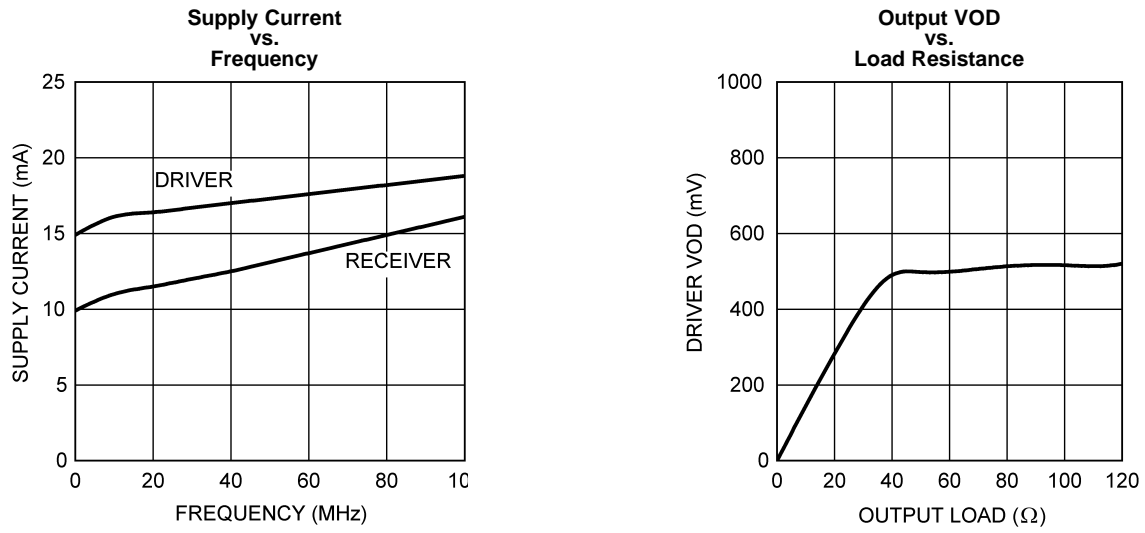

Supply Current measured using a clock pattern with driver terminated to 50ohms . $V_{CC} = 3.3V$, $T_A = +25^{\circ}C$

Figure 18.

Figure 19.

REVISION HISTORY

Changes from Revision K (April 2013) to Revision L	Page
<hr/> <ul style="list-style-type: none">• Changed layout of National Data Sheet to TI format	<hr/> 12

PACKAGING INFORMATION

Orderable Device	Status (1)	Package Type	Package Drawing	Pins	Package Qty	Eco Plan (2)	Lead finish/ Ball material (6)	MSL Peak Temp (3)	Op Temp (°C)	Device Marking (4/5)	Samples
DS91C176TMA	LIFEBUY	SOIC	D	8	95	Non-RoHS & Green	Call TI	Level-1-235C-UNLIM	-40 to 85	DS91C 176MA	
DS91C176TMA/NOPB	ACTIVE	SOIC	D	8	95	RoHS & Green	SN	Level-1-260C-UNLIM	-40 to 85	DS91C 176MA	Samples
DS91C176TMAX/NOPB	ACTIVE	SOIC	D	8	2500	RoHS & Green	SN	Level-1-260C-UNLIM	-40 to 85	DS91C 176MA	Samples
DS91D176TMA/NOPB	ACTIVE	SOIC	D	8	95	RoHS & Green	SN	Level-1-260C-UNLIM	-40 to 85	DS91D 176MA	Samples
DS91D176TMAX/NOPB	ACTIVE	SOIC	D	8	2500	RoHS & Green	SN	Level-1-260C-UNLIM	-40 to 85	DS91D 176MA	Samples

(1) The marketing status values are defined as follows:

ACTIVE: Product device recommended for new designs.

LIFEBUY: TI has announced that the device will be discontinued, and a lifetime-buy period is in effect.

NRND: Not recommended for new designs. Device is in production to support existing customers, but TI does not recommend using this part in a new design.

PREVIEW: Device has been announced but is not in production. Samples may or may not be available.

OBSELETE: TI has discontinued the production of the device.

(2) **RoHS:** TI defines "RoHS" to mean semiconductor products that are compliant with the current EU RoHS requirements for all 10 RoHS substances, including the requirement that RoHS substance do not exceed 0.1% by weight in homogeneous materials. Where designed to be soldered at high temperatures, "RoHS" products are suitable for use in specified lead-free processes. TI may reference these types of products as "Pb-Free".

RoHS Exempt: TI defines "RoHS Exempt" to mean products that contain lead but are compliant with EU RoHS pursuant to a specific EU RoHS exemption.

Green: TI defines "Green" to mean the content of Chlorine (Cl) and Bromine (Br) based flame retardants meet JS709B low halogen requirements of <=1000ppm threshold. Antimony trioxide based flame retardants must also meet the <=1000ppm threshold requirement.

(3) MSL, Peak Temp. - The Moisture Sensitivity Level rating according to the JEDEC industry standard classifications, and peak solder temperature.

(4) There may be additional marking, which relates to the logo, the lot trace code information, or the environmental category on the device.

(5) Multiple Device Markings will be inside parentheses. Only one Device Marking contained in parentheses and separated by a "~" will appear on a device. If a line is indented then it is a continuation of the previous line and the two combined represent the entire Device Marking for that device.

(6) Lead finish/Ball material - Orderable Devices may have multiple material finish options. Finish options are separated by a vertical ruled line. Lead finish/Ball material values may wrap to two lines if the finish value exceeds the maximum column width.

Important Information and Disclaimer: The information provided on this page represents TI's knowledge and belief as of the date that it is provided. TI bases its knowledge and belief on information provided by third parties, and makes no representation or warranty as to the accuracy of such information. Efforts are underway to better integrate information from third parties. TI has taken and continues to take reasonable steps to provide representative and accurate information but may not have conducted destructive testing or chemical analysis on incoming materials and chemicals. TI and TI suppliers consider certain information to be proprietary, and thus CAS numbers and other limited information may not be available for release.

In no event shall TI's liability arising out of such information exceed the total purchase price of the TI part(s) at issue in this document sold by TI to Customer on an annual basis.

TAPE AND REEL INFORMATION

QUADRANT ASSIGNMENTS FOR PIN 1 ORIENTATION IN TAPE

*All dimensions are nominal

Device	Package Type	Package Drawing	Pins	SPQ	Reel Diameter (mm)	Reel Width W1 (mm)	A0 (mm)	B0 (mm)	K0 (mm)	P1 (mm)	W (mm)	Pin1 Quadrant
DS91C176TMAX/NOPB	SOIC	D	8	2500	330.0	12.4	6.5	5.4	2.0	8.0	12.0	Q1
DS91D176TMAX/NOPB	SOIC	D	8	2500	330.0	12.4	6.5	5.4	2.0	8.0	12.0	Q1

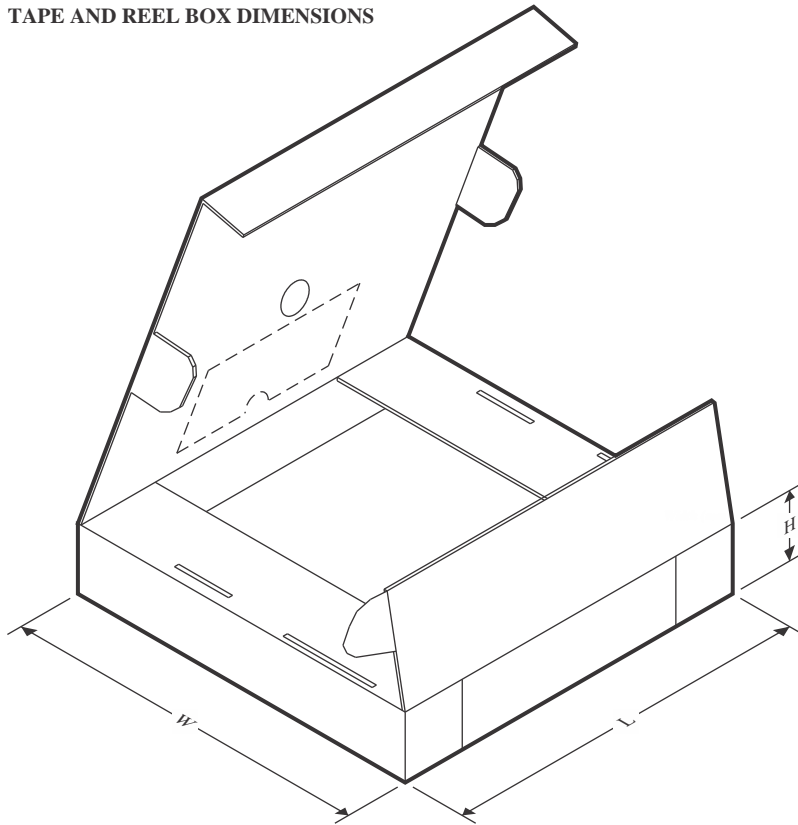
TAPE AND REEL BOX DIMENSIONS

*All dimensions are nominal

Device	Package Type	Package Drawing	Pins	SPQ	Length (mm)	Width (mm)	Height (mm)
DS91C176TMAX/NOPB	SOIC	D	8	2500	367.0	367.0	35.0
DS91D176TMAX/NOPB	SOIC	D	8	2500	367.0	367.0	35.0

TUBE

*All dimensions are nominal

Device	Package Name	Package Type	Pins	SPQ	L (mm)	W (mm)	T (μm)	B (mm)
DS91C176TMA	D	SOIC	8	95	495	8	4064	3.05
DS91C176TMA	D	SOIC	8	95	495	8	4064	3.05
DS91C176TMA/NOPB	D	SOIC	8	95	495	8	4064	3.05
DS91D176TMA/NOPB	D	SOIC	8	95	495	8	4064	3.05



D0008A

PACKAGE OUTLINE

SOIC - 1.75 mm max height

SMALL OUTLINE INTEGRATED CIRCUIT



4214825/C 02/2019

NOTES:

- Linear dimensions are in inches [millimeters]. Dimensions in parenthesis are for reference only. Controlling dimensions are in inches. Dimensioning and tolerancing per ASME Y14.5M.
- This drawing is subject to change without notice.
- This dimension does not include mold flash, protrusions, or gate burrs. Mold flash, protrusions, or gate burrs shall not exceed .006 [0.15] per side.
- This dimension does not include interlead flash.
- Reference JEDEC registration MS-012, variation AA.

EXAMPLE BOARD LAYOUT

D0008A

SOIC - 1.75 mm max height

SMALL OUTLINE INTEGRATED CIRCUIT

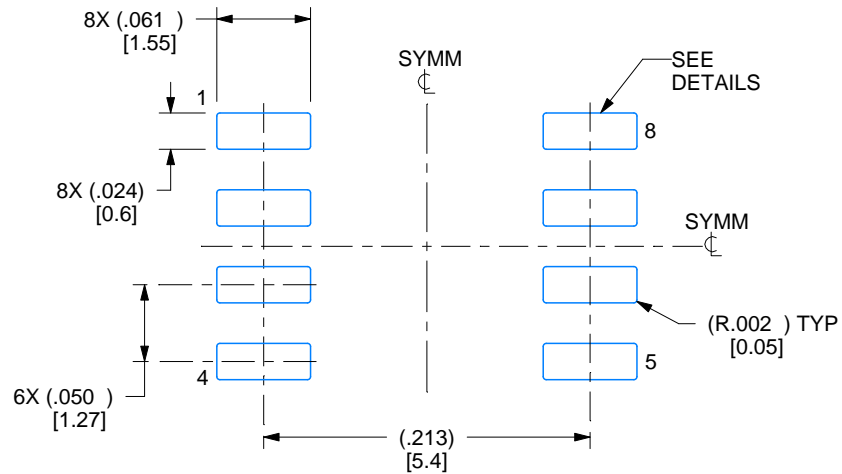

LAND PATTERN EXAMPLE
EXPOSED METAL SHOWN
SCALE:8X

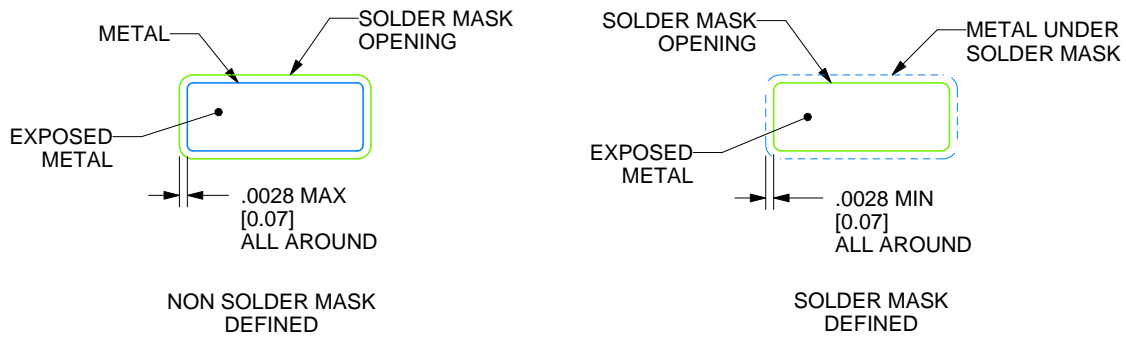

SOLDER MASK DETAILS

4214825/C 02/2019

NOTES: (continued)

- 6. Publication IPC-7351 may have alternate designs.
- 7. Solder mask tolerances between and around signal pads can vary based on board fabrication site.

EXAMPLE STENCIL DESIGN

D0008A

SOIC - 1.75 mm max height

SMALL OUTLINE INTEGRATED CIRCUIT



SOLDER PASTE EXAMPLE
BASED ON .005 INCH [0.125 MM] THICK STENCIL
SCALE:8X

4214825/C 02/2019

NOTES: (continued)

8. Laser cutting apertures with trapezoidal walls and rounded corners may offer better paste release. IPC-7525 may have alternate design recommendations.
9. Board assembly site may have different recommendations for stencil design.

IMPORTANT NOTICE AND DISCLAIMER

TI PROVIDES TECHNICAL AND RELIABILITY DATA (INCLUDING DATA SHEETS), DESIGN RESOURCES (INCLUDING REFERENCE DESIGNS), APPLICATION OR OTHER DESIGN ADVICE, WEB TOOLS, SAFETY INFORMATION, AND OTHER RESOURCES "AS IS" AND WITH ALL FAULTS, AND DISCLAIMS ALL WARRANTIES, EXPRESS AND IMPLIED, INCLUDING WITHOUT LIMITATION ANY IMPLIED WARRANTIES OF MERCHANTABILITY, FITNESS FOR A PARTICULAR PURPOSE OR NON-INFRINGEMENT OF THIRD PARTY INTELLECTUAL PROPERTY RIGHTS.

These resources are intended for skilled developers designing with TI products. You are solely responsible for (1) selecting the appropriate TI products for your application, (2) designing, validating and testing your application, and (3) ensuring your application meets applicable standards, and any other safety, security, regulatory or other requirements.

These resources are subject to change without notice. TI grants you permission to use these resources only for development of an application that uses the TI products described in the resource. Other reproduction and display of these resources is prohibited. No license is granted to any other TI intellectual property right or to any third party intellectual property right. TI disclaims responsibility for, and you will fully indemnify TI and its representatives against, any claims, damages, costs, losses, and liabilities arising out of your use of these resources.

TI's products are provided subject to [TI's Terms of Sale](#) or other applicable terms available either on [ti.com](https://www.ti.com) or provided in conjunction with such TI products. TI's provision of these resources does not expand or otherwise alter TI's applicable warranties or warranty disclaimers for TI products.

TI objects to and rejects any additional or different terms you may have proposed.

Mailing Address: Texas Instruments, Post Office Box 655303, Dallas, Texas 75265
Copyright © 2024, Texas Instruments Incorporated

Looking for pricing, stock, or lifecycle information?

Click below to explore more details on WIN SOURCE:

 [View DS91C176TMA](#) on WIN SOURCE

 [Texas Instruments](#) Information

Optimize Your Supply Chain with WIN SOURCE Solutions

-  Global Sourcing Solution
-  Obsolete Management
-  Cost Control Management
-  Shortage Management
-  Alternative Solution
-  Excess Inventory Management