

DS90URxxx-Q1 5-MHz to 43-MHz DC-Balanced 24-Bit FPD-Link II Serializer and Deserializer Chipset

1 Features

- Supports Displays With 18-Bit Color Depth
- 5-MHz to 43-MHz Pixel Clock
- Automotive-Grade Product AEC-Q100 Grade 2 Qualified
- 24:1 Interface Compression
- Embedded Clock With DC Balancing Supports AC-Coupled Data Transmission
- Capable to Drive up to 10 Meters Shielded Twisted-Pair Cable
- No Reference Clock Required (Deserializer)
- Meets ISO 10605 ESD – Greater than 8 kV HBM ESD Structure
- Hot Plug Support
- EMI Reduction – Serializer Accepts Spread Spectrum Input; Data Randomization and Shuffling on Serial Link; Deserializer Provides Adjustable PTO (Progressive Turnon) LVCMOS Outputs
- @Speed BIST (Built-In Self-Test) to Validate LVDS Transmission Path
- Individual Power-Down Controls for Both Transmitter and Receiver
- Power Supply Range 3.3 V ±10%
- 48-Pin TQFP Package for Transmitter and 64-Pin TQFP Package for Receiver
- Temperature Range: –40°C to 105°C
- Backward-Compatible Mode With DS90C241/DS90C124

2 Applications

- Automotive Central Information Displays
- Automotive Instrument Cluster Displays
- Automotive Heads-Up Displays
- Remote Camera-Based Driver Assistance Systems

3 Description

The DS90URxxx-Q1 chipset translates a 24-bit parallel bus into a fully transparent data/control FPD-Link II LVDS serial stream with embedded clock information. This chipset is ideally suited for driving graphical data to displays requiring 18-bit color depth: RGB666 + HS, VS, DE + three additional general-purpose data channels. This single serial stream simplifies transferring a 24-bit bus over PCB traces and cable by eliminating the skew problems between parallel data and clock paths. The device saves system cost by narrowing data paths that in turn reduce PCB layers, cable width, and connector size and pins.

The DS90URxxx-Q1 incorporates FPD-Link II LVDS signaling on the high-speed I/O. FPD-Link II LVDS provides a low-power and low-noise environment for reliably transferring data over a serial transmission path. By optimizing the Serializer output edge rate for the operating frequency range, EMI is further reduced.

Device Information⁽¹⁾

PART NUMBER	PACKAGE	BODY SIZE (NOM)
DS90UR124-Q1	TQFP (64)	10.00 mm x 10.00 mm
DS90UR241-Q1	TQFP (48)	7.00 mm x 7.00 mm

(1) For all available packages, see the orderable addendum at the end of the data sheet.

Applications Diagram

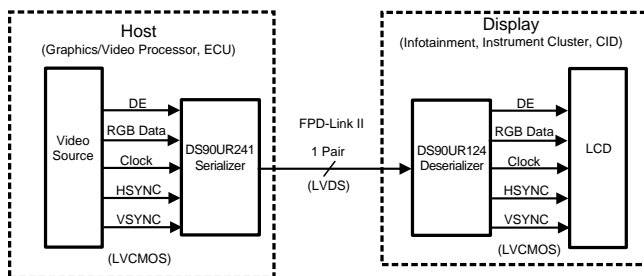

Block Diagram

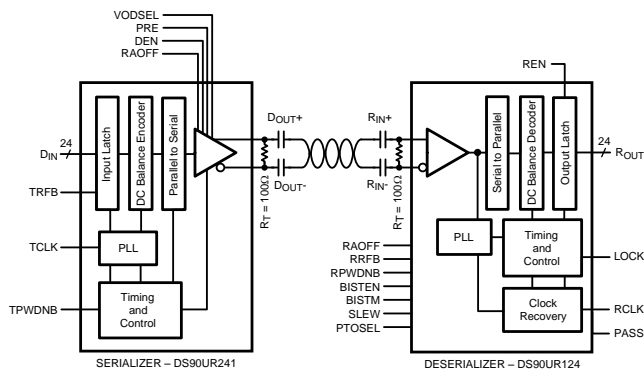

Table of Contents

1 Features 1 2 Applications 1 3 Description 1 4 Revision History 2 5 Description (continued) 3 6 Pin Configuration and Functions 3 7 Specifications 7 7.1 Absolute Maximum Ratings 7 7.2 ESD Ratings 7 7.3 Recommended Operating Conditions 7 7.4 Thermal Information 8 7.5 Electrical Characteristics 8 7.6 Serializer Input Timing Requirements for TCLK 10 7.7 Serializer Switching Characteristics 10 7.8 Deserializer Switching Characteristics 10 7.9 Typical Characteristics 17 8 Detailed Description 18 8.1 Overview 18	8.2 Functional Block Diagram 18 8.3 Feature Description 18 8.4 Device Functional Modes 23 9 Application and Implementation 24 9.1 Application Information 24 9.2 Typical Applications 25 10 Power Supply Recommendations 29 11 Layout 30 11.1 Layout Guidelines 30 11.2 Layout Examples 32 12 Device and Documentation Support 34 12.1 Device Support 34 12.2 Documentation Support 34 12.3 Related Links 34 12.4 Trademarks 34 12.5 Electrostatic Discharge Caution 34 12.6 Glossary 34 13 Mechanical, Packaging, and Orderable Information 34
---	---

4 Revision History

NOTE: Page numbers for previous revisions may differ from page numbers in the current version.

Changes from Revision N (March 2013) to Revision O	Page
<ul style="list-style-type: none"> • Added <i>ESD Ratings</i> table, <i>Feature Description</i> section, <i>Device Functional Modes</i>, <i>Application and Implementation</i> section, <i>Power Supply Recommendations</i> section, <i>Layout</i> section, <i>Device and Documentation Support</i> section, and <i>Mechanical, Packaging, and Orderable Information</i> section 1 	1

Changes from Revision M (March 2013) to Revision N	Page
<ul style="list-style-type: none"> • Changed layout of National Data Sheet to TI format 23 	23

5 Description (continued)

In addition, the device features pre-emphasis to boost signals over longer distances using lossy cables. Internal DC-balanced encoding and decoding is used to support AC-coupled interconnects. Using TI's proprietary random lock, the parallel data of the Serializer are randomized to the Deserializer without the need of REFCLK.

6 Pin Configuration and Functions

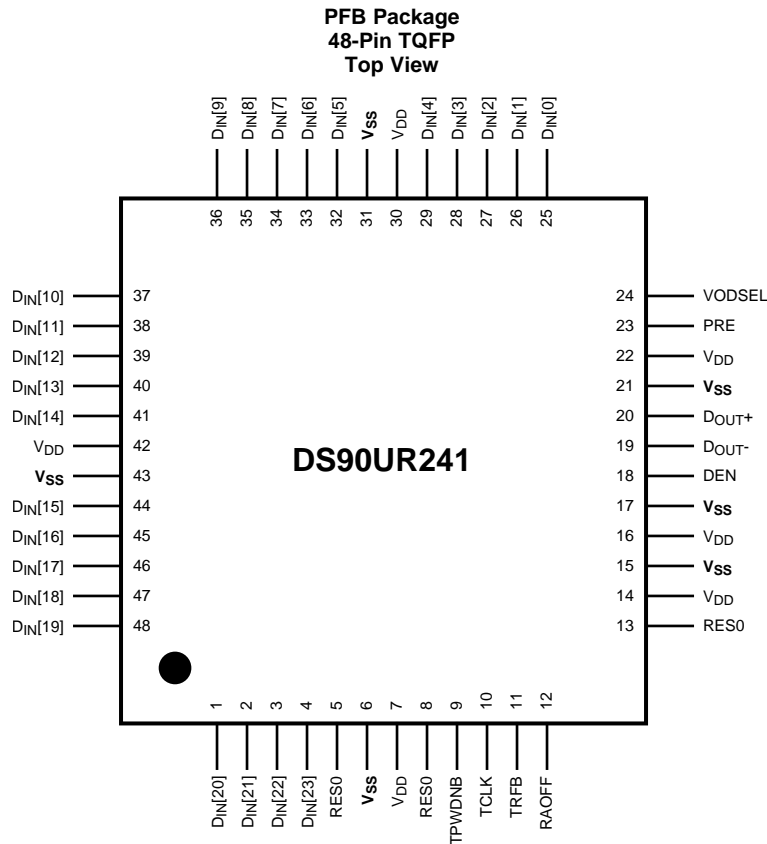

Pin Functions: PFB Package

PIN		I/O	DESCRIPTION
NO.	NAME		
LVC MOS PARALLEL INTERFACE PINS			
4-1, 48-44, 41-32, 29-25	D _{IN} [23:0]	LVC MOS_I	Transmitter Parallel Interface Data Input Pins. Tie LOW if unused; do not float.
10	TCLK	LVC MOS_I	Transmitter Parallel Interface Clock Input Pin. Strobe edge set by TRFB configuration pin.
CONTROL AND CONFIGURATION PINS			
18	DEN	LVC MOS_I	Transmitter Data Enable DEN = H; LVDS Driver Outputs are Enabled (ON). DEN = L; LVDS Driver Outputs are Disabled (OFF), Transmitter LVDS Driver D _{OUT} (+/-) Outputs are in Tri-state, PLL still operational and locked to TCLK.
23	PRE	LVC MOS_I	Pre-emphasis Level Select PRE = NC (No Connect); Pre-emphasis is Disabled (OFF). Pre-emphasis is active when input is tied to VSS through external resistor R _{PRE} . Resistor value determines pre-emphasis level. Recommended value R _{PRE} ≥ 6 kΩ; I _{max} = [48 / R _{PRE}], R _{PREmin} = 6 kΩ

Pin Functions: PFB Package (continued)

PIN		I/O	DESCRIPTION
NO.	NAME		
12	RAOFF	LVCMOS_I	Randomizer Control Input Pin RAOFF = H; Backwards compatible mode for use with DS90C124 Deserializer. RAOFF = L; Additional randomization ON (Default), Selects 2E7 LSFR setting. See Table 1 for more details.
5, 8, 13	RES0	LVCMOS_I	Reserved. This pin must be tied LOW.
9	TPWDNB	LVCMOS_I	Transmitter Power Down Bar TPWDNB = H; Transmitter is Enabled and ON TPWDNB = L; Transmitter is in power down mode (Sleep), LVDS Driver D _{OUT} (+/-) Outputs are in Tri-state stand-by mode, PLL is shutdown to minimize power consumption.
11	TRFB	LVCMOS_I	Transmitter Clock Edge Select Pin TRFB = H; Parallel Interface Data is strobed on the Rising Clock Edge. TRFB = L; Parallel Interface Data is strobed on the Falling Clock Edge
24	VODSEL	LVCMOS_I	VOD Level Select VODSEL = L; LVDS Driver Output is ±500 mV (R _L = 100 Ω) VODSEL = H; LVDS Driver Output is ±900 mV (R _L = 100 Ω) For normal applications, set this pin LOW. For long cable applications where a larger VOD is required, set this pin HIGH.
LVDS SERIAL INTERFACE PINS			
20	D _{OUT+}	LVDS_O	Transmitter LVDS True (+) Output. This output is intended to be loaded with a 100-Ω load to the D _{OUT+} pin. The interconnect should be AC coupled to this pin with a 100-nF capacitor.
19	D _{OUT-}	LVDS_O	Transmitter LVDS Inverted (-) Output This output is intended to be loaded with a 100-Ω load to the D _{OUT-} pin. The interconnect should be AC coupled to this pin with a 100-nF capacitor.
POWER / GROUND PINS			
22	VDD	VDD	Analog Voltage Supply, LVDS Output POWER
16	VDD	VDD	Analog Voltage Supply, VCO POWER
14	VDD	VDD	Analog Voltage Supply, PLL POWER
30	VDD	VDD	Digital Voltage Supply, Serializer POWER
7	VDD	VDD	Digital Voltage Supply, Serializer Logic POWER
42	VDD	VDD	Digital Voltage Supply, Serializer INPUT POWER
21	VSS	GND	Analog Ground, LVDS Output GROUND
17	VSS	GND	Analog Ground, VCO GROUND
15	VSS	GND	Analog Ground, PLL GROUND
31	VSS	GND	Digital Ground, Serializer GROUND
6	VSS	GND	Digital Ground, Serializer Logic GROUND
43	VSS	GND	Digital Ground, Serializer Input GROUND

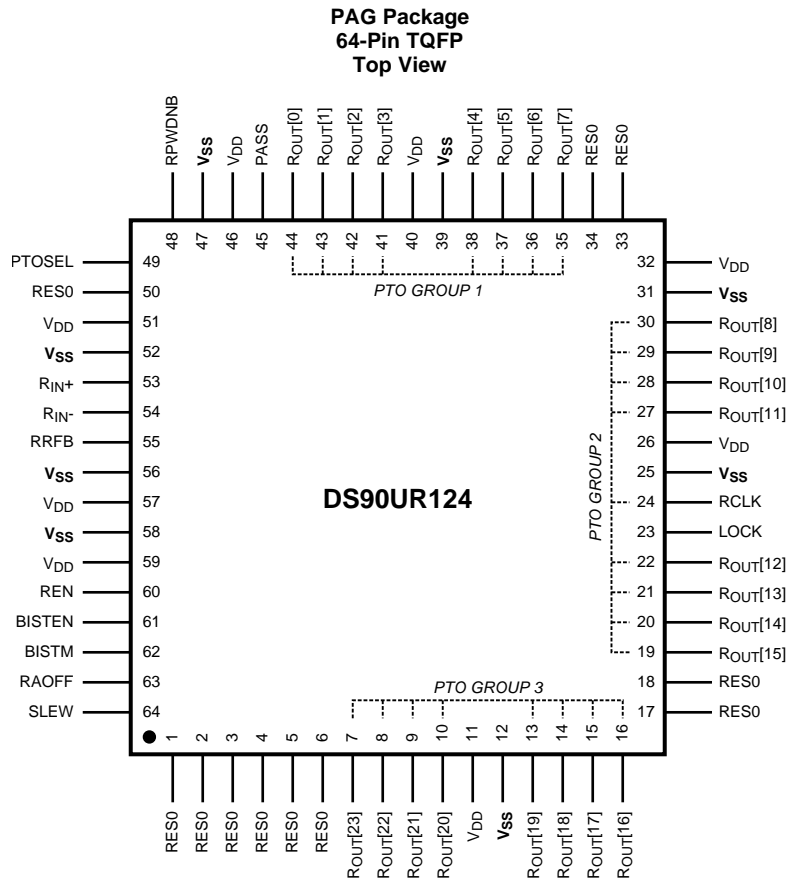

Pin Functions: PAG Package

PIN		I/O	DESCRIPTION
NO.	NAME		
LVC MOS PARALLEL INTERFACE PINS			
24	RCLK	LVC MOS_O	Parallel Interface Clock Output Pin. Strobe edge set by RRF B configuration pin.
35-38, 41-44	ROUT[7:0]	LVC MOS_O	Receiver Parallel Interface Data Outputs – Group 1
19-22, 27-30	ROUT[15:8]	LVC MOS_O	Receiver Parallel Interface Data Outputs – Group 2
7-10, 13-16	ROUT[23:16]	LVC MOS_O	Receiver Parallel Interface Data Outputs – Group 3
CONTROL AND CONFIGURATION PINS			
23	LOCK	LVC MOS_O	LOCK indicates the status of the receiver PLL LOCK = H; receiver PLL is locked LOCK = L; receiver PLL is unlocked, ROUT[23-0] and RCLK are at Tri-state.
49	PTOSEL	LVC MOS_I	Progressive Turn On Operation Selection PTO = H; ROUT[23:0] are grouped into three groups of eight, with each group switching about ±1 UI to ±2 UI apart relative to RCLK. (Figure 17) PTO = L; PTO Spread Mode, ROUT[23:0] outputs are spread ±1 UI to ±2 UI and RCLK spread ±1 UI. (Figure 18) See Applications Informations section for more details.
63	RAOFF	LVC MOS_I	Randomizer Control Input Pin (See Table 2 for more details.) RAOFF = H; Backwards compatible mode for use with DS90C241 Serializer. RAOFF = L; Additional randomization ON (Default), Selects 2E7 LSFR setting.
60	REN	LVC MOS_I	Receiver Data Enable REN = H; ROUT[23-0] and RCLK are Enabled (ON). REN = L; ROUT[23-0] and RCLK are Disabled (OFF), Receiver ROUT[23-0] and RCLK Outputs are in Tri-state, PLL still operational and locked to TCLK.

Pin Functions: PAG Package (continued)

PIN		I/O	DESCRIPTION
NO.	NAME		
50	RES0	LVC MOS_I	Reserved. This pin MUST be tied LOW.
1-6, 17, 18, 33, 34	RES0	NC	No Connection. Pins are not physically connected to the die. Recommendation is to leave pin open or tie it to LOW.
48	RPWDNB	LVC MOS_I	Receiver Power Down Bar RPWDNB = H; Receiver is Enabled and ON RPWDNB = L; Receiver is in power down mode (Sleep), R _{OUT} [23:0], RCLK, and LOCK are in Tri-state standby mode, PLL is shutdown to minimize power consumption.
55	RRFB	LVC MOS_I	Receiver Clock Edge Select Pin RRFB = H; R _{OUT} LVCMOS Outputs strobed on the Rising Clock Edge. RRFB = L; R _{OUT} LVCMOS Outputs strobed on the Falling Clock Edge.
64	SLEW	LVC MOS_I	LVCMOS Output Slew Rate Control SLEW = L; Low drive output at 2 mA (default) SLEW = H; High drive output at 4 mA
BIST MODE PINS (See Application and Implementation for more details.)			
61	BISTEN	LVC MOS_I	Control Pin for BIST Mode Enable BISTEN = L; Default at Low, Normal Mode. BISTEN = H; BIST mode active. When BISTEN = H and DS90UR241 DIN[23:0] = Low or Floating; device will go to BIST mode accordingly. Check PASS output pin for test status.
62	BISTM	LVC MOS_I	BIST Mode selection. Control pin for which Deserializer is set for BIST reporting mode. BISTM = L; Default at Low, Status of all R _{OUT} with respective bit error on cycle-by-cycle basis BISTM = H; Total accumulated bit error count provided on ROUT[7:0] (binary counter up to 255)
45	PASS	LVC MOS_O	Pass flag output for @Speed BIST Test operation. PASS = L; BIST failure PASS = H; LOCK = H before BIST can be enabled, then 1x10 ⁻⁹ error rate achieved across link.
LVDS SERIAL INTERFACE PINS			
53	R _{IN+}	LVDS_I	Receiver LVDS True (+) Input — This input is intended to be terminated with a 100Ω load to the R _{IN+} pin. The interconnect should be AC Coupled to this pin with a 100 nF capacitor.
54	R _{IN-}	LVDS_I	Receiver LVDS Inverted (-) Input — This input is intended to be terminated with a 100Ω load to the R _{IN-} pin. The interconnect should be AC Coupled to this pin with a 100 nF capacitor.
POWER / GROUND PINS			
51	VDD	VDD	Analog LVDS Voltage Supply, POWER
59	VDD	VDD	Analog Voltage Supply, PLL POWER
57	VDD	VDD	Analog Voltage supply, PLL VCO POWER
32	VDD	VDD	Digital Voltage Supply, LOGIC POWER
46	VDD	VDD	Digital Voltage Supply, LOGIC POWER
40	VDD	VDD	Digital Voltage Supply, LVCMOS Output POWER
26	VDD	VDD	Digital Voltage Supply, LVCMOS Output POWER
11	VDD	VDD	Digital Voltage Supply, LVCMOS Output POWER
52	VSS	GND	Analog LVDS GROUND
58	VSS	GND	Analog Ground, PLL GROUND
56	VSS	GND	Analog Ground, PLL VCO GROUND
31	VSS	GND	Digital Ground, Logic GROUND
47	VSS	GND	Digital Ground, LOGIC GROUND
39	VSS	GND	Digital Ground, LVCMOS Output GROUND
25	VSS	GND	Digital Ground, LVCMOS Output GROUND
12	VSS	GND	Digital Ground, LVCMOS Output GROUND

7 Specifications

7.1 Absolute Maximum Ratings

over operating free-air temperature range (unless otherwise noted) ⁽¹⁾

				MIN	MAX	UNIT
Supply Voltage (V_{DD})				-0.3	4	V
LVCMOS Input Voltage				-0.3	$V_{DD} + 0.3$	V
LVCMOS Output Voltage				-0.3	$V_{DD} + 0.3$	V
LVDS Receiver Input Voltage				-0.3	+3.9	V
LVDS Driver Output Voltage				-0.3	+3.9	V
LVDS Output Short Circuit Duration					10	ms
Junction Temperature					150	°C
Lead Temperature (Soldering, 4 seconds)					260	°C
Maximum Package Power Dissipation Capacity ⁽²⁾	Package Derating:	DS90UR241 – 48L TQFP	$R_{\theta JA}$	45.8 (4L); 75.4 (2L)		°C/W
			$R_{\theta JC}$	21.0		
		DS90UR124 – 64L TQFP	$R_{\theta JA}$	42.8 (4L); 67.2 (2L)		
			$R_{\theta JC}$	14.6		
Storage temperature, T_{stg}				-65	150	°C

(1) Stresses beyond those listed under *Absolute Maximum Ratings* may cause permanent damage to the device. These are stress ratings only, which do not imply functional operation of the device at these or any other conditions beyond those indicated under *Recommended Operating Conditions*. Exposure to absolute-maximum-rated conditions for extended periods may affect device reliability.

(2) $1/R_{\theta JA}$ °C/W above +25°C

7.2 ESD Ratings

				VALUE	UNIT	
DS90UR241-Q1 IN PFB PACKAGE						
$V_{(ESD)}$ Electrostatic discharge	Human body model (HBM), per AEC Q100-002 ⁽¹⁾	All pins		$\geq \pm 8000$	V	
			Charged device model (CDM), per AEC Q100-011	Corner pins (1, 12, 13, 24, 25, 36, 37, and 48)		± 12500
				Other pins		± 12500
			(ISO10605) ⁽²⁾	Contact Discharge (20, 19)		± 10000
				Air Discharge (20, 19)		± 30000
DS90UR124-Q1 IN PAG PACKAGE						
$V_{(ESD)}$ Electrostatic discharge	Human body model (HBM), per AEC Q100-002 ⁽¹⁾	All pins		$\geq \pm 8000$	V	
			Charged device model (CDM), per AEC Q100-011	Corner pins (1, 16, 17, 32, 33, 48, 49, and 64)		± 12500
				Other pins		± 12500
			(ISO10605) ⁽²⁾	Contact Discharge (R_{IN+} , R_{IN-})		± 10000
				Air Discharge (R_{IN+} , R_{IN-})		± 30000

(1) AEC Q100-002 indicates HBM stressing is done in accordance with the ANSI/ESDA/JEDEC JS-001 specification.

(2) $R_D = 2 \text{ k}\Omega$, $C_S = 330 \text{ pF}$

7.3 Recommended Operating Conditions

over operating free-air temperature range (unless otherwise noted)

	MIN	NOM	MAX	UNIT
Supply Voltage (V_{DD})	3.0	3.3	3.6	V
Operating Free Air Temperature (T_A)	-40	25	105	°C
Clock Rate	5		43	MHz
Supply Noise			± 100	mV _{P-P}

7.4 Thermal Information

THERMAL METRIC ⁽¹⁾		DS90UR124-Q1	DS90UR241-Q1	UNIT
		PAG [TQFP]	PFB [TQFP]	
		64 PINS	48 PINS	
R _{θJA}	Junction-to-ambient thermal resistance	58.1	64.3	°C/W
R _{θJC(top)}	Junction-to-case (top) thermal resistance	13.0	14.1	
R _{θJB}	Junction-to-board thermal resistance	30.4	30.2	
ψ _{JT}	Junction-to-top characterization parameter	0.3	0.4	
ψ _{JB}	Junction-to-board characterization parameter	30.0	29.8	

(1) For more information about traditional and new thermal metrics, see the *IC Package Thermal Metrics* application report, SPRA953.

7.5 Electrical Characteristics

over recommended operating supply and temperature ranges unless otherwise specified

PARAMETER	TEST CONDITIONS	PIN/FREQ.	MIN	TYP	MAX	UNIT	
LVCMOS DC SPECIFICATIONS							
V _{IH}	High-Level Input Voltage	Tx: D _{IN} [0:23], TCLK, TPWDNB, DEN, TRFB, RAOFF, VODSEL, RES0. Rx: RPWDNB, RRFB, REN, PTOSEL, BISTEN, BISTM, SLEW, RES0.	2		V _{DD}	V	
V _{IL}	Low-Level Input Voltage		GND		0.8	V	
V _{CL}	Input Clamp Voltage		I _{CL} = -18 mA	-0.8		-1.5	V
I _{IN}	Input Current	V _{IN} = 0 V or 3.6 V		-10	±2	10	μA
			Rx: RPWDNB	-20	±5	20	
V _{OH}	High-Level Output Voltage	I _{OH} = -2 mA, SLEW = L I _{OH} = -4 mA, SLEW = H	2.3	3	V _{DD}	V	
V _{OL}	Low-Level Output Voltage	I _{OL} = 2 mA, SLEW = L I _{OL} = 4 mA, SLEW = H	GND	0.33	0.5	V	
I _{OS}	Output Short Circuit Current	V _{OUT} = 0 V					-40
I _{OZ}	Tri-state Output Current	RPWDNB, REN = 0 V, V _{OUT} = 0 V or V _{DD}	Rx: R _{OUT} [0:23], RCLK, LOCK, PASS.	-30	±0.4	30	μA
LVDS DC SPECIFICATIONS							
V _{TH}	Differential Threshold High Voltage	V _{CM} = 1.8 V			50	mV	
V _{TL}	Differential Threshold Low Voltage		Rx: R _{IN+} , R _{IN-}	-50			mV
I _{IN}	Input Current		V _{IN} = 2.4 V, V _{DD} = 3.6 V		±100	±250	μA
		V _{IN} = 0 V, V _{DD} = 3.6 V		±100	±250		

Electrical Characteristics (continued)

over recommended operating supply and temperature ranges unless otherwise specified

PARAMETER		TEST CONDITIONS		PIN/FREQ.	MIN	TYP	MAX	UNIT
V_{OD}	Output Differential Voltage (D_{OUT+})–(D_{OUT-})	$R_L = 100 \Omega$, without pre-emphasis Figure 12	VODSEL = L	Tx: D_{OUT+} , D_{OUT-}	380	500	630	mV
			VODSEL = H		500	900	1100	
ΔV_{OD}	Output Differential Voltage Unbalance	$R_L = 100 \Omega$, without pre-emphasis	VODSEL = L		1	50	mV	
			VODSEL = H					
V_{OS}	Offset Voltage	$R_L = 100 \Omega$, without pre-emphasis	VODSEL = L		1	1.25	1.50	V
			VODSEL = H					
ΔV_{OS}	Offset Voltage Unbalance	$R_L = 100 \Omega$, without pre-emphasis	VODSEL = L		3	50	mV	
			VODSEL = H					
I_{OS}	Output Short Circuit Current	$D_{OUT} = 0 V$, $D_{IN} = H$, TPWDNB = 2.4 V	VODSEL = L		–2	–5	–8	mA
			VODSEL = H		–4.5	–7.9	–14	
I_{OZ}	Tri-state Output Current	TPWDNB = 0 V, $D_{OUT} = 0 V$ OR V_{DD}		–15	± 1	15	μA	
		TPWDNB = 2.4 V, DEN = 0 V $D_{OUT} = 0 V$ OR V_{DD}		–15	± 1	15		
		TPWDNB = 2.4 V, DEN = 2.4 V, $D_{OUT} = 0 V$ OR V_{DD} NO LOCK (NO TCLK)		–15	± 1	15		
SER/DES SUPPLY CURRENT (DVDD*, PVDD* AND AVDD* PINS) *DIGITAL, PLL, AND ANALOG VDDS								
I_{DDT}	Serializer Total Supply Current (includes load current)	$R_L = 100 \Omega$, PRE = OFF, RAOFF = H, VODSEL = L	$f = 43 \text{ MHz}$, checkerboard pattern Figure 3	60	85	mA		
			$R_L = 100 \Omega$, PRE = 12 k Ω , RAOFF = H, VODSEL = L	65	90			
			$R_L = 100 \Omega$, PRE = OFF, RAOFF = H, VODSEL = H	$f = 43 \text{ MHz}$, random pattern	66		90	
I_{DDTZ}	Serializer Supply Current Power-down	TPWDNB = 0V (All other LVCMOS Inputs = 0 V)			45	μA		
I_{DDR}	Deserializer Total Supply Current (includes load current)	$C_L = 4 \text{ pF}$, SLEW = H	$f = 43 \text{ MHz}$, checkerboard pattern LVCMOS Output Figure 4	85	105	mA		
			$f = 43 \text{ MHz}$, random pattern LVCMOS Output	80	100			
I_{DDRZ}	Deserializer Supply Current Power-down	RPWDNB = 0 V (All other LVCMOS Inputs = 0 V, $R_{IN+}/R_{IN-} = 0 V$)			50	μA		

7.6 Serializer Input Timing Requirements for TCLK

over recommended operating supply and temperature ranges unless otherwise specified

			MIN	NOM	MAX	UNIT
t _{TCP}	Transmit Clock Period	Figure 7	23.25	T	200	ns
t _{TCIH}	Transmit Clock High Time		0.3 T	0.5 T	0.7 T	ns
t _{TCIL}	Transmit Clock Low Time		0.3 T	0.5 T	0.7 T	ns
t _{CLKT}	TCLK Input Transition Time	Figure 6	2.5			ns
t _{JIT}	TCLK Input Jitter	f = 43 MHz			±100	ps
		f = 33 MHz			±130	

7.7 Serializer Switching Characteristics

over recommended operating supply and temperature ranges unless otherwise specified

PARAMETER	TEST CONDITIONS	MIN	TYP	MAX	UNIT
t _{LLHT}	LVDS Low-to-High Transition Time	R _L = 100 Ω, VODSEL = L, C _L = 10 pF to GND, Figure 5	245	550	ps
t _{LHLT}	LVDS High-to-Low Transition Time		264	550	ps
t _{DIS}	D _{IN} (0:23) Setup to TCLK	R _L = 100 Ω, C _L = 10 pF to GND Figure 7	4		ns
t _{DIH}	D _{IN} (0:23) Hold from TCLK		4		ns
t _{HZD}	D _{OUT} ± HIGH to Tri-state Delay	R _L = 100 Ω, C _L = 10 pF to GND Figure 8	10	15	ns
t _{LZD}	D _{OUT} ± LOW to Tri-state Delay		10	15	ns
t _{ZHD}	D _{OUT} ± Tri-state to HIGH Delay		75	150	ns
t _{ZLD}	D _{OUT} ± Tri-state to LOW Delay		75	150	ns
t _{PLD}	Serializer PLL Lock Time	R _L = 100 Ω		10	ms
t _{SD}	Serializer Delay	R _L = 100 Ω, PRE = OFF, RAOFF = L, TRFB = H, Figure 10	3.5T+2	3.5T+10	ns
		R _L = 100 Ω, PRE = OFF, RAOFF = L, TRFB = L, Figure 10	3.5T+2	3.5T+10	
TxOUT _E_O	TxOUT_Eye_Opening. TxOUT_E_O centered on (tBIT/2)	5 MHz–43 MHz, R _L = 100 Ω, C _L = 10 pF to GND, RANDOM pattern Figure 11	0.76	0.84	UI

7.8 Deserializer Switching Characteristics

over recommended operating supply and temperature ranges unless otherwise specified

PARAMETER	TEST CONDITIONS	PIN/FREQ.	MIN	TYP	MAX	UNIT	
t _{RCP}	Receiver out Clock Period	t _{RCP} = t _{TCP} , PTOSEL = H	RCLK Figure 17	23.25	T	200	ns
t _{RDC}	RCLK Duty Cycle	PTOSEL = H, SLEW = L		45%	50%	55%	
t _{CLH}	LVCMOS Low-to-High Transition Time	C _L = 4 pF (lumped load), SLEW = H	R _{OUT} [0:23], RCLK, LOCK	1.5	2.5	ns	
t _{CHL}	LVCMOS High-to-Low Transition Time			1.5	2.5	ns	
t _{CLH}	LVCMOS Low-to-High Transition Time	C _L = 4 pF (lumped load), SLEW = L	R _{OUT} [0:23], RCLK, LOCK	2.0	3.5	ns	
t _{CHL}	LVCMOS High-to-Low Transition Time			2.0	3.5	ns	
t _{ROS}	R _{OUT} (0:7) Setup Data to RCLK (Group 1)	PTOSEL = L, SLEW = H, Figure 18	R _{OUT} [0:7]	(0.35) × t _{RCP}	(0.5 × t _{RCP}) – 3 UI	ns	
t _{ROH}	R _{OUT} (0:7) Hold Data to RCLK (Group 1)			(0.35) × t _{RCP}	(0.5 × t _{RCP}) – 3 UI	ns	

Deserializer Switching Characteristics (continued)

over recommended operating supply and temperature ranges unless otherwise specified

PARAMETER	TEST CONDITIONS	PIN/FREQ.	MIN	TYP	MAX	UNIT	
t_{ROS}	R_{OUT} (8:15) Setup Data to RCLK (Group 2)	P _{TOSEL} = L, SLEW = H, Figure 18	R_{OUT} [8:15], LOCK	$(0.35) \times t_{RCP}$	$(0.5 \times t_{RCP}) - 3 \text{ UI}$	ns	
t_{ROH}	R_{OUT} (8:15) Hold Data to RCLK (Group 2)			$(0.35) \times t_{RCP}$	$(0.5 \times t_{RCP}) - 3 \text{ UI}$	ns	
t_{ROS}	R_{OUT} (16:23) Setup Data to RCLK (Group 3)		R_{OUT} [16:23]	$(0.35) \times t_{RCP}$	$(0.5 \times t_{RCP}) - 3 \text{ UI}$	ns	
t_{ROH}	R_{OUT} (16:23) Setup Data to RCLK (Group 3)			$(0.35) \times t_{RCP}$	$(0.5 \times t_{RCP}) - 3 \text{ UI}$	ns	
t_{ROS}	R_{OUT} (0:7) Setup Data to RCLK (Group 1)	P _{TOSEL} = H, SLEW = H, Figure 17	R_{OUT} [0:7]	$(0.35) \times t_{RCP}$	$(0.5 \times t_{RCP}) - 2 \text{ UI}$	ns	
t_{ROH}	R_{OUT} (0:7) Hold Data to RCLK (Group 1)			$(0.35) \times t_{RCP}$	$(0.5 \times t_{RCP}) + 2 \text{ UI}$	ns	
t_{ROS}	R_{OUT} (8:15) Setup Data to RCLK (Group 2)		R_{OUT} [8:15], LOCK	$(0.35) \times t_{RCP}$	$(0.5 \times t_{RCP}) - 1 \text{ UI}$	ns	
t_{ROH}	R_{OUT} (8:15) Hold Data to RCLK (Group 2)			$(0.35) \times t_{RCP}$	$(0.5 \times t_{RCP}) + 1 \text{ UI}$	ns	
t_{ROS}	R_{OUT} (16:23) Setup Data to RCLK (Group 3)	R_{OUT} [16:23]	$(0.35) \times t_{RCP}$	$(0.5 \times t_{RCP}) + 1 \text{ UI}$	ns		
t_{ROH}	R_{OUT} (16:23) Setup Data to RCLK (Group 3)		$(0.35) \times t_{RCP}$	$(0.5 \times t_{RCP}) - 1 \text{ UI}$	ns		
t_{HZR}	HIGH to Tri-state Delay	P _{TOSEL} = H, Figure 16	R_{OUT} [0:23], RCLK, LOCK		3	10	ns
t_{LZR}	LOW to Tri-state Delay				3	10	ns
t_{ZHR}	Tri-state to HIGH Delay				3	10	ns
t_{ZLR}	Tri-state to LOW Delay				3	10	ns
t_{DD}	Deserializer Delay	P _{TOSEL} = H, Figure 14	RCLK	$[5+(5/56)]T + 3.7$	$[5+(5/56)]T + 8$	ns	
t_{DSR}	Deserializer PLL Lock Time from Powerdown	See Figure 16	5 MHz		128k*T	ms	
			43 MHz		128k*T		
RxIN_T OL-L	Receiver INput TOLerance Left	See Figure 19	5 MHz–43 MHz		0.25	UI	
RxIN_T OL-R	Receiver INput TOLerance Right	See Figure 19	5 MHz–43 MHz		0.25	UI	

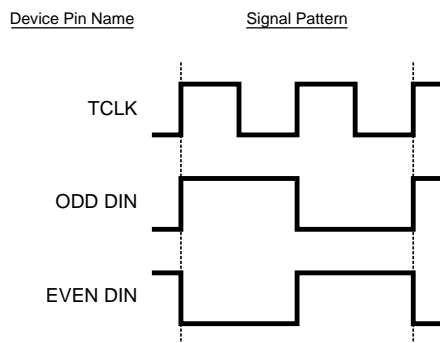

Figure 3. Serializer Input Checkerboard Pattern

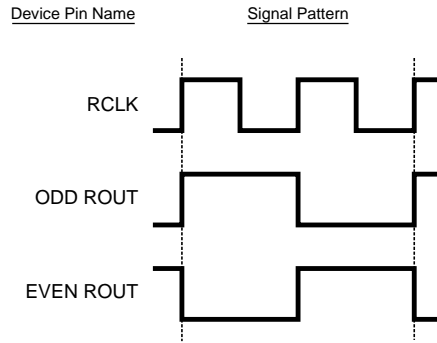

Figure 4. Deserializer Output Checkerboard Pattern

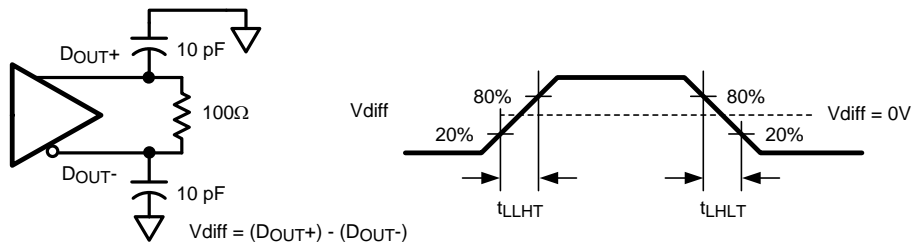

Figure 5. Serializer LVDS Output Load and Transition Times

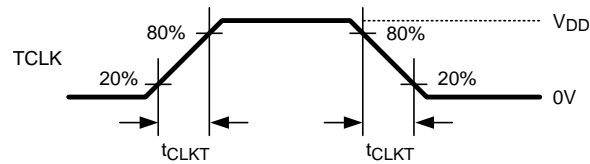

Figure 6. Serializer Input Clock Transition Times

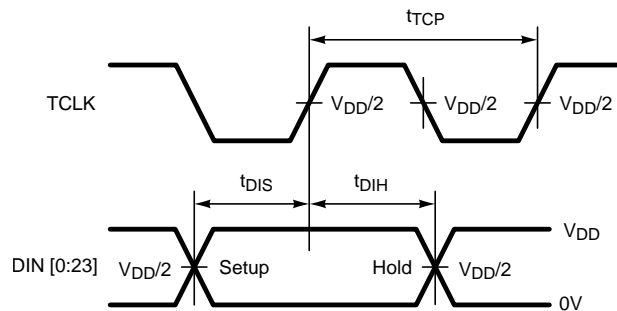

Figure 7. Serializer Setup and Hold Times

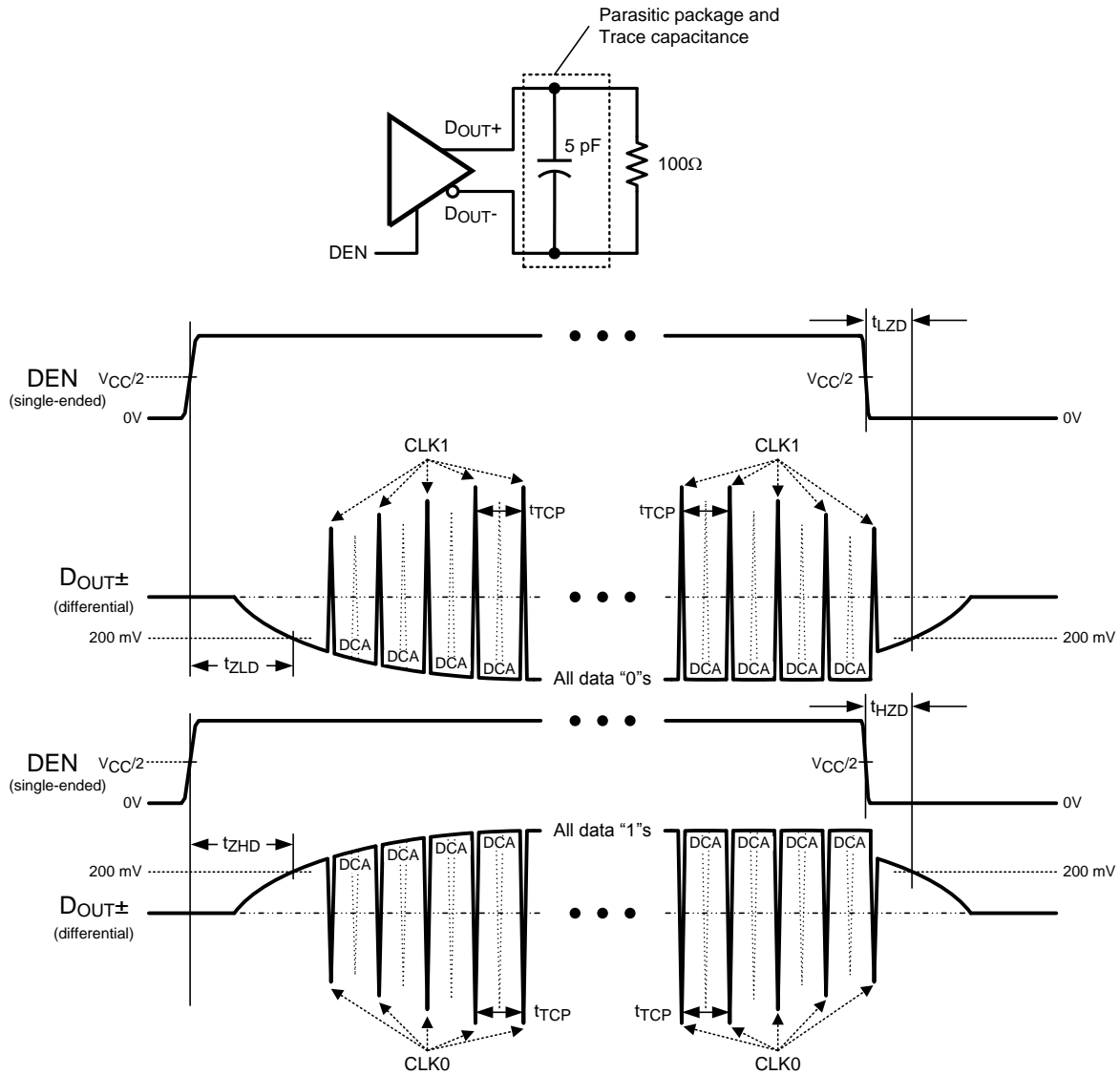

Figure 8. Serializer Tri-State Test Circuit and Delay

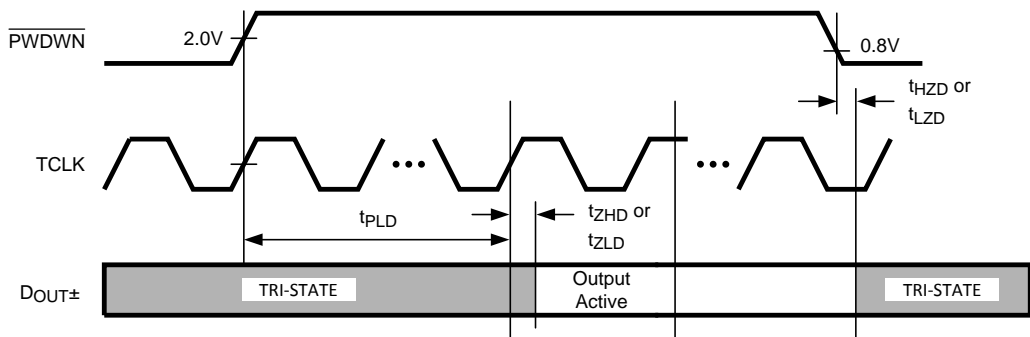

Figure 9. Serializer PLL Lock Time, and TPWDNB Tri-State Delays

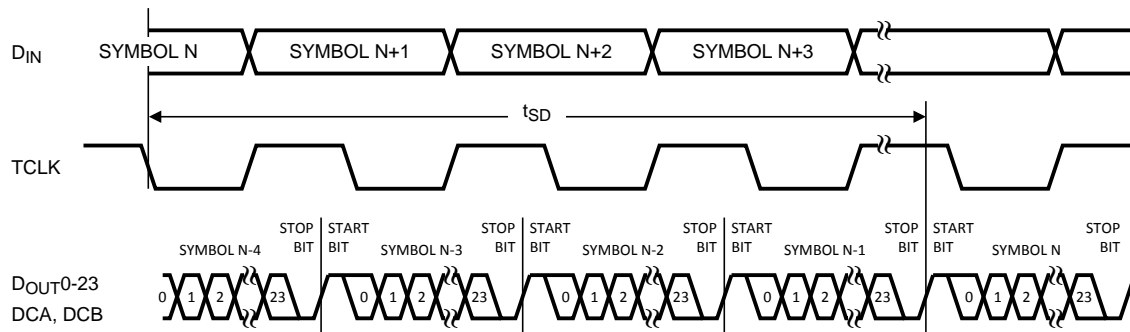

Figure 10. Serializer Delay

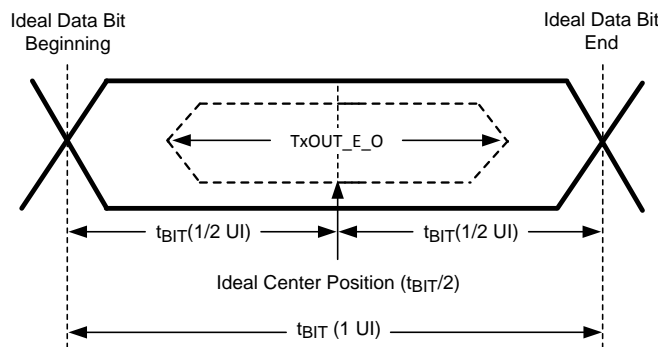
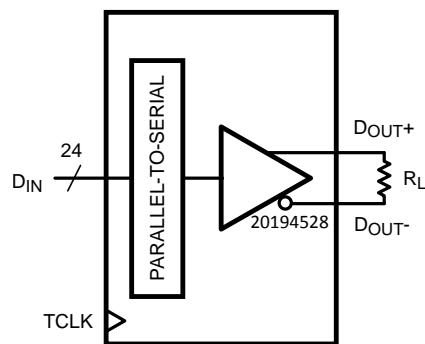

Figure 11. Transmitter Output Eye Opening (TxOUT_E_O)



$$VOD = (D_{OUT+}) - (D_{OUT-})$$

Differential output signal is shown as $(D_{OUT+}) - (D_{OUT-})$, device in Data Transfer mode.

Figure 12. Serializer V_{OD} Diagram

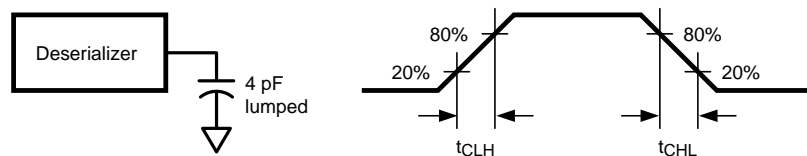

Figure 13. Deserializer LVCMOS Output Load and Transition Times

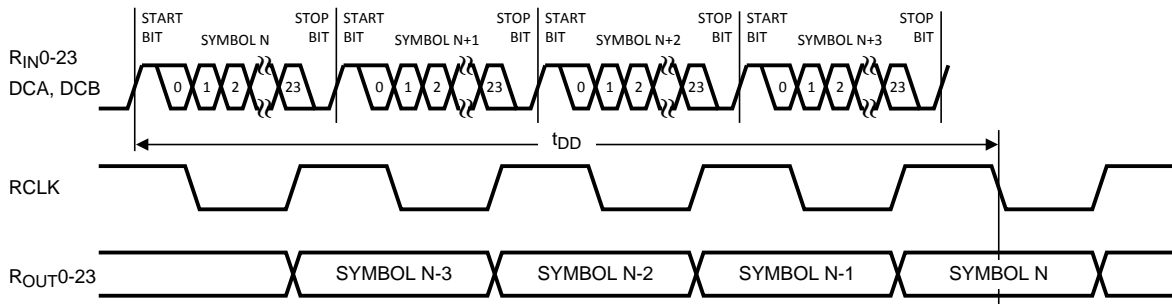
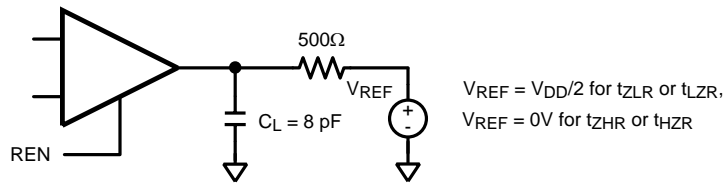

Figure 14. Deserializer Delay



NOTE:
 C_L includes instrumentation and fixture capacitance within 6 cm of $R_{OUT} [23:0]$.

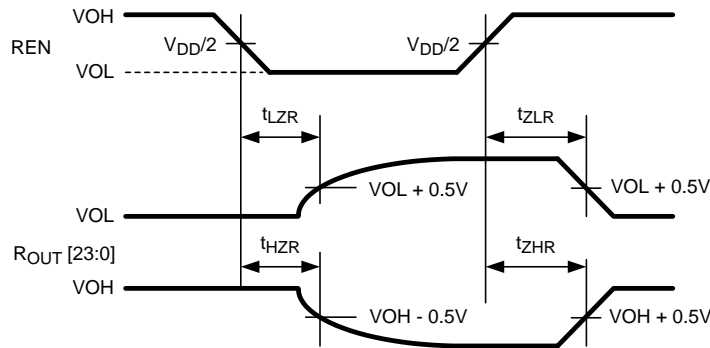

Figure 15. Deserializer Tri-State Test Circuit and Timing

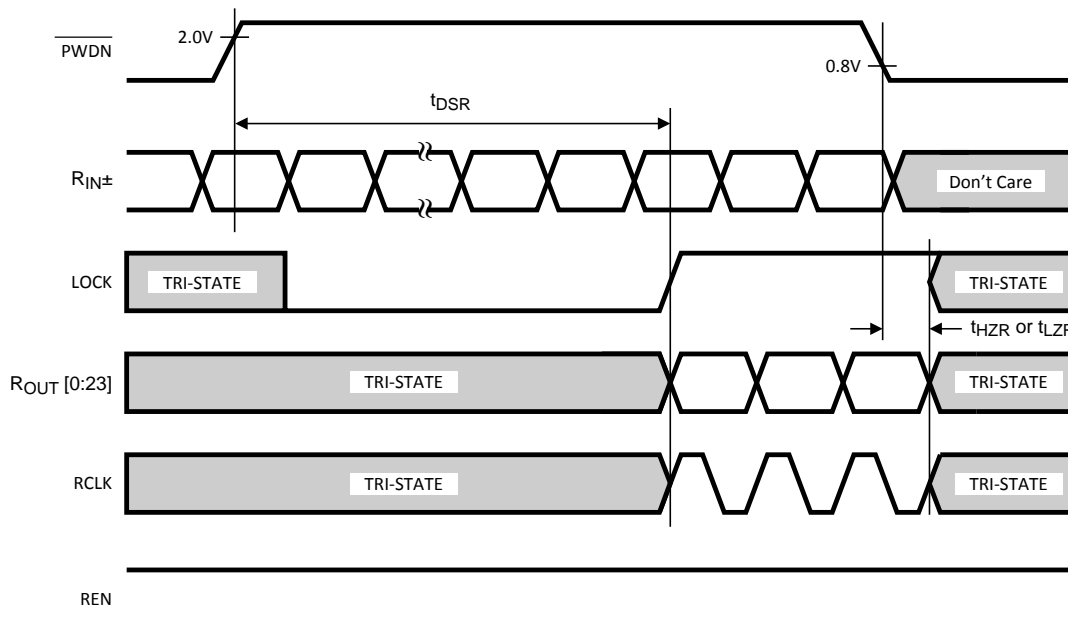

Figure 16. Deserializer PLL Lock Times and RPWDNB Tri-State Delay

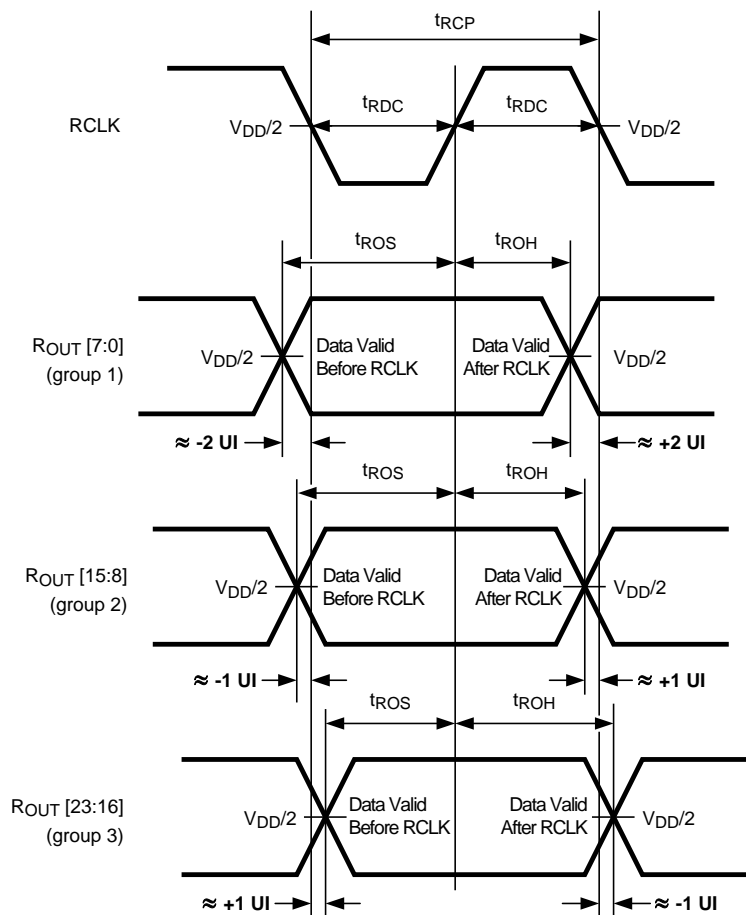
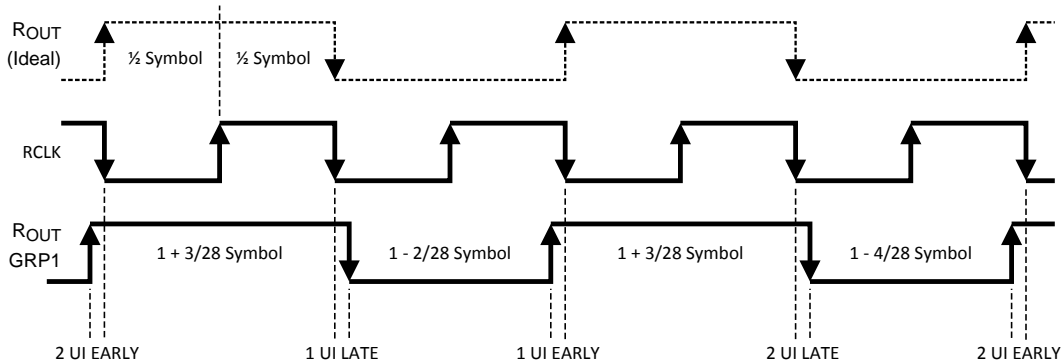
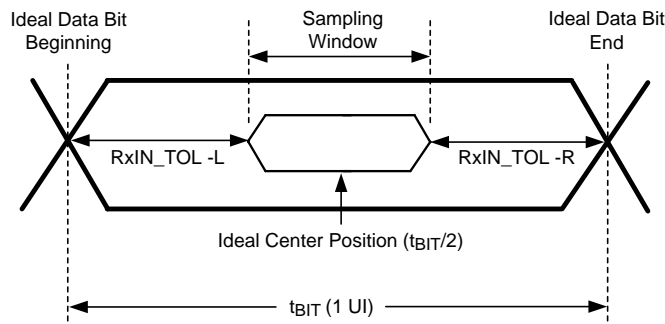

Figure 17. Deserializer Setup and Hold Times and PTO, PTOSEL = H



Group 1 will be latched internally by sequence of (early 2UI, late 1UI, early 1UI, late 2UI).
 Group 2 will be latched internally by sequence of (late 1UI, early 1UI, late 2UI, early 2UI).
 Group 3 will be latched internally by sequence of (early 1UI, late 2UI, early 2UI, late 1UI).

Figure 18. Deserializer Setup and Hold Times and PTO Spread, PTOSEL = L



RxIN_TOL_L is the ideal noise margin on the left of the figure, with respect to ideal.
 RxIN_TOL_R is the ideal noise margin on the right of the figure, with respect to ideal.

Figure 19. Receiver Input Tolerance (RxIN_TOL) and Sampling Window

7.9 Typical Characteristics

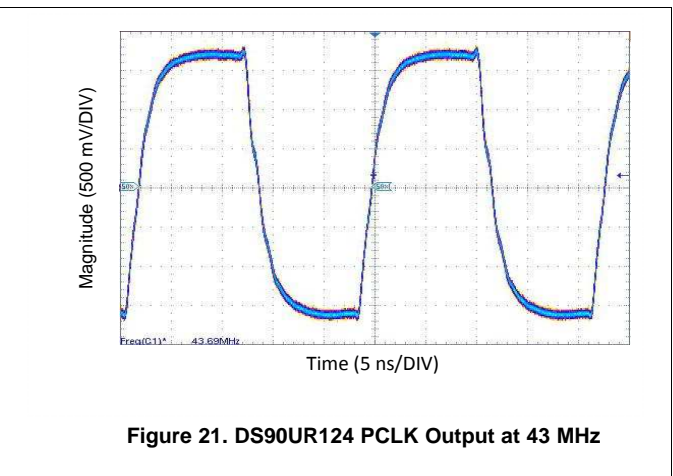
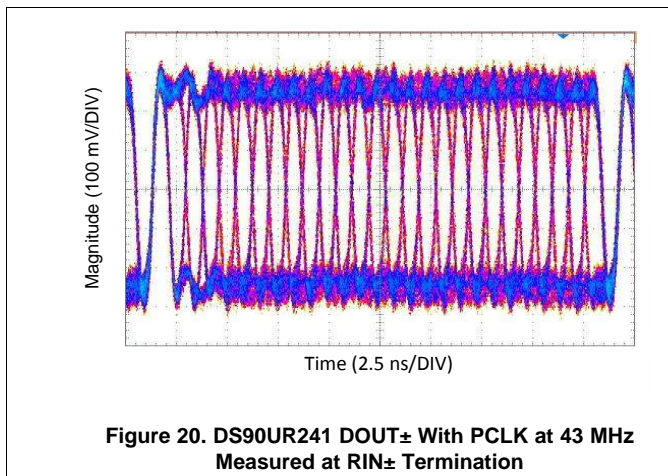

8 Detailed Description

8.1 Overview

The DS90UR241 Serializer and DS90UR124 Deserializer chipset is an easy-to-use transmitter and receiver pair that sends 24-bits of parallel LVCMOS data over a single serial LVDS link from 120 Mbps to 1.03 Gbps throughput. The DS90UR241 transforms a 24-bit wide parallel LVCMOS data into a single high speed LVDS serial data stream with embedded clock and scrambles / DC Balances the data to enhance signal quality to support AC coupling. The DS90UR124 receives the LVDS serial data stream and converts it back into a 24-bit wide parallel data and recovered clock. The 24-bit Serializer/Deserializer chipset is designed to transmit data up to 10 meters over shielded twisted pair (STP) at clock speeds from 5 MHz to 43 MHz.

The Deserializer can attain lock to a data stream without the use of a separate reference clock source, greatly simplifying system complexity and overall cost. The Deserializer synchronizes to the Serializer regardless of data pattern, delivering true automatic “plug and lock” performance. It will lock to the incoming serial stream without the need of special training patterns or sync characters. The Deserializer recovers the clock and data by extracting the embedded clock information and validating data integrity from the incoming data stream and then deserializes the data. The Deserializer monitors the incoming clock information, determines lock status, and asserts the LOCK output high when lock occurs.

In addition, the Deserializer also supports an optional @SPEED BIST (Built In Self Test) mode, BIST error flag, and LOCK status reporting pin. Signal quality on the wide parallel output is controlled by the SLEW control and bank slew (PTOSEL) inputs to help reduce noise and system EMI. Each device has a power down control to enable efficient operation in various applications.

8.2 Functional Block Diagram

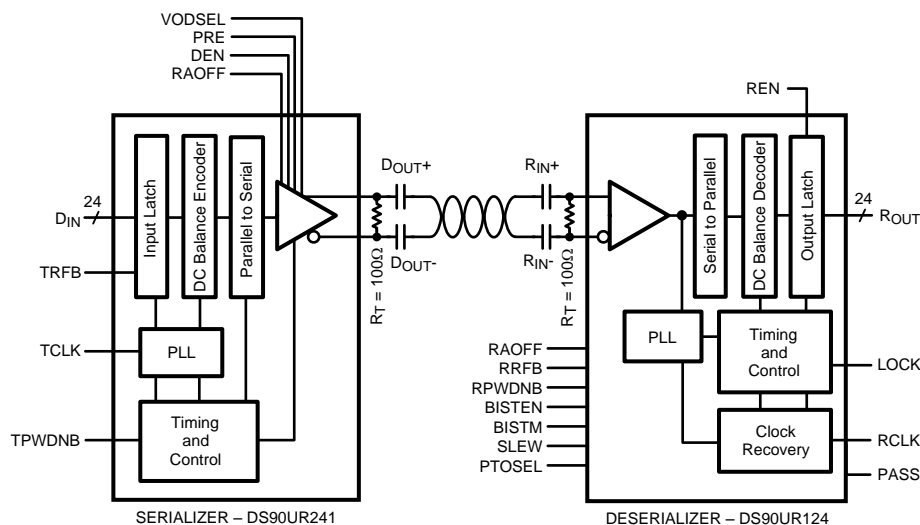

8.3 Feature Description

8.3.1 Initialization and Locking Mechanism

Initialization of the DS90UR241 and DS90UR124 must be established before each device sends or receives data. Initialization refers to synchronizing the Serializer’s and Deserializer’s PLL’s together. After the Serializers locks to the input clock source, the Deserializer synchronizes to the Serializers as the second and final initialization step.

Feature Description (continued)

Step 1: When V_{DD} is applied to both Serializer and/or Deserializer, the respective outputs are held in Tri-state and internal circuitry is disabled by on-chip power-on circuitry. When V_{DD} reaches $V_{DD\text{ OK}}$ (approximately 2.2 V) the PLL in Serializer begins locking to a clock input. For the Serializer, the local clock is the transmit clock, TCLK. The Serializer outputs are held in Tri-state while the PLL locks to the TCLK. After locking to TCLK, the Serializer block is now ready to send data patterns. The Deserializer output will remain in Tri-state while its PLL locks to the embedded clock information in serial data stream. Also, the Deserializer LOCK output will remain low until its PLL locks to incoming data and sync-pattern on the RIN_{\pm} pins.

Step 2: The Deserializer PLL acquires lock to a data stream without requiring the Serializer to send special patterns. The Serializer that is generating the stream to the Deserializer will automatically send random (non-repetitive) data patterns during this step of the Initialization State. The Deserializer will lock onto embedded clock within the specified amount of time. An embedded clock and data recovery (CDR) circuit locks to the incoming bit stream to recover the high-speed receive bit clock and re-time incoming data. The CDR circuit expects a coded input bit stream. In order for the Deserializer to lock to a random data stream from the Serializer, it performs a series of operations to identify the rising clock edge and validates data integrity, then locks to it. Because this locking procedure is independent on the data pattern, total random locking duration may vary. At the point when the Deserializer's CDR locks to the embedded clock, the LOCK pin goes high and valid RCLK/data appears on the outputs. Note that the LOCK signal is synchronous to valid data appearing on the outputs. The Deserializer's LOCK pin is a convenient way to ensure data integrity is achieved on receiver side.

8.3.2 Data Transfer

After Serializer lock is established, the inputs DIN_0 – DIN_{23} are used to input data to the Serializer. Data is clocked into the Serializer by the TCLK input. The edge of TCLK used to strobe the data is selectable via the TRFB pin. TRFB high selects the rising edge for clocking data and low selects the falling edge. The Serializer outputs ($DOUT_{\pm}$) are intended to drive point-to-point connections.

CLK_1 , CLK_0 , DCA, DCB are four overhead bits transmitted along the single LVDS serial data stream (Figure 30). The CLK_1 bit is always high and the CLK_0 bit is always low. The CLK_1 and CLK_0 bits function as the embedded clock bits in the serial stream. DCB functions as the DC Balance control bit. It does not require any pre-coding of data on transmit side. The DC Balance bit is used to minimize the short and long-term DC bias on the signal lines. This bit operates by selectively sending the data either unmodified or inverted. The DCA bit is used to validate data integrity in the embedded data stream. Both DCA and DCB coding schemes are integrated and automatically performed within Serializer and Deserializer.

The chipset supports clock frequency ranges of 5 MHz to 43 MHz. Every clock cycle, 24 databits are sent along with 4 additional overhead control bits. Thus the line rate is 1.20 Gbps maximum (140Mbps minimum). The link is extremely efficient at 86% (24/28). Twenty five (24 data + 1 clock) plus associated ground signals are reduced to only 1 single LVDS pair providing a compression ratio of better than 25 to 1.

In the serialized data stream, data/embedded clock & control bits (24+4 bits) are transmitted from the Serializer data output ($DOUT_{\pm}$) at 28 times the TCLK frequency. For example, if TCLK is 43 MHz, the serial rate is $43 \times 28 = 1.20$ Giga bits per second. Since only 24 bits are from input data, the serial "payload" rate is 24 times the TCLK frequency. For instance, if $TCLK = 43$ MHz, the payload data rate is $43 \times 24 = 1.03$ Gbps. TCLK is provided by the data source and must be in the range of 5 MHz to 43 MHz nominal. The Serializer outputs ($DOUT_{\pm}$) can drive a point-to-point connection as shown in Figure 29. The outputs transmit data when the enable pin (DEN) is high and TPWDNB is high. The DEN pin may be used to Tri-state the outputs when driven low.

When the Deserializer channel attains lock to the input from a Serializer, it drives its LOCK pin high and synchronously delivers valid data and recovered clock on the output. The Deserializer locks onto the embedded clock, uses it to generate multiple internal data strobes, and then drives the recovered clock to the RCLK pin. The recovered clock (RCLK output pin) is synchronous to the data on the $ROUT[23:0]$ pins. While LOCK is high, data on $ROUT[23:0]$ is valid. Otherwise, $ROUT[23:0]$ is invalid. The polarity of the RCLK edge is controlled by the RRFB input. $ROUT[23:0]$, LOCK and RCLK outputs will each drive a maximum of 4-pF load with a 43-MHz clock. REN controls Tri-state for $ROUT_n$ and the RCLK pin on the Deserializer.

Feature Description (continued)

8.3.3 Resynchronization

If the Deserializer loses lock, it will automatically try to re-establish lock. For example, if the embedded clock edge is not detected one time in succession, the PLL loses lock and the LOCK pin is driven low. The Deserializer then enters the operating mode where it tries to lock to a random data stream. It looks for the embedded clock edge, identifies it, and then proceeds through the locking process.

The logic state of the LOCK signal indicates whether the data on ROUT is valid; when it is high, the data is valid. The system may monitor the LOCK pin to determine whether data on the ROUT is valid.

8.3.4 Powerdown

The Powerdown state is a low power sleep mode that the Serializer and Deserializer may use to reduce power when no data is being transferred. The TPWDNB and RPWDNB are used to set each device into powerdown mode, which reduces supply current to the μA range. The Serializer enters powerdown when the TPWDNB pin is driven low. In powerdown, the PLL stops and the outputs go into Tri-state, disabling load current and reducing current supply. To exit Powerdown, TPWDNB must be driven high. When the Serializer exits Powerdown, its PLL must lock to TCLK before it is ready for the Initialization state. The system must then allow time for Initialization before data transfer can begin. The Deserializer enters powerdown mode when RPWDNB is driven low. In powerdown mode, the PLL stops and the outputs enter Tri-state. To bring the Deserializer block out of the powerdown state, the system drives RPWDNB high.

Both the Serializer and Deserializer must reinitialize and relock before data can be transferred. The Deserializer will initialize and assert LOCK high when it is locked to the embedded clock.

8.3.5 Tri-State

For the Serializer, Tri-state is entered when the DEN or TPWDNB pin is driven low. This will Tri-state both driver output pins (DOUT+ and DOUT-). When DEN is driven high, the serializer will return to the previous state as long as all other control pins remain static (TPWDNB, TRFB).

When you drive the REN or RPWDNB pin low, the Deserializer enters Tri-state. Consequently, the receiver output pins (ROUT0–ROUT23) and RCLK will enter Tri-state. The LOCK output remains active, reflecting the state of the PLL. The Deserializer input pins are high impedance during receiver powerdown (RPWDNB low) and power-off ($V_{DD} = 0\text{ V}$).

8.3.6 Pre-Emphasis

The DS90UR241 features a Pre-Emphasis function used to compensate for long or lossy transmission media. Cable drive is enhanced with a user selectable Pre-Emphasis feature that provides additional output current during transitions to counteract cable loading effects. The transmission distance will be limited by the loss characteristics and quality of the media. Pre-Emphasis adds extra current during LVDS logic transition to reduce the cable loading effects and increase driving distance. In addition, Pre-Emphasis helps provide faster transitions, increased eye openings, and improved signal integrity. The ability of the DS90UR241 to use the Pre-Emphasis feature will extend the transmission distance up to 10 meters in most cases.

To enable the Pre-Emphasis function, the "PRE" pin requires one external resistor (R_{pre}) to V_{ss} in order to set the additional current level. Values of R_{pre} should be between 6 k Ω and 100 M Ω . Values less than 6 k Ω should not be used. A lower input resistor value on the "PRE" pin increases the magnitude of dynamic current during data transition. The additional source current is based on the following formula: $PRE = (R_{PRE} \geq 6\text{ k}\Omega); I_{MAX} = [48 / R_{PRE}]$. For example if $R_{pre} = 15\text{ k}\Omega$, then the Pre-Emphasis current is increase by an additional 3.2 mA.

The amount of Pre-Emphasis for a given media will depend on the transmission distance of the application. In general, too much Pre-Emphasis can cause over or undershoot at the receiver input pins. This can result in excessive noise, crosstalk and increased power dissipation. For short cables or distances, Pre-Emphasis may not be required. Signal quality measurements are recommended to determine the proper amount of Pre-Emphasis for each application.

Feature Description (continued)

8.3.7 AC-Coupling and Termination

The DS90UR241 and DS90UR124 supports AC-coupled interconnects through integrated DC balanced encoding/decoding scheme. To use the Serializer and Deserializer in an AC-coupled application, insert external AC-coupling capacitors in series in the LVDS signal path as illustrated in [Figure 29](#). The Deserializer input stage is designed for AC-coupling by providing a built-in AC bias network which sets the internal V_{CM} to +1.8V. With AC signal coupling, capacitors provide the AC-coupling path to the signal input.

For the high-speed LVDS transmissions, the smallest available package should be used for the AC-coupling capacitor. This will help minimize degradation of signal quality due to package parasitics. The most common used capacitor value for the interface is a 100 nF (0.1 uF). NPO class 1 or X7R class 2 type capacitors are recommended. 50 WVDC should be the minimum used for the best system-level ESD performance.

A termination resistor across $DOUT_{\pm}$ and RIN_{\pm} is also required for proper operation to be obtained. The termination resistor should be equal to the differential impedance of the media being driven. This should be in the range of 90 to 132 Ω . 100 Ω is a typical value common used with standard 100- Ω transmission media. This resistor is required for control of reflections and also completes the current loop. It should be placed as close to the Serializer $DOUT_{\pm}$ outputs and Deserializer RIN_{\pm} inputs to minimize the stub length from the pins. To match with the differential impedance on the transmission line, the LVDS I/O are terminated with 100- Ω resistors on Serializer $DOUT_{\pm}$ outputs pins and Deserializer RIN_{\pm} input pins.

8.3.7.1 Receiver Termination Option 1

A single 100- Ω termination resistor is placed across the RIN_{\pm} pins (see [Figure 29](#)). This provides the signal termination at the Receiver inputs. Other options may be used to increase noise tolerance.

8.3.7.2 Receiver Termination Option 2

For additional EMI tolerance, two 50- Ω resistors may be used in place of the single 100- Ω resistor. A small capacitor is tied from the center point of the 50- Ω resistors to ground (see [Figure 31](#)). This provides a high-frequency low impedance path for noise suppression. Value is not critical, 4.7 nF may be used with general applications.

8.3.7.3 Receiver Termination Option 3

For high noise environments, an additional voltage divider network may be connected to the center point. This has the advantage of providing a DC low-impedance path for noise suppression. Use resistor values in the range of 100 Ω -2K Ω for the pullup and pulldown. Ratio the resistor values to bias the center point at 1.8 V. For example (see [Figure 32](#)): $V_{DD}=3.3$ V, $R_{pullup}=1$ K Ω , $R_{pulldown}=1.2$ K Ω ; or $R_{pullup}=100$ Ω , $R_{pulldown}=120$ Ω (strongest). The smaller values will consume more bias current, but will provide enhanced noise suppression.

8.3.8 Signal Quality Enhancers

The DS90UR124 Deserializer supports two signal quality enhancers. The SLEW pin is used to increase the drive strength of the LVCMOS outputs when driving heavy loads. SLEW allows output drive strength for high or low current drive. Default setting is LOW for low drive at 2 mA and HIGH for high drive at 4 mA.

There are two types of Progressive Turnon modes (Fixed and PTO Frequency Spread) to help reduce EMI: simultaneous switching noise and system ground bounce. The PTOSEL pin introduces bank skew in the data/clock outputs to limit the number of outputs switching simultaneously. For Fixed-PTO mode, the Deserializer $ROUT[23:0]$ outputs are grouped into three groups of eight, with each group switching about 2 or 1 UI apart in phase from RCLK for Group 1 and Groups 2, 3, respectively (see [Figure 17](#)). In the PTO Frequency Spread mode, $ROUT[23:0]$ are also grouped into three groups of eight, with each group is separated out of phase with the adjacent groups (see [Figure 18](#)) per every 4 cycles. Note that in the PTO Frequency Spread operating mode RCLK is also spreading and separated by 1 UI.

Feature Description (continued)

8.3.9 @SPEED-BIST Test Feature

To assist vendors with test verification, the DS90UR241 and DS90UR124 is equipped with built-in self-test (BIST) capability to support both system manufacturing and field diagnostics. BIST mode is intended to check the entire high-speed serial link at full link-speed, without the use of specialized and expensive test equipment. This feature provides a simple method for a system host to perform diagnostic testing of both Serializer and Deserializer. The BIST function is easily configured through the 2 control pins on the DS90UR124. When the BIST mode is activated, the Serializer has the ability to transfer an internally generated PRBS data pattern. This pattern traverses across interconnecting links to the Deserializer. The DS90UR124 includes an on-chip PRBS pattern verification circuit that checks the data pattern for bit errors and reports any errors on the data output pins on the Deserializer.

The @SPEED-BIST feature uses 2 signal pins (BISTEN and BISTM) on the DS90UR124 Deserializer. The BISTEN and BISTM pins together determine the functions of the BIST mode. The BISTEN signal (HIGH) activates the test feature on the Deserializer. After the BIST mode is enabled, all the data input channels DIN[23:0] on the DS90UR241 Serializer must be set logic LOW or floating in order for Deserializer to start accepting data. An input clock signal (TCLK) for the Serializer must also be applied during the entire BIST operation. The BISTM pin selects error reporting status mode of the BIST function. When BIST is configured in the error status mode (BISTM = LOW), each of the ROUT[23:0] outputs will correspond to bit errors on a cycle-by-cycle basis. The result of bit mismatches are indicated on the respective parallel inputs on the ROUT[23:0] data output pins. In the BIST error-count accumulator mode (BISTM = HIGH), an 8-bit counter on ROUT[7:0] is used to represent the number of errors detected (0 to 255 max). The successful completion of the BIST test is reported on the PASS pin on the Deserializer. The Deserializer's PLL must first be locked to ensure the PASS status is valid. The PASS status pin will stay LOW and then transition to HIGH once a BER of 1×10^{-9} is achieved across the transmission link.

8.3.10 Backward-Compatible Mode With DS90C241 and DS90C124

The RAOFF pin allows a backward-compatible mode with DS90C241 and DS90C124 devices. To interface with either DS90C241 Serializer or DS90C124 Deserializer, the RAOFF pin on DS90UR241 or DS90UR124 must be tied HIGH to disable the additional LSFR coding. For normal operation directly with DS90UR241 to DS90UR124, RAOFF pins are set LOW. See [Table 1](#) and [Table 2](#) for more details.

8.4 Device Functional Modes

Table 1. DS90UR241 Serializer Truth Table

TPWDNB (Pin 9)	DEN (Pin 18)	RAOFF (Pin 12)	Tx PLL Status (Internal)	LVDS Outputs (Pins 19 and 20)
L	X	X	X	Hi-Z
H	L	X	X	Hi-Z
H	H	X	Not Locked	Hi-Z
H	H	L	Locked	Serialized Data with Embedded Clock (DS90UR124 compatible)
H	H	H	Locked	Serialized Data with Embedded Clock (DS90C124 compatible)

Table 2. DS90UR124 Deserializer Truth Table

RPWDNB (Pin 48)	REN (Pin 60)	RAOFF (Pin 63)	Rx PLL Status (Internal)	ROUTn and RCLK (See Pin Diagram)	LOCK (Pin 23)
L	X	X	X	Hi Z	Hi Z
H	L	X	X	Hi Z	L = PLL Unlocked; H = PLL Locked
H	H	X	Not Locked	Hi Z	L
H	H	L	Locked	Data and RCLK Active (DS90UR241 compatible)	H
H	H	H	Locked	Data and RCLK Active (DS90C241 compatible)	H

9 Application and Implementation

NOTE

Information in the following applications sections is not part of the TI component specification, and TI does not warrant its accuracy or completeness. TI's customers are responsible for determining suitability of components for their purposes. Customers should validate and test their design implementation to confirm system functionality.

9.1 Application Information

9.1.1 Using the DS90UR241 and DS90UR124

The DS90UR241/DS90UR124 Serializer/Deserializer (SERDES) pair sends 24 bits of parallel LVCMOS data over a serial LVDS link up to 1.03 Gbps. Serialization of the input data is accomplished using an onboard PLL at the Serializer which embeds clock with the data. The Deserializer extracts the clock/control information from the incoming data stream and deserializes the data. The Deserializer monitors the incoming clock information to determine lock status and will indicate lock by asserting the LOCK output high.

9.1.2 Display Application

The DS90URxxx-Q1 chipset is intended for interface between a host (graphics processor) and a Display. It supports an 18-bit color depth (RGB666) and up to 1280 × 480 display formats. In a RGB666 configuration 18 color bits (R[5:0], G[5:0], B[5:0]), Pixel Clock (PCLK) and 3 control bits (VS, HS and DE) along with 3 spare bits are supported across the serial link with PCLK rates from 5 to 43 MHz.

9.1.3 Typical Application Connection

[Figure 22](#) shows a typical application of the DS90UR241 Serializer (SER). The LVDS outputs use a 100-Ω termination and 100-nF coupling capacitors to the line. Bypass capacitors are placed near the power supply pins. At a minimum, three 0.1-μF capacitors should be used for local bypassing. A system GPO (General Purpose Output) controls the TPWDNB pin. In this application the TRFB pin is tied High to latch data on the rising edge of the TCLK. The DEN signal is not used and is tied High also. The application is to the companion Deserializer (DS90UR124) so the RAOFF pin is tied low to scramble the data and improve link signal quality. In this application the link is typical, therefore the VODSEL pin is tied Low for the standard LVDS swing. The pre-emphasis input uses a resistor to ground to set the amount of pre-emphasis desired by the application.

[Figure 26](#) shows a typical application of the DS90UR124 Deserializer (DES). The LVDS inputs use a 100-Ω termination and 100-nF coupling capacitors to the line. Bypass capacitors are placed near the power supply pins. At a minimum, four 0.1-μF capacitors should be used for local bypassing. A system GPO (general-purpose output) controls the RPWDNB pin. In this application the RRFB pin is tied High to strobe the data on the rising edge of the RCLK. The REN signal is not used and is tied High also. The application is to the companion Serializer (DS90UR241) so the RAOFF pin is tied low to descramble the data. Output (LVCMOS) signal quality is set by the SLEW pin, and the PTOSEL pin can be used to reduce simultaneous output switching by introducing a small amount of delay between output banks.

9.2 Typical Applications

9.2.1 DS90UR241-Q1 Typical Application Connection

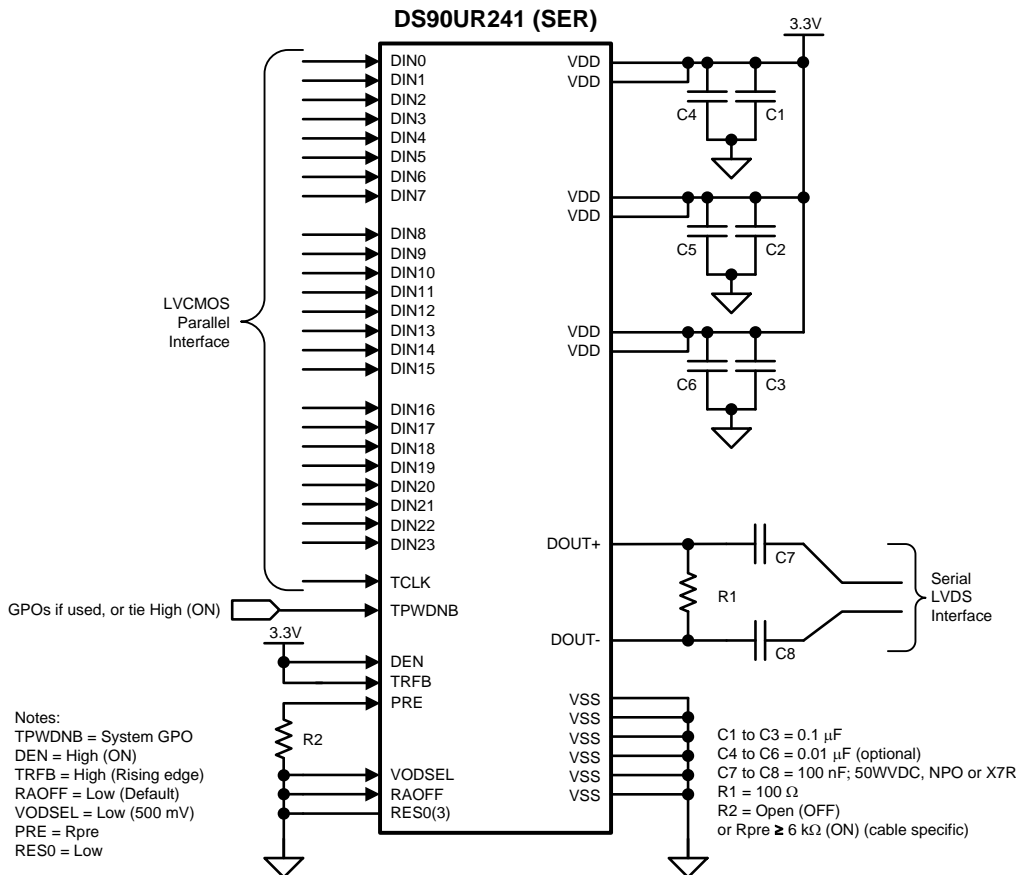

Figure 22. DS90UR241 Connection Diagram

9.2.1.1 Design Requirements

Table 3. DS90UR241 Design Parameter

DESIGN PARAMETER	EXAMPLE VALUE
VDD	3.3 V
AC Coupling Capacitor for DOU \pm	100 nF
DOU \pm External Termination	100 Ω
PCLK Frequency	33 MHz

9.2.1.2 Detailed Design Procedure

Figure 22 shows a typical application of the DS90UR241 serializer for an 33-MHz 18-bit Color Display Application. The DOU \pm outputs must have a series external 0.1- μ F AC-coupling capacitor and 100- Ω parallel termination on the high-speed serial lines. The serializer does not have an internal termination. Bypass capacitors are placed near the power supply pins. At a minimum, three 0.1- μ F capacitors should be used for local device bypassing. Additional capacitors may be needed as the number and values of the capacitors will depend on meeting the power noise specification of the part. Ferrite beads may be needed on the VDDs for effective noise suppression. The interface to the graphics source is with 3.3-V LVC MOS levels. An RC delay is placed on the PDB signal to delay the enabling of the device until power is stable.

9.2.1.2.1 Power Considerations

An all LVCMOS design of the Serializer and Deserializer makes them inherently low-power devices. Additionally, the constant current source nature of the LVDS outputs minimizes the slope of the speed vs. I_{DD} curve of LVCMOS designs.

9.2.1.2.2 Noise Margin

The Deserializer noise margin is the amount of input jitter (phase noise) that the Deserializer can tolerate and still reliably recover data. Various environmental and systematic factors include:

- Serializer: V_{DD} noise, TCLK jitter (noise bandwidth and out-of-band noise)
- Media: ISI, V_{CM} noise
- Deserializer: V_{DD} noise

For a graphical representation of noise margin, see [Figure 19](#).

9.2.1.2.3 Transmission Media

The Serializer and Deserializer are to be used in point-to-point configuration, through a PCB trace, or through twisted pair cable. In a point-to-point configuration, the transmission media needs be terminated at both ends of the transmitter and receiver pair. Interconnect for LVDS typically has a differential impedance of 100 Ω . Use cables and connectors that have matched differential impedance to minimize impedance discontinuities. In most applications that involve cables, the transmission distance will be determined on data rates involved, acceptable bit error rate and transmission medium.

The resulting signal quality at the receiving end of the transmission media may be assessed by monitoring the differential eye opening of the serial data stream. The Receiver Input Tolerance and Differential Threshold Voltage specifications define the acceptable data eye opening. A differential probe should be used to measure across the termination resistor at the DS90UR124 inputs. [Figure 23](#) illustrates the eye opening and relationship to the Receiver Input Tolerance and Differential Threshold Voltage specifications.

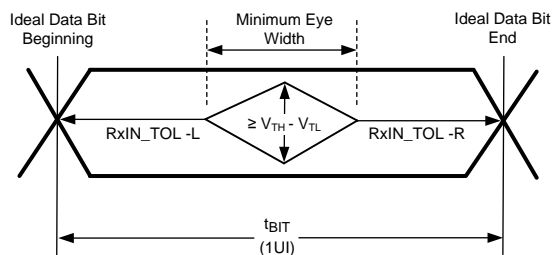

Figure 23. Receiver Input Eye Opening

9.2.1.2.4 Live Link Insertion

The Serializer and Deserializer devices support live pluggable applications. The automatic receiver lock to random data “plug and go” hot insertion capability allows the DS90UR124 to attain lock to the active data stream during a live insertion event.

9.2.1.3 Application Curves

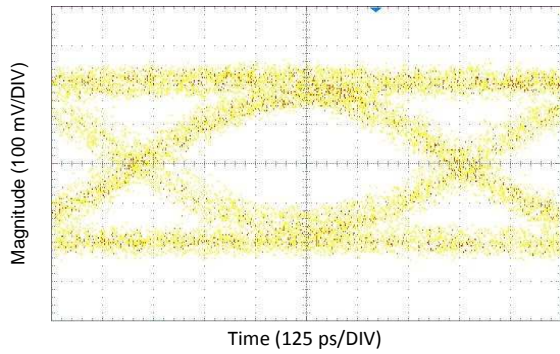

Figure 24. DS90UR241 DOUT± at 1.2 Gbps Measured at RIN± Termination; VODSEL=LOW

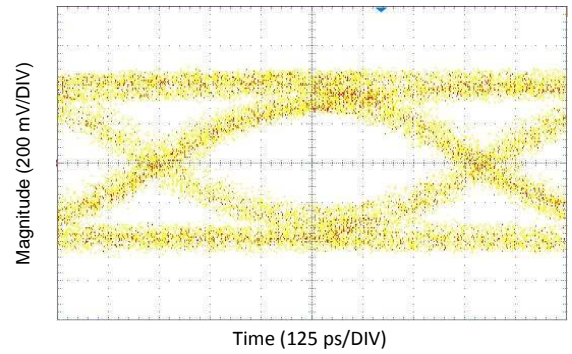

Figure 25. DS90UR241 DOUT± at 1.2 Gbps Measured at RIN± Termination; VODSEL=HIGH

9.2.2 DS90UR124 Typical Application Connection

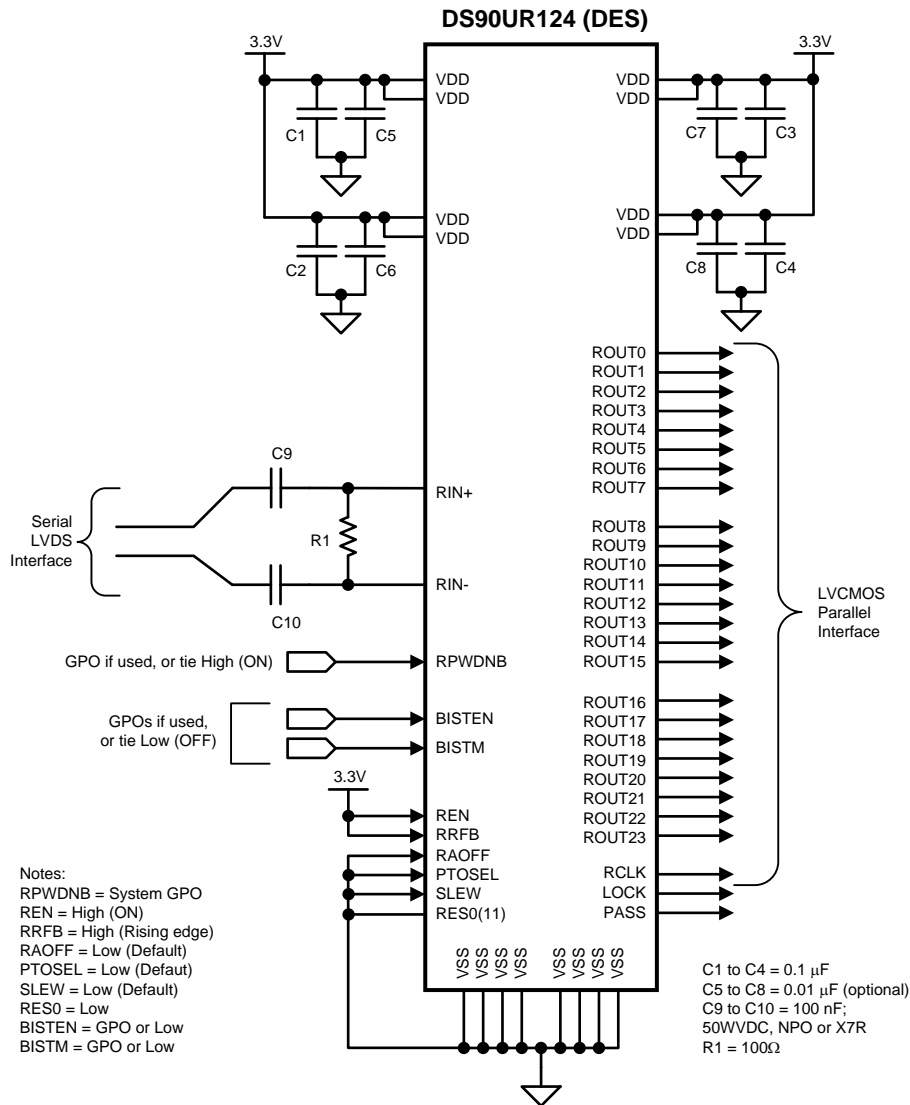

Figure 26. DS90UR124 Connection Diagram

9.2.2.1 Design Requirements

Table 4. DS90UR124 Design Parameters

DESIGN PARAMETER	EXAMPLE VALUE
VDD	3.3 V
DS90UR124-Q1 AC-Coupling Capacitor for RIN±	100 nF
DS90UR124-Q1 Termination for RIN±	100 Ω

9.2.2.2 Detailed Design Procedure

Figure 26 shows a typical application of the DS90UR124 deserializer for an 33-MHz 18-bit Color Display Application. The RIN_{\pm} inputs must have an external series 0.1- μ F AC-coupling capacitor and 100- Ω parallel termination on the high-speed serial lines. The deserializer does not have an internal termination. Bypass capacitors are placed near the power supply pins. At a minimum, four 0.1- μ F capacitors should be used for local device bypassing. Ferrite beads may be needed on the VDDs for effective noise suppression. Additional capacitors may be needed as the number and values of the capacitors will depend on meeting the power noise specification of the part. The interface to the display is with 3.3-V LVCMOS levels. An RC delay is placed on the PDB signal to delay the enabling of the device until power is stable.

9.2.2.3 Application Curves

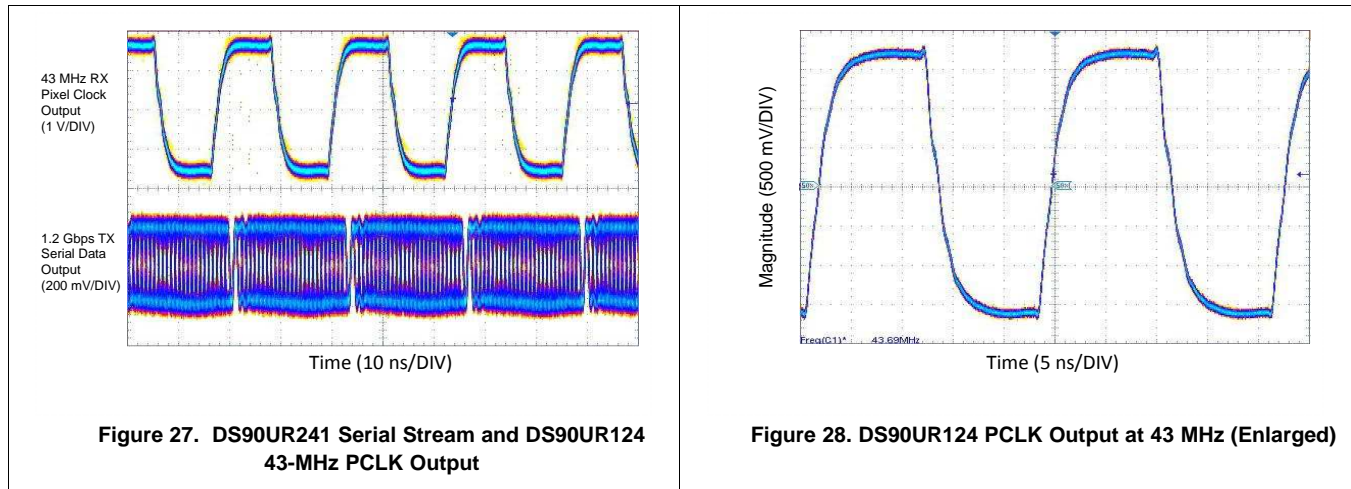

10 Power Supply Recommendations

This device is designed to operate from an input core voltage supply of 3.3 V. Some devices provide separate power and ground pins for different portions of the circuit. This is done to isolate switching noise effects between different sections of the circuit. Separate planes on the PCB are typically. Pin description tables typically provide guidance on which circuit blocks are connected to which power pin pairs. In some cases, an external filter may be used to provide clean power to sensitive circuits such as PLLs.

11 Layout

11.1 Layout Guidelines

11.1.1 PCB Layout and Power System Considerations

Circuit board layout and stack-up for the LVDS SERDES devices should be designed to provide low-noise power feed to the device. Good layout practice will also separate high-frequency or high-level inputs and outputs to minimize unwanted stray noise pickup, feedback and interference. Power system performance may be greatly improved by using thin dielectrics (2 to 4 mils) for power / ground sandwiches. This arrangement provides plane capacitance for the PCB power system with low-inductance parasitics, which has proven especially effective at high frequencies, and makes the value and placement of external bypass capacitors less critical. External bypass capacitors should include both RF ceramic and tantalum electrolytic types. RF capacitors may use values in the range of 0.01 μF to 0.1 μF . Tantalum capacitors may be in the range of 2.2 μF to 10 μF . Voltage rating of the tantalum capacitors should be at least 5 \times the power supply voltage being used.

Surface-mount capacitors are recommended due to their smaller parasitics. When using multiple capacitors per supply pin, locate the smaller value closer to the pin. A large bulk capacitor is recommended at the point of power entry. This is typically in the 50- μF to 100- μF range and will smooth low frequency switching noise. TI recommends connecting power and ground pins directly to the power and ground planes with bypass capacitors connected to the plane with via on both ends of the capacitor. Connecting power or ground pins to an external bypass capacitor will increase the inductance of the path.

A small body size X7R chip capacitor, such as 0603, is recommended for external bypass. Its small body size reduces the parasitic inductance of the capacitor. The user must pay attention to the resonance frequency of these external bypass capacitors, usually in the range of 20 MHz to 30 MHz. To provide effective bypassing, multiple capacitors are often used to achieve low impedance between the supply rails over the frequency of interest. At high frequency, it is also a common practice to use two vias from power and ground pins to the planes, reducing the impedance at high frequency.

Some devices provide separate power and ground pins for different portions of the circuit. This is done to isolate switching noise effects between different sections of the circuit. Separate planes on the PCB are typically not required. Pin description tables typically provide guidance on which circuit blocks are connected to which power pin pairs. In some cases, an external filter may be used to provide clean power to sensitive circuits such as PLLs.

Use at least a 4-layer board with a power and ground plane. Locate LVCMOS signals away from the LVDS lines to prevent coupling from the LVCMOS lines to the LVDS lines. Closely coupled differential lines of 100 Ω are typically recommended for LVDS interconnect. The closely coupled lines help to ensure that coupled noise will appear as common-mode and thus is rejected by the receivers. The tightly coupled lines will also radiate less.

Termination of the LVDS interconnect is required. For point-to-point applications, termination should be located at both ends of the devices. Nominal value is 100 Ω to match the differential impedance of the line. Place the resistor as close to the transmitter DOUT \pm outputs and receiver RIN \pm inputs as possible to minimize the resulting stub between the termination resistor and device.

11.1.2 LVDS Interconnect Guidelines

See AN-1108 ([SNLA008](#)) and AN-905 ([SNLA035](#)) for full details.

- Use 100- Ω coupled differential pairs
- Use the S/2S/3S rule in spacings
 - S = space between the pair
 - 2S = space between pairs
 - 3S = space to LVCMOS signal
- Minimize the number of vias
- Use differential connectors when operating above 500-Mbps line speed
- Maintain balance of the traces
- Minimize skew within the pair
- Terminate as close to the TX outputs and RX inputs as possible

Layout Guidelines (continued)

Additional general guidance can be found in the *LVDS Owner's Manual (SNLA187)* - available in PDF format from the TI web site at: www.ti.com/lvds

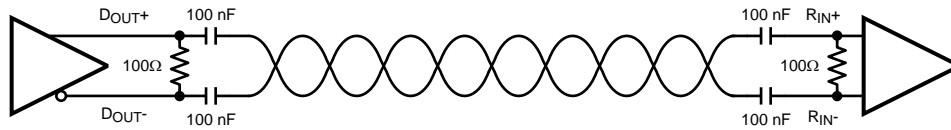
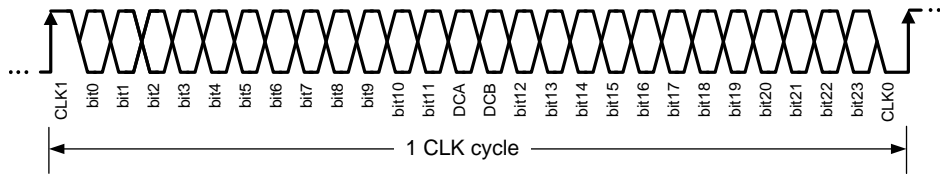

Figure 29. AC-Coupled Application



*Note: bits [0-23] are not physically located in positions shown above since bits [0-23] are scrambled and DC Balanced

Figure 30. Single Serialized LVDS Bitstream*

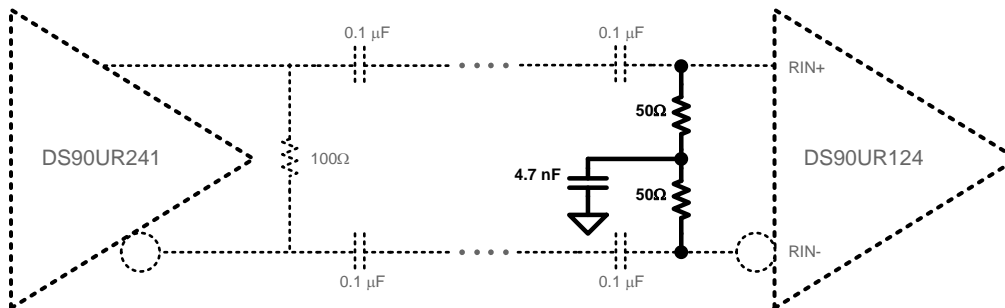

Figure 31. Receiver Termination Option 2

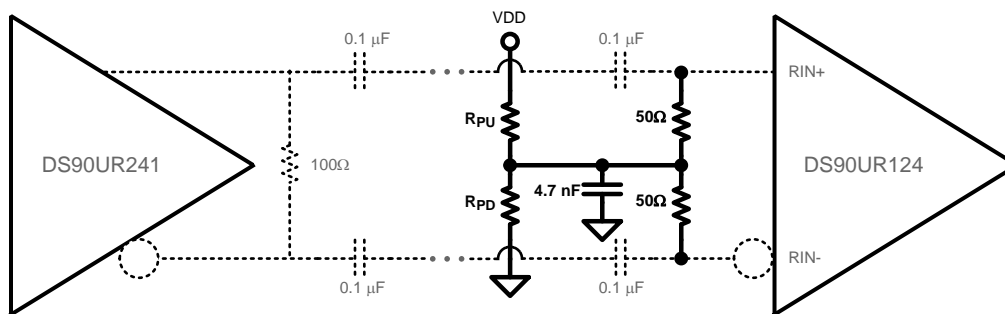

Figure 32. Receiver Termination Option 3

11.2 Layout Examples

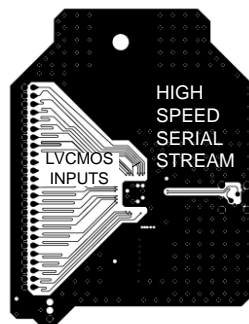

Figure 33. Example DS90UR241-Q1 EMC Layout



Figure 34. DS90UR241-Q1 EMC EVM Layer 4

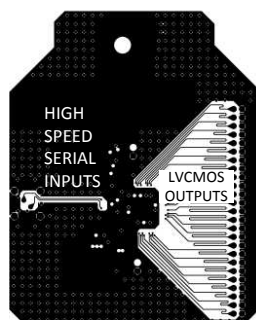

Figure 35. Example DS90UR124-Q1 EMC Layout

Layout Examples (continued)



Figure 36. DS90UR124-Q1 EMC EVM Layer 4

12 Device and Documentation Support

12.1 Device Support

12.1.1 Third-Party Products Disclaimer

TI'S PUBLICATION OF INFORMATION REGARDING THIRD-PARTY PRODUCTS OR SERVICES DOES NOT CONSTITUTE AN ENDORSEMENT REGARDING THE SUITABILITY OF SUCH PRODUCTS OR SERVICES OR A WARRANTY, REPRESENTATION OR ENDORSEMENT OF SUCH PRODUCTS OR SERVICES, EITHER ALONE OR IN COMBINATION WITH ANY TI PRODUCT OR SERVICE.

12.2 Documentation Support

12.2.1 Related Documentation

For related documentation see the following:

- *LVDS Interconnect Guidelines AN-1108*, [SNLA008](#)
- *LVDS Interconnect Guidelines AN-905*, [SNLA035](#)

12.3 Related Links

The table below lists quick access links. Categories include technical documents, support and community resources, tools and software, and quick access to sample or buy.

Table 5. Related Links

PARTS	PRODUCT FOLDER	SAMPLE & BUY	TECHNICAL DOCUMENTS	TOOLS & SOFTWARE	SUPPORT & COMMUNITY
DS90UR124-Q1	Click here	Click here	Click here	Click here	Click here
DS90UR241-Q1	Click here	Click here	Click here	Click here	Click here

12.4 Trademarks

All trademarks are the property of their respective owners.

12.5 Electrostatic Discharge Caution



These devices have limited built-in ESD protection. The leads should be shorted together or the device placed in conductive foam during storage or handling to prevent electrostatic damage to the MOS gates.

12.6 Glossary

[SLYZ022](#) — *TI Glossary*.

This glossary lists and explains terms, acronyms, and definitions.

13 Mechanical, Packaging, and Orderable Information

The following pages include mechanical, packaging, and orderable information. This information is the most current data available for the designated devices. This data is subject to change without notice and revision of this document. For browser-based versions of this data sheet, refer to the left-hand navigation.

PACKAGING INFORMATION

Orderable Device	Status (1)	Package Type	Package Drawing	Pins	Package Qty	Eco Plan (2)	Lead/Ball Finish (6)	MSL Peak Temp (3)	Op Temp (°C)	Device Marking (4/5)	Samples
DS90UR124IVS/NOPB	ACTIVE	TQFP	PAG	64	160	Green (RoHS & no Sb/Br)	CU SN	Level-3-260C-168 HR	-40 to 105	DS90UR124 IVS	Samples
DS90UR124IVSX/NOPB	ACTIVE	TQFP	PAG	64	1000	Green (RoHS & no Sb/Br)	CU SN	Level-3-260C-168 HR	-40 to 105	DS90UR124 IVS	Samples
DS90UR124QVS/NOPB	ACTIVE	TQFP	PAG	64	160	Green (RoHS & no Sb/Br)	CU SN	Level-3-260C-168 HR	-40 to 105	DS90UR124 QVS	Samples
DS90UR124QVSX/NOPB	ACTIVE	TQFP	PAG	64	1000	Green (RoHS & no Sb/Br)	CU SN	Level-3-260C-168 HR	-40 to 105	DS90UR124 QVS	Samples
DS90UR241IVS/NOPB	ACTIVE	TQFP	PFB	48	250	Green (RoHS & no Sb/Br)	CU SN	Level-3-260C-168 HR	-40 to 105	DS90UR24 1VS	Samples
DS90UR241IVSX/NOPB	ACTIVE	TQFP	PFB	48	1000	Green (RoHS & no Sb/Br)	CU SN	Level-3-260C-168 HR	-40 to 105	DS90UR24 1VS	Samples
DS90UR241QVS/NOPB	ACTIVE	TQFP	PFB	48	250	Green (RoHS & no Sb/Br)	CU SN	Level-3-260C-168 HR	-40 to 105	DS90UR24 1QVS	Samples
DS90UR241QVSX/NOPB	ACTIVE	TQFP	PFB	48	1000	Green (RoHS & no Sb/Br)	CU SN	Level-3-260C-168 HR	-40 to 105	DS90UR24 1QVS	Samples

(1) The marketing status values are defined as follows:

ACTIVE: Product device recommended for new designs.

LIFEBUY: TI has announced that the device will be discontinued, and a lifetime-buy period is in effect.

NRND: Not recommended for new designs. Device is in production to support existing customers, but TI does not recommend using this part in a new design.

PREVIEW: Device has been announced but is not in production. Samples may or may not be available.

OBSOLETE: TI has discontinued the production of the device.

(2) Eco Plan - The planned eco-friendly classification: Pb-Free (RoHS), Pb-Free (RoHS Exempt), or Green (RoHS & no Sb/Br) - please check <http://www.ti.com/productcontent> for the latest availability information and additional product content details.

TBD: The Pb-Free/Green conversion plan has not been defined.

Pb-Free (RoHS): TI's terms "Lead-Free" or "Pb-Free" mean semiconductor products that are compatible with the current RoHS requirements for all 6 substances, including the requirement that lead not exceed 0.1% by weight in homogeneous materials. Where designed to be soldered at high temperatures, TI Pb-Free products are suitable for use in specified lead-free processes.

Pb-Free (RoHS Exempt): This component has a RoHS exemption for either 1) lead-based flip-chip solder bumps used between the die and package, or 2) lead-based die adhesive used between the die and leadframe. The component is otherwise considered Pb-Free (RoHS compatible) as defined above.

Green (RoHS & no Sb/Br): TI defines "Green" to mean Pb-Free (RoHS compatible), and free of Bromine (Br) and Antimony (Sb) based flame retardants (Br or Sb do not exceed 0.1% by weight in homogeneous material)

(3) MSL, Peak Temp. - The Moisture Sensitivity Level rating according to the JEDEC industry standard classifications, and peak solder temperature.

(4) There may be additional marking, which relates to the logo, the lot trace code information, or the environmental category on the device.

(5) Multiple Device Markings will be inside parentheses. Only one Device Marking contained in parentheses and separated by a "~" will appear on a device. If a line is indented then it is a continuation of the previous line and the two combined represent the entire Device Marking for that device.

(6) Lead/Ball Finish - Orderable Devices may have multiple material finish options. Finish options are separated by a vertical ruled line. Lead/Ball Finish values may wrap to two lines if the finish value exceeds the maximum column width.

Important Information and Disclaimer:The information provided on this page represents TI's knowledge and belief as of the date that it is provided. TI bases its knowledge and belief on information provided by third parties, and makes no representation or warranty as to the accuracy of such information. Efforts are underway to better integrate information from third parties. TI has taken and continues to take reasonable steps to provide representative and accurate information but may not have conducted destructive testing or chemical analysis on incoming materials and chemicals. TI and TI suppliers consider certain information to be proprietary, and thus CAS numbers and other limited information may not be available for release.

In no event shall TI's liability arising out of such information exceed the total purchase price of the TI part(s) at issue in this document sold by TI to Customer on an annual basis.

OTHER QUALIFIED VERSIONS OF DS90UR124, DS90UR124-Q1, DS90UR241, DS90UR241-Q1 :

- Catalog: [DS90UR124](#), [DS90UR241](#)
- Automotive: [DS90UR124-Q1](#), [DS90UR241-Q1](#)

NOTE: Qualified Version Definitions:

- Catalog - TI's standard catalog product
- Automotive - Q100 devices qualified for high-reliability automotive applications targeting zero defects

TAPE AND REEL INFORMATION

QUADRANT ASSIGNMENTS FOR PIN 1 ORIENTATION IN TAPE

*All dimensions are nominal

Device	Package Type	Package Drawing	Pins	SPQ	Reel Diameter (mm)	Reel Width W1 (mm)	A0 (mm)	B0 (mm)	K0 (mm)	P1 (mm)	W (mm)	Pin1 Quadrant
DS90UR124IVSX/NOPB	TQFP	PAG	64	1000	330.0	24.4	13.0	13.0	1.45	16.0	24.0	Q2
DS90UR124QVSX/NOPB	TQFP	PAG	64	1000	330.0	24.4	13.0	13.0	1.45	16.0	24.0	Q2
DS90UR241IVSX/NOPB	TQFP	PFB	48	1000	330.0	16.4	9.3	9.3	2.2	12.0	16.0	Q2
DS90UR241QVSX/NOPB	TQFP	PFB	48	1000	330.0	16.4	9.3	9.3	2.2	12.0	16.0	Q2

TAPE AND REEL BOX DIMENSIONS

*All dimensions are nominal

Device	Package Type	Package Drawing	Pins	SPQ	Length (mm)	Width (mm)	Height (mm)
DS90UR124IVSX/NOPB	TQFP	PAG	64	1000	367.0	367.0	45.0
DS90UR124QVSX/NOPB	TQFP	PAG	64	1000	367.0	367.0	45.0
DS90UR241IVSX/NOPB	TQFP	PFB	48	1000	367.0	367.0	38.0
DS90UR241QVSX/NOPB	TQFP	PFB	48	1000	367.0	367.0	38.0

PAG (S-PQFP-G64)

PLASTIC QUAD FLATPACK

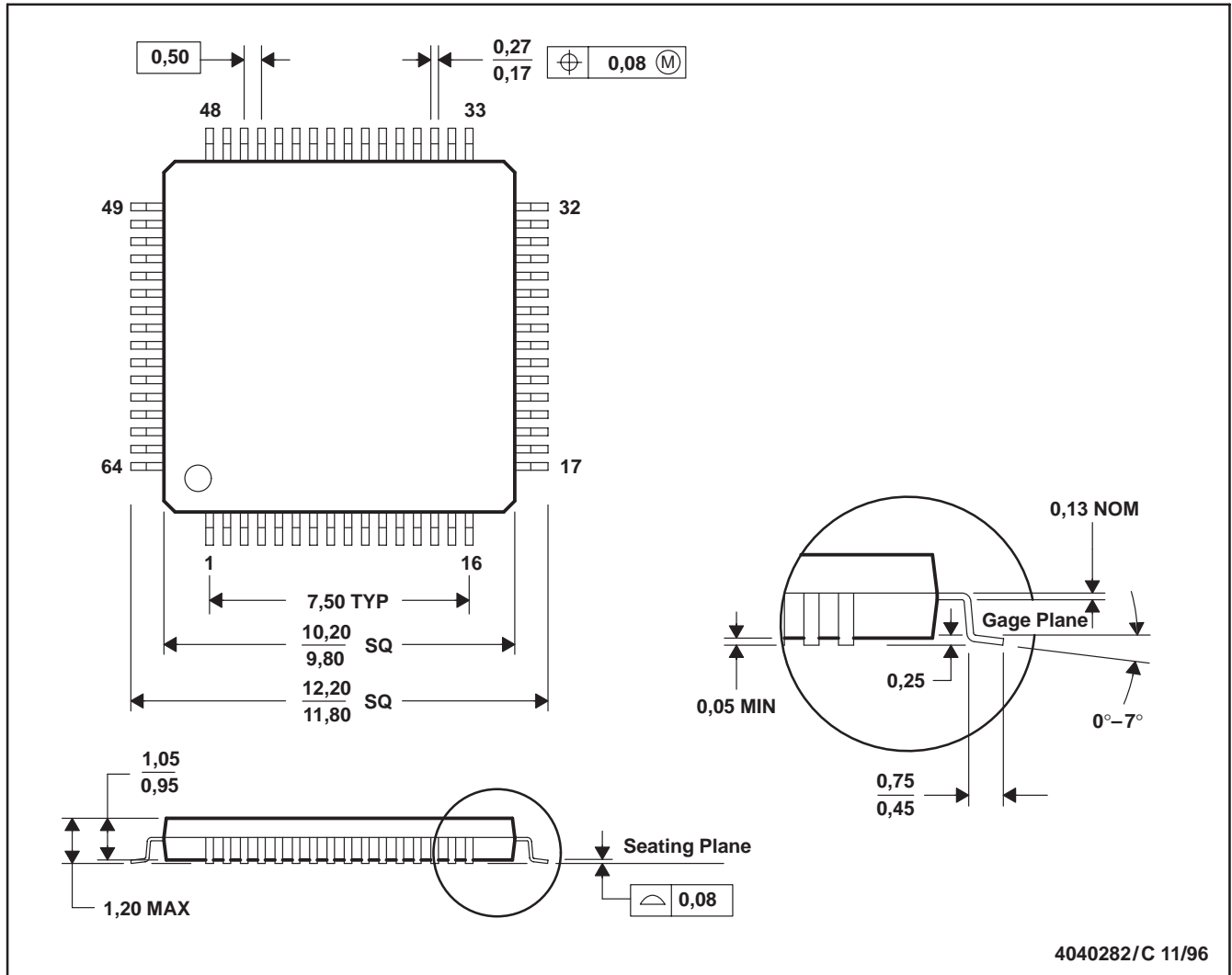

- NOTES: A. All linear dimensions are in millimeters.
 B. This drawing is subject to change without notice.
 C. Falls within JEDEC MS-026

PFB (S-PQFP-G48)

PLASTIC QUAD FLATPACK

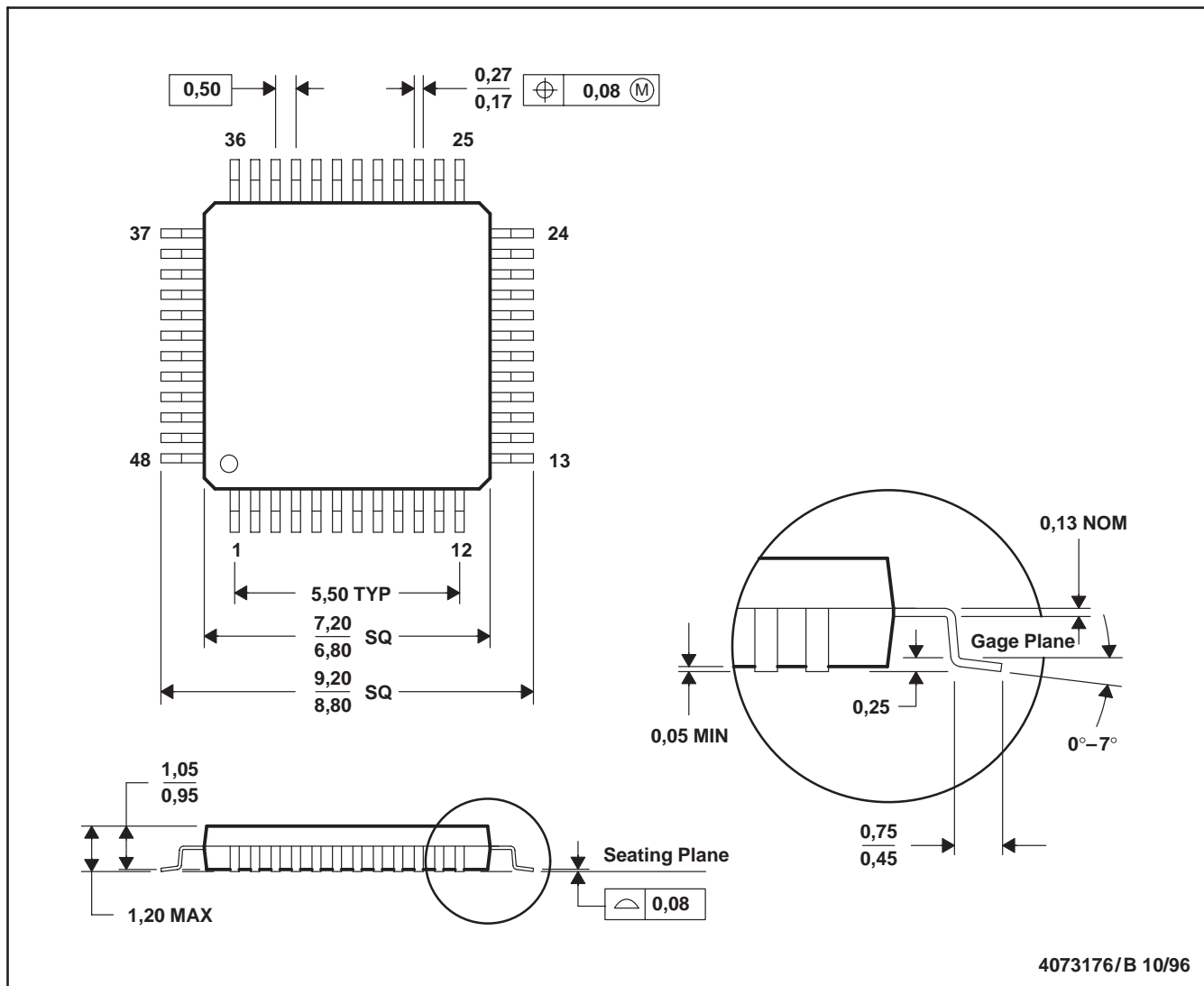

- NOTES: A. All linear dimensions are in millimeters.
 B. This drawing is subject to change without notice.
 C. Falls within JEDEC MS-026

IMPORTANT NOTICE

Texas Instruments Incorporated and its subsidiaries (TI) reserve the right to make corrections, enhancements, improvements and other changes to its semiconductor products and services per JESD46, latest issue, and to discontinue any product or service per JESD48, latest issue. Buyers should obtain the latest relevant information before placing orders and should verify that such information is current and complete. All semiconductor products (also referred to herein as "components") are sold subject to TI's terms and conditions of sale supplied at the time of order acknowledgment.

TI warrants performance of its components to the specifications applicable at the time of sale, in accordance with the warranty in TI's terms and conditions of sale of semiconductor products. Testing and other quality control techniques are used to the extent TI deems necessary to support this warranty. Except where mandated by applicable law, testing of all parameters of each component is not necessarily performed.

TI assumes no liability for applications assistance or the design of Buyers' products. Buyers are responsible for their products and applications using TI components. To minimize the risks associated with Buyers' products and applications, Buyers should provide adequate design and operating safeguards.

TI does not warrant or represent that any license, either express or implied, is granted under any patent right, copyright, mask work right, or other intellectual property right relating to any combination, machine, or process in which TI components or services are used. Information published by TI regarding third-party products or services does not constitute a license to use such products or services or a warranty or endorsement thereof. Use of such information may require a license from a third party under the patents or other intellectual property of the third party, or a license from TI under the patents or other intellectual property of TI.

Reproduction of significant portions of TI information in TI data books or data sheets is permissible only if reproduction is without alteration and is accompanied by all associated warranties, conditions, limitations, and notices. TI is not responsible or liable for such altered documentation. Information of third parties may be subject to additional restrictions.

Resale of TI components or services with statements different from or beyond the parameters stated by TI for that component or service voids all express and any implied warranties for the associated TI component or service and is an unfair and deceptive business practice. TI is not responsible or liable for any such statements.

Buyer acknowledges and agrees that it is solely responsible for compliance with all legal, regulatory and safety-related requirements concerning its products, and any use of TI components in its applications, notwithstanding any applications-related information or support that may be provided by TI. Buyer represents and agrees that it has all the necessary expertise to create and implement safeguards which anticipate dangerous consequences of failures, monitor failures and their consequences, lessen the likelihood of failures that might cause harm and take appropriate remedial actions. Buyer will fully indemnify TI and its representatives against any damages arising out of the use of any TI components in safety-critical applications.

In some cases, TI components may be promoted specifically to facilitate safety-related applications. With such components, TI's goal is to help enable customers to design and create their own end-product solutions that meet applicable functional safety standards and requirements. Nonetheless, such components are subject to these terms.

No TI components are authorized for use in FDA Class III (or similar life-critical medical equipment) unless authorized officers of the parties have executed a special agreement specifically governing such use.

Only those TI components which TI has specifically designated as military grade or "enhanced plastic" are designed and intended for use in military/aerospace applications or environments. Buyer acknowledges and agrees that any military or aerospace use of TI components which have **not** been so designated is solely at the Buyer's risk, and that Buyer is solely responsible for compliance with all legal and regulatory requirements in connection with such use.

TI has specifically designated certain components as meeting ISO/TS16949 requirements, mainly for automotive use. In any case of use of non-designated products, TI will not be responsible for any failure to meet ISO/TS16949.

Products

Audio	www.ti.com/audio
Amplifiers	amplifier.ti.com
Data Converters	dataconverter.ti.com
DLP® Products	www.dlp.com
DSP	dsp.ti.com
Clocks and Timers	www.ti.com/clocks
Interface	interface.ti.com
Logic	logic.ti.com
Power Mgmt	power.ti.com
Microcontrollers	microcontroller.ti.com
RFID	www.ti-rfid.com
OMAP Applications Processors	www.ti.com/omap
Wireless Connectivity	www.ti.com/wirelessconnectivity

Applications

Automotive and Transportation	www.ti.com/automotive
Communications and Telecom	www.ti.com/communications
Computers and Peripherals	www.ti.com/computers
Consumer Electronics	www.ti.com/consumer-apps
Energy and Lighting	www.ti.com/energy
Industrial	www.ti.com/industrial
Medical	www.ti.com/medical
Security	www.ti.com/security
Space, Avionics and Defense	www.ti.com/space-avionics-defense
Video and Imaging	www.ti.com/video

TI E2E Community

e2e.ti.com

Looking for pricing, stock, or lifecycle information?

Click below to explore more details on WIN SOURCE:

 [View DS90UR124IVSX/NOPB on WIN SOURCE](#)

 [Texas Instruments](#) Information

Optimize Your Supply Chain with WIN SOURCE Solutions

-  Global Sourcing Solution
-  Obsolete Management
-  Cost Control Management
-  Shortage Management
-  Alternative Solution
-  Excess Inventory Management