



**THE DATASHEET OF**  
**173010378**





**7 - 28V / 1A / 3.3 and 5V Output**

**DESCRIPTION**

The FDSM series of the MagI<sup>3</sup>C power module family is a fixed output voltage, fully integrated dc/dc power supply. The module integrates the switching power stage, control circuitry inductor and capacitors all in one package.

The module requires no external components for operation. Input and output capacitors are integrated. Design effort and complexity is reduced to a minimum.

The FDSM ensures fast time to market and low development costs.

It is pin compatible with the common 78xx linear regulator series. The high efficiency reduces the power dissipation and in many cases heatsink and assembly parts are no longer necessary.

Typical 12V to 3.3V conversion achieves 87% efficiency.  
Typical 12V to 5V conversion achieves 91% efficiency.

The standard THT package allows for easy assembly.

**TYPICAL APPLICATIONS**

- Point-of-Load from 18V, 15V, 12V, 9V rail
- Replacement for linear regulators
- Interface and microcontroller supply
- General purpose

**FEATURES**

- Peak efficiency up to 93%
- Current capability up to 1A
- 7V to 28V input voltage range
- 3.3V and 5V fixed output voltage
- Low output voltage ripple:  
typ. 15mV (3.3V) and 25mV (5Vout) at 1A load
- Short circuit protection
- Cycle by cycle current limit
- Output overvoltage protection
- Thermal shutdown
- Pulse skipping for high efficiency at light loads
- Fixed 300 kHz switching frequency
- -40°C to 85°C ambient operating temperature range
- Integrated capacitors and inductor
- RoHS & REACH compliant
- UL94V-0 package material

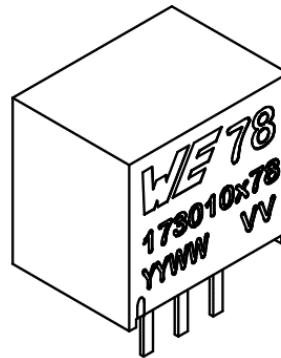

**TYPICAL CIRCUIT DIAGRAM**

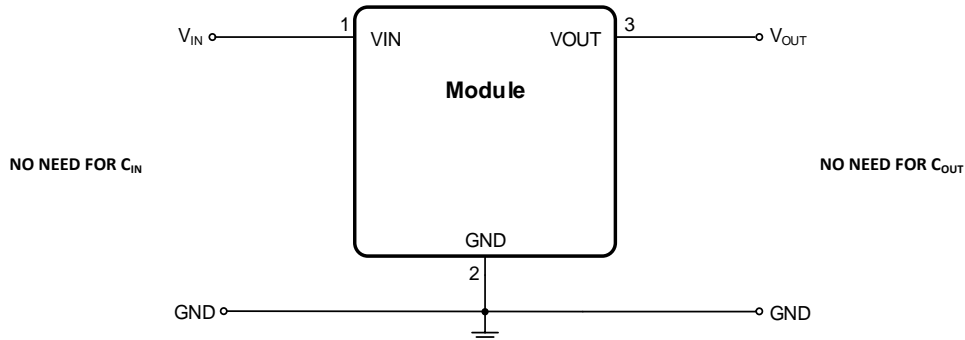

# 173010x78

## Magi<sup>3</sup>C Power Module

WPME-FDSM – Fixed Step Down Regulator Module



WÜRTH  
ELEKTRONIK  
MORE THAN  
YOU EXPECT

### PINOUT (PACKAGE TYPE F)

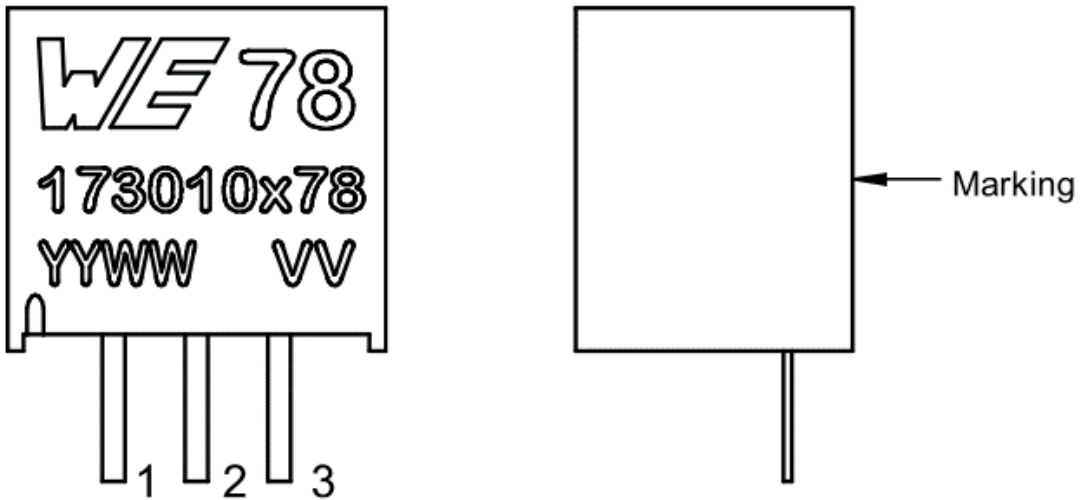

Type F package (pins are located at the front)

### MARKING DESCRIPTION

MARKING	DESCRIPTION
WE	Würth Elektronik eiSos GmbH & Co. KG
78	Indicates compatibility with 78xx linear regulator
173010x78	Order code
YY	Year
WW	Calendar week
VV	Output voltage

### PIN DESCRIPTION

SYMBOL	PIN	TYPE	DESCRIPTION
V <sub>IN</sub>	1	Power	Input voltage
GND	2	Supply	Ground, reference for V <sub>IN</sub> and V <sub>OUT</sub>
V <sub>OUT</sub>	3	Power	Output voltage.

**173010x78****MagI<sup>3</sup>C** Power Module**WPME-FDSM** – Fixed Step Down Regulator Module
**WÜRTH  
ELEKTRONIK**  
 MORE THAN  
 YOU EXPECT
**ORDERING INFORMATION**

ORDER CODE	SPECIFICATIONS	PACKAGE	PACKAGING UNIT
173010378	28V / 1A / 3.3Vout	Type F	Tube with 42 pieces
173010578	28V / 1A / 5Vout		

**PIN COMPATIBLE FAMILY MEMBERS**

ORDER CODE	SPECIFICATIONS	PACKAGE	PACKAGING UNIT
173950378	28V / 500mA / 3.3Vout	Type F	Tube with 42 pieces
173950578	28V / 500mA / 5Vout		
173010342	42V / 500mA / 3.3Vout		
173010542	42V / 500mA / 5Vout		
173950336	36V / 500mA / 3.3Vout		
173950536	36V / 500mA / 5Vout		
173951236	36V / 500mA / 12Vout		Tube with 43 pieces
173951536	36V / 500mA / 15Vout		
173010335	36V / 1A / 3.3Vout		
173010535	36V / 1A / 5Vout		
173011235	36V / 1A / 12Vout		
173011535	36V / 1A / 15Vout		
173950375	74.5V / 500mA / 3.3Vout	Type B	Tube with 43 pieces
173950575	74.5V / 500mA / 5Vout		
173951275	74.5V / 500mA / 12Vout		

**SALES INFORMATION**

SALES CONTACTS
Würth Elektronik eiSos GmbH & Co. KG EMC & Inductive Solutions Max-Eyth-Str. 1 74638 Waldenburg Germany Tel. +49 (0) 7942 945 0 www.we-online.com powermodules@we-online.com



## ABSOLUTE MAXIMUM RATINGS

Caution:

Exceeding the listed absolute maximum ratings may affect the device negatively and may cause permanent damage.

SYMBOL	PARAMETER	LIMITS		UNIT
		MIN <sup>(1)</sup>	MAX <sup>(1)</sup>	
V <sub>IN</sub>	Input voltage	-0.3	30	V
V <sub>OUT</sub>	Output voltage	-0.6	V <sub>IN</sub>	V
T <sub>STORAGE</sub>	Assembled, non-operating storage temperature	-55	125	°C

## OPERATING CONDITIONS

Operating conditions are conditions under which operation of the device is intended to be functional. All values are referenced to GND.

MIN and MAX limits are valid for the recommended ambient temperature range of **-40°C to 85°C**. Typical values represents statistically the utmost probability at following conditions: V<sub>IN</sub> = 12V, V<sub>OUT</sub> = 3.3V (173010378), V<sub>OUT</sub> = 5V (173010578), I<sub>OUT</sub> = 1A unless otherwise noted.

SYMBOL	PARAMETER	MIN <sup>(1)</sup>	TYP <sup>(2)</sup>	MAX <sup>(1)</sup>	UNIT
V <sub>IN</sub>	Input voltage (173010378)	7	-	28	V
V <sub>IN</sub>	Input voltage (173010578)	8	-	28	V
T <sub>A</sub>	Ambient temperature range	-40	-	85 <sup>(3)</sup>	°C

## THERMAL SPECIFICATIONS

SYMBOL	PARAMETER	TYP <sup>(2)</sup>	UNIT
θ <sub>JA</sub>	Junction-to-ambient thermal resistance <sup>(4)</sup>	77	°C/W
T <sub>SD</sub>	Thermal shutdown	165	°C

**ELECTRICAL SPECIFICATIONS**

MIN and MAX limits are valid for the recommended ambient temperature range of **-40°C to 85°C**. Typical values represents statistically the utmost probability at following conditions:  $V_{IN} = 12V$ ,  $V_{OUT} = 3.3V$  (173010378),  $V_{OUT} = 5V$  (173010578),  $I_{OUT} = 1A$  unless otherwise noted.

SYMBOL	PARAMETER	TEST CONDITIONS	MIN <sup>(1)</sup>	TYP <sup>(2)</sup>	MAX <sup>(1)</sup>	UNIT
<b>Output current</b>						
$I_{OCP}$	Output current protection	$V_{IN} = 12V$	2.3	3.5	-	A
<b>Accuracy</b>						
$V_{OUT}$	Line regulation	Over $V_{IN}$ range, $T_A = 25^\circ C$ , $I_{OUT} = 0A$	-	-	$\pm 1$	%
	Load regulation	Over $I_{OUT}$ range, $T_A = 25^\circ C$	-	-	$\pm 1.5$	%
	Total output voltage variation		-	$\pm 3$	$\pm 5$	%
	Output voltage ripple $5V_{OUT}$	10 $\mu$ F ceramic, 20MHz BW <sup>(5)</sup>	-	25	-	mV <sub>pp</sub>
	Output voltage ripple $3.3V_{OUT}$		-	15	-	mV <sub>pp</sub>
<b>Switching frequency</b>						
$f_{SW}$	Switching frequency	$V_{IN} = 12V$	-	300	-	kHz

<b>Input standby current</b>						
$I_Q$	Input quiescent current	Operating, non-switching	-	75	-	$\mu$ A
$I_{IN}$	No load input current	Operating, switching	-	7.5	-	mA

**173010x78**

**MagI<sup>3</sup>C** Power Module

**WPME-FDSM** – Fixed Step Down Regulator Module



**WÜRTH  
ELEKTRONIK**  
MORE THAN  
YOU EXPECT

---

**PACKAGE SPECIFICATIONS**

<b>Weight</b>	<b>Flammability</b>	<b>MTBF</b>
2.0g	Meets UL 94 V-0	MIL-HDBK 217F +25°C: 3875 <sub>10</sub> <sup>3</sup> h

**NOTES**

- (1)** Min and Max limits are 100% production tested at 25°C. Limits over the operating temperature range are guaranteed through correlation using Statistical Quality Control (SQC) methods.
- (2)** Typical numbers are valid at 25°C ambient temperature and represent statistically the utmost probability assuming the Gaussian distribution.
- (3)** Depending on load current, see derating diagram.
- (4)** Measured on a 100 x 100mm two layer board, with 35µm (1 ounce) copper, no air flow.
- (5)** The industry standard for comparison of the output voltage ripple between switching regulators or modules requires a 10µF ceramic (sometimes with an additional 1µF ceramic in parallel) at the point of load where the voltage measurement is done using an oscilloscope with its probe and probe jack for low voltage/high frequency (low impedance) measurement. The oscilloscopes bandwidth is limited at 20MHz.



TYPICAL PERFORMANCE CURVES

If not otherwise specified, the following conditions apply: T<sub>AMB</sub> = 25°C.

RADIATED EMISSIONS EN55022 (CISPR-22) CLASS B COMPLIANT

Measured on module with PCB and without external filters at 3m antenna distance

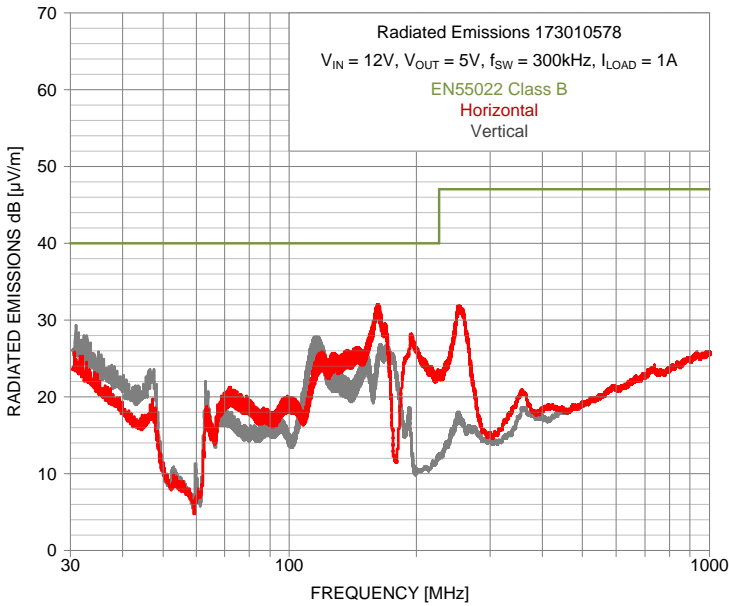

Measured on module with PCB and without external filters at 3m antenna distance

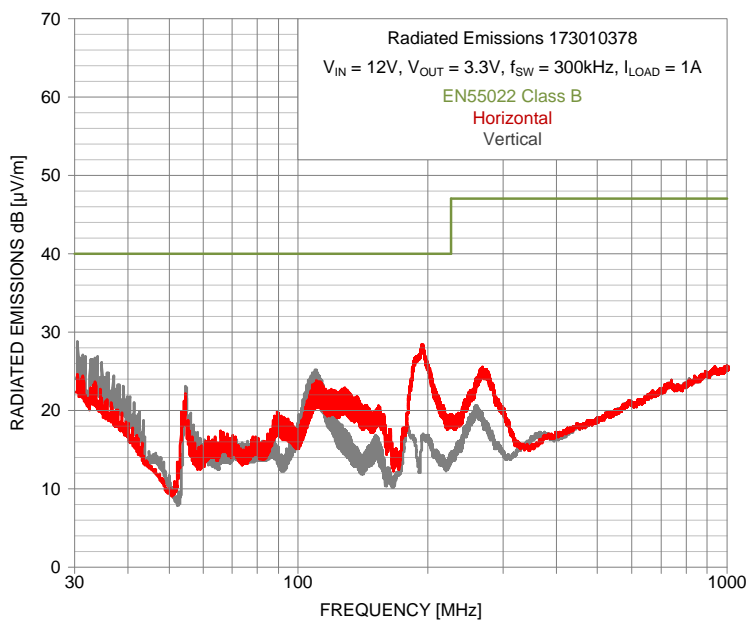



Efficiency

173010378 3.3V Output

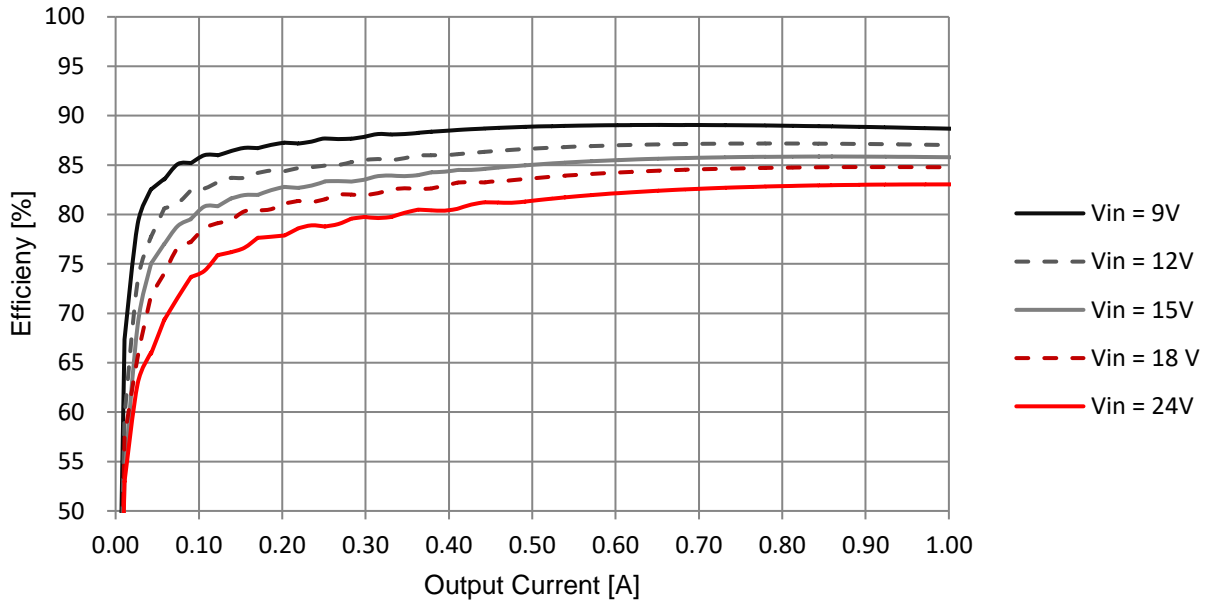

173010578 5V Output

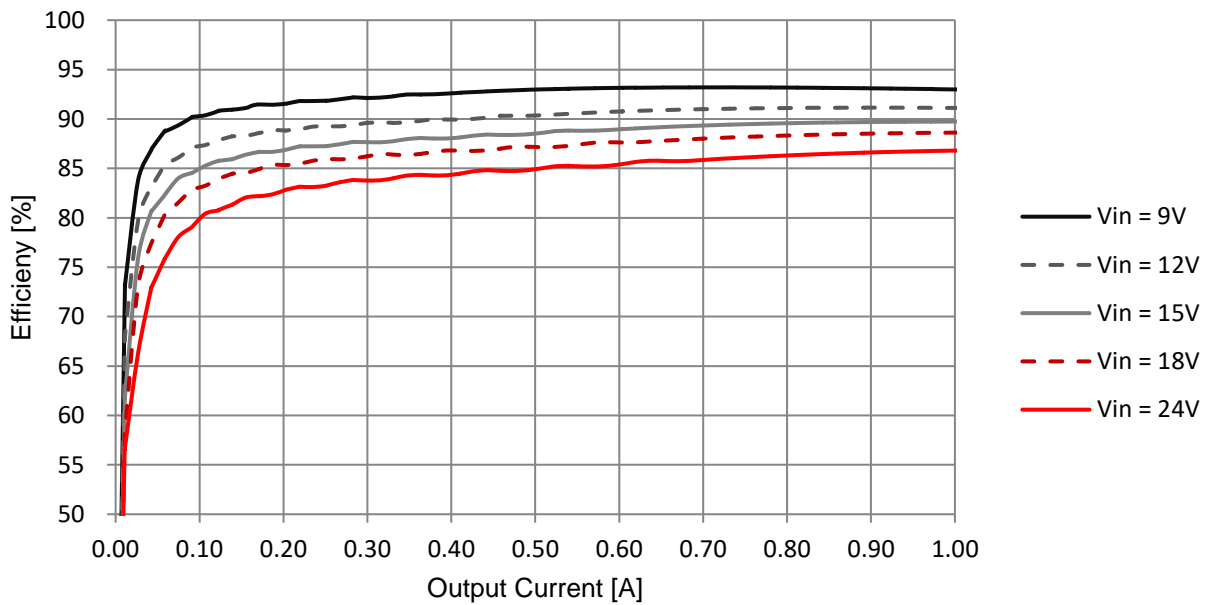

173010x78

Magi<sup>3</sup>C Power Module

WPME-FDSM – Fixed Step Down Regulator Module



WÜRTH  
ELEKTRONIK  
MORE THAN  
YOU EXPECT

OUTPUT POWER DERATING OVER TEMPERATURE

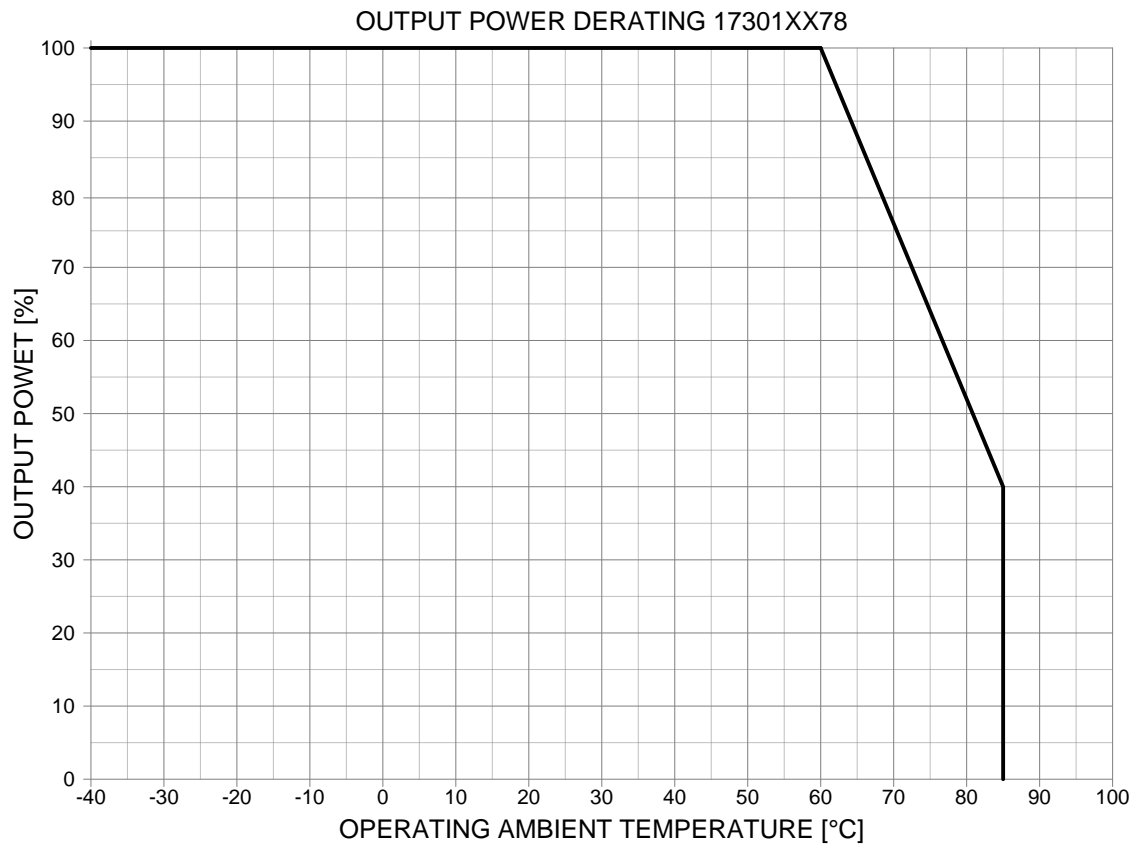

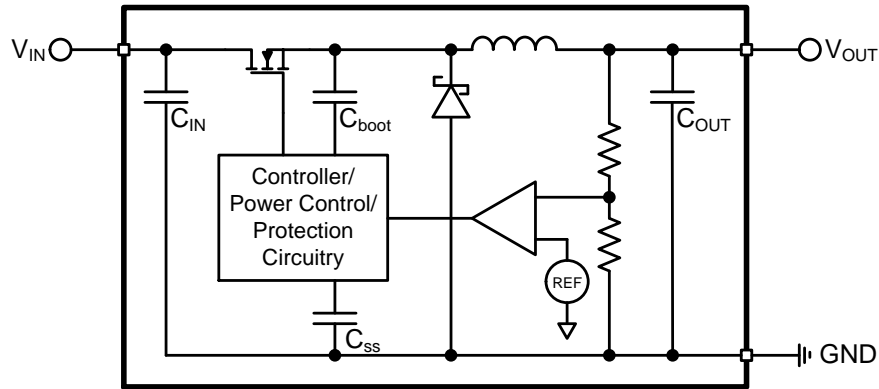
**FUNCTIONAL BLOCK DIAGRAM**

**CIRCUIT DESCRIPTION**

The MagI<sup>3</sup>C Power Module 173010x78 is based on a non-synchronous step down regulator with integrated MOSFET, free-wheeling diode, power inductor, input and output capacitors. The control scheme is based on a Current Mode (CM) regulation loop.

The  $V_{OUT}$  of the regulator is divided with the internal feedback resistor network and fed into the error amplifier, which compares this signal with the internal 0.8V reference. The error signal is amplified and controls the on-time of a fixed frequency pulse with generator. This signal drives the power MOSFET.

The Current Mode architecture features a constant frequency during load steps. Only the on-time is modulated. It is internally compensated and stable with low ESR output capacitors and requires no external compensation network.

**173010x78**

**MagI<sup>3</sup>C** Power Module

**WPME-FDSM** – Fixed Step Down Regulator Module



**WÜRTH  
ELEKTRONIK**  
MORE THAN  
YOU EXPECT

---

## PROTECTIVE FEATURES

### Over temperature protection (OTP)

The junction temperature of the MagI<sup>3</sup>C power module should not be allowed to exceed its maximum ratings. Thermal protection is implemented by an internal Thermal Shutdown circuit which activates at 165 °C (typ) causing the device to enter a low power standby state. In this state the MOSFET remains off causing  $V_{OUT}$  to fall. Thermal protection helps prevent catastrophic failures for accidental device overheating. When the junction temperature falls back below 165 °C,  $V_{OUT}$  rises smoothly, and normal operation resumes.

### Over current protection (OCP)

For protection against load faults, the MagI<sup>3</sup>C Power Module incorporates cycle-by-cycle current limiting. During an overcurrent condition the output current is limited and the output voltage is reduced. When the overcurrent condition is removed, the output voltage returns to the established voltage. For output voltages below 0.6V the switching frequency is reduced by several steps.

### Output overvoltage protection (OVP)

When the output voltage goes above approx. 109% of the specified output voltage the high side MOSFET will be forced off until the output voltage falls below approx. 107% of specified output.

### Short circuit protection (SCP)

The short circuit protection is realized via the cycle by cycle current limiting. The short circuit protection is indefinite with a recovery at the following switching cycle if the short circuit condition is removed.

# 173010x78

## MagI<sup>3</sup>C Power Module

WPME-FDSM – Fixed Step Down Regulator Module



WÜRTH  
ELEKTRONIK  
MORE THAN  
YOU EXPECT

### PHYSICAL DIMENSIONS

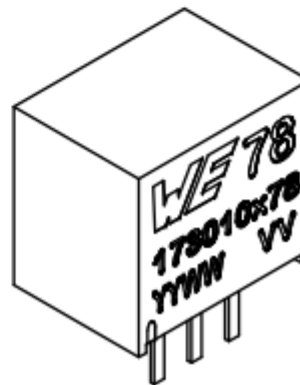
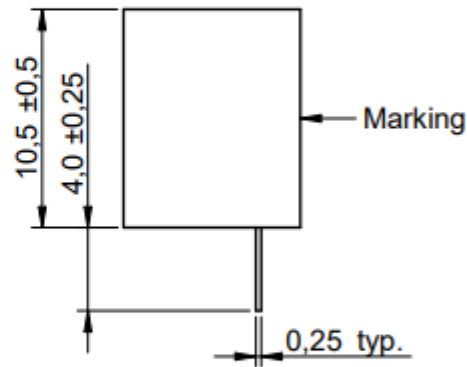
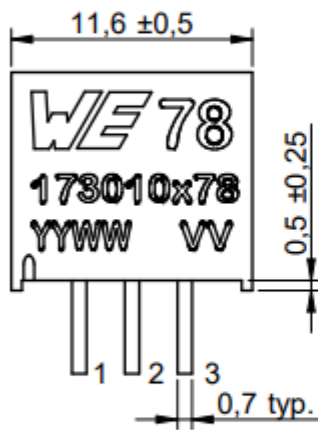
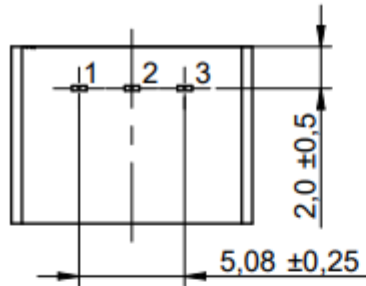

173010x78

MagI<sup>3</sup>C Power Module

WPME-FDSM – Fixed Step Down Regulator Module



WÜRTH  
ELEKTRONIK  
MORE THAN  
YOU EXPECT

RECOMMENDED DRILL HOLES

TUBE

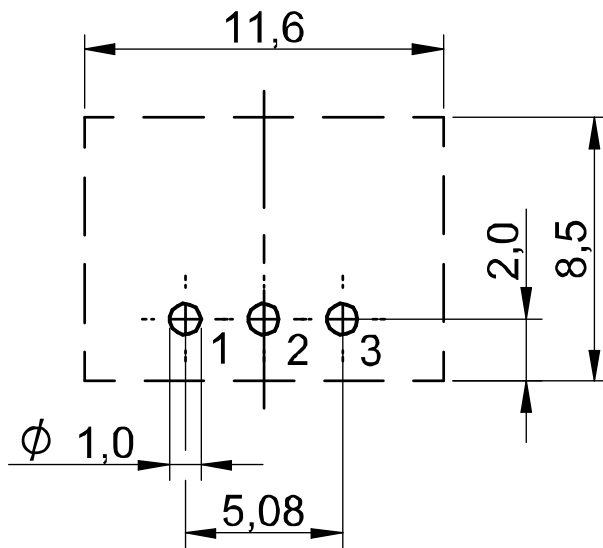

All dimensions in mm

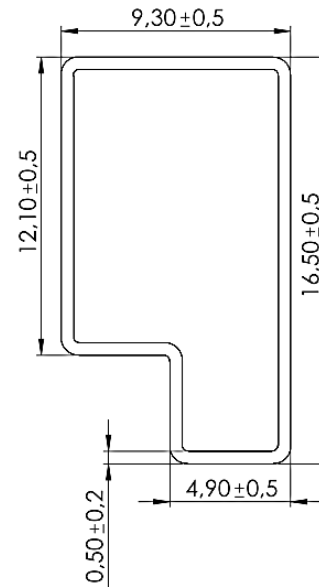

173010x78

MagI<sup>3</sup>C Power Module

WPME-FDSM – Fixed Step Down Regulator Module



WÜRTH  
ELEKTRONIK  
MORE THAN  
YOU EXPECT

## DOCUMENT HISTORY

Revision	Date	Description	Comment
1.0	11.01.2015	Final version	
2.0	May 2020	PCN	<ol style="list-style-type: none"><li>1. Updated front page drawing. (page 1)</li><li>2. Updated pinout drawing to include pin 1 marking. (page 2)</li><li>3. Updated physical dimensions drawings to include pin 1 marking. (page 37)</li><li>4. Updated recommended drill holes. (page 10)</li></ol>

173010x78

MagI<sup>3</sup>C Power Module

WPME-FDSM – Fixed Step Down Regulator Module



WÜRTH  
ELEKTRONIK  
MORE THAN  
YOU EXPECT

---

## CAUTIONS AND WARNINGS

The following conditions apply to all goods within the product series of MagI<sup>3</sup>C Power Modules of Würth Elektronik eiSos GmbH & Co. KG:

### General:

- This electronic component is designed and manufactured for use in general electronic equipment.
- Würth Elektronik must be asked for written approval (following the PPAP procedure) before incorporating the components into any equipment in fields such as military, aerospace, aviation, nuclear control, submarine, transportation (automotive control, train control, ship control), transportation signal, disaster prevention, medical, public information network, etc. where higher safety and reliability are especially required and/or if there is the possibility of direct damage or human injury.
- Electronic components that will be used in safety-critical or high-reliability applications, should be pre-evaluated by the customer.
- The component is designed and manufactured to be used within the datasheet specified values. If the usage and operation conditions specified in the datasheet are not met, the component may be damaged or dissolved.
- Do not drop or impact the components as material of the body, pins or termination may flake apart.
- Würth Elektronik products are qualified according to international standards, which are listed in each product reliability report. Würth Elektronik does not warrant any customer qualified product characteristics beyond Würth Elektronik's specifications, for its validity and sustainability over time.
- All technical specifications for standard products also apply to customer specific products.
- Customer acknowledges and agrees that it is solely responsible for compliance with all legal, regulatory and safety-related requirements concerning its products, and any use of Würth Elektronik eiSos GmbH & Co. KG components in its applications, notwithstanding any applications-related information or support that may be provided by Würth Elektronik eiSos GmbH & Co. KG. Customer represents and agrees that it has all the necessary expertise to create and implement safeguards which anticipate dangerous consequences of failures, monitor failures and their consequences lessen the likelihood of failures that might cause harm and take appropriate remedial actions. Customer will fully indemnify Würth Elektronik eiSos and its representatives against any damages arising out of the use of any Würth Elektronik eiSos GmbH & Co. KG components in safety-critical applications.

### Product specific:

#### Soldering:

- The solder profile must comply with the technical product specifications. All other profiles will void the warranty.
- All other soldering methods are at the customer's own risk.

#### Cleaning and Washing:

- Residual washing varnish agent that is used during the production to clean the application might change the characteristics of the body, pins or termination. The washing varnish agent may have a negative effect on the long term function of the component.



- Using a brush during the cleaning process may break the component. Therefore, we do not recommend using a brush during the PCB cleaning process.

**Potting and Coating:**

- If the component is potted in the customer application, the potting material might shrink or expand during and after hardening. Shrinking could lead to an incomplete seal, allowing contaminants into the component. Expansion could damage the components or parts of it. We recommend a manual inspection after potting to avoid these effects.
- Conformal coating may affect the product performance.

**Storage Conditions:**

- A storage of Würth Elektronik products for longer than 12 months is not recommended. Within other effects, the terminals may suffer degradation, resulting in bad solderability. Therefore, all products shall be used within the period of 12 months based on the day of shipment.
- Do not expose the components to direct sunlight.
- The storage conditions in the original packaging are defined according to DIN EN 61760-2.
- For a moisture sensitive component, the storage condition in the original packaging is defined according to IPC/JEDEC-J-STD-033. It is also recommended to return the component to the original moisture proof bag and reseal the moisture proof bag again.
- ESD prevention methods need to be followed for manual handling and processing by machinery.
- The storage conditions stated in the original packaging apply to the storage time and not to the transportation time of the components.

**Packaging:**

- The packaging specifications apply only to purchase orders comprising whole packaging units. If the ordered quantity exceeds or is lower than the specified packaging unit, packaging in accordance with the packaging specifications cannot be ensured.

**Handling:**

- Violation of the technical product specifications such as exceeding the absolute maximum ratings will void the warranty and also the conformance to regulatory requirements.
- The edge castellation is designed and made for prototyping, i.e. hand soldering purposes, only.
- The applicable country regulations and specific environmental regulations must be observed.
- Do not disassemble the component. Evidence of tampering will void the warranty.
- The temperature rise of the component must be taken into consideration. The operating temperature is comprised of ambient temperature and temperature rise of the component.  
The operating temperature of the component shall not exceed the maximum temperature specified.
- Direct mechanical impact to the component must be prevented as the material of the body, pins or termination could flake or, in the worst case, could break. As these devices are sensitive to electrostatic discharge, proper IC Handling Procedures must be followed.

These cautions and warnings comply with the state of the scientific and technical knowledge and are believed to be accurate and reliable. However, no responsibility is assumed for inaccuracies or incompleteness.



---

## IMPORTANT NOTES

### General Customer Responsibility

Some goods within the product range of Würth Elektronik eiSos GmbH & Co. KG contain statements regarding general suitability for certain application areas. These statements about suitability are based on our knowledge and experience of typical requirements concerning the areas, serve as general guidance and cannot be estimated as binding statements about the suitability for a customer application. The responsibility for the applicability and use in a particular customer design is always solely within the authority of the customer. Due to this fact it is up to the customer to evaluate, where appropriate to investigate and decide whether the device with the specific product characteristics described in the product specification is valid and suitable for the respective customer application or not. Accordingly, the customer is cautioned to verify that the datasheet is current before placing orders.

### Customer Responsibility Related to Specific, in Particular Safety-Relevant, Applications

It has to be clearly pointed out that the possibility of a malfunction of electronic components or failure before the end of the usual lifetime cannot be completely eliminated in the current state of the art, even if the products are operated within the range of the specifications. In certain customer applications requiring a very high level of safety and especially in customer applications in which the malfunction or failure of an electronic component could endanger human life or health it must be ensured by most advanced technological aid of suitable design of the customer application that no injury or damage is caused to third parties in the event of malfunction or failure of an electronic component.

### Best Care and Attention

Any product-specific notes, warnings and cautions must be strictly observed. Any disregard will result in the loss of warranty.

### Customer Support for Product Specifications

Some products within the product range may contain substances which are subject to restrictions in certain jurisdictions in order to serve specific technical requirements. Necessary information is available on request. In this case the field sales engineer or the internal sales person in charge should be contacted who will be happy to support in this matter.

### Product R&D

Due to constant product improvement product specifications may change from time to time. As a standard reporting procedure of the Product Change Notification (PCN) according to the JEDEC-Standard we inform about minor and major changes. In case of further queries regarding the PCN, the field sales engineer or the internal sales person in charge should be contacted. The basic responsibility of the customer as per Section 1 and 2 remains unaffected.

### Product Life Cycle

Due to technical progress and economical evaluation we also reserve the right to discontinue production and delivery of products. As a standard reporting procedure of the Product Termination Notification (PTN) according to the JEDEC-Standard we will inform at an early stage about inevitable product discontinuance. According to this we cannot guarantee that all products within our product range will always be available. Therefore it needs to be verified with the field sales engineer or the internal sales person in charge about the current product availability expectancy before or when the product for application design-in disposal is considered. The approach named above does not apply in the case of individual agreements deviating from the foregoing for customer-specific products.

**173010x78**

**MagI<sup>3</sup>C** Power Module

**WPME-FDSM** – Fixed Step Down Regulator Module



**WÜRTH  
ELEKTRONIK**  
MORE THAN  
YOU EXPECT

---

#### **Property Rights**



All the rights for contractual products produced by Würth Elektronik eiSos GmbH & Co. KG on the basis of ideas, development contracts as well as models or templates that are subject to copyright, patent or commercial protection supplied to the customer will remain with Würth Elektronik eiSos GmbH & Co. KG. Würth Elektronik eiSos GmbH & Co. KG does not warrant or represent that any license, either expressed or implied, is granted under any patent right, copyright, mask work right, or other intellectual property right relating to any combination, application, or process in which Würth Elektronik eiSos GmbH & Co. KG components or services are used.

#### **General Terms and Conditions**

Unless otherwise agreed in individual contracts, all orders are subject to the current version of the "General Terms and Conditions of Würth Elektronik eiSos Group", last version available at [www.we-online.com](http://www.we-online.com).

## Looking for pricing, stock, or lifecycle information?

Click below to explore more details on WIN SOURCE:

-  [View 173010378 on WIN SOURCE](#)
-  [Wurth Electronics Inc Information](#)

## Optimize Your Supply Chain with WIN SOURCE Solutions

-  Global Sourcing Solution
-  Obsolete Management
-  Cost Control Management
-  Shortage Management
-  Alternative Solution
-  Excess Inventory Management