



**THE DATASHEET OF
171010550**



2.5V - 5.5V Input / 1.2A Output / 0.8V - 5.5V Output

DESCRIPTION

The VDMM 171010550 MagI³C MicroModule provides a fully integrated DC-DC power supply including the switching regulator IC with integrated MOSFETs, controller, compensation and shielded inductor in one package.

The 171010550 offers high efficiency and delivers up to 1.2A of output current. It operates with an input voltage from 2.5V to 5.5V and is designed for a small solution size.

The selectable forced COT or power save mode allows for the choice between high efficiency and low output voltage ripple at light load.

The 171010550 is available in an LGA-6EP package (2.5 x 2.5 x 1.2mm).

This module has integrated protection circuitry that guards against thermal overstress with thermal shutdown and protects against electrical damage using overcurrent, short-circuit and undervoltage protections.

FEATURES

- Peak efficiency up to 96%
- Current capability up to 1.2A
- Input voltage range: 2.5V to 5.5V
- Output voltage range: 0.8V to 5.5V
- 25µA typical quiescent current
- Integrated shielded inductor
- Low output voltage ripple: ±6mV typ.
- Output voltage accuracy over temperature: 2% max
- Fixed switching frequency: 4MHz
- Constant on-time control
- Synchronous operation
- Selectable forced COT or power save mode
- Undervoltage lockout
- Internal soft-start
- Thermal shutdown
- Short-circuit protection
- Cycle-by-cycle current limit
- RoHS und REACH compliant
- Operating ambient temperature up to 85°C
- Operating junction temp. range: -40°C to 125°C
- Complies with EN55032 class B radiated emissions standard

TYPICAL APPLICATIONS

- General point of load power supply for low power systems
- Replacement of linear regulators
- DSP and FPGA power supply auxiliary voltages
- Portable instruments
- Battery powered equipment

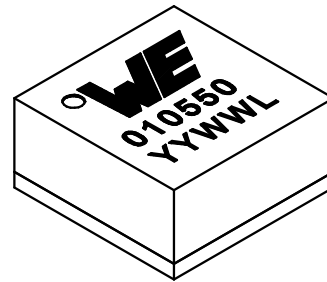

TYPICAL CIRCUIT DIAGRAM

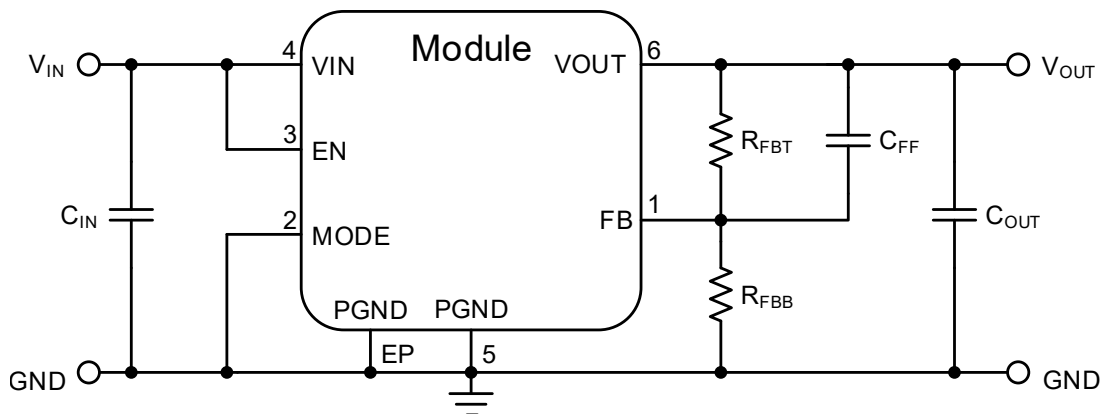

PINOUT

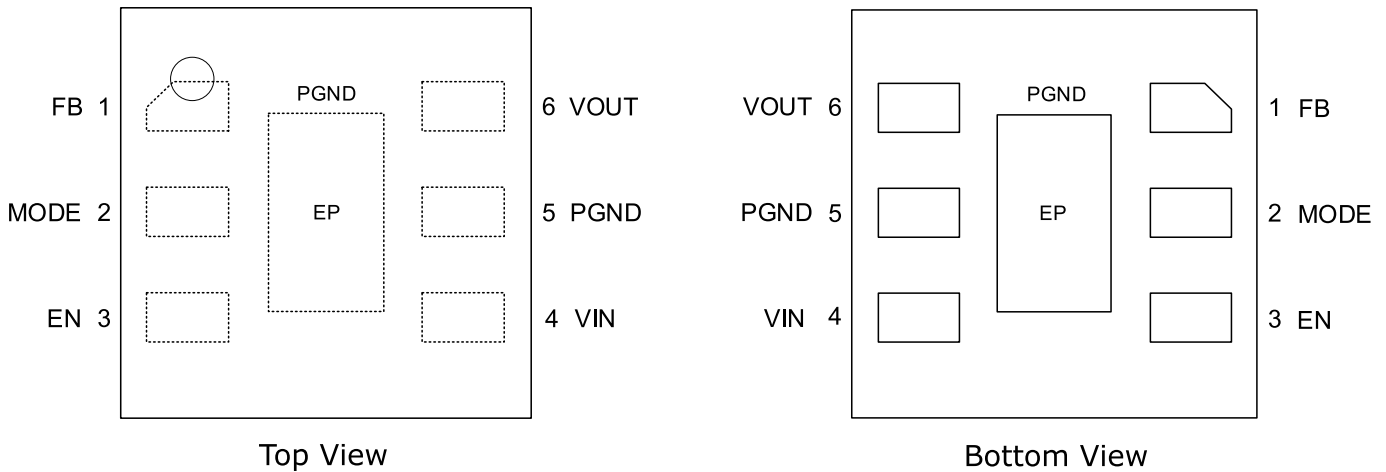

Figure 1: Pinout

MARKING	DESCRIPTION
°WE	Pin 1 Indicator and Logo
010550	Order Code
XXYYZ	Year, Week and Lot Number

SYMBOL	NUMBER	TYPE	DESCRIPTION
FB	1	Input	Feedback pin. This pin must be connected to the external resistor divider (between VOUT and PGND) to adjust the output voltage.
MODE	2	Input	Forced COT or power save mode selection pin. Settings this pin high, the forced PWM mode is selected for every load current. Settings this pin low, PFM/PWM is selected, with the transition automatically occurring between the two operating modes according to the load. This pin must not be left floating.
EN	3	Input	Enable pin. Setting this pin high enables the device, while setting this pin low shuts down the device. This pin must not be left floating.
VIN	4	Power	Input voltage. Place the input capacitor as close as possible to VIN and PGND.
PGND	5	Power	Power ground. It must be connected to the ground plane and to the exposed pad.
VOUT	6	Power	Output voltage. Place output capacitors as close as possible to VOUT and PGND. For thermal performance, use copper plane(s) at this pin.
PGND	EP	Exposed Pad	Exposed pad. This pin is internally electrically connected to PGND. It is recommended to connect it to the ground plane for device heat dissipation.

171010550

MagI³C Power Module

VDMM - Variable Step Down MicroModule



**WÜRTH
ELEKTRONIK**
MORE THAN
YOU EXPECT

ORDERING INFORMATION

ORDER CODE	SPECIFICATIONS	PACKAGE	PACKAGING UNIT
171010550	1.2A / 0.8V-5.5V Vout version	LGA-6EP	7" Reel (1000 pieces)
178010550	1.2A / 0.8V-5.5V Vout version	Eval Board	Box with 1 piece

SALES INFORMATION

SALES CONTACT
Würth Elektronik eiSos GmbH & Co. KG EMC and Inductive Solutions Max-Eyth-Str. 1 74638 Waldenburg Germany Tel. +49 (0) 7942 945 0 www.we-online.com/powermodules Technical support: powermodules@we-online.com

ABSOLUTE MAXIMUM RATINGS

Caution:

Exceeding the listed absolute maximum ratings may affect the device negatively and may cause permanent damage.

SYMBOL	PARAMETER	LIMIT		UNIT
		MIN ⁽¹⁾	MAX ⁽¹⁾	
V _{IN}	Input Voltage	-0.3	6	V
V _{OUT}	Output Voltage	-0.3	V _{IN} +0.3	V
FB	Feedback	-0.3	V _{IN} +0.3	V
EN	Enable	-0.3	V _{IN} +0.3	V
MODE	Mode Select	-0.3	V _{IN} +0.3	V
T _{storage}	Assembled, non-operating storage temperature	-40	85	°C
V _{esd}	ESD Voltage (HBM), all pins (C=100pF, R=1.5kΩ)	-4	4	kV

OPERATING CONDITIONS

Operating conditions are conditions under which the device is intended to be functional. All values are referenced to GND.

MIN and MAX limits are valid for the recommended ambient temperature range of -40°C to 85°C.

SYMBOL	PARAMETER	MIN ⁽¹⁾	TYP ⁽³⁾	MAX ⁽¹⁾	UNIT
V _{IN}	Input Voltage	2.5	-	5.5	V
V _{OUT}	Output Voltage	0.8	-	5.5	V
T _a	Ambient temperature range	-40	-	85 ⁽²⁾	°C
T _{jop}	Junction temperature range	-40	-	125	°C
I _{out}	Nominal output current	-	-	1.2	A

THERMAL SPECIFICATIONS

Caution:

Exceeding the listed absolute maximum ratings may affect the device negatively and may cause permanent damage.

SYMBOL	PARAMETER	TYP ⁽³⁾	UNIT
Θ _{JA}	Junction-to-ambient thermal resistance ⁽⁴⁾	150	K/W
Θ _{JC}	Junction-to-case (top) thermal resistance ⁽⁴⁾	82	K/W
T _{SD}	Thermal shutdown, rising	160	°C
	Thermal shutdown, hysteresis	10	°C

ELECTRICAL SPECIFICATIONS

Caution:

MIN and MAX limits are valid for the recommended ambient temperature range of -40°C to 85°C. Typical values represents statistically the utmost probable values at the following conditions: $V_{IN} = 5V$, $V_{OUT} = 1.8V$, $C_{IN} = 4.7\mu F$ ceramic, $C_{OUT} = 10\mu F$ ceramic, $T_A = 25^\circ C$ unless otherwise noted.

SYMBOL	PARAMETER	TEST CONDITIONS	MIN ⁽¹⁾	TYP ⁽³⁾	MAX ⁽¹⁾	UNIT
Output Current						
I_{OCP}	Overcurrent protection		1.5	2.3	3.0	A
Output Voltage						
V_{FB}	Reference voltage	$-40^\circ C \leq T_A \leq 85^\circ C$	0.784	0.8	0.816	V
I_{FB}	Feedback input bias current		-	0	50	nA
V_{OUT}	Line regulation	$V_{IN} = V_{OUT} + 1V$ to 5.5V, MODE = low	-	0.04	0.2	%/V
	Load regulation	$500mA \leq I_{LOAD} \leq 1A$	-	-0.9	-	%/A
	Output voltage ripple	$V_{IN} = 3.6V$, $I_{OUT} = 100mA$, MODE = high, 20MHz BWL ⁽⁵⁾	-	6	-	mV _{pp}
		$V_{IN} = 3.6V$, $I_{OUT} = 100mA$, MODE = low, 20MHz BWL ⁽⁵⁾	-	65	-	mV _{pp}
Switching Frequency						
f_{SW}	Switching frequency		3.6	4	4.4	MHz
Enable and Undervoltage Lockout						
V_{UVLO}	V_{IN} undervoltage threshold	V_{IN} increasing	2	2.25	2.4	V
		V_{IN} decreasing	-	2	-	V
	V_{IN} undervoltage hysteresis		-	175	-	mV
V_{EN}	EN threshold	Enable logic high	-	0.85	-	V
		Enable logic low	-	0.75	-	V
I_{EN}	EN pin input current	Enable = high	-	0.1	-	μA
		Enable = low	-	0.1	-	μA
Mode Selection						
V_{MODE}	MODE threshold	MODE logic high	-	0.85	-	V
		MODE logic low	-	0.75	-	V
I_{MODE}	MODE input current	MODE = high	-	0.1	-	μA
		MODE = low	-	0.1	-	μA
Soft-Start						
t_{SS}	Soft-start time	$T_A = 25^\circ C$ (rising edge to 95% of V_{OUT})	-	128	-	μs

Caution:

MIN and MAX limits are valid for the recommended ambient temperature range of -40°C to 85°C. Typical values represents statistically the utmost probable values at the following conditions: $V_{IN} = 5V$, $V_{OUT} = 1.8V$, $C_{IN} = 4.7\mu F$ ceramic, $C_{OUT} = 10\mu F$ ceramic, $T_A = 25^\circ C$ unless otherwise noted.

SYMBOL	PARAMETER	TEST CONDITIONS	MIN ⁽¹⁾	TYP ⁽³⁾	MAX ⁽¹⁾	UNIT
Efficiency						
η	Efficiency	$V_{IN} = 3.6V$, $V_{OUT} = 1.8V$, $I_{OUT} = 50mA$, MODE = low	-	87	-	%
		$V_{IN} = 5V$, $V_{OUT} = 3.3V$, $I_{OUT} = 50mA$, MODE = low	-	90	-	%
		$V_{IN} = 3.6V$, $V_{OUT} = 1.8V$, $I_{OUT} = 200mA$, MODE = high	-	88	-	%
		$V_{IN} = 5V$, $V_{OUT} = 3.3V$, $I_{OUT} = 200mA$, MODE = high	-	90	-	%
		$V_{IN} = 3.6V$, $V_{OUT} = 3.3V$, $I_{OUT} = 200mA$, MODE = low	-	96	-	%
Input Quiescent and Shutdown Current						
I_{SD}	Shutdown current	$V_{EN} = \text{low}$, $V_{IN} = 5V$	-	0.1	-	μA
		$V_{EN} = \text{low}$, $V_{IN} = 2.5V$	-	0.09	-	μA
I_{IN}	No load input current	MODE = high, Enable = high, switching with no load	-	13	-	mA
		MODE = high, Enable = high, switching with no load	-	25	-	μA
I_Q	Quiescent current	MODE = high, Enable = high, no switching, $V_{IN} = 2.5V$	-	25	-	μA
		MODE = high, Enable = high, no switching	-	25	-	μA
Output Capacitance						
C_{OUT_MAX}	Maximum output capacitance		-	220	-	μF

RoHS, REACH

RoHS directive		Directive 2011/65/EU of the European Parliament and the Council of June 8th, 2011 on the restriction of the use of certain hazardous substances in electrical and electronic equipment.
REACH directive		Directive 1907/2006/EU of the European Parliament and the Council of June 1st, 2007 regarding the Registration, Evaluation, Authorization and Restriction of Chemicals (REACH).

PACKAGE SPECIFICATIONS

ITEM	PARAMETER	TYP ⁽³⁾	UNIT
Mold Compound	UL94V-0	-	-
Weight	-	0.0204	g

NOTES

- (1) Min and Max limits are 100% production tested at 25°C. Limits over the operating temperature range are guaranteed through correlation using Statistical Quality Control (SQC) methods.
- (2) Depending on heat sink design, number of PCB layers, copper thickness and air flow.
- (3) Typical numbers are valid at 25°C ambient temperature and represent statistically the utmost probable values assuming a Gaussian distribution.
- (4) Measured on the 178010550 evaluation board, a 40 x 40mm two layer board, with 35µm (1 ounce) copper.
- (5) The industry standard for comparison of the output voltage ripple between switching regulators or modules requires a 10µF ceramic (sometimes additional 1µF ceramic in parallel) at the point of load where the voltage measurement is done using an oscilloscope with its probe and probe jack designed for low voltage/high frequency (low impedance) measurement. The oscilloscopes bandwidth is limited at 20MHz.

TYPICAL PERFORMANCE CURVES

If not otherwise specified, the following conditions apply: $V_{IN} = 5V$, $C_{IN} = 4.7\mu F$ X5R ceramic, $C_{OUT} = 10\mu F$ X5R ceramic, $C_{FF} = 22pF$, $T_{AMB} = 25^{\circ}C$.

RADIATED EMISSIONS EN55032 (CISPR-32) CLASS B COMPLIANT

Measured with module on an Evaluation Board 178010550 in a Fully Anechoic Room (FAR) at 3m antenna distance.

TEST SETUP

Input wire length:

- Radiated Emission: 160cm (80cm Horizontal + 80cm Vertical)

Output wire length:

- Short wire (with input filter): Load directly on evaluation board
- Long wire (with input filter): 1m

RADIATED BEHAVIOR (without input filter)

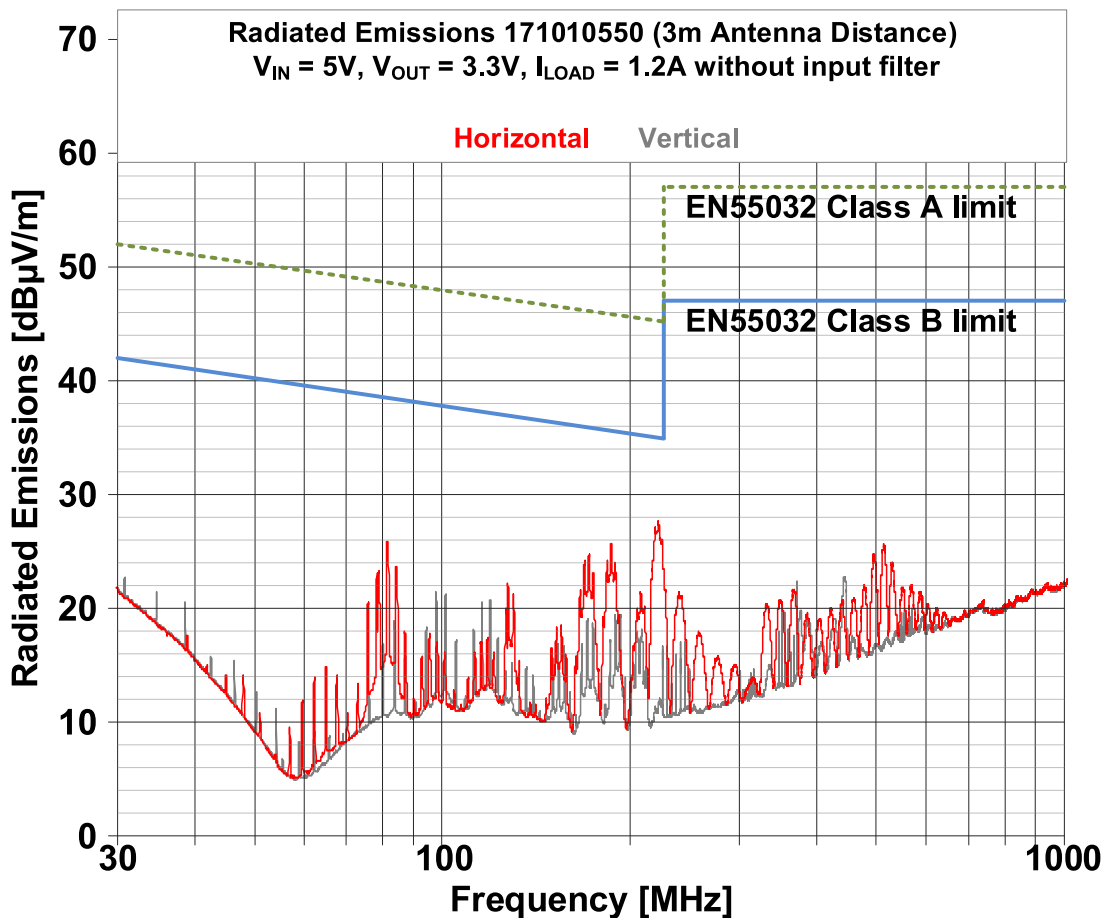

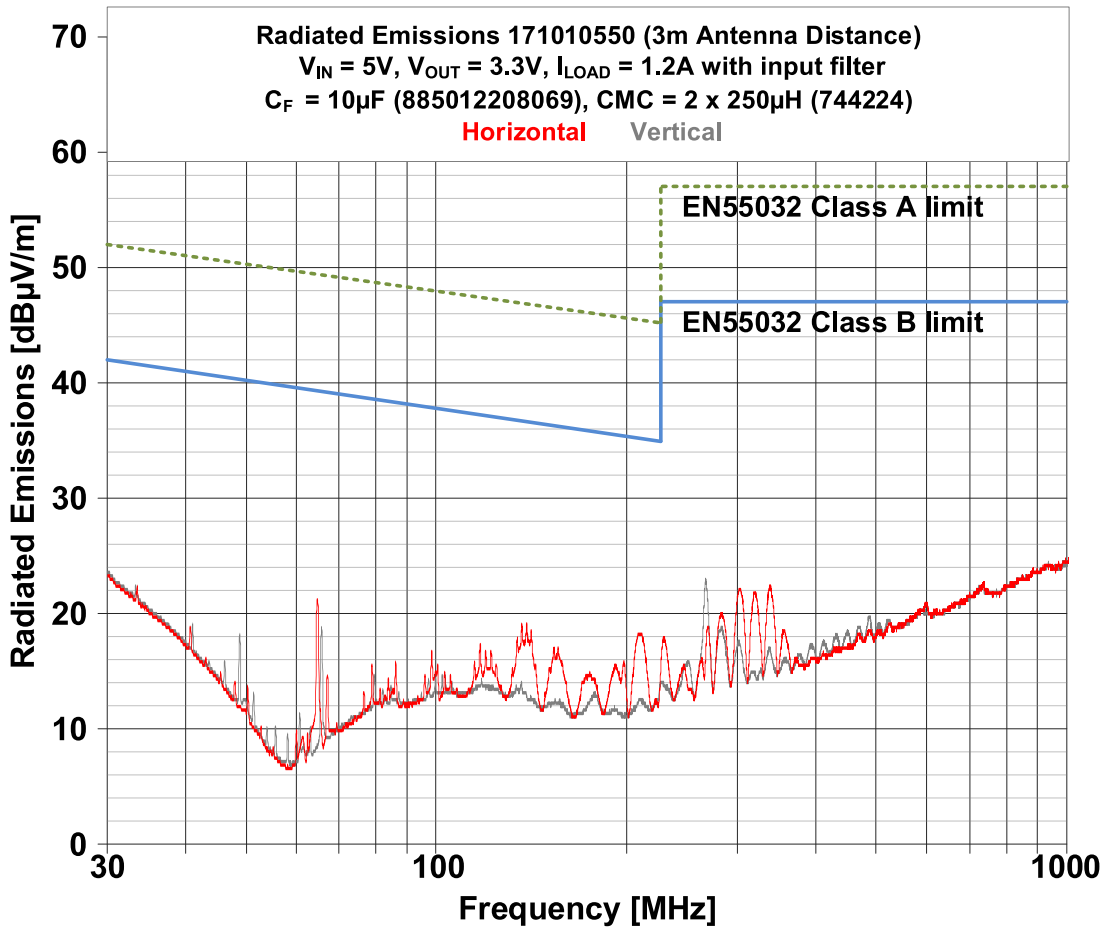
RADIATED BEHAVIOR (with input filter)

The diagram above refers only to forced COT mode. Nevertheless, similar results would be obtained in power save mode because at this load current (1.2A) there is no difference between the two modes.

EFFICIENCY 5V_{in} POWER SAVE

171010550 V_{IN} = 5V, Power Save Mode, T_A = 25°C

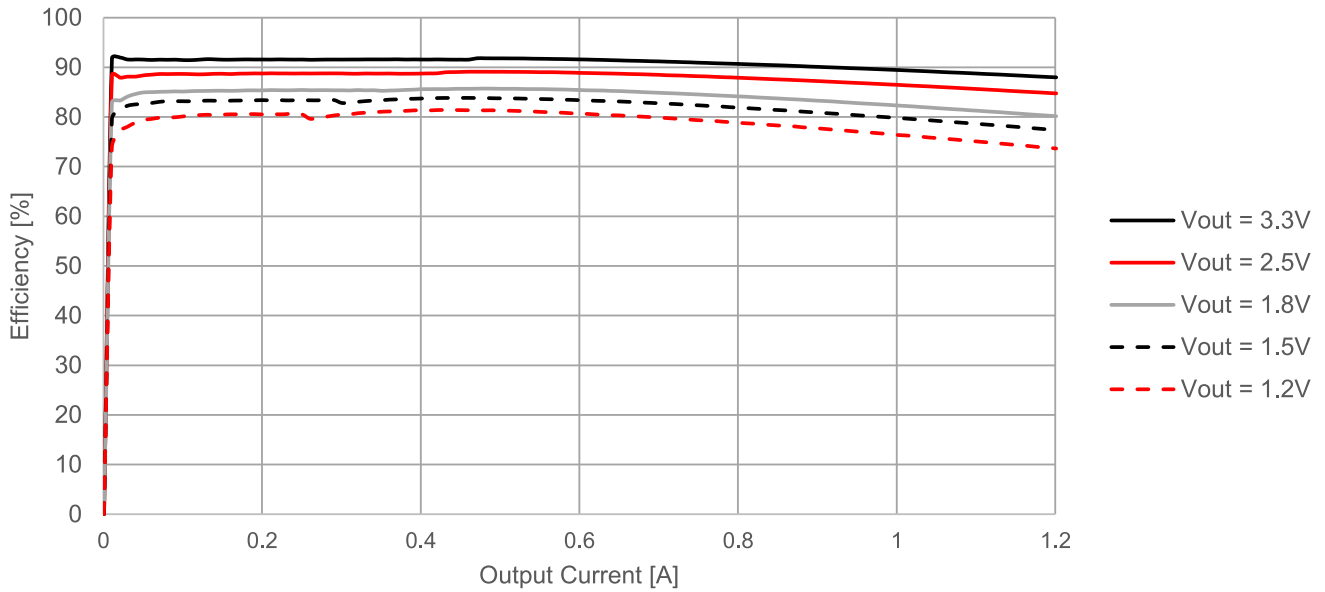

171010550 V_{IN} = 5V, Power Save Mode, T_A = 85°C

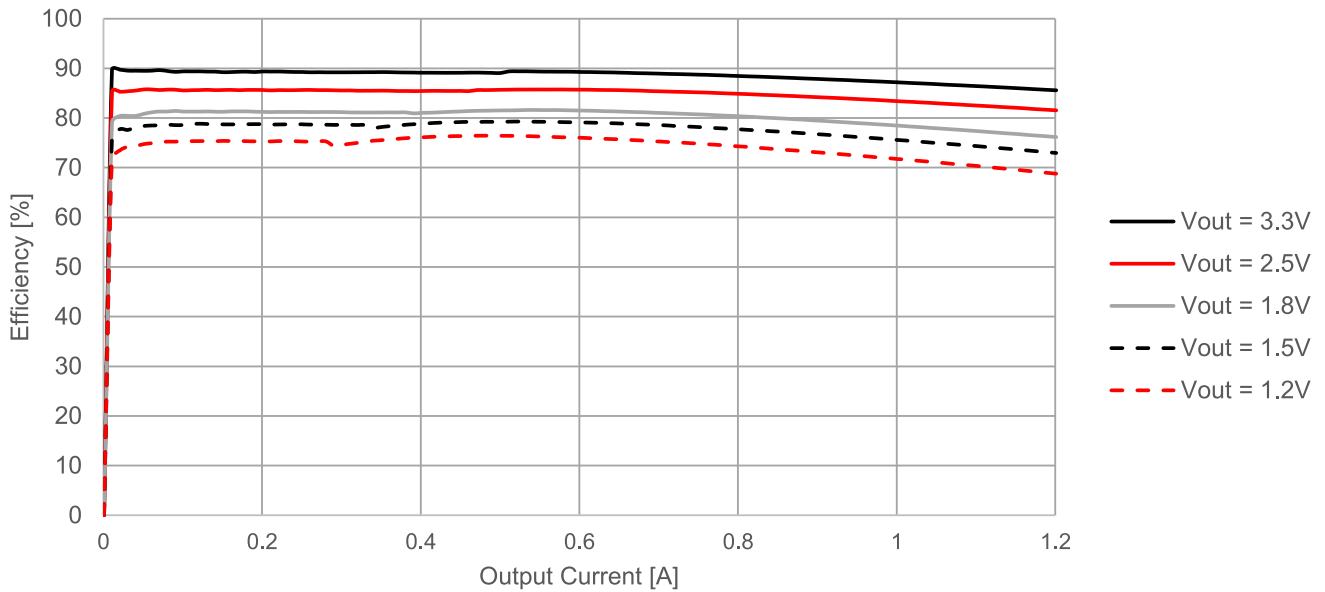

EFFICIENCY 3.6Vin POWER SAVE

171010550 $V_{IN} = 3.6V$, Power Save Mode, $T_A = 25^\circ C$

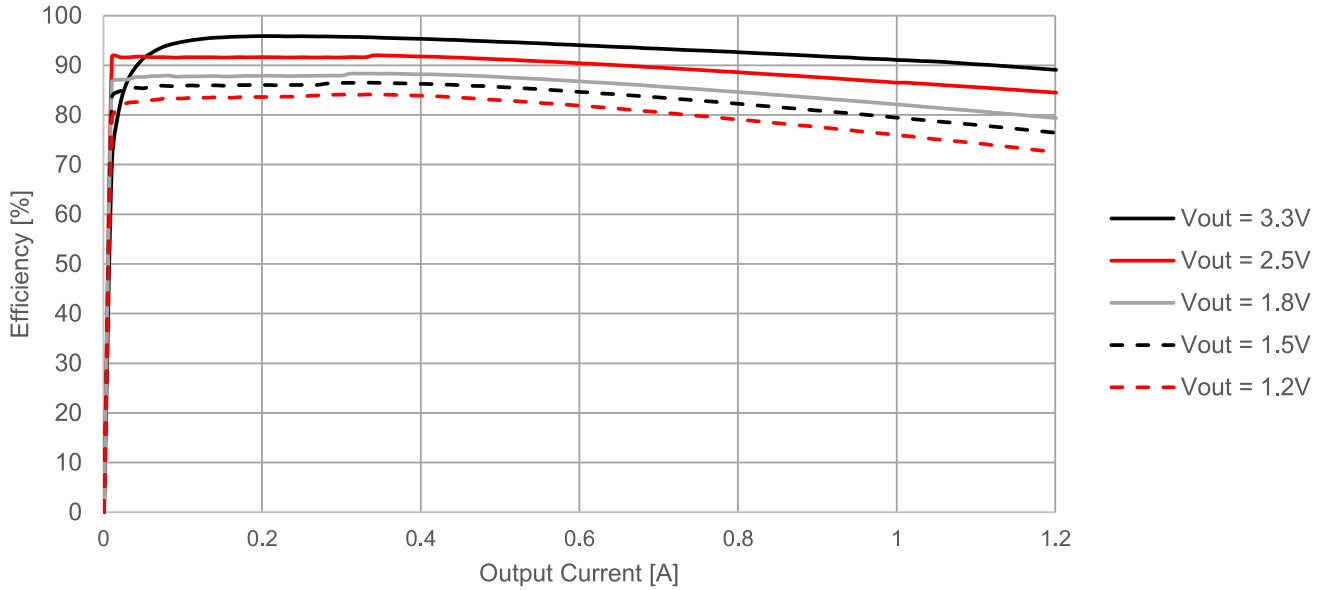

171010550 $V_{IN} = 3.6V$, Power Save Mode, $T_A = 85^\circ C$

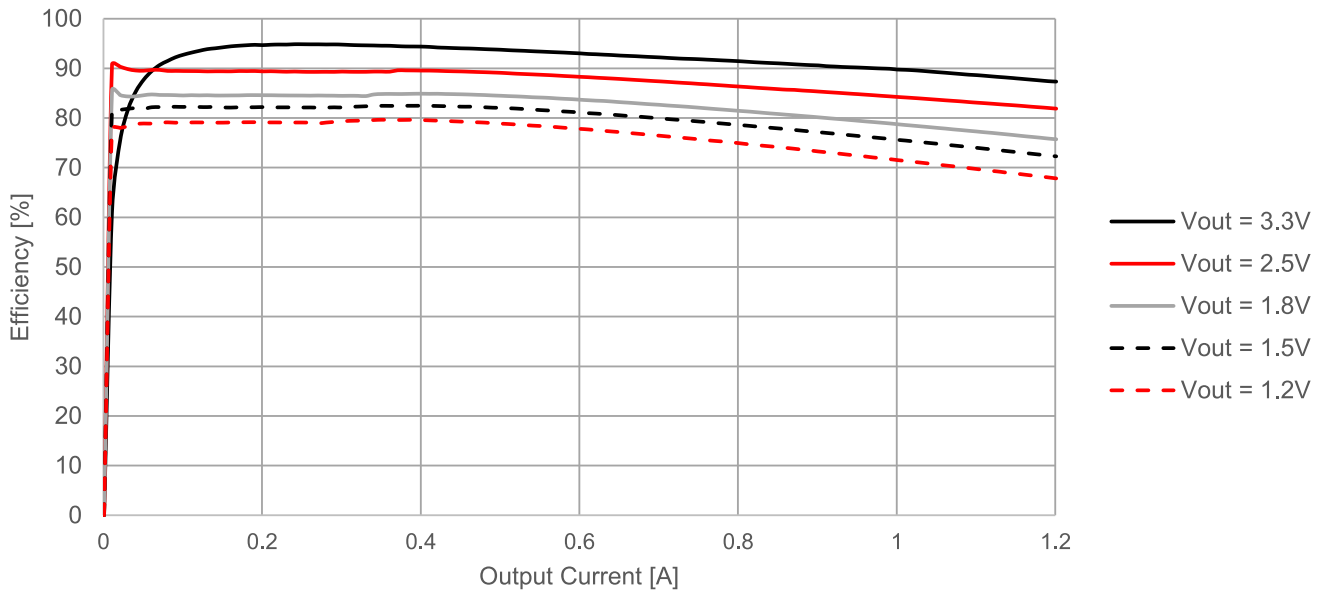

EFFICIENCY 3.3Vin POWER SAVE

171010550 $V_{IN} = 3.3V$, Power Save Mode, $T_A = 25^\circ C$

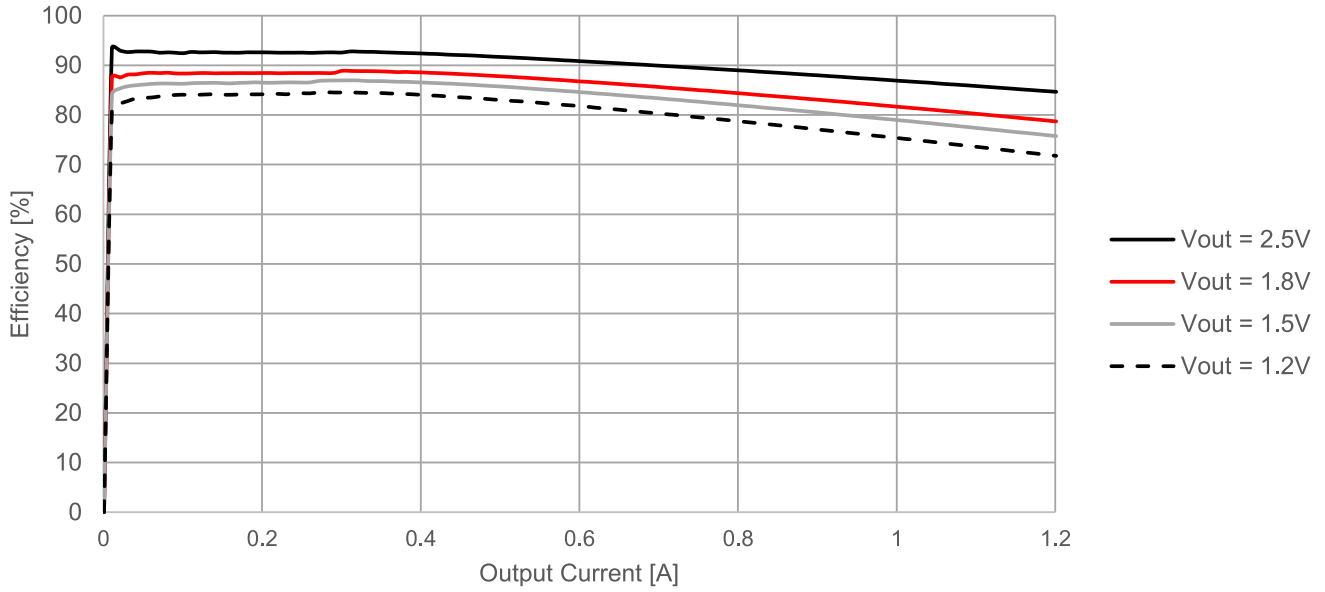

171010550 $V_{IN} = 3.3V$, Power Save Mode, $T_A = 85^\circ C$

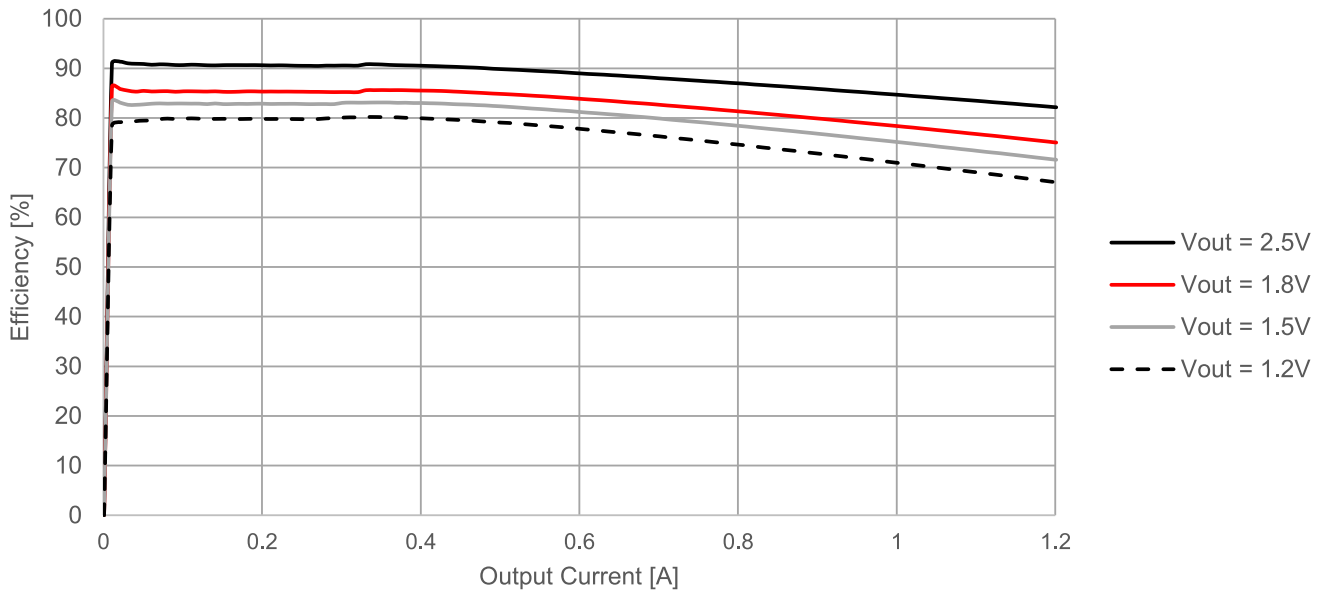

EFFICIENCY 5V_{in} FORCED COT

171010550 V_{IN} = 5V, Forced COT Mode, T_A = 25°C

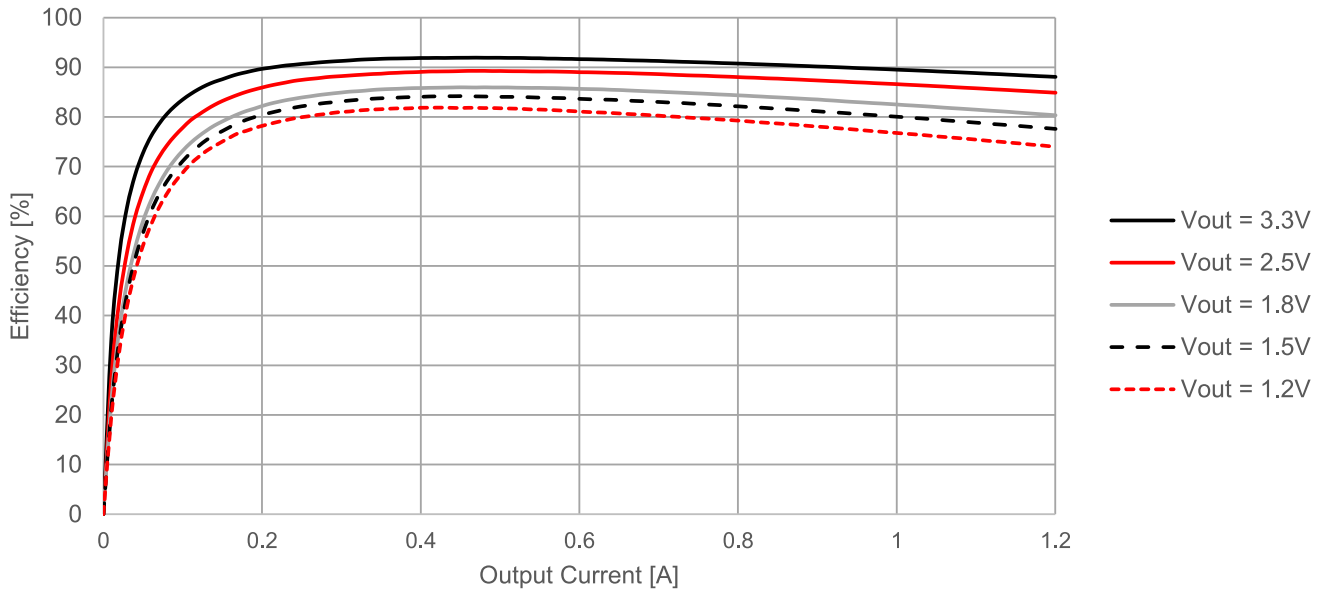

171010550 V_{IN} = 5V, Forced COT Mode, T_A = 85°C

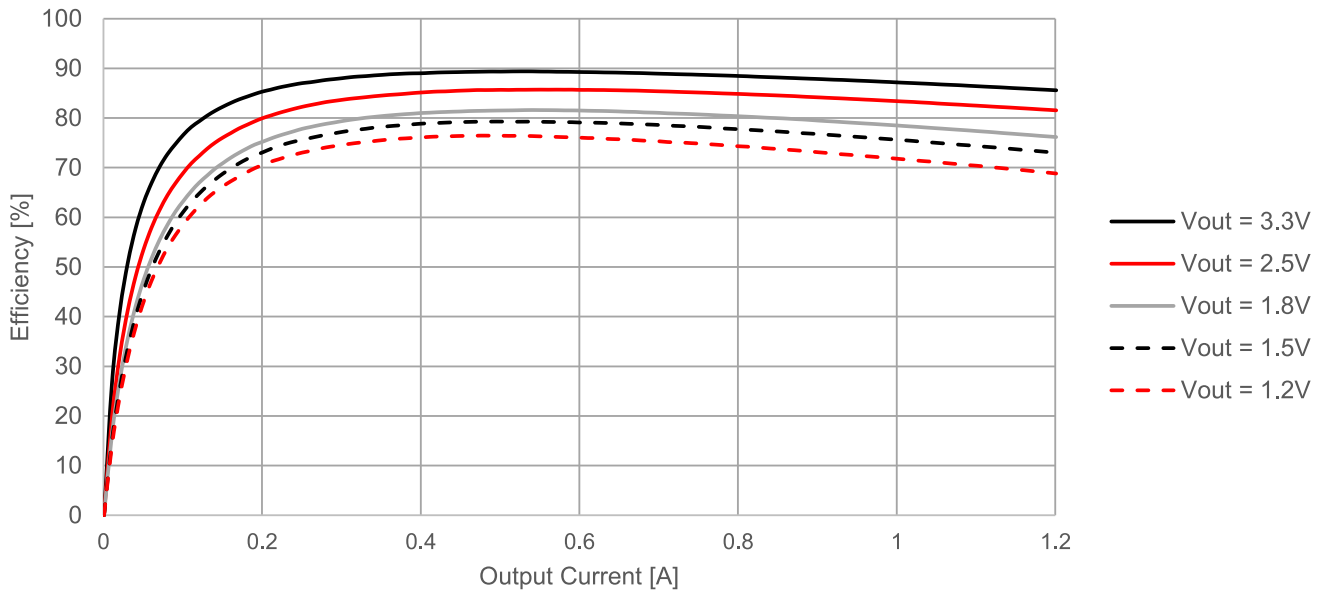

EFFICIENCY 3.6Vin FORCED COT

171010550 $V_{IN} = 3.6V$, Forced COT Mode, $T_A = 25^\circ C$

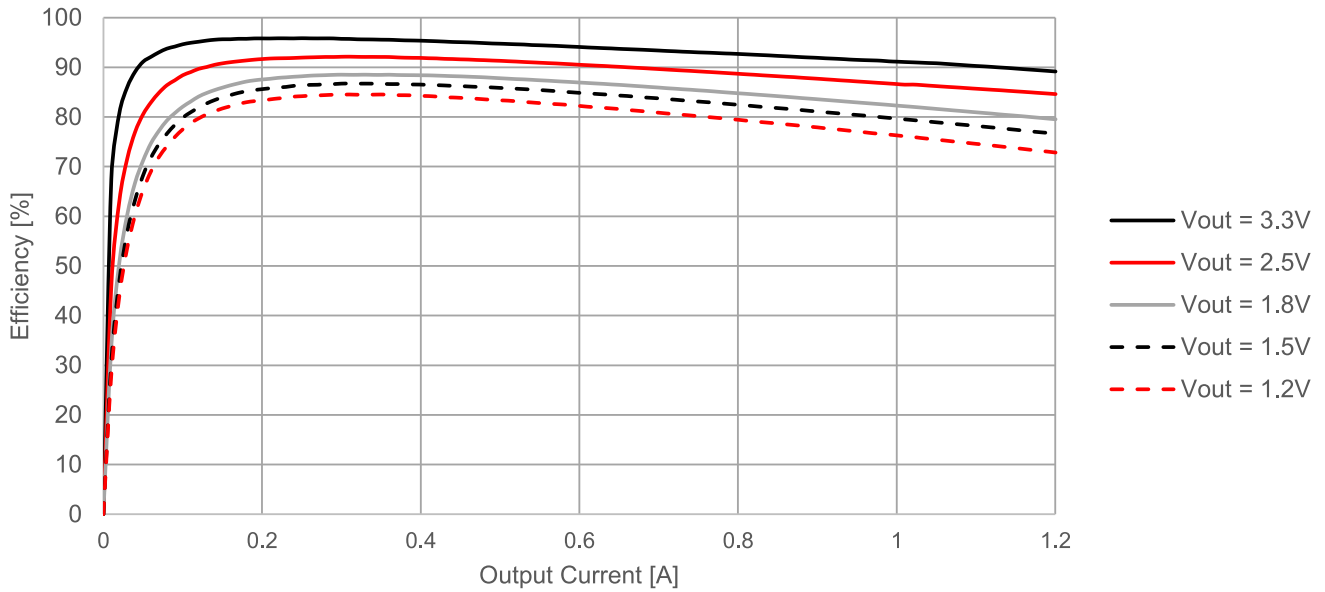

171010550 $V_{IN} = 3.6V$, Forced COT Mode, $T_A = 85^\circ C$

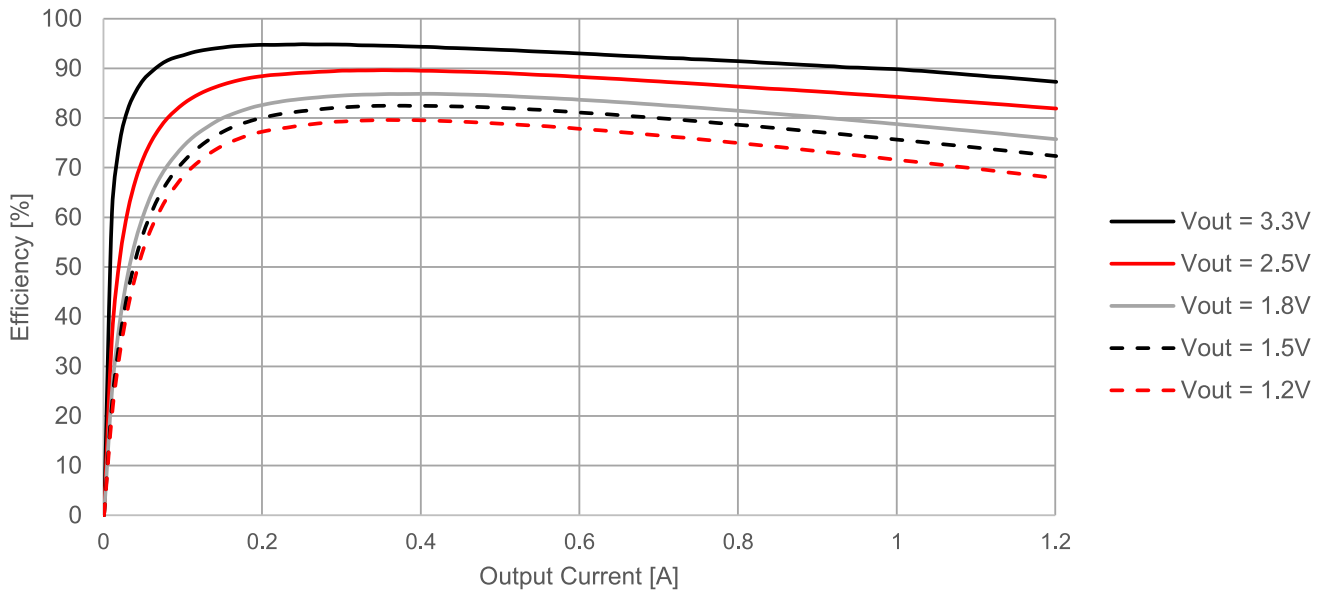

EFFICIENCY 3.3Vin FORCED COT

171010550 $V_{IN} = 3.3V$, Forced COT Mode, $T_A = 25^\circ C$

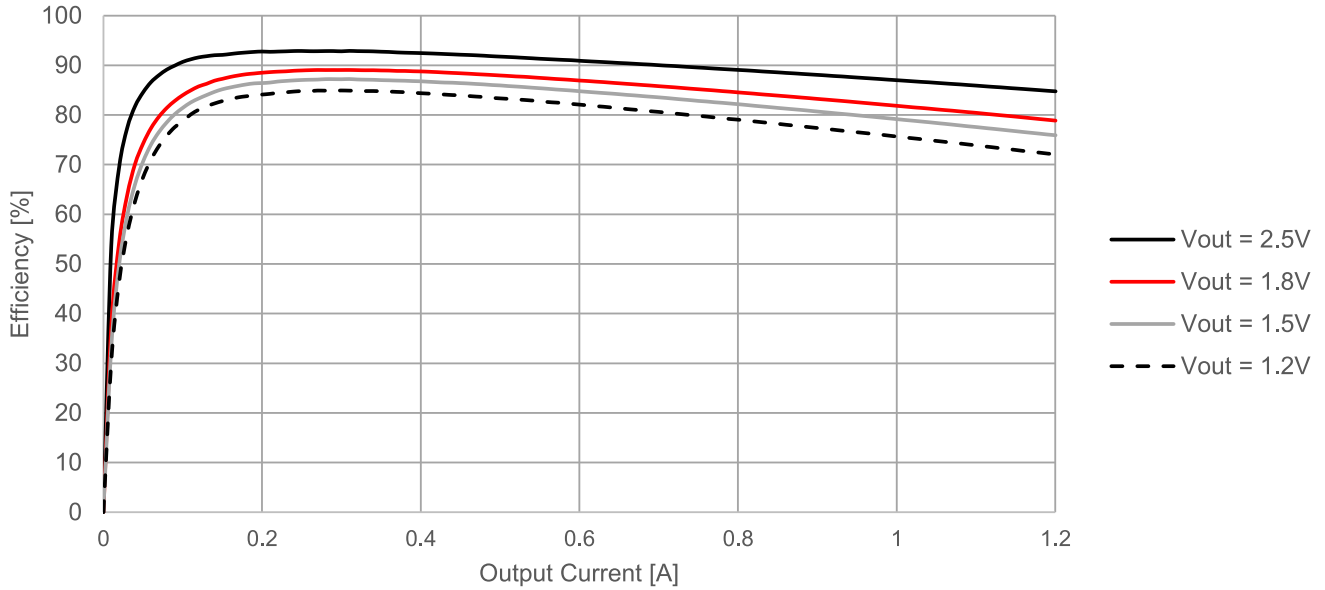

171010550 $V_{IN} = 3.3V$, Forced COT Mode, $T_A = 85^\circ C$

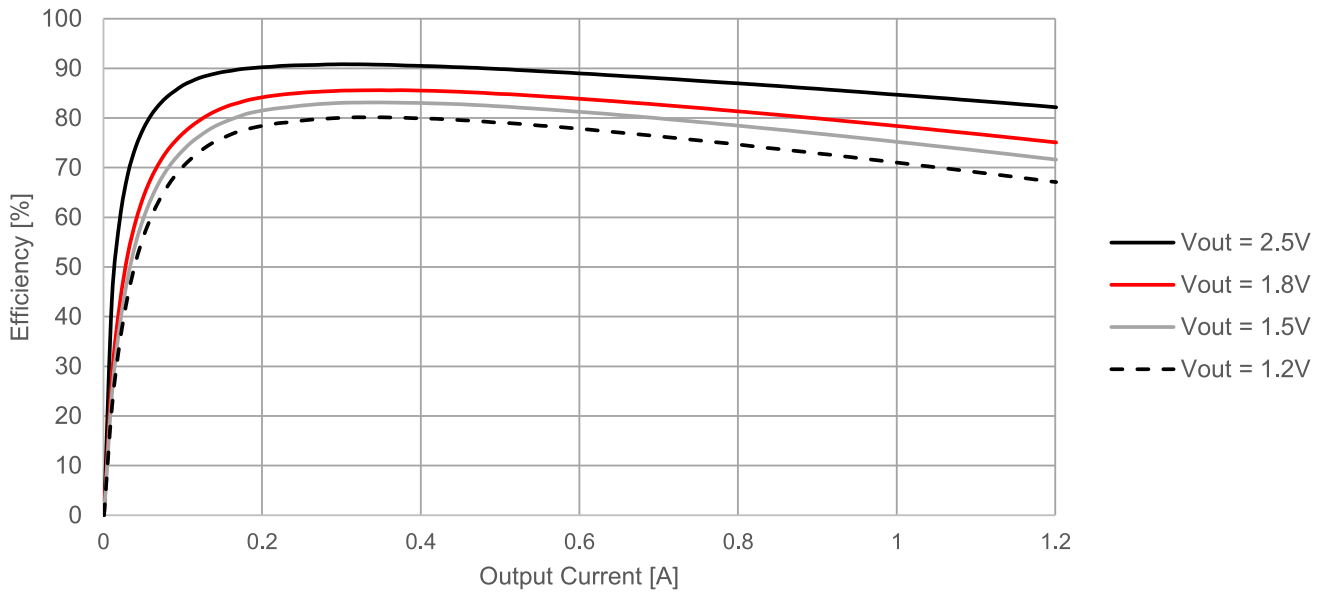

POWER DISSIPATION 5Vin POWER SAVE

171010550 $V_{IN} = 5V$, Power Save Mode, $T_A = 25^\circ C$

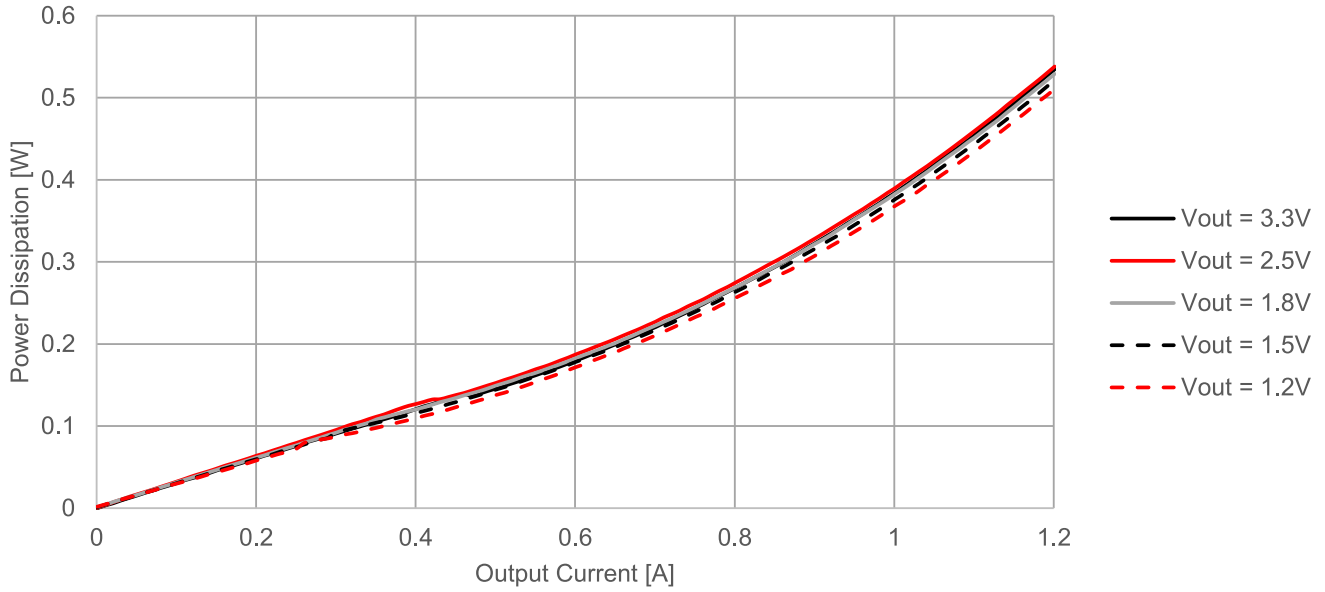

171010550 $V_{IN} = 5V$, Power Save Mode, $T_A = 85^\circ C$

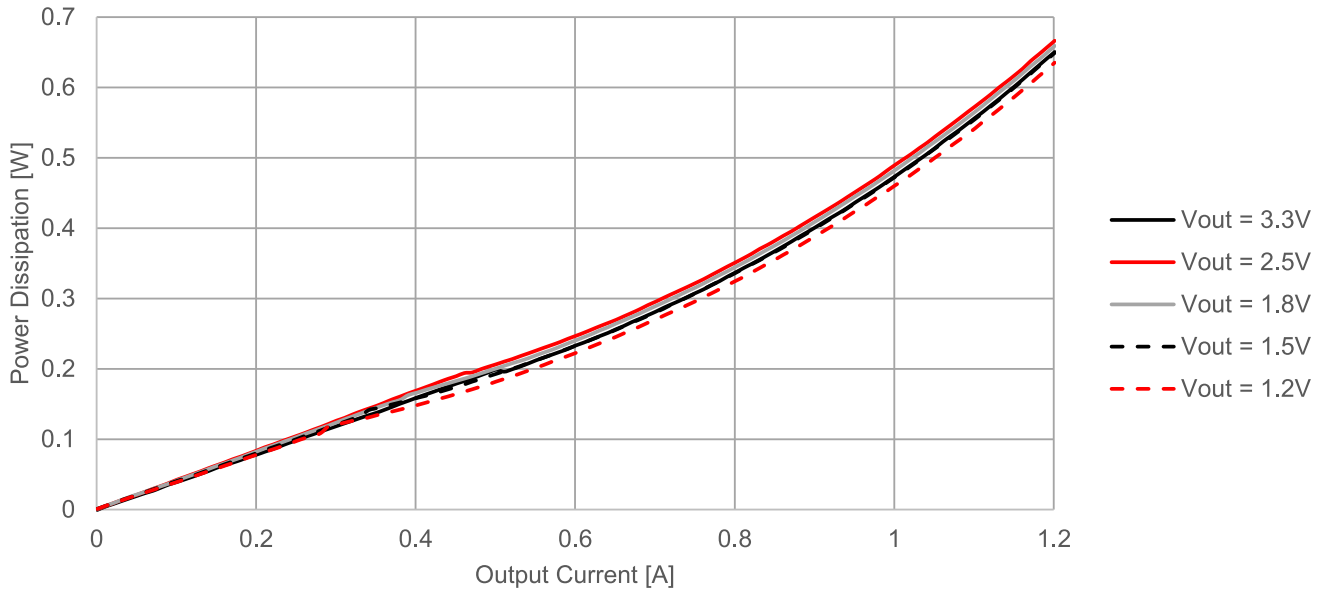

POWER DISSIPATION 3.6V_{in} POWER SAVE

171010550 V_{IN} = 3.6V, Power Save Mode, T_A = 25°C

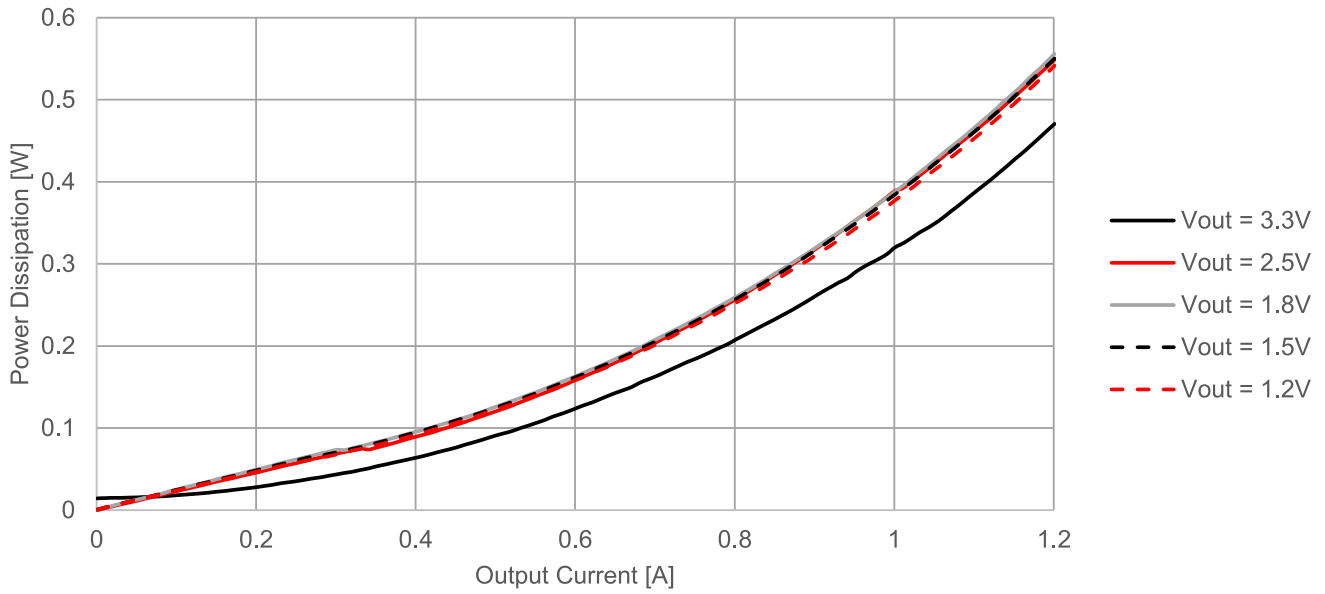

171010550 V_{IN} = 3.6V, Power Save Mode, T_A = 85°C

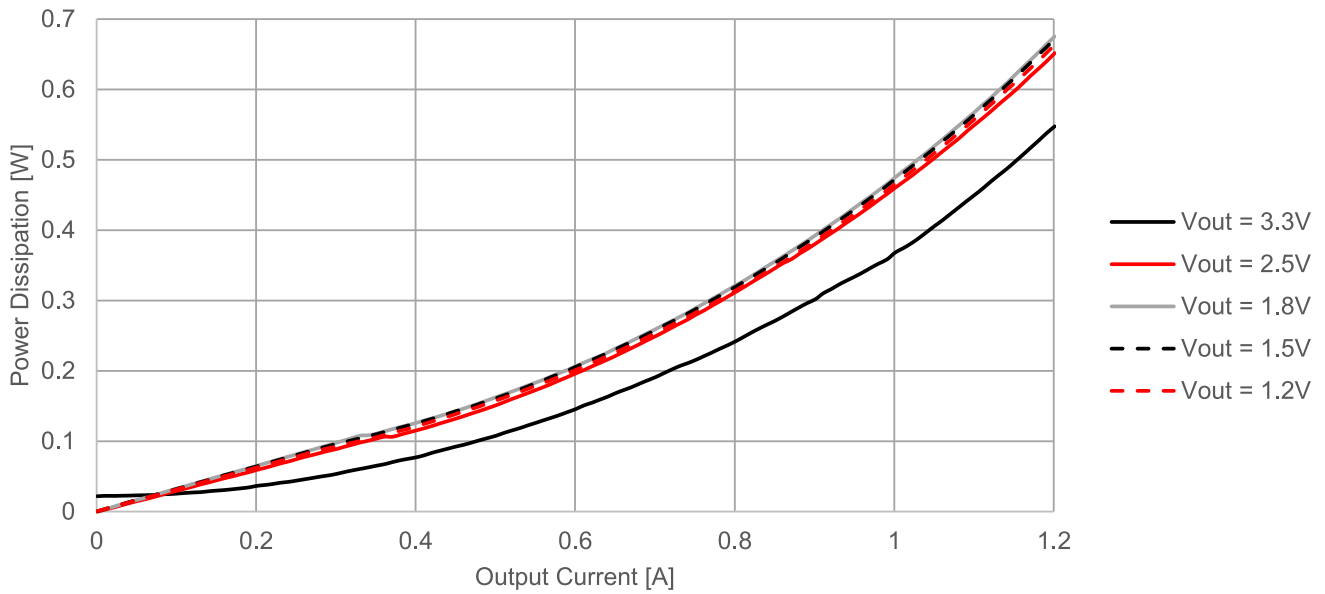

POWER DISSIPATION 3.3V_{in} POWER SAVE

171010550 V_{IN} = 3.3V, Power Save Mode, T_A = 25°C

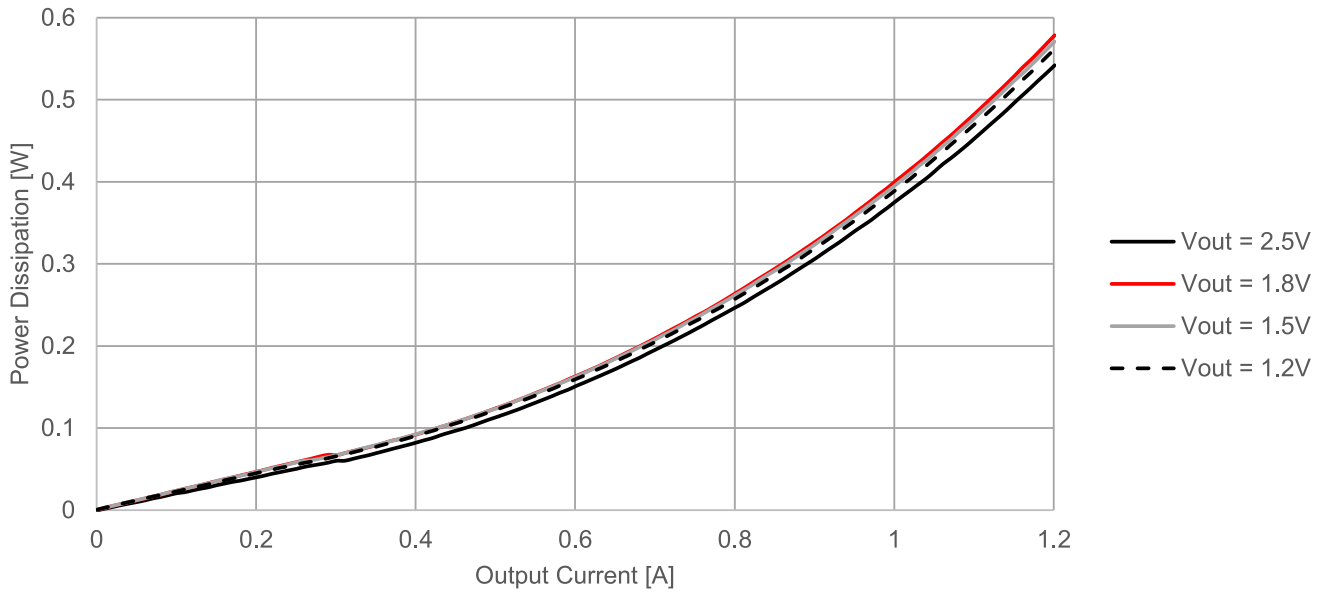

171010550 V_{IN} = 3.3V, Power Save Mode, T_A = 85°C

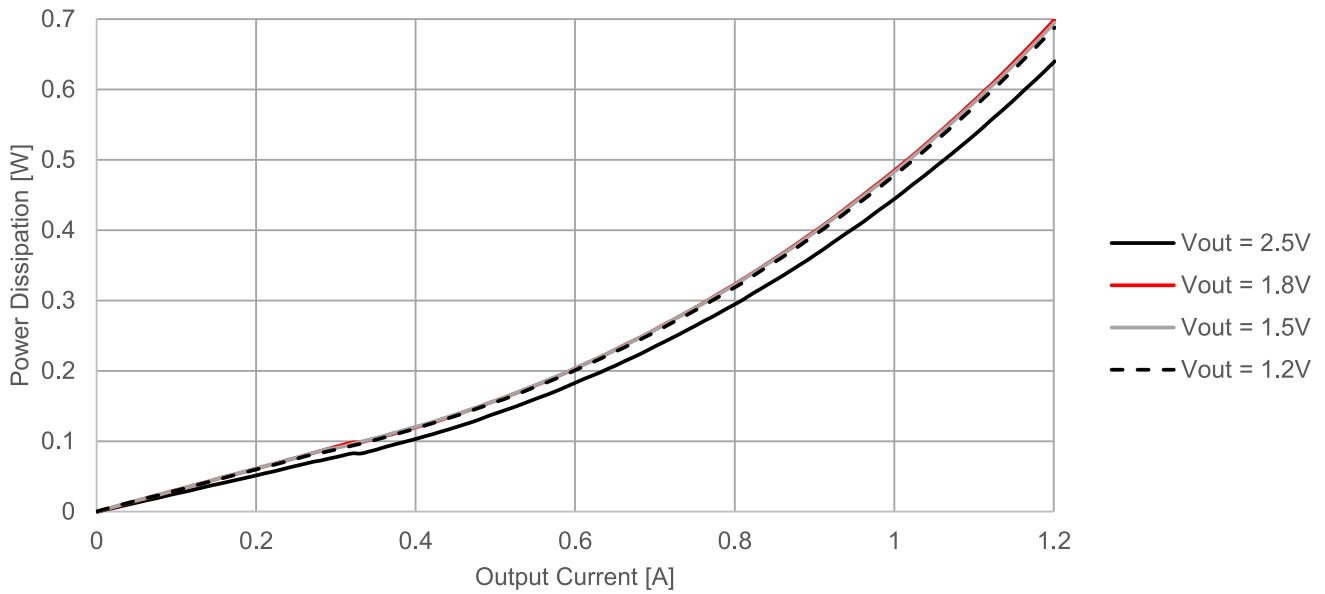

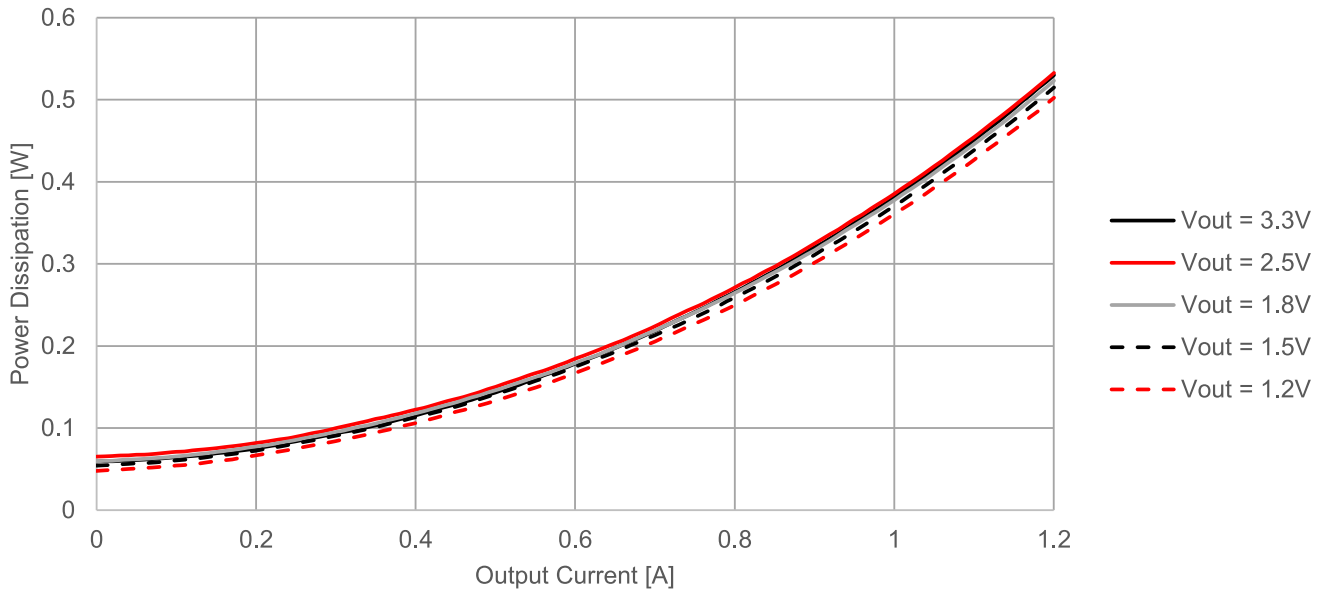
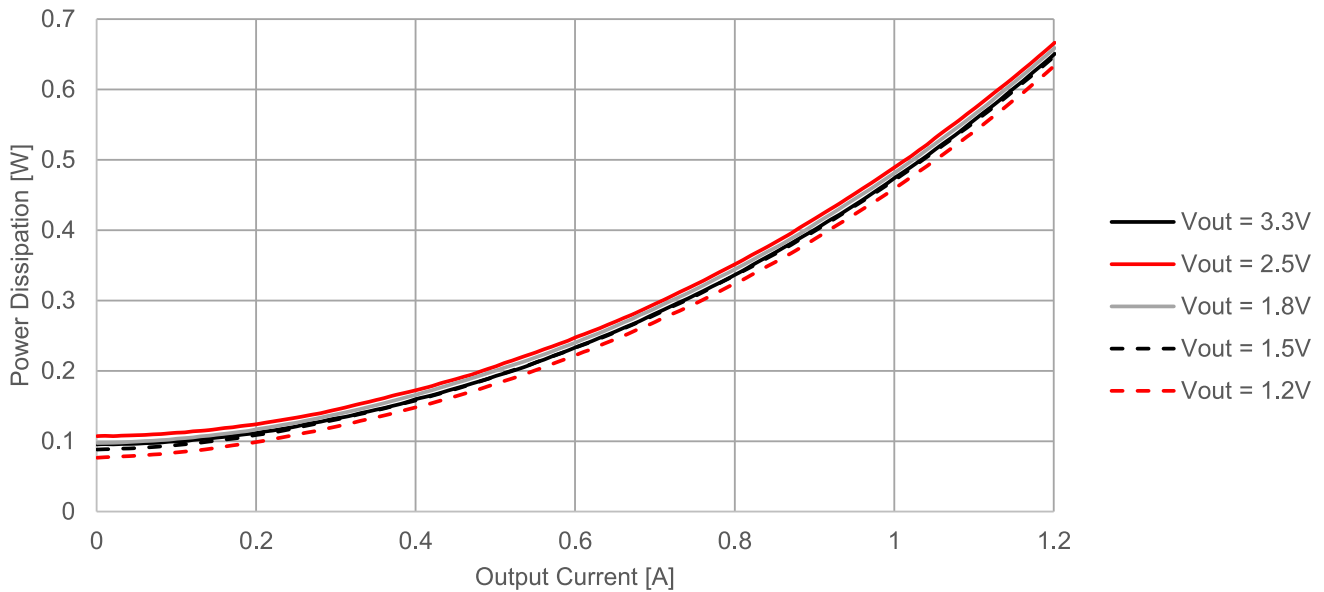
POWER DISSIPATION 5V_{in} FORCED COT171010550 V_{IN} = 5V, Forced COT Mode, T_A = 25°C171010550 V_{IN} = 5V, Forced COT Mode, T_A = 85°C

POWER DISSIPATION 3.6V_{in} FORCED COT

171010550 V_{IN} = 3.6V, Forced COT Mode, T_A = 25°C

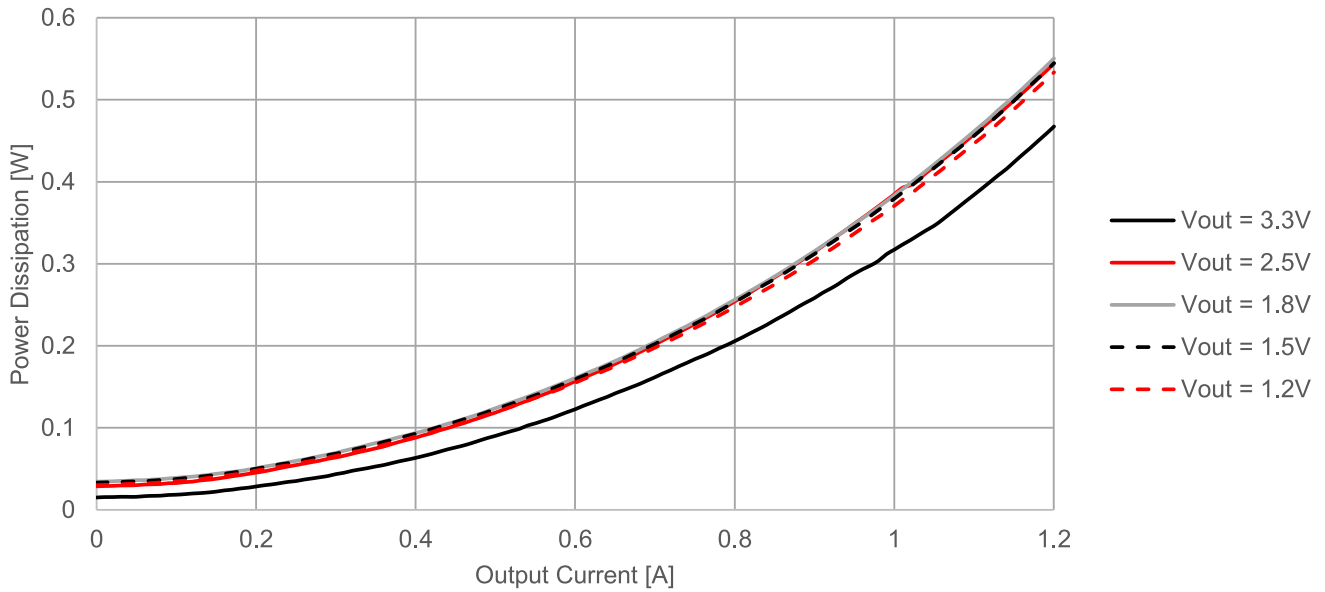

171010550 V_{IN} = 3.6V, Forced COT Mode, T_A = 85°C

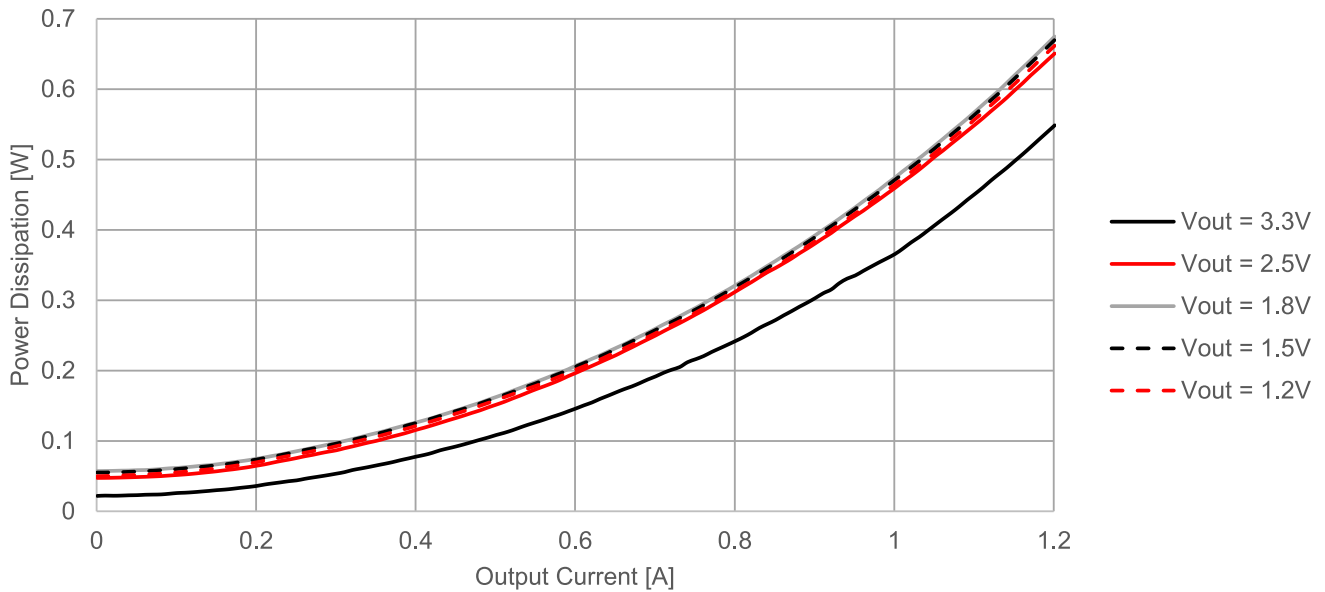

POWER DISSIPATION 3.3V_{in} FORCED COT

171010550 V_{IN} = 3.3V, Forced COT Mode, T_A = 25°C

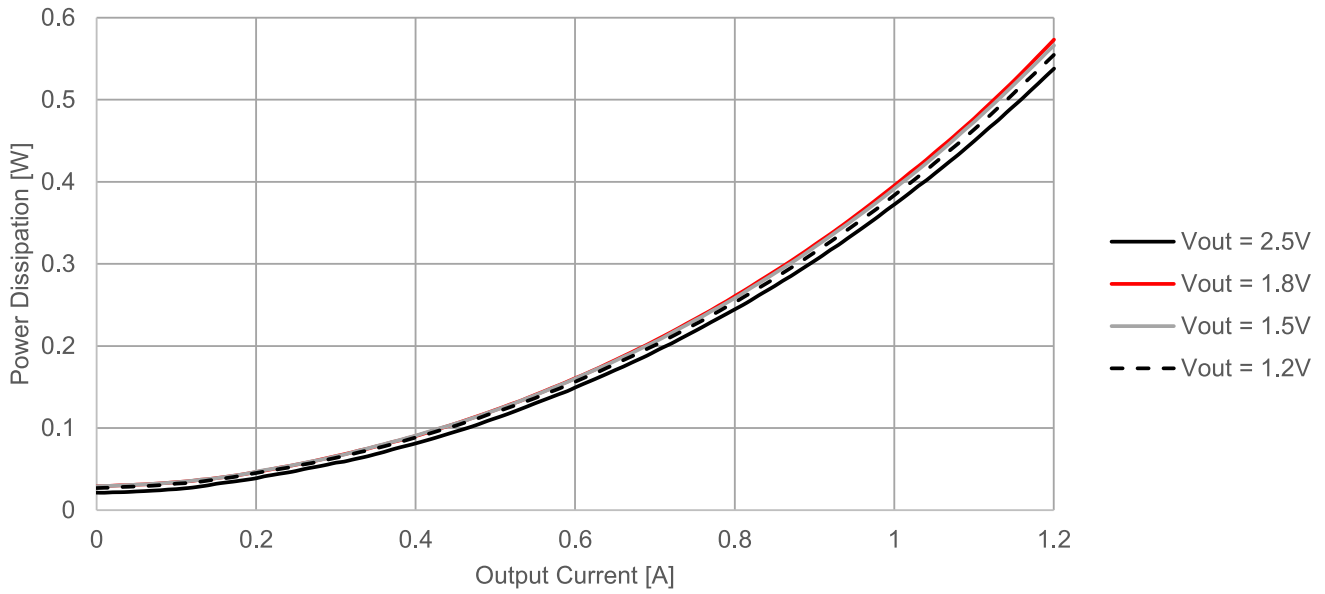

171010550 V_{IN} = 3.3V, Forced COT Mode, T_A = 85°C

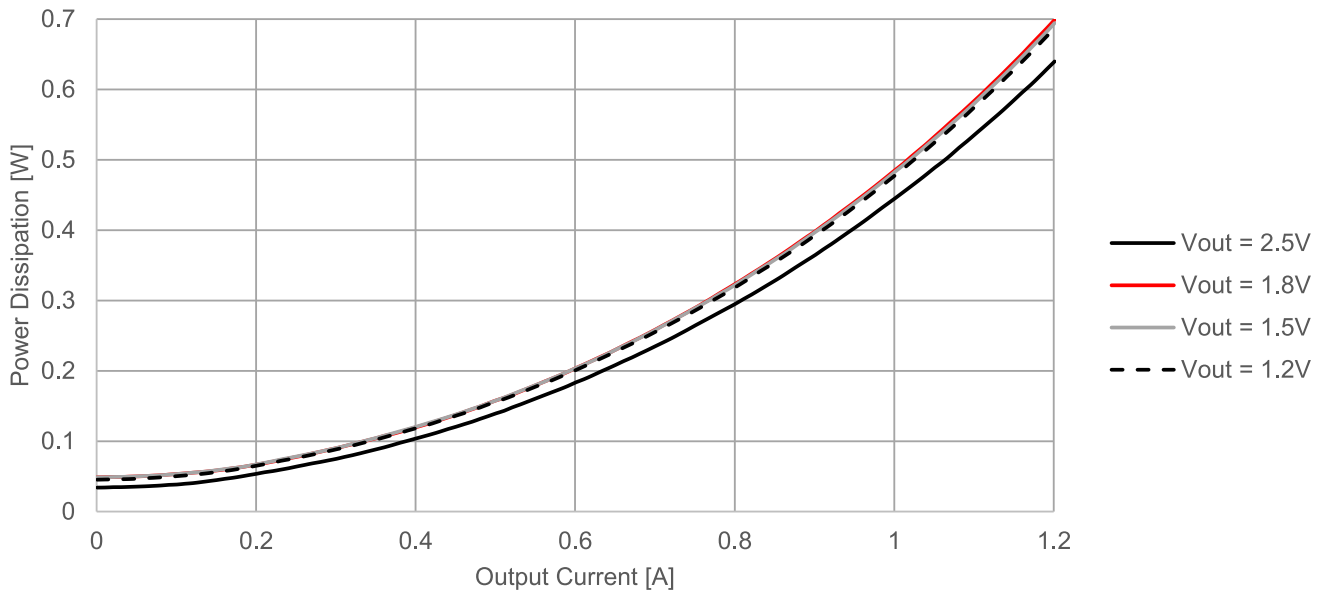

THERMAL DERATING

171010550 Current Thermal Derating $V_{IN} = 5V$, $V_{OUT} = 1.8V$, $\theta_{JA} = 110K/W$

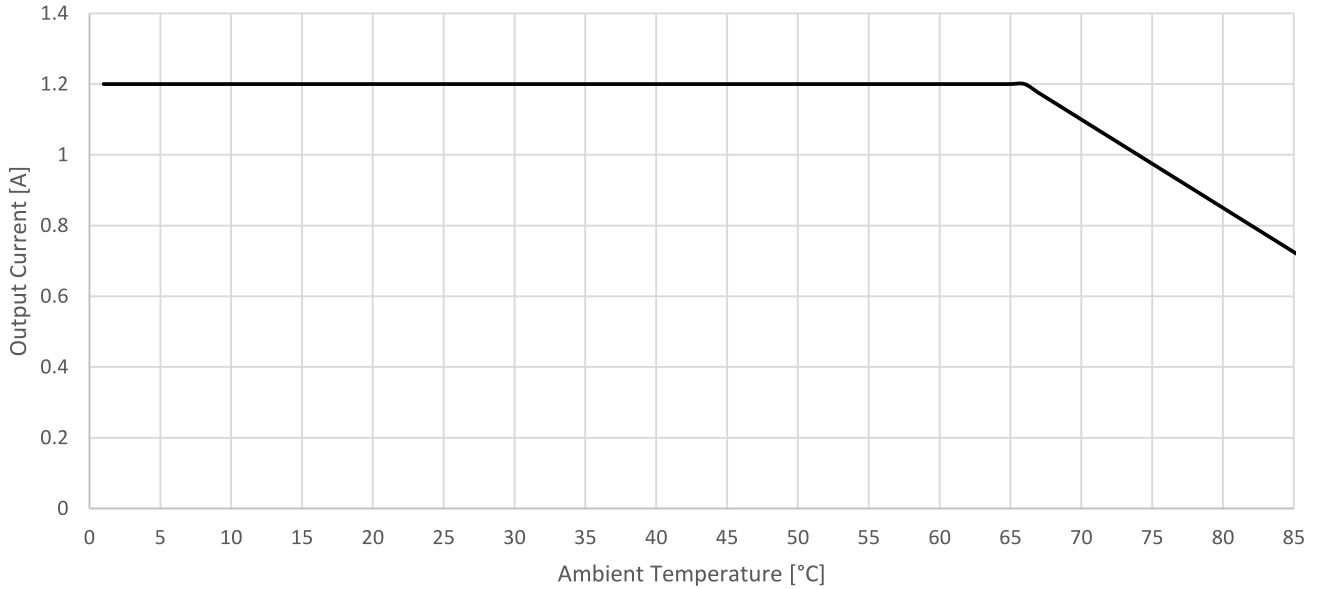

171010550 Current Thermal Derating $V_{IN} = 5V$, $V_{OUT} = 3.3V$, $\theta_{JA} = 110K/W$

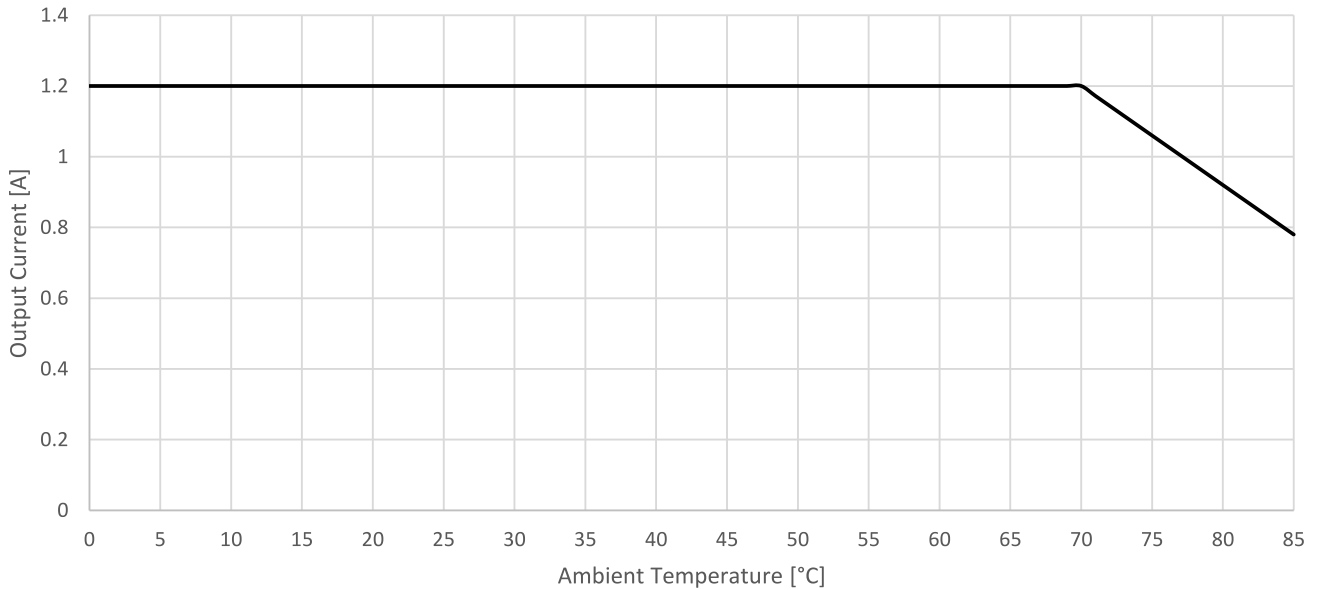

Note: Both thermal derating graphs were measured on the 178010550 Evaluation Board (40 x 40mm, two layers, 35µm copper thickness). Please see T_A limits in Operating Conditions on page 4.

LOAD REGULATION

171010550 Load Regulation $V_{IN} = 3.6V$, $V_{OUT} = 1.8V$, $T_A = 25^\circ C$

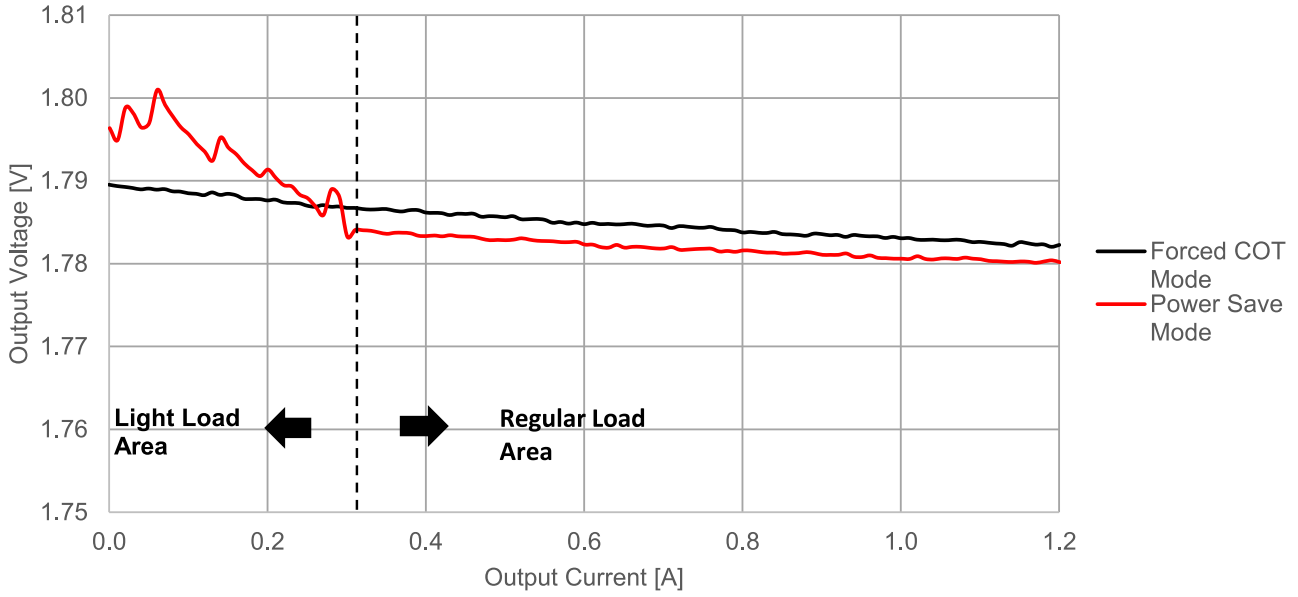

171010550 Load Regulation $V_{IN} = 3.6V$, $V_{OUT} = 1.8V$, $T_A = 85^\circ C$

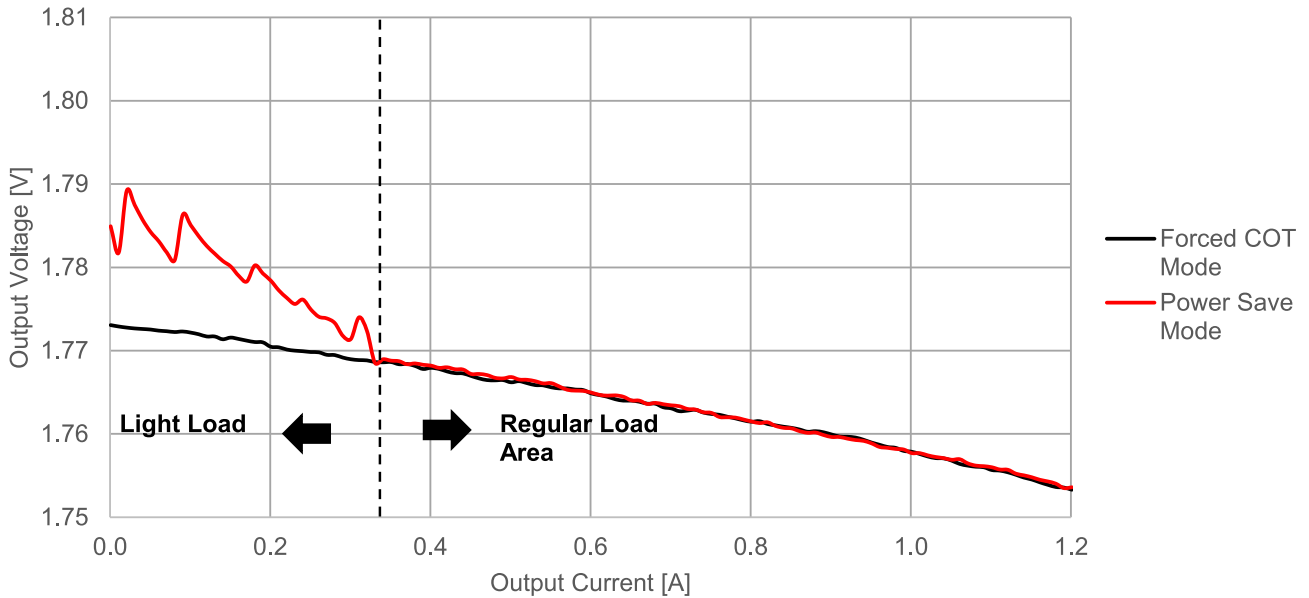

LINE REGULATION

171010550 Line Regulation $V_{OUT} = 1.8V$, $I_{OUT} = 1.2A$, $T_A = 25^\circ C$

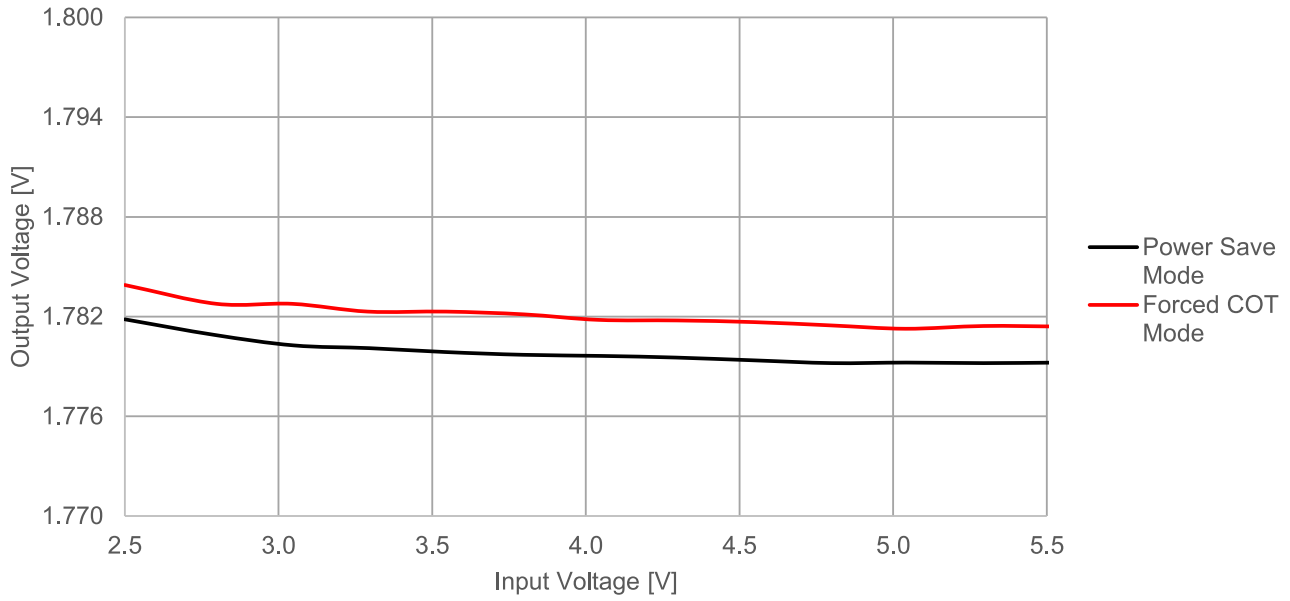

171010550 Line Regulation $V_{OUT} = 1.8V$, $I_{OUT} = 1.2A$, $T_A = 85^\circ C$

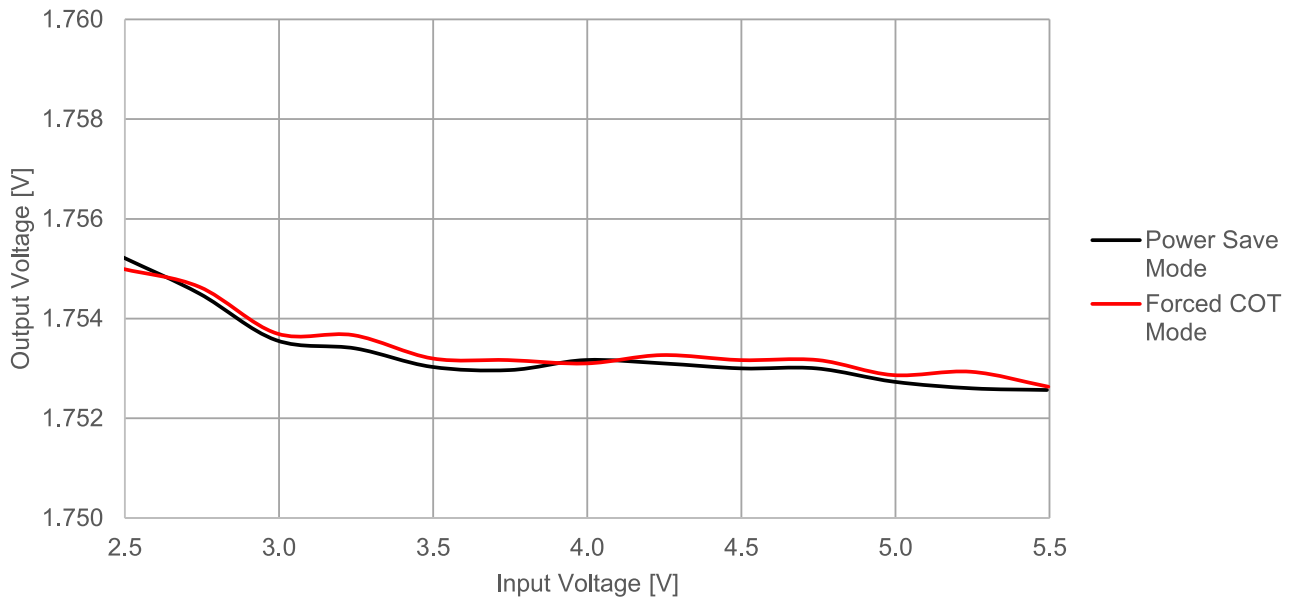

BLOCK DIAGRAM

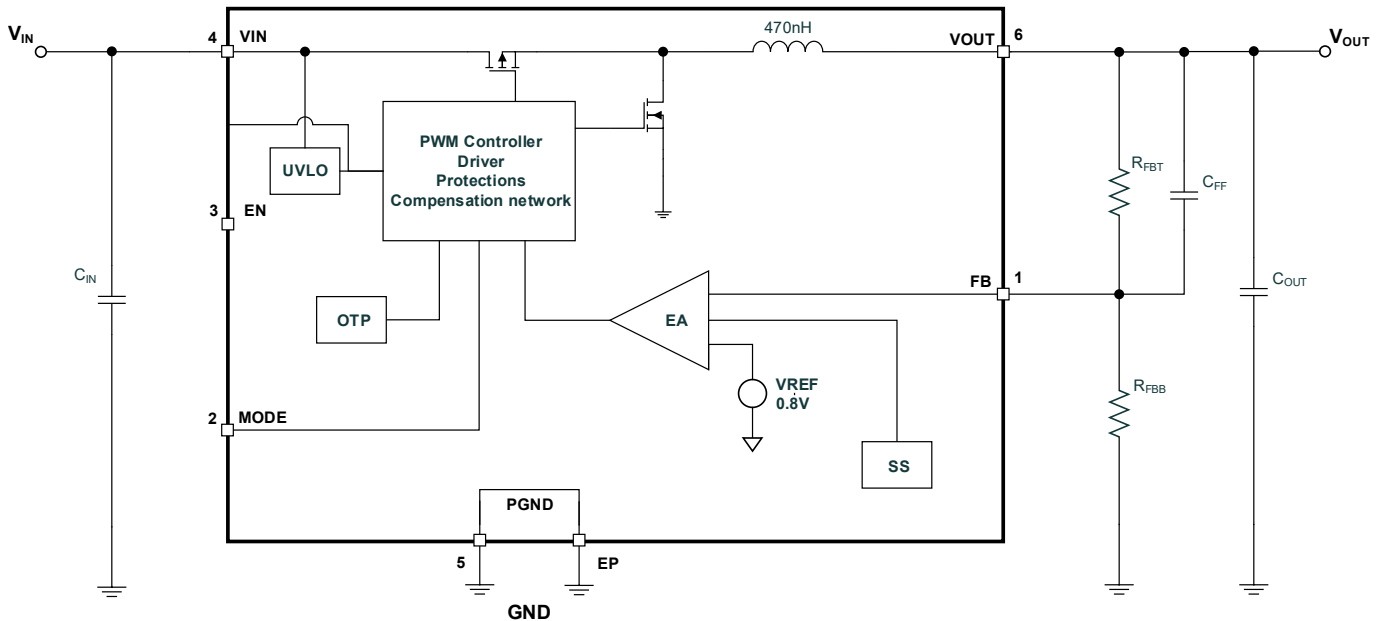

CIRCUIT DESCRIPTION

The MagI³C MicroModule 171010550 is a synchronous step down regulator with integrated MOSFETs, control circuitry and power inductor. The control scheme is based on a constant on-time (COT) regulation loop. An additional power saving mode for light load operation can be engaged based on the condition applied to the MODE pin.

The V_{OUT} of the regulator is divided by the feedback resistor network R_{FBT} and R_{FBB} and fed into the FB pin. The internal comparator compares this signal with the internal 0.8V reference. If the feedback voltage is below the reference, the high side MOSFET is turned on for a fixed on-time.

The constant on-time control scheme does not require compensation circuitry which makes the overall design very simple. Nevertheless, it requires a certain minimum ripple at the feedback pin. The MagI³C Power Module 171010550 generates this ripple internally and is supported by the C_{FF} capacitor which bypasses AC ripple directly to the feedback pin from the output. With this architecture very small output ripple values under $10mV_{PP}$ (similar to current or voltage mode devices) can be achieved.

DESIGN FLOW

The next four simple steps will show how to select the external components to design the 171010550 into an application.

Essential Steps

1. Set output voltage
2. Select input capacitor
3. Select output capacitor
4. Select feed-forward capacitor

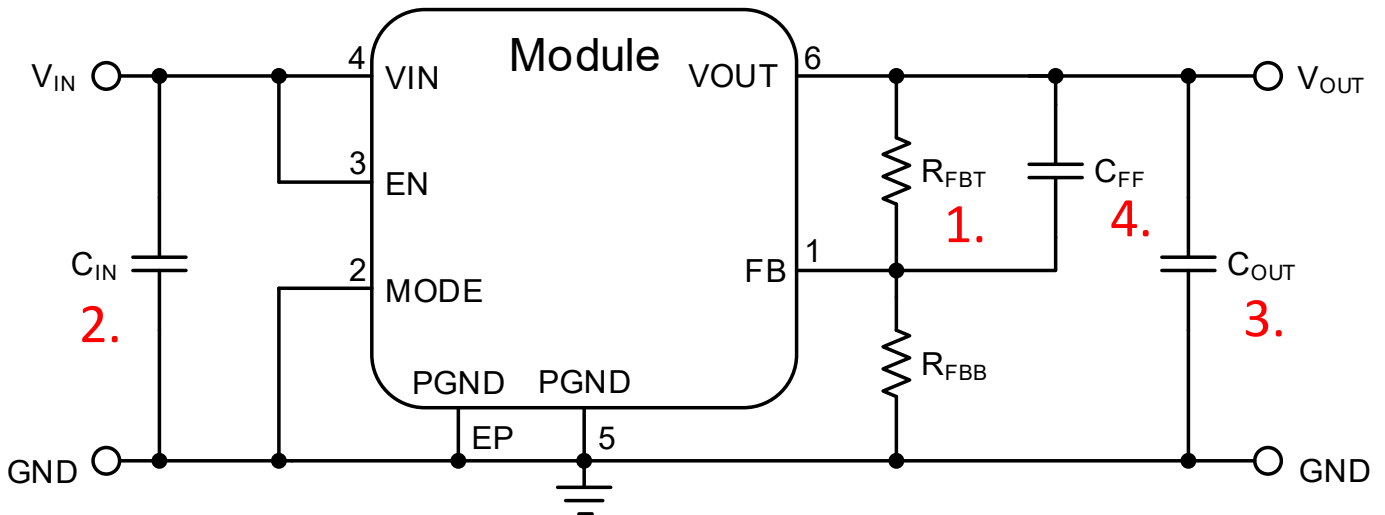

STEP 1 Setting The Output Voltage (V_{OUT})

The output voltage is selected with an external resistor divider between V_{OUT} and GND (see circuit below). The voltage across the lower resistor of the divider is provided to the FB pin and compared with an internal reference voltage of 0.8V (V_{REF}). The output voltage adjustment range is from 0.8V to 5.5V. The output voltage can be calculated according to the following formula:

$$V_{OUT} = V_{REF} \cdot \left(\frac{R_{FBT}}{R_{FBB}} + 1 \right) \quad (1)$$

One resistor must be chosen and then the other resistor can be calculated. For example, if $R_{FBT} = 100\text{k}\Omega$ then the resistance value of the lower resistor in the feedback network is indicated in the table below for common output voltages.

V_{OUT} (V)	1.2	1.5	1.8	2.5	3.3	3.6	5
R_{FBB} (E96) (k Ω)	200	115	80.6	47.5	32.4	28.7	13.8

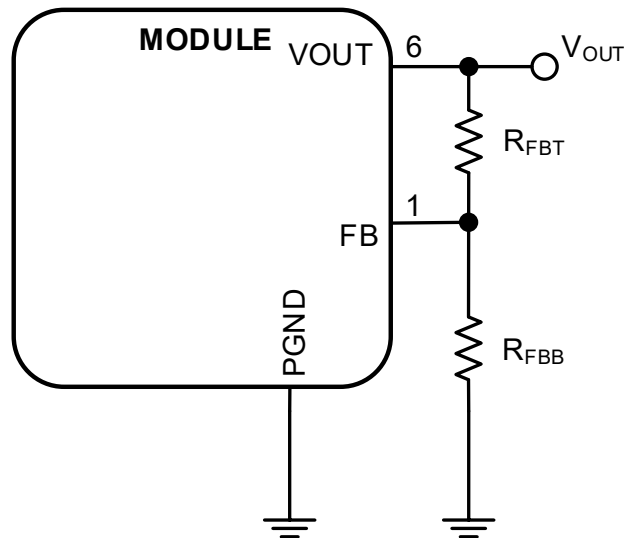

STEP 2 Select The Input Capacitor (C_{IN})

An external input capacitor is required to provide the high input pulse current. The external input capacitor must be placed as close as possible to the VIN and PGND pins. For this MagI³C MicroModule, it is recommended to use an MLCC (multi-layer ceramic capacitor) of 4.7µF. Attention must be paid to the voltage, frequency, temperature derating and thermal class of the selected capacitor. The Würth Elektronik part number 885012107018 has been experimentally verified to work with this MicroModule.

STEP 3 Select The Output Capacitor (C_{OUT})

The output capacitor should be selected in order to minimize the output voltage ripple and to provide a stable voltage at the output. It also affects the loop stability. An external MLCC of 10µF is recommended for all application conditions. Attention must be paid to the voltage, frequency, temperature derating and thermal class of the selected capacitor. The Würth Elektronik part numbers 885012107010 and 885012107014 have been experimentally verified to work with this MicroModule.

In general, the output voltage ripple can be calculated using the following equation:

$$V_{OUT\ ripple} = \Delta I_L \cdot ESR + \Delta I_L \cdot \left(\frac{1}{8 \cdot f_{SW} \cdot C_{OUT}} \right) \quad (2)$$

where ΔI_L is the inductor current ripple and can be calculated with the following equation:

$$\Delta I_L = \frac{V_{OUT} \cdot (V_{IN} - V_{OUT})}{f_{SW} \cdot L \cdot V_{IN}} \quad (3)$$

Example

In the section OUTPUT VOLTAGE RIPPLE on page 35, a ripple measurement is shown under the following conditions:

$$V_{IN} = 3.6V$$

$$V_{OUT} = 1.8V$$

$$L = 470nH \text{ (internally fixed)}$$

$$f_{SW} = 4MHz \text{ (internally fixed)}$$

$$C_{OUT} = 10\mu F \text{ X5R 0805 10V (Würth Elektronik part number 885012107010)}$$

Assuming a reduction of the capacitance of about 10% due to the bias voltage, a remaining capacitance of around 9µF can be considered. Another assumption can be used for the ESR, which can be considered lower than 10mΩ. Using Equations (2) and (3), the expected ripple is $V_{OUT_Ripple} \leq 6mV$, which matches the results obtained in the measurement.

STEP 4 Select The Feed-Forward Capacitor (C_{FF})

The 171010550 MagI³C MicroModule allows for the selection of a feed forward capacitor, C_{FF} , providing a trade-off between response time and efficiency while also affecting the transition current threshold between the COT and power save modes. A lower value of C_{FF} will increase the light load conversion efficiency while slowing down the response time and increasing the overshoot and undershoot. Increasing the C_{FF} value will decrease the response time and the overshoot and undershoot while decreasing light load conversion efficiency. Increasing the value of C_{FF} results in higher value of current needed to leave power save mode.

A C_{FF} of 22pF has been evaluated experimentally as a value with suitable efficiency and transient characteristics for most applications.

The pictures below show the transient behavior of the 171010550 in response to a load transition from 0A to 1.2A using the recommended $C_{FF} = 22\text{pF}$, as well as other values of C_{FF} .

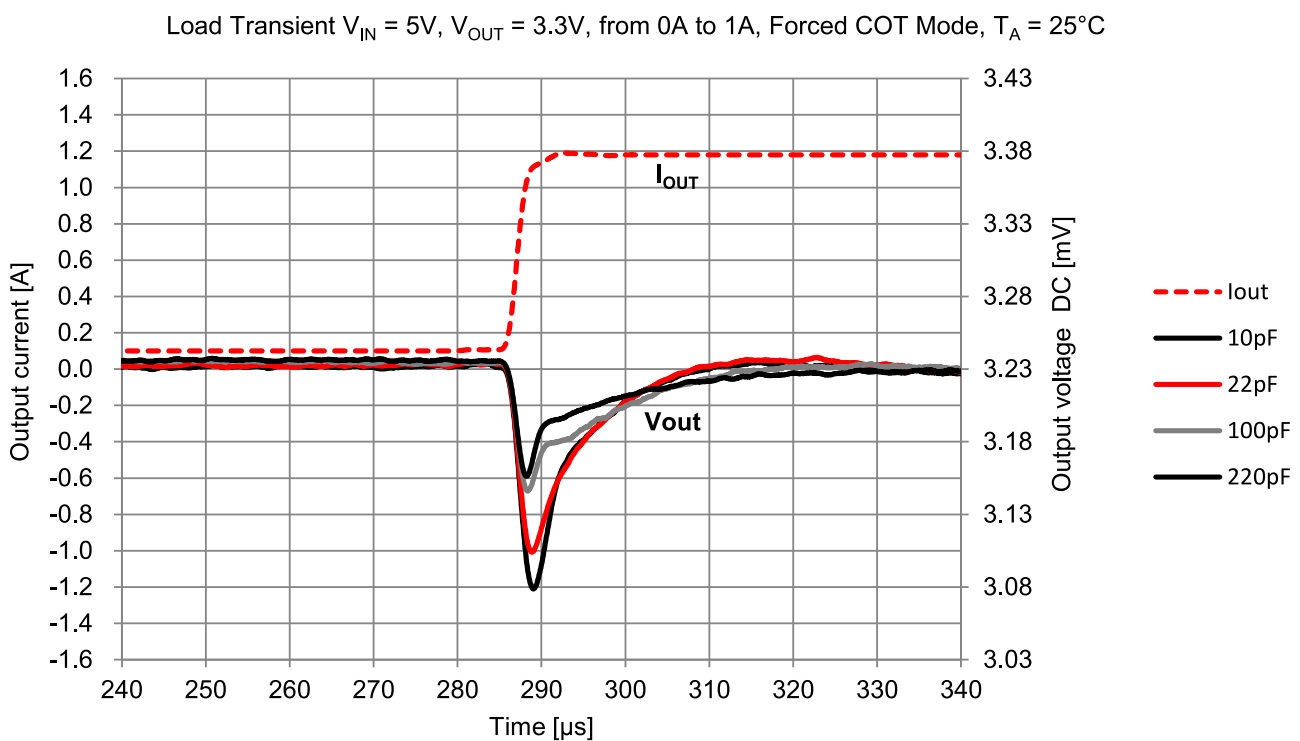

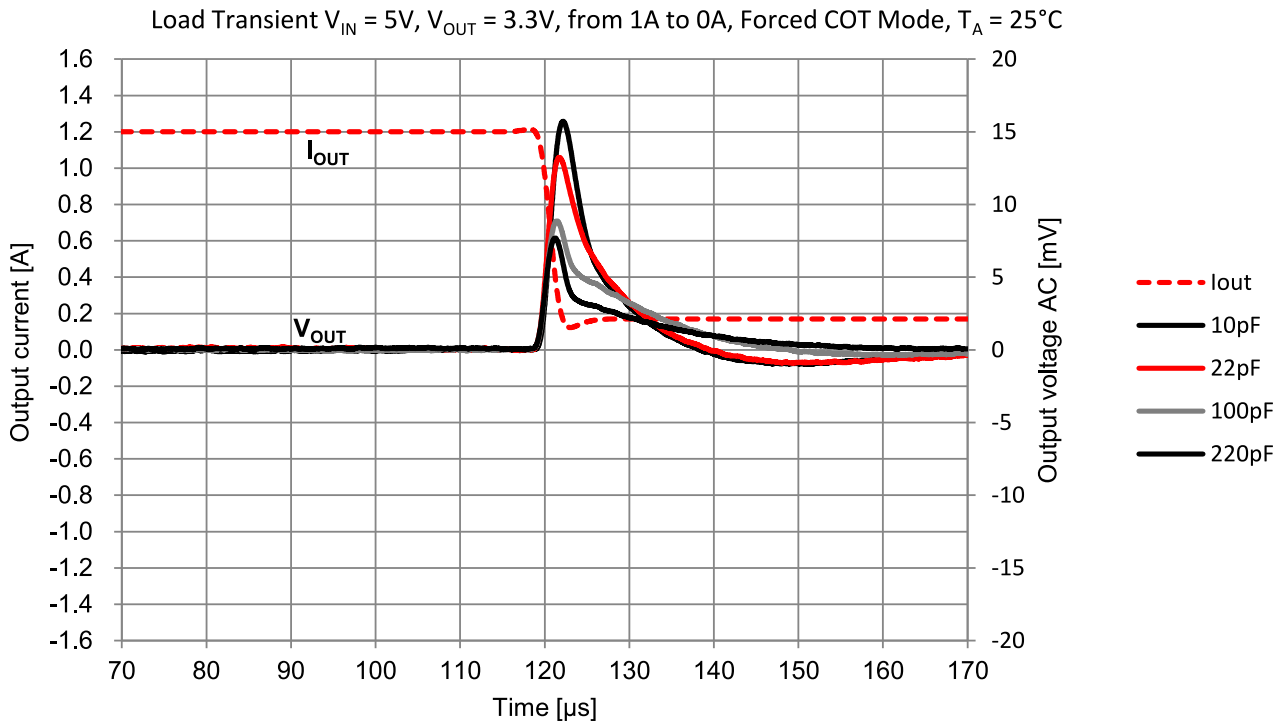

This behavior is valid only for this test under the specified conditions and must be verified in the real application.

The C_{FF} value only affects the efficiency during light load conditions when the power save mode is chosen.

As explained in the section MODES OF OPERATION on page 32, during light load conditions while the module is operating in power save mode (i.e. when the MODE pin is pulled to GND), the device does not continuously switch, instead delivering energy to the load in bursts. The frequency between bursts is influenced by various parameters, including the C_{FF} value. The LIGHT LOAD OPERATION section provides a more in-depth explanation of the additional parameters which affect behavior in this region.

Increasing C_{FF} will cause the MicroModule to burst more often, resulting in a decrease in light load efficiency as depicted in the diagram below. In addition, increasing the C_{FF} value will result in an increase in the current threshold required to exit power save mode, also shown below as a difference of almost 100mA.

Increasing C_{FF} will cause the MicroModule to burst more often (shown in the two images above) resulting in a decrease in light load efficiency as depicted in the diagram below. In addition, increasing the C_{FF} value will result in an increase in the current threshold required to exit PFM mode, also shown below as a difference of almost 100mA.

VIN = 5.5V , VOUT = 3.3V Graph, TA = 25°C

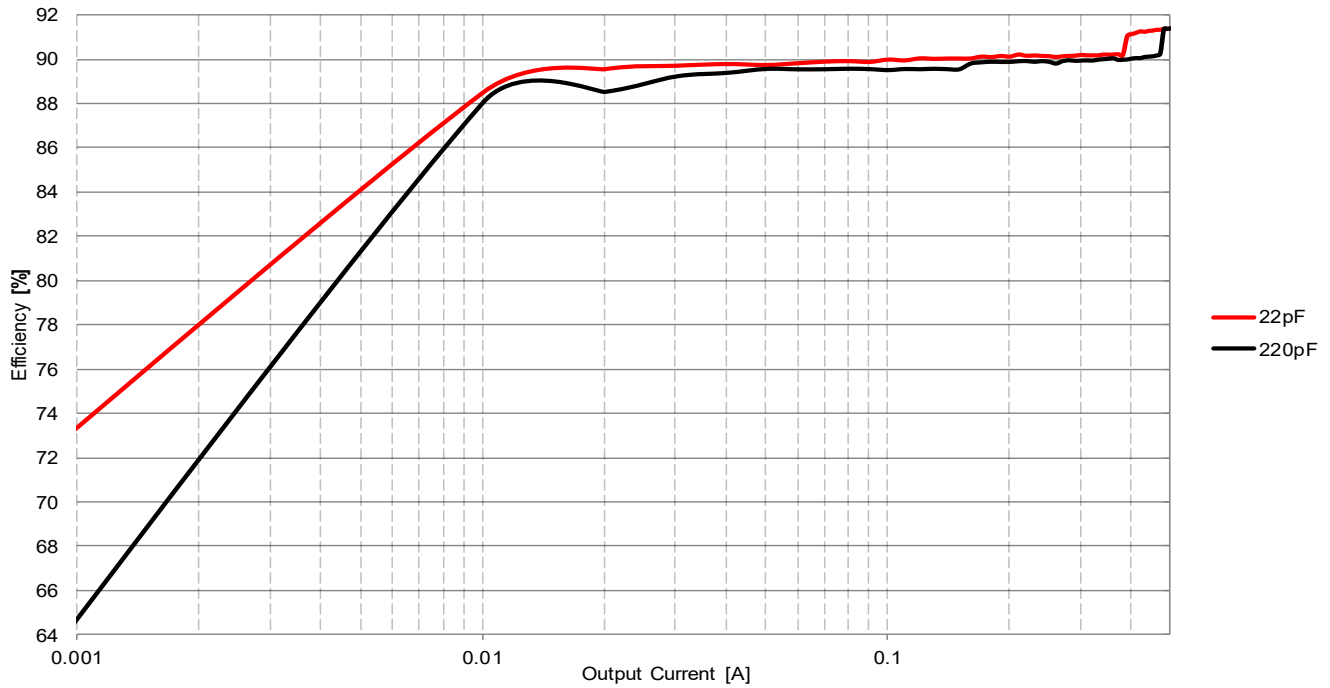

While the recommended C_{FF} value of 22pF will work for most applications, the user can adjust the performance of the MicroModule based on their application by trading between light load efficiency and transient response. This customization tailors the behavior of the MicroModule to the application's needs.

MODES OF OPERATION

The MODE pin of the 171010550 can be pulled either high or low to alter the light load performance of the module based on the application requirements.

When pulled high, COT operation will be forced throughout the entire load current range. When pulled low, power save operation will occur during light load conditions.

The MicroModule will operate in one of four modes, depending on the operating conditions.

Constant on-time (COT) operation

The MicroModule operates at a fixed switching frequency of 4MHz where the duty cycle (DC) is determined by the following equation:

$$DC = \frac{V_{OUT}}{V_{IN}} \quad (4)$$

The on-time is determined by the duty cycle and the switching frequency as follows:

$$t_{ON} = \frac{DC}{f_{SW}} \quad (5)$$

The on and off-times can be related to the switching frequency as follows:

$$\frac{1}{f_{SW}} = t_{ON} + t_{OFF} \quad (6)$$

This mode of operation has a minimum off-time value of 60ns.

Fixed off-time operation

When the minimum off-time of 60ns is reached and the duty cycle must increase further, the MicroModule fixes the off-time to 60ns and begins increasing the on-time. This results in a decrease in switching frequency proportional to the increase in duty cycle.

100% duty cycle operation

When the input voltage approaches the output voltage and the duty cycle approaches 100%, the MicroModule will leave the high side MOSFET on continuously and the output voltage will be limited by the input voltage. Further decreases of input voltage will result in a corresponding decrease in output voltage.

Power save operation

Power save operation is initiated when the MicroModule enters discontinuous mode, typically occurring between 0mA and 300mA. A burst of switching cycles increases the output voltage above the set value followed by a period of dead time where the output current is only delivered by the output capacitor. This results in slightly increased output voltage ripple in exchange for significantly increased conversion efficiency.

OUTPUT VOLTAGE RIPPLE

The output voltage ripple is also influenced by the selection of the MODE pin. If the forced COT mode is selected and the duty cycle is below 76%, the ripple is very low and it always has the same frequency as the internal oscillator (4MHz typ.). If the power save mode is selected and the load current is low enough to be in power save operation or if the duty cycle is high enough to enter the constant off-time mode of operation then the output voltage ripple will be higher and the frequency lower than the nominal switching frequency (see pictures below).

Low Load Current

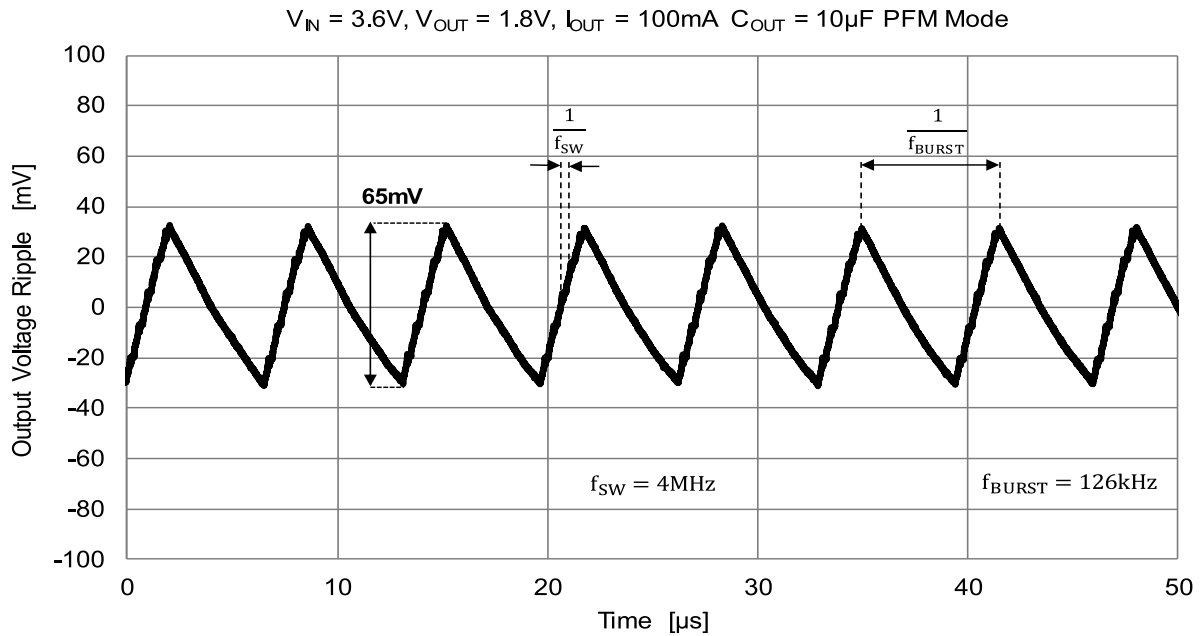

Full Load Current

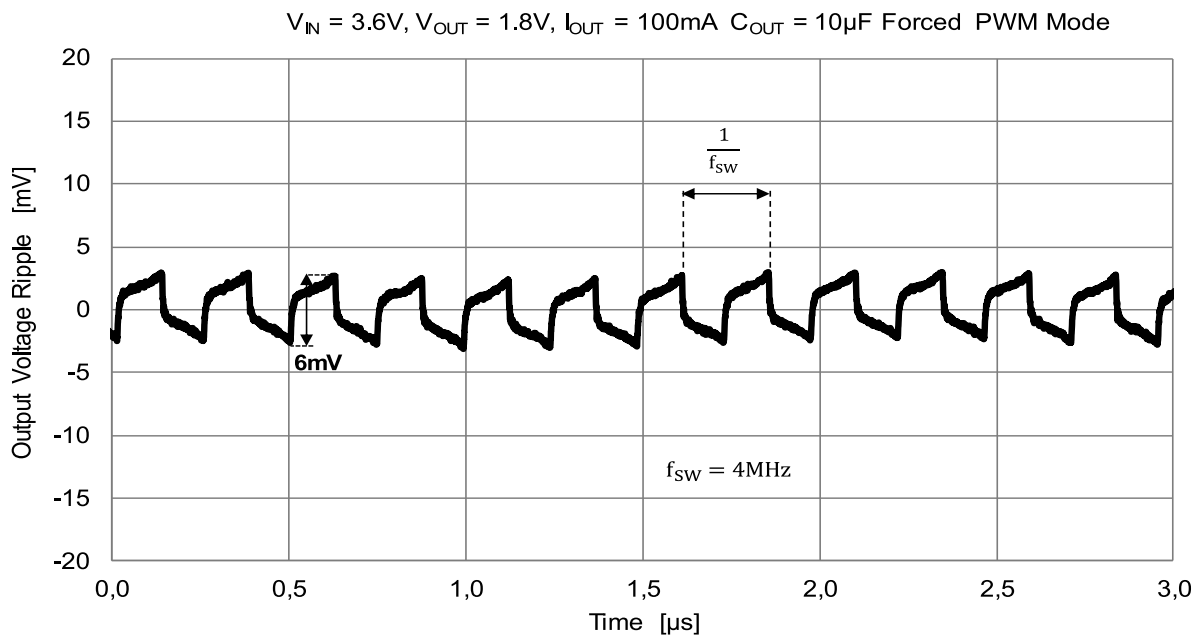

PROTECTION FEATURES

Overcurrent Protection (OCP)

For protection against load faults, the 171010550 MagI³C MicroModule incorporates a cycle-by-cycle current limiting (see I_{OCP} in ELECTRICAL SPECIFICATION on page 5). During switching, the output current is limited by turning off the high-side switch when the current limit value is detected. This switching behavior continues, limiting the on-time of the device until the overcurrent condition is removed. When the overcurrent condition is removed, normal switching times resume. The output voltage is reduced to zero until the current no longer exceeds the limit.

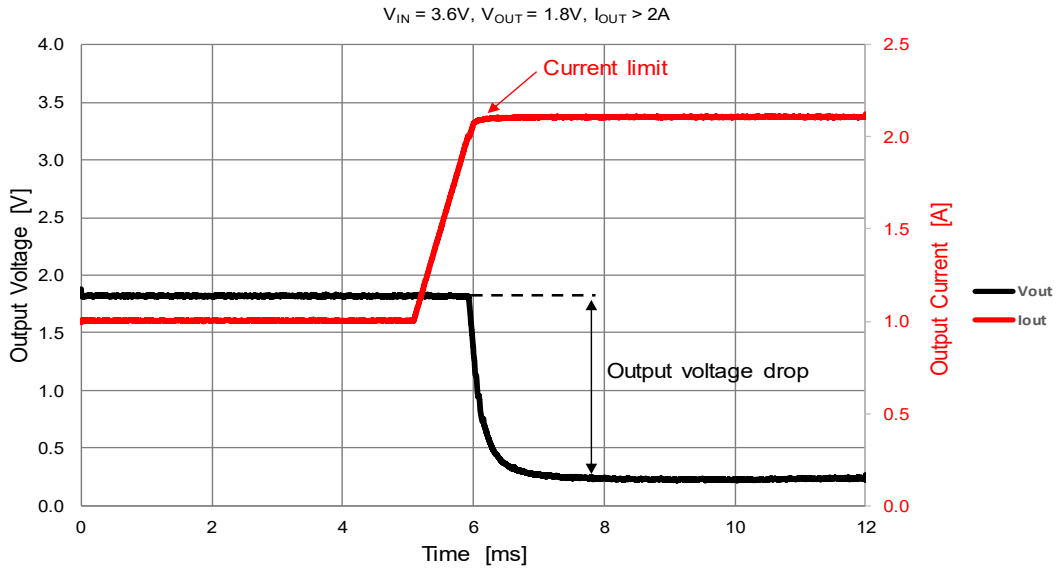

Short Circuit Protection (SCP)

When the 171010550 MagI³C MicroModule experiences a short-circuit condition at the output it will limit the current, typically to 2.2A, until the thermal protection circuit shuts the module off. If the short-circuit condition is removed, normal switching operation will begin if the module temperature is not exceeding the thermal shutdown threshold.

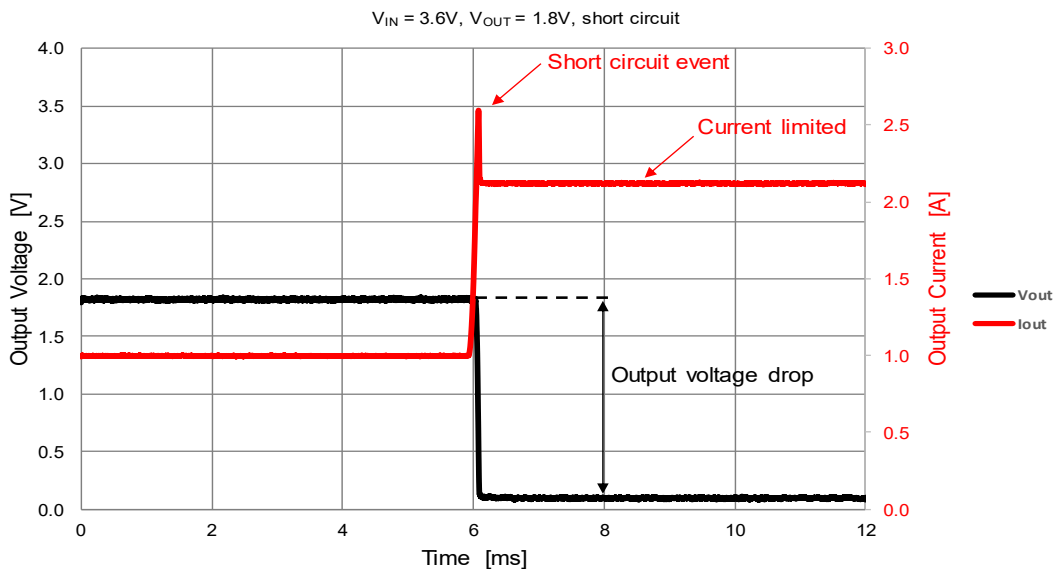

Over Temperature Protection (OTP)

Thermal protection helps prevent catastrophic failures due to accidental device overheating. The junction temperature of the 171010550 MagI³C MicroModule should not be allowed to exceed its maximum ratings. Thermal protection is implemented by an internal thermal shutdown circuit, which activates when the junction temperature reaches 160°C (typ). Under the thermal shutdown condition both MOSFETs remain off causing V_{OUT} to drop. When the junction temperature falls below 150°C the internal soft-start is released, V_{OUT} rises smoothly, and normal operation resumes.

Input Undervoltage Lockout (UVLO)

The device incorporates input undervoltage lockout (UVLO) to protect from unexpected behavior at input voltages below the recommended values. The thresholds of the UVLO are indicated in the ELECTRICAL SPECIFICATIONS on page 5.

Soft-Start

The 171010550 MagI³C MicroModule implements an internal soft-start in order to limit the inrush current and avoid output voltage overshoot during start-up. The typical duration of the soft-start is around 100µs (see figure below).

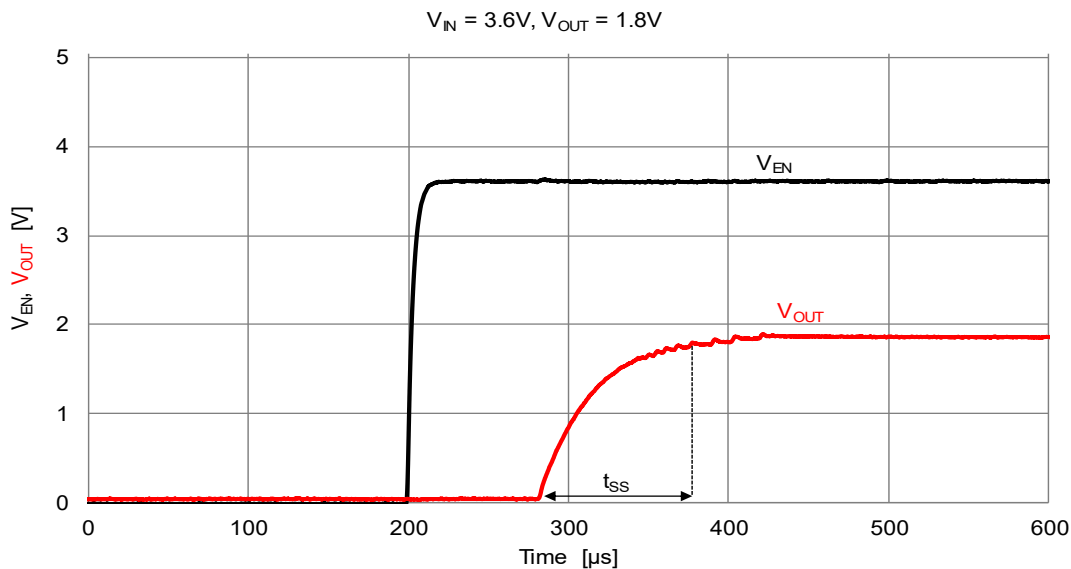

Enable

The 171010550 MagI³C MicroModule is enabled by setting the pin EN high. After setting EN high the module prepares for operation, a process which takes roughly 2ms. Once prepared, the module begins switching and the internal soft-start regulates the output voltage rise until the desired output voltage is met allowing normal operation to take place.

LAYOUT RECOMMENDATION

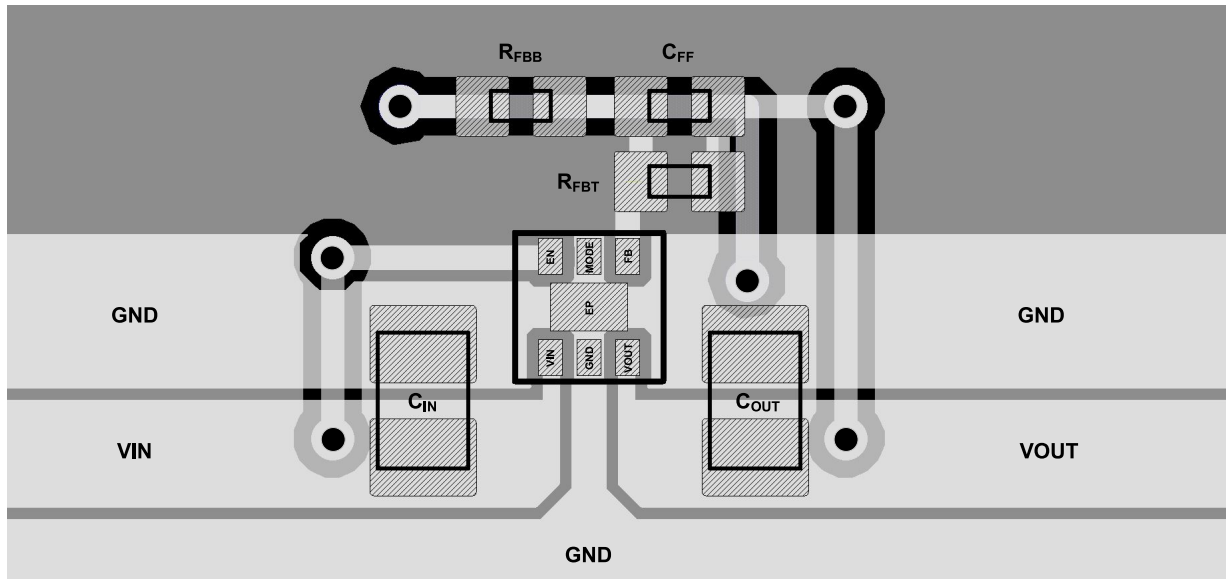

The picture above shows a possible layout for the 171010550 MagI³C MicroModule. Nevertheless, some recommendations should be followed when designing the layout:

1. The input and output capacitors should be placed as close as possible to the VIN and VOUT pins of the device.
2. The feedback resistor divider should be placed as close as possible to the FB pin.
3. Pins 5 and 2 (EN and MODE respectively) must be always connected to either VIN or ground and they cannot be left floating (an example is shown in the layout depicted above, where EN and MODE pins are respectively connected to VIN and ground).
4. Avoid placing vias in any of the pads for the module. Due to the small size of the pads, significant amounts of solder can be pulled through the vias during heating, resulting in incomplete connections between the module and board. Therefore, vias placed near the module's pads should either be plugged or covered in solder mask.

EVALUATION BOARD SCHEMATIC

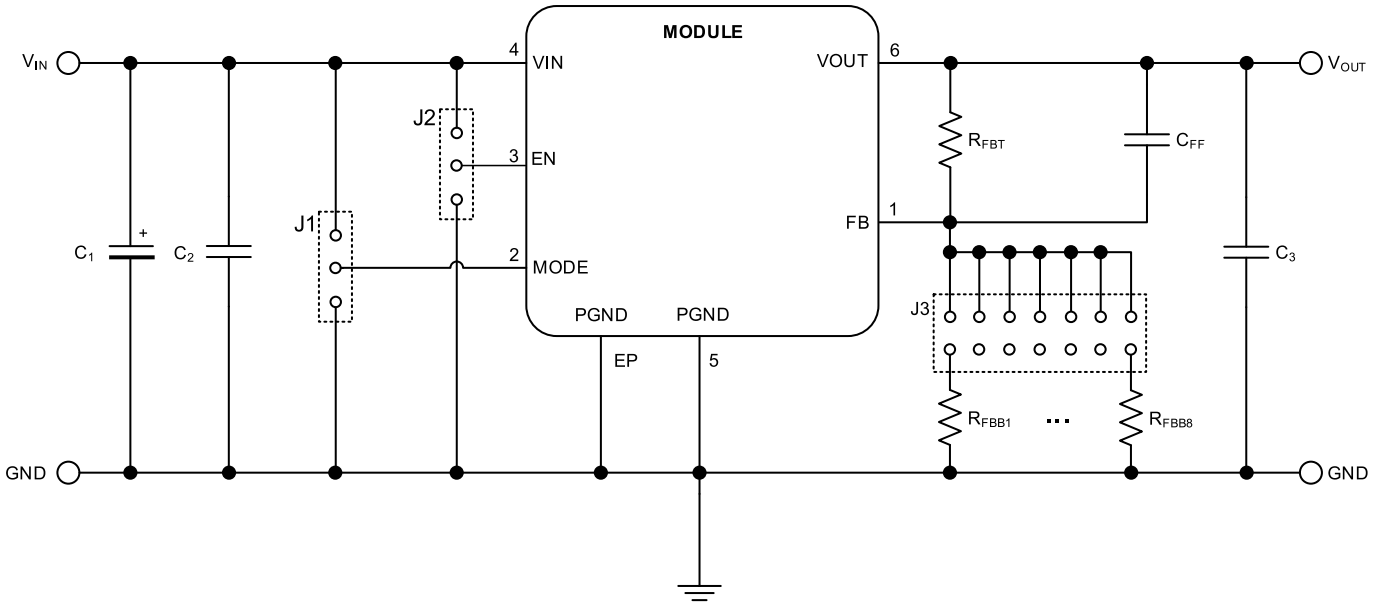

Designator	Description	Quantity	Order Code	Manufacturer
U1	MagI ³ C MicroModule	1	171010550	WE
C ₁	Aluminum polymer capacitor 220μF/10V	1	875105244013	WE
C ₂	Ceramic chip capacitor 4.7μF/16V X5R, 0805	1	885012107018	WE
C ₃	Ceramic chip capacitor 10μF/16V X5R, 0805	1	885012107014	WE
	Ceramic chip capacitor 10μF/10V X5R, 0805(*)	1	885012005010	WE
C _{ff}	Ceramic chip capacitor 22pF/10V NP0, 0402	1	885012005009	WE
R _{FBT}	100kΩ	1		
R _{FBB} Set V _{OUT} by jumper	open for V _{OUT} = 0.8V	1		
	402 kΩ for V _{OUT} = 1.0V	1		
	200 kΩ for V _{OUT} = 1.2V	1		
	115 kΩ for V _{OUT} = 1.5V	1		
	80.6 kΩ for V _{OUT} = 1.8V	1		
	47 kΩ for V _{OUT} = 2.5V	1		
	32.4 kΩ for V _{OUT} = 3.3V	1		
	To be soldered for adjustable output voltage. See Equation 1	n.p.		
J1, J2		2	61300311121	Würth Elektronik
J3	Jumper for output voltage selection. Only one resistor should be selected at a time	1	61301621121	Würth Elektronik

(*) alternative recommended part

HANDLING RECOMMENDATIONS

1. The power module is classified as MSL3 (JEDEC Moisture Sensitivity Level 3) and requires special handling due to moisture sensitivity (JEDEC J-STD033).
2. The parts are delivered in a sealed bag (Moisture Barrier Bags = MBB) and should be processed within one year.
3. When opening the moisture barrier bag check the Humidity Indicator Card (HIC) for color status. Bake parts prior to soldering in case indicator color has changed according to the notes on the card.
4. Parts must be processed after 168 hour (7 days) of floor life. Once this time has been exceeded, bake parts prior to soldering per JEDEC J-STD033 recommendation.

SOLDER PROFILE

1. Only Pb-Free assembly is recommended according to JEDEC J-STD020.
2. Measure the peak reflow temperature of the MagI³C power module in the middle of the top view.
3. Ensure that the peak reflow temperature does not exceed 235°C ±5°C as per JEDEC J-STD020.
4. The reflow time period during peak temperature of 235°C ±5°C must not exceed 20 seconds.
5. Reflow time above liquidus (217°C) must not exceed 60 seconds.
6. Maximum ramp up is rate 3°C per second
7. Maximum ramp down rate is 3°C per second
8. Reflow time from room (25°C) to peak must not exceed 8 minutes as per JEDEC J-STD020.
9. Maximum numbers of reflow cycles is two.
10. For minimum risk, solder the module in the last reflow cycle of the PCB production.
11. For soldering process please consider lead material copper (Cu) and lead finish tin (Sn).
12. For solder paste use a standard SAC Alloy such as SAC 305, type 3 or higher.
13. Below profile is valid for convection reflow only
14. Other soldering methods (e.g.vapor phase) are not verified and have to be validated by the customer on his own risk

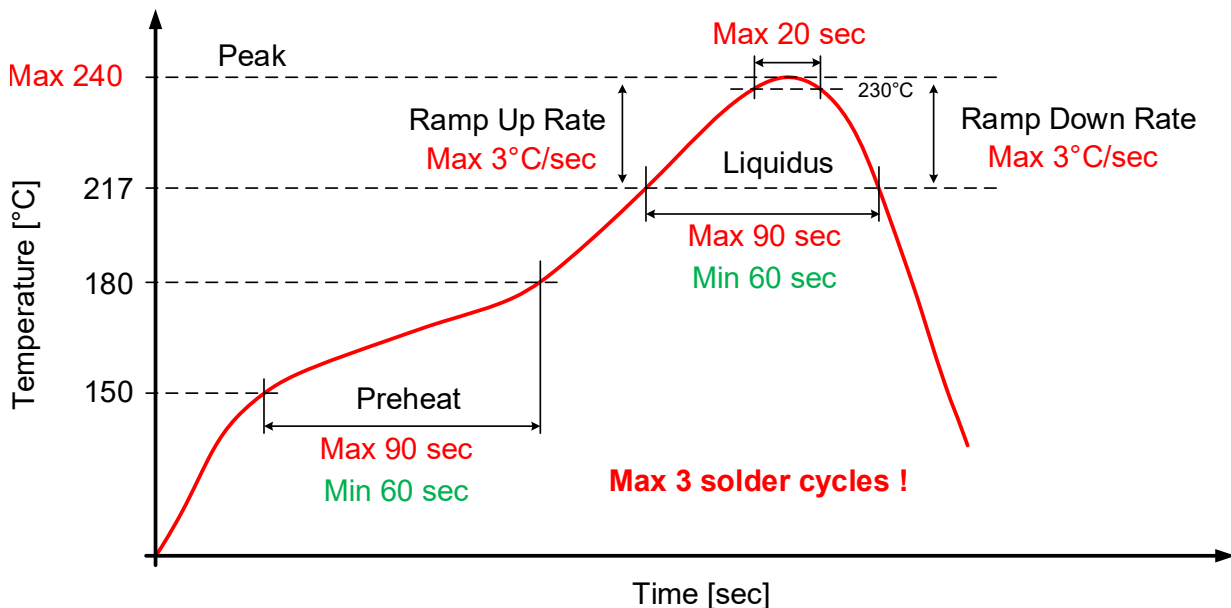

PHYSICAL DIMENSIONS

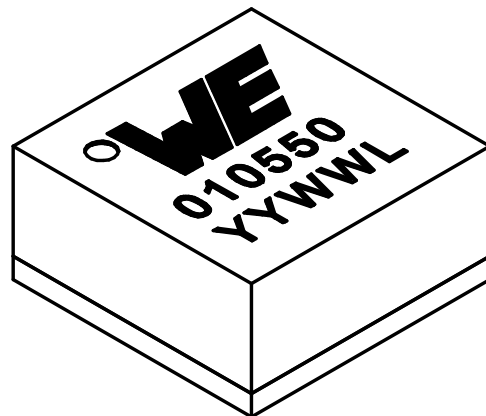
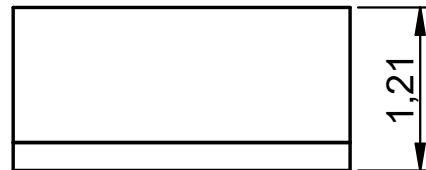
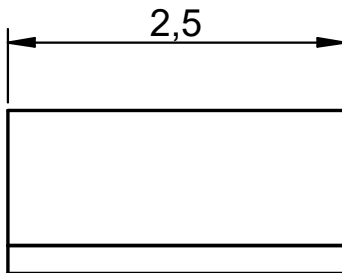
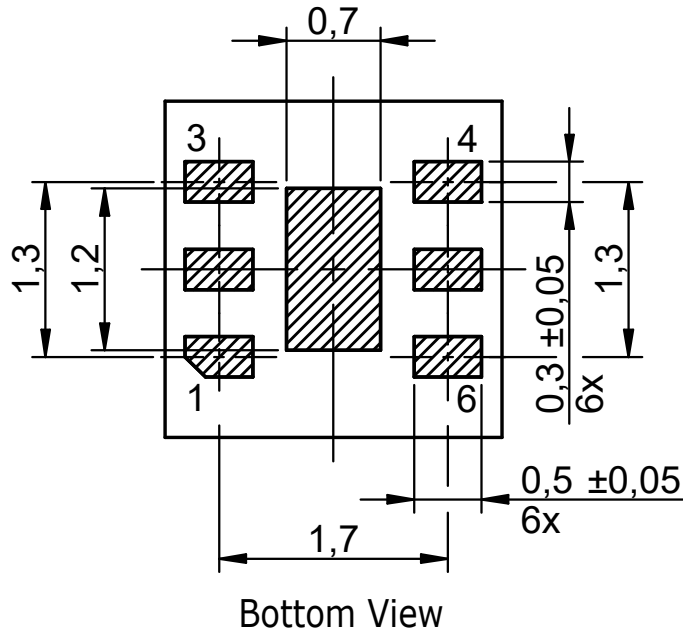

All dimensions in mm
Tolerances ±0.1mm unless otherwise indicated

EXAMPLE LANDPATTERN

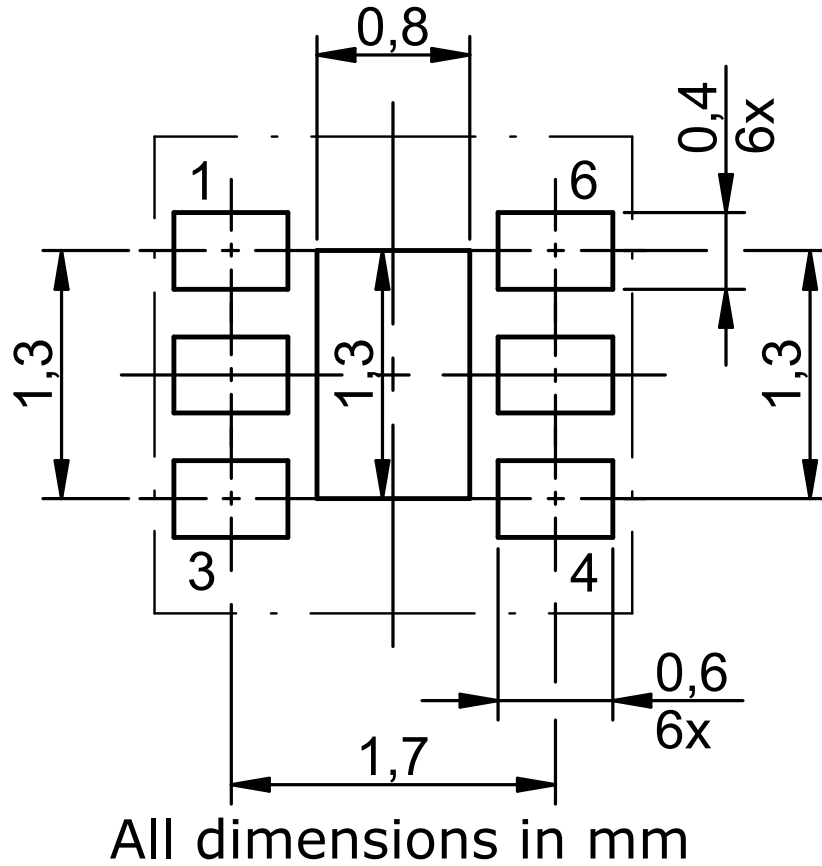

PACKAGING

Reel (mm)

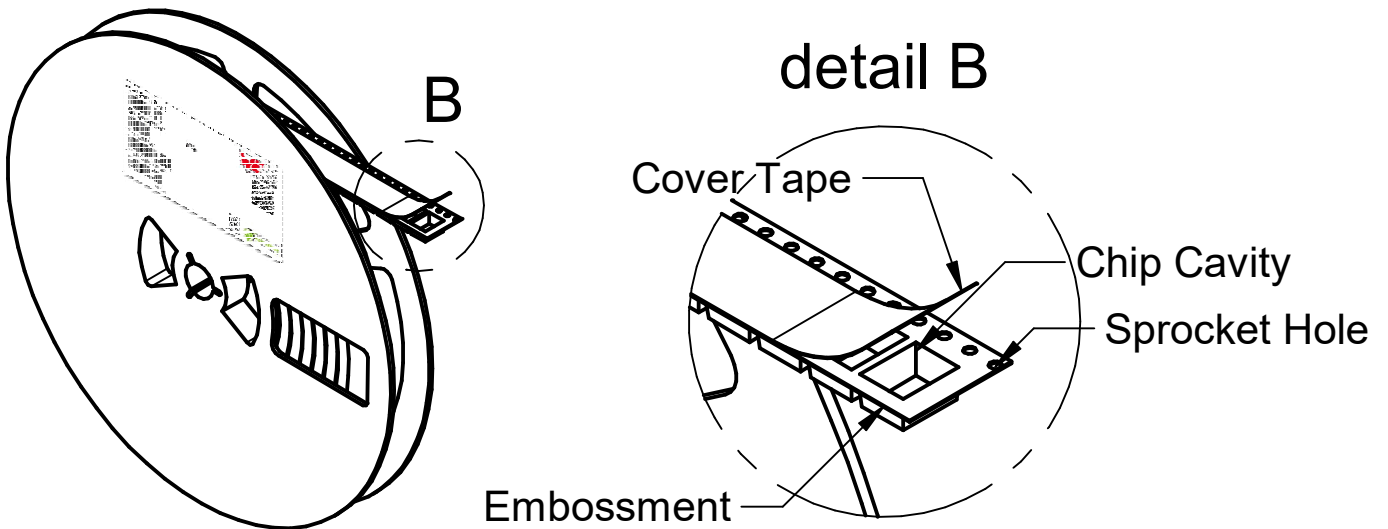
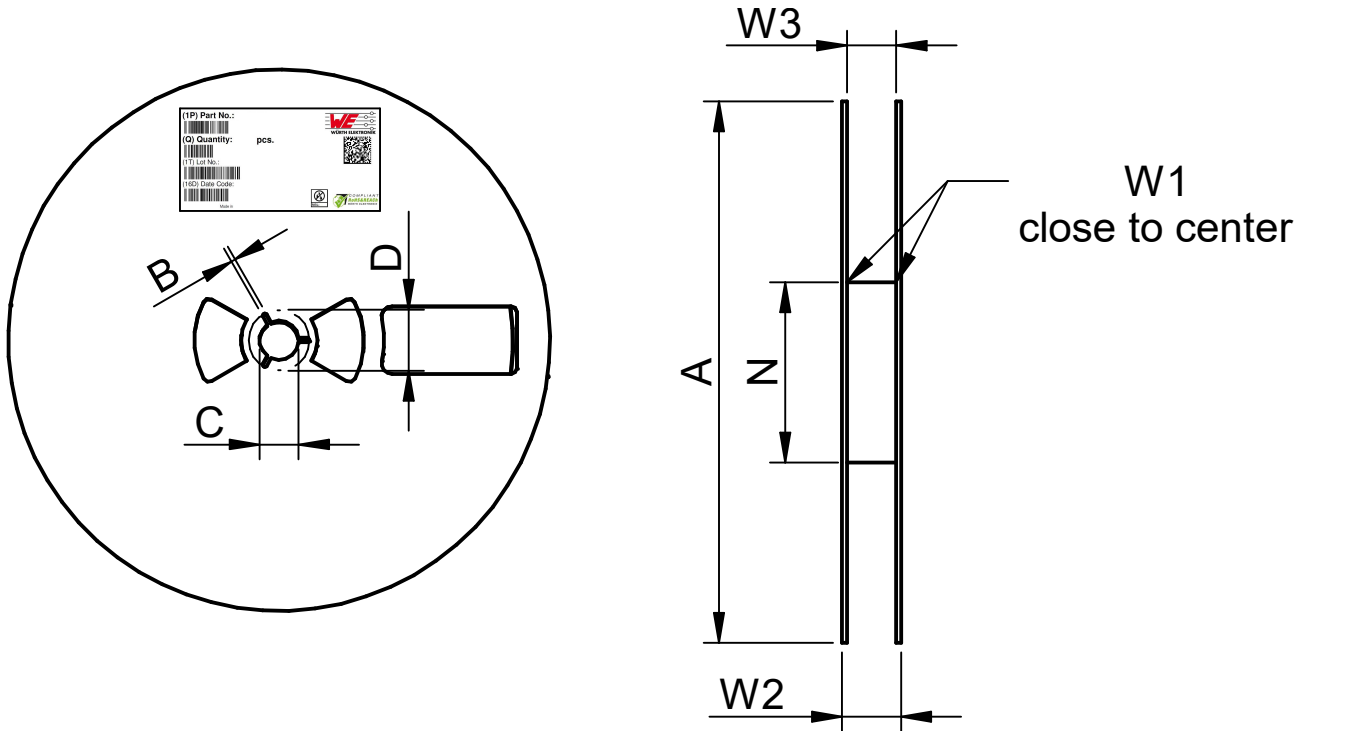

A	B	C	D	N	W1	W2	W3	W3	Material
±1.0	±0.5	±0.5	Min.	±0.5	±2.0	Max.	Min.	Max.	
178.00	2.20	13.00	20.20	60.00	12.40	18.40	11.90	15.40	Polystyrene

Tape (mm)

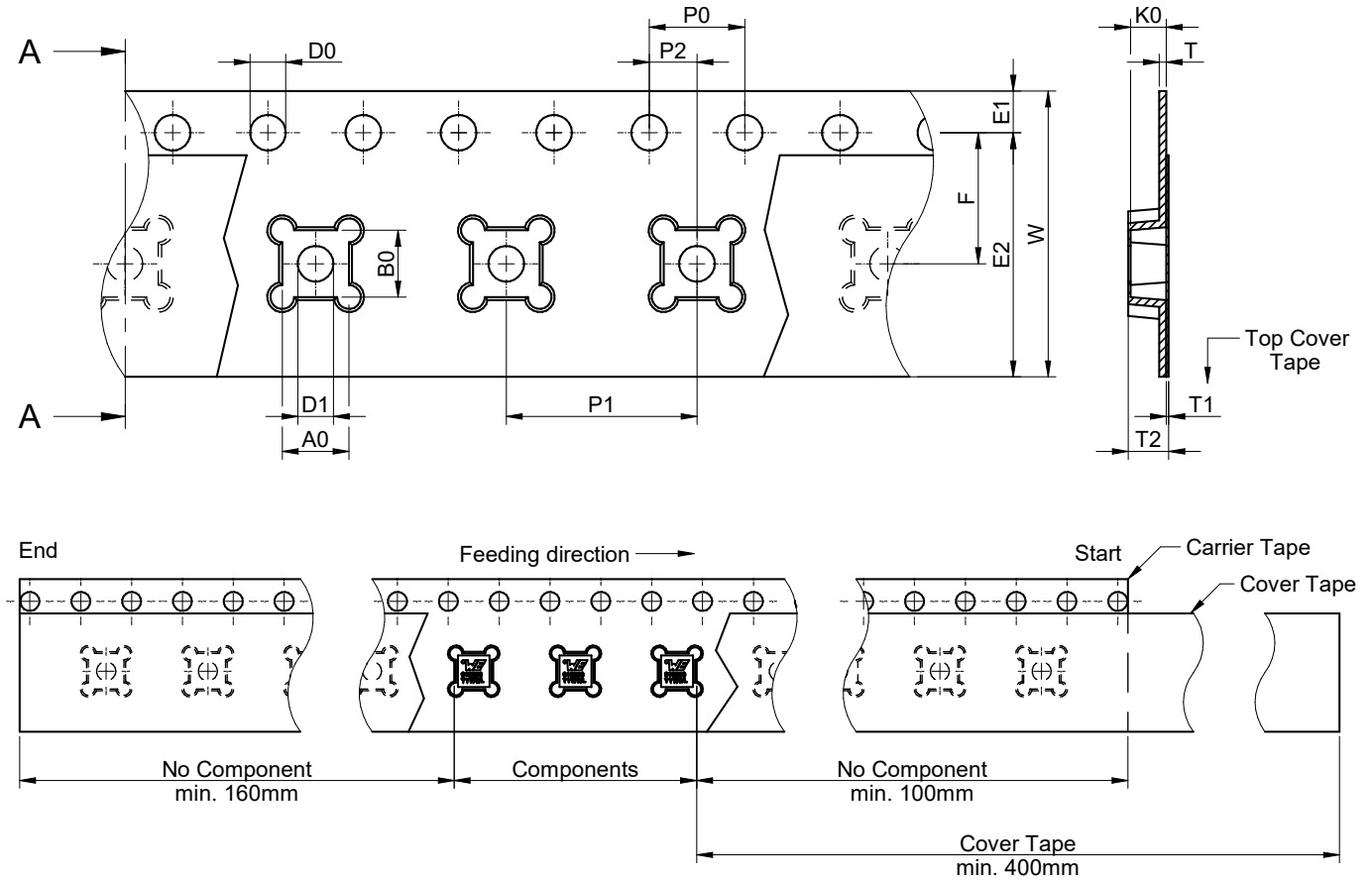

Tape Type	A0	B0	W	T	T1	T2	K0	P0	P1	P2	D0	D1	E1	E2	F	Material
	±0.1	±0.1	±0.3	±0.05			±0.1	±0.1	±0.1	±0.05	Max.	Min.	±0.1	Min.	±0.05	
2a	2.8	2.8	12	0.3	0.1		1.5	4	8	2	1.5	1.5	1.75	10.25		Polystyrene

DOCUMENT HISTORY

Revision	Date	Description	Comment
1.0	July 2019	Initial data sheet release	
2.0	November 2021	PCN	<p>Würth Elektronik has defined the maximum allowable output capacitance that can be used at the output of the power module.</p> <ol style="list-style-type: none"> 1. The minimum and maximum storage temperature (page 4). 2. The junction to ambient thermal resistance (page 4). 3. The layout recommendation to improve readability and recommended practices (page 36). 4. The solder handling instructions (no change to actual profile) (page 38). 5. The package information (page 7). 6. The evaluation board bill of material to reflect the evaluation board (page 37). 7. The cautions and warnings of the data sheet (page 44). 8. The format of the data sheet to improve readability of the document.
2.1	March 2022	Minor formatting change	Changed output voltage and feedback resistor table format in Step 1 of the Design Flow section.
3.0	May 2022	PCN	<ol style="list-style-type: none"> 1. The maximum absolute rating maximum limit for VOUT, EN, FB and MODE (page 4). 2. The parameter description for the MODE absolute maximum rating (page 4). 3. The quiescent current values in the electrical specifications (page 6). 4. The date for the release of version 2.0 in the document history (page 43).

CAUTIONS AND WARNINGS

The following conditions apply to all goods within the product series of MagI³C of Würth Elektronik eiSos GmbH & Co. KG:

General:

- This electronic component is designed and manufactured for use in general electronic equipment.
- Würth Elektronik must be asked for written approval (following the PPAP procedure) before incorporating the components into any equipment in fields such as military, aerospace, aviation, nuclear control, submarine, transportation (automotive control, train control, ship control), transportation signal, disaster prevention, medical, public information network, etc. where higher safety and reliability are especially required and/or if there is the possibility of direct damage or human injury.
- Electronic components that will be used in safety-critical or high-reliability applications, should be pre-evaluated by the customer.
- The component is designed and manufactured to be used within the datasheet specified values. If the usage and operation conditions specified in the datasheet are not met, the component may be damaged or dissolved.
- Do not drop or impact the components as material of the body, pins or termination may flake apart.
- Würth Elektronik products are qualified according to international standards, which are listed in each product reliability report. Würth Elektronik does not warrant any customer qualified product characteristics beyond Würth Elektronik's specifications, for its validity and sustainability over time.
- All technical specifications for standard products also apply to customer specific products.
- Customer acknowledges and agrees that it is solely responsible for compliance with all legal, regulatory and safety-related requirements concerning its products, and any use of Würth Elektronik eiSos GmbH & Co. KG components in its applications, notwithstanding any applications-related information or support that may be provided by Würth Elektronik eiSos GmbH & Co. KG. Customer represents and agrees that it has all the necessary expertise to create and implement safeguards which anticipate dangerous consequences of failures, monitor failures and their consequences lessen the likelihood of failures that might cause harm and take appropriate remedial actions. Customer will fully indemnify Würth Elektronik eiSos and its representatives against any damages arising out of the use of any Würth Elektronik eiSos GmbH & Co. KG components in safety-critical applications.

Product specific:**Soldering:**

- The solder profile must comply with the technical product specifications. All other profiles will void the warranty.
- All other soldering methods are at the customer's own risk.

Cleaning and Washing:

- Residual washing varnish agent that is used during the production to clean the application might change the characteristics of the body, pins or termination. The washing varnish agent may have a negative effect on the long term function of the component.
- Using a brush during the cleaning process may break the component. Therefore, we do not recommend using a brush during the PCB cleaning process.

Potting and Coating:

- If the component is potted in the customer application, the potting material might shrink or expand during and after hardening. Shrinking could lead to an incomplete seal, allowing contaminants into the component. Expansion could damage the components or parts of it. We recommend a manual inspection after potting to avoid these effects.
- Conformal coating may affect the product performance.

Storage Conditions:

- A storage of Würth Elektronik products for longer than 12 months is not recommended. Within other effects, the terminals may suffer degradation, resulting in bad solderability. Therefore, all products shall be used within the period of 12 months based on the day of shipment.
- Do not expose the components to direct sunlight.
- The storage conditions in the original packaging are defined according to DIN EN 61760-2.
- For a moisture sensitive component, the storage condition in the original packaging is defined according to IPC/JEDEC-J-STD-033. It is also recommended to return the component to the original moisture proof bag and reseal the moisture proof bag again.
- ESD prevention methods need to be followed for manual handling and processing by machinery.
- The storage conditions stated in the original packaging apply to the storage time and not to the transportation time of the components.

Packaging:

- The packaging specifications apply only to purchase orders comprising whole packaging units. If the ordered quantity exceeds or is lower than the specified packaging unit, packaging in accordance with the packaging specifications cannot be ensured.

Handling:

- Violation of the technical product specifications such as exceeding the absolute maximum ratings will void the warranty and also the conformance to regulatory requirements.
- The edge castellation is designed and made for prototyping, i.e. hand soldering purposes, only.
- The applicable country regulations and specific environmental regulations must be observed.
- Do not disassemble the component. Evidence of tampering will void the warranty.
- The temperature rise of the component must be taken into consideration. The operating temperature is comprised of ambient temperature and temperature rise of the component. The operating temperature of the component shall not exceed the maximum temperature specified.
- Direct mechanical impact to the component must be prevented as the material of the body, pins or termination could flake or, in the worst case, could break. As these devices are sensitive to electrostatic discharge, proper IC Handling Procedures must be followed.

These cautions and warnings comply with the state of the scientific and technical knowledge and are believed to be accurate and reliable. However, no responsibility is assumed for inaccuracies or incompleteness.

IMPORTANT NOTES

General Customer Responsibility

Some goods within the product range of Würth Elektronik eiSos GmbH & Co. KG contain statements regarding general suitability for certain application areas. These statements about suitability are based on our knowledge and experience of typical requirements concerning the areas, serve as general guidance and cannot be estimated as binding statements about the suitability for a customer application. The responsibility for the applicability and use in a particular customer design is always solely within the authority of the customer. Due to this fact it is up to the customer to evaluate, where appropriate to investigate and decide whether the device with the specific product characteristics described in the product specification is valid and suitable for the respective customer application or not. Accordingly, the customer is cautioned to verify that the datasheet is current before placing orders.

Customer Responsibility Related to Specific, in Particular Safety-Relevant, Applications

It has to be clearly pointed out that the possibility of a malfunction of electronic components or failure before the end of the usual lifetime cannot be completely eliminated in the current state of the art, even if the products are operated within the range of the specifications. In certain customer applications requiring a very high level of safety and especially in customer applications in which the malfunction or failure of an electronic component could endanger human life or health it must be ensured by most advanced technological aid of suitable design of the customer application that no injury or damage is caused to third parties in the event of malfunction or failure of an electronic component.

Best Care and Attention

Any product-specific notes, warnings and cautions must be strictly observed. Any disregard will result in the loss of warranty.

Customer Support for Product Specifications

Some products within the product range may contain substances which are subject to restrictions in certain jurisdictions in order to serve specific technical requirements. Necessary information is available on request. In this case the field sales engineer or the internal sales person in charge should be contacted who will be happy to support in this matter.

Product R&D

Due to constant product improvement product specifications may change from time to time. As a standard reporting procedure of the Product Change Notification (PCN) according to the JEDEC-Standard we inform about minor and major changes. In case of further queries regarding the PCN, the field sales engineer or the internal sales person in charge should be contacted. The basic responsibility of the customer as per Section 1 and 2 remains unaffected.

Product Life Cycle

Due to technical progress and economical evaluation we also reserve the right to discontinue production and delivery of products. As a standard reporting procedure of the Product Termination Notification (PTN) according to the JEDEC-Standard we will inform at an early stage about inevitable product discontinuance. According to this we cannot guarantee that all products within our product range will always be available. Therefore it needs to be verified with the field sales engineer or the internal sales person in charge about the current product availability expectancy before or when the product for application design-in disposal is considered. The approach named above does not apply in the case of individual agreements deviating from the foregoing for customer-specific products.

Property Rights



All the rights for contractual products produced by Würth Elektronik eiSos GmbH & Co. KG on the basis of ideas, development contracts as well as models or templates that are subject to copyright, patent or commercial protection supplied to the customer will remain with Würth Elektronik eiSos GmbH & Co. KG. Würth Elektronik eiSos GmbH & Co. KG does not warrant or represent that any license, either expressed or implied, is granted under any patent right, copyright, mask work right, or other intellectual property right relating to any combination, application, or process in which Würth Elektronik eiSos GmbH & Co. KG components or services are used.

General Terms and Conditions







Unless otherwise agreed in individual contracts, all orders are subject to the current version of the "General Terms and Conditions of Würth Elektronik eiSos Group", last version available at www.we-online.com.

Looking for pricing, stock, or lifecycle information?

Click below to explore more details on WIN SOURCE:

-  [View 171010550 on WIN SOURCE](#)
-  [Wurth Electronics Inc Information](#)

Optimize Your Supply Chain with WIN SOURCE Solutions

-  Global Sourcing Solution
-  Obsolete Management
-  Cost Control Management
-  Shortage Management
-  Alternative Solution
-  Excess Inventory Management