



**THE DATASHEET OF  
G23270006**



# PSE Technology Corporation

## SPECIFICATION FOR APPROVAL

CUSTOMER \_\_\_\_\_

NOMINAL FREQUENCY 32.768 KHz



PRODUCT TYPE G2 Series Cylinder Through Hole Quartz Crystal

SPEC. NO. ( P/N ) G23270006

CUSTOMER P/N \_\_\_\_\_

ISSUE DATE Mar.24,2011

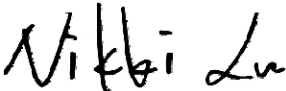
VERSION D

APPROVED	PREPARED	QA
		
APPROVED BY CUSTOMER :		AVL Status
Please return one copy with approval to PSE-TW		

### PSE Technology Corporation

No.2, Tzu-Chiang 5th Rd, Chung Li Industrial Park,  
 Chung Li City, Taoyuan County, Taiwan (R.O.C.)  
 TEL: 886-3-451-8888  
 FAX: 886-3-461-3865  
<http://www.saronix-ecera.com.tw>

- \*RoHS Exception
- \*HF-Halogen Free
- \*REACH Compliant



# G2 Series 2.0x6.0mm Cylinder Through Hole Quartz Crystal

## G23270006

VER. D 24-Mar-11

### ELECTRICAL SPECIFICATIONS

SRe Part Number : G23270006

Parameters	Symbol	Specifications	Units	Notes
Nominal Frequency	Fn	32.768	KHz	
Mode of Oscillation	MO	Fundamental		+2° X-Cut
Drive Level	DL	1	$\mu W$	Max.
Load Capacitance	CL	6	pF	Typical
Frequency Tolerance	FT	$\pm 20$	ppm	at 25°C $\pm 5^\circ C$
Operating Temperature Range	TR	-10~60	°C	
Equivalent Series Resistance	ESR	40	K $\Omega$	Max.
Temperature Coefficient	K	-0.035	ppm/°C <sup>2</sup>	Typical
Aging		$\pm 3$	ppm	Max 1st year
Insulation Resistance		500	M $\Omega$	at DC 100V $\pm 15V$

### Reliability ( Mechanical and Environmental Endurance )

No.	Test Items	Test Method and Condition	Requirements
1	Vibration	(1) Vibration Frequency: 10 to 55Hz (2) Vibration Amplitude: 1.5mm (3) Cycle Time: 1-2min(10-55-10Hz) (4) Direction: X.Y.Z (5) Duration: 2h/each direction	Frequency Change: $\pm 10$ ppm Max. Resistance Change: 5kohm Max.
2	Shock	3 Times free drop from 75cm height to hard wooden board of thickness more than 30mm	Frequency Change: $\pm 10$ ppm Max. Resistance Change: 5kohm Max.
3	Leakage	Put crystal units into a hermetic container and Helium for 0.5-0.6Mpa, and keep it for 1h; Check the leakage by a Helium leak detector	Leakage: $1 \times 10^{-8}$ Pa·m <sup>3</sup> /s Max.



# G2 Series 2.0x6.0mm Cylinder Through Hole Quartz Crystal

**G23270006**

VER. D 24-Mar-11

4	Lead Strength (DIP)	The crystal lead with the 0.9kg(9N) power (keep it for 30s±5s) and bend the crystal lead 90° with 0.45kg power and two times	The crystal lead is not abnormality
5	High Temperature Endurance	The crystal units shall be put in somewhere for 2 hrs at temperature of 85°C ±2°C, then keep it for 1 to 2 hrs under room temperature.	Frequency Change: ±10ppm Max. Resistance Change:5kohm Max.
6	Low Temperature Endurance	The crystal units shall be put in somewhere for 2 hrs at temperature of -25°C, then keep it for 1 to 2 hrs under room temperature.	
7	Humidity Endurance	The crystal units shall be put in somewhere at 40°C in relative humidity of 90-95% for 48 hrs, then keep it for one or two hours under room temperature.	
8	Temperature Cycle	Temperature shift from low(-40°C) to high(100°C, keep 30 mins), satisfy high(100°C) to low(-40°C, keep 30 mins), then go up to room temperature for 5 cycles.	
10	Salt Spray Test	Put the crystal units in the salt spray room (salt density: 5%) at the temperature of 35°C for 96 hrs. Then clean it with water and dry its surface.	The appearance shall has no abnormality and soldering is good. Frequency Change: ±10ppm Max. Resistance Change:5kohm Max.

# G2 Series 2.0x6.0mm Cylinder Through Hole Quartz Crystal

G23270006

VER. D 24-Mar-11

## MARKING

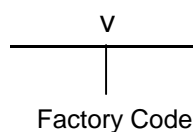
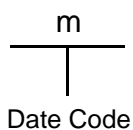
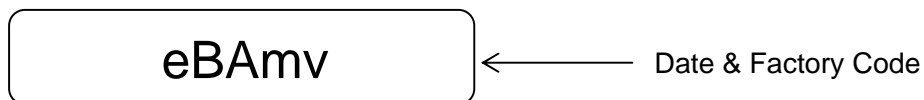

## DIMENSIONS (Unit:mm)

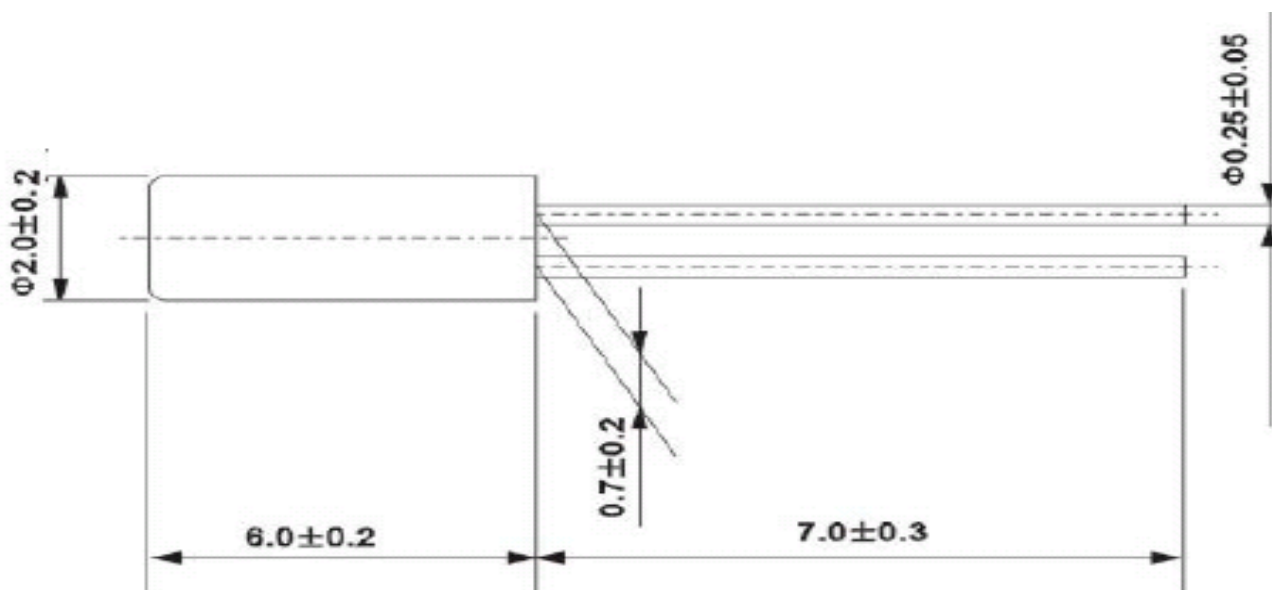

# G2 Series 2.0x6.0mm Cylinder Through Hole Quartz Crystal

G23270006

VER. D 24-Mar-11

## PACKING

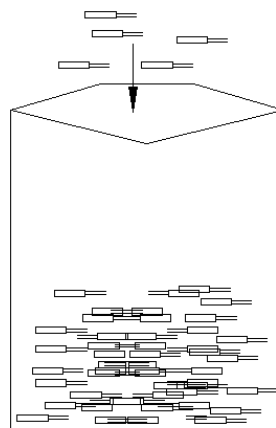
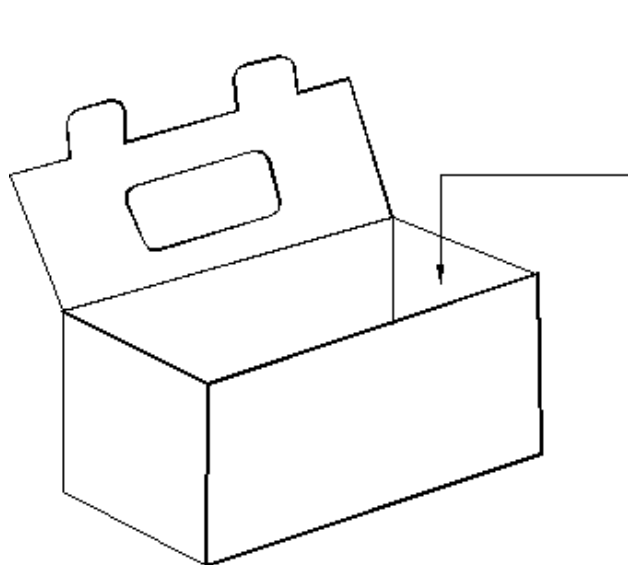

Quantity for Each Bag : 1000 pcs

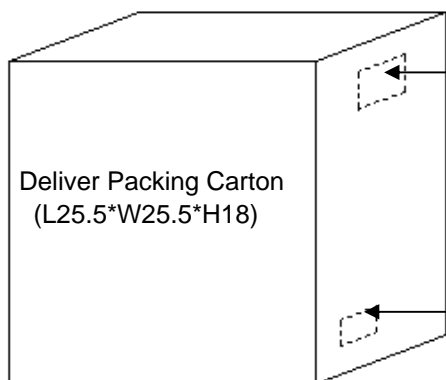
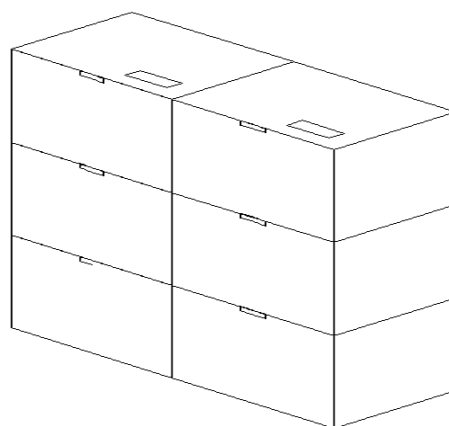



Storeroom Label

Green Qualified Label

## Looking for pricing, stock, or lifecycle information?

Click below to explore more details on WIN SOURCE:

-  [View G23270006 on WIN SOURCE](#)
-  [Diodes Incorporated Information](#)

## Optimize Your Supply Chain with WIN SOURCE Solutions

-  Global Sourcing Solution
-  Obsolete Management
-  Cost Control Management
-  Shortage Management
-  Alternative Solution
-  Excess Inventory Management