



**THE DATASHEET OF
1433900000**



RJ45C5 S1V 2.7N4N RL

Weidmüller Interface GmbH & Co. KG

Klingenbergstraße 26

D-32758 Detmold

Germany

www.weidmueller.com

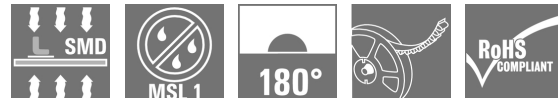

The product range encompasses the following designs:

- 90°, lying (horizontal) and 180°, standing (vertical)
- latch up / latch down
- THT, THR or SMD soldering processes
- Wide range of different design types, also with integrated LEDs and shield contact tabs
- Performance category Cat. 3 to Cat. 6
- Packed either in a tray (TY) or on a roll (tape-on-reel, RL)
- Compatible with modular RJ45 connector according to ANSI / TIA-1096-A and IEC 60603
- Dielectric strength ≥ 1500 V AC RMS (2250 V AC peak value) according to IEEE 802.3
- Dielectric strength ≥ 1500 V AC (peak value) or ≥ 1500 V DC according to IEC 60603

Properties and advantages:

- Extended temperature range of -40°C to $+85^{\circ}\text{C}$ for maximum performance
- Reinforced gold layer ($30\mu\text{m}$) for improved corrosion protection
- At least 0.3mm stand-off ensures a perfect soldering result

General ordering data

Version	PCB plug-in connector, RJ45 jacks, Cat. 5 , SMD solder connection, 180°, Shield tabs: none, 30...80 μm Ni / ≥ 30 μm Au , LED: No, Number of poles: 8, Tape
Order No.	1433900000
Type	RJ45C5 S1V 2.7N4N RL
GTIN (EAN)	4050118238587
Qty.	300 pc(s).
Packaging	Tape

RJ45C5 S1V 2.7N4N RL

Weidmüller Interface GmbH & Co. KG

Klingenbergstraße 26

D-32758 Detmold

Germany

www.weidmueller.com

Technical data

Dimensions and weights

Depth	20.05 mm	Depth (inches)	0.789 inch
Height	13.2 mm	Height (inches)	0.52 inch
Height of lowest version	13.2 mm	Width	16.1 mm
Width (inches)	0.634 inch	Net weight	3.467 g

System specifications

Category	Cat. 5	Coplanarity:	100 µm
LED	No	Mounting onto the PCB	SMD solder connection
Number of poles	8	Number of solder pins per pole	1
Outgoing elbow	180°	Performance-Category	Cat. 5
Pitch in inches (P)	0.05 inch	Pitch in mm (P)	1.27 mm
Product family	OMNIMATE Data - RJ45 modular jack	Protection degree	IP20
Shield surface	nickel-plated	Shield tabs	none
Shielding	Yes	Shielding material	Copper alloy
Solder pin length (l)	3.5 mm	Soldering process	Reflow soldering, Manual soldering
Type of connection	Socket connector	Wiring	8-core

Electrical properties

Dielectric strength, contact / contact	1000 V DC	Dielectric strength, contact / shield	1500 V DC
Rated current	1.5 A	Rated voltage	125 V

Standards

Connector standard	IEC 60603-7-5 1
--------------------	-----------------

Material data

Insulating material	PA 9T	Colour	black
Colour chart (similar)	RAL 9011	Insulating material group	II
Comparative Tracking Index (CTI)	≥ 500	Moisture Level (MSL)	1
UL 94 flammability rating	V-0	Contact base material	Phosphorus bronze
Contact surface	Gold over nickel	Layer structure of solder connection	30...80 µm Ni / ≥ 30 µm Sn
Layer structure of plug contact	30...80 µm Ni / ≥ 30 µm Au	Storage temperature, min.	-40 °C
Storage temperature, max.	85 °C	Operating temperature, min.	-40 °C
Operating temperature, max.	85 °C		

Packing

Packaging	Tape	VPE length	332 mm
VPE width	332 mm	VPE height	53 mm
Tape reel diameter Ø (A)	330 mm	Surface resistance	Rs = 10 ⁹ - 10 ¹² Ω

Classifications

ETIM 6.0	EC002637	ETIM 7.0	EC002637
ETIM 8.0	EC002637	ECLASS 9.0	27-44-04-02
ECLASS 9.1	27-44-04-02	ECLASS 10.0	27-44-04-02
ECLASS 11.0	27-46-02-01		

RJ45C5 S1V 2.7N4N RL

Weidmüller Interface GmbH & Co. KG
Klingenbergstraße 26
D-32758 Detmold
Germany

www.weidmueller.com

Technical data**Approvals**

Approvals



ROHS

Conform

Downloads

Approval/Certificate/Document of
Conformity

[Certificate of Compliance](#)

Engineering Data

[CAD data – STEP](#)

User Documentation

[MAN IE GUIDE DE](#)
[MAN IE GUIDE EN](#)

Catalogues

[Catalogues in PDF-format](#)

Brochures

[MB FREECONTACT EN](#)
[FL FIELDWIRING EN](#)
[PI PROFINET CABLING EN](#)
[PI PROFINET CABLING EN](#)

Data sheet

RJ45C5 S1V 2.7N4N RL

Weidmüller Interface GmbH & Co. KG
Klingenbergstraße 26
D-32758 Detmold
Germany

www.weidmueller.com

Drawings

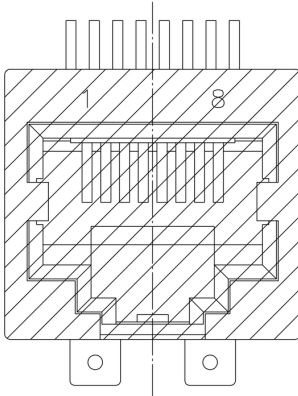

RJ45C5 S1V 2.7N4N RL

Weidmüller Interface GmbH & Co. KG
 Klingenbergstraße 26
 D-32758 Detmold
 Germany

www.weidmueller.com

Drawings

Dimensional drawing

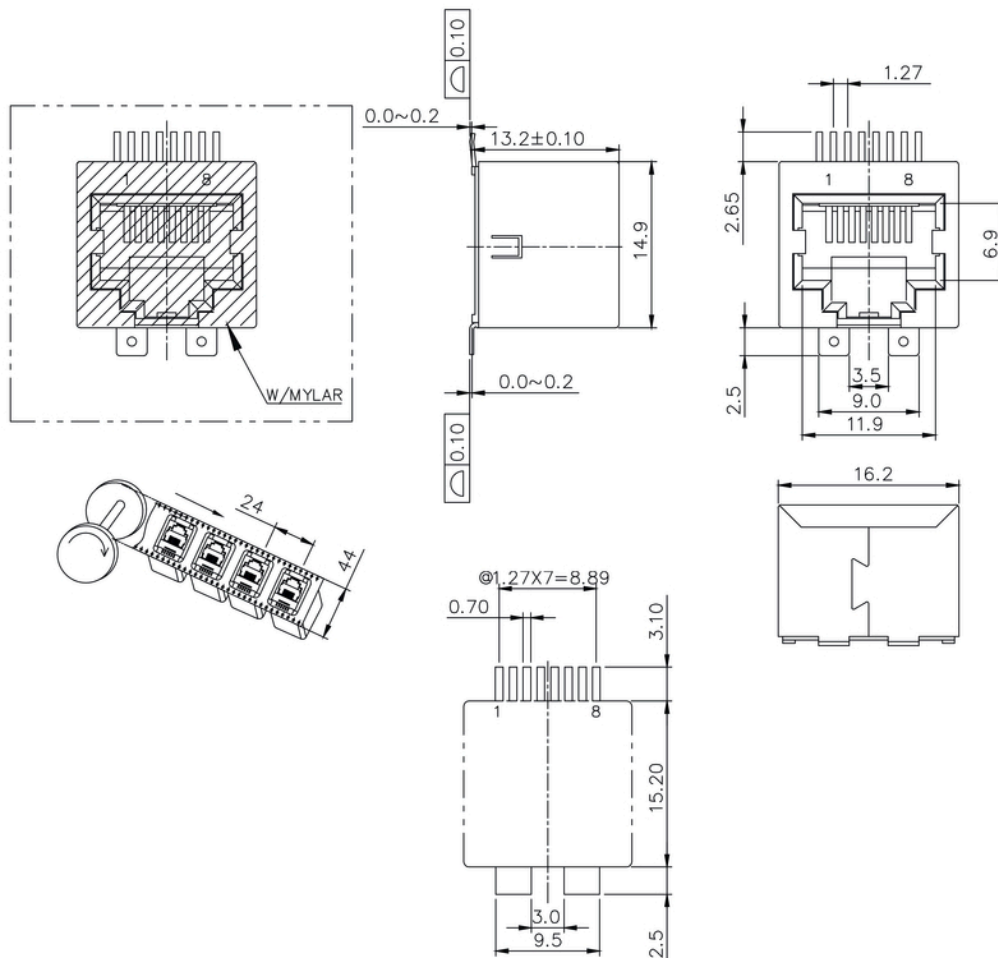

RJ45C5 S1V 2.7N4N RL

Weidmüller Interface GmbH & Co. KG
 Klingenbergstraße 26
 D-32758 Detmold
 Germany

www.weidmueller.com

Drawings

Code	Value	Description
RJ45	G1	RJ45G1
	R1	R1U
	U	U3.2
	3.2	E4
	E	4GY/GY
	4	TY
	GY/GY	
	TY	
RJ45G1 R1U 3.2E4GY/GY TY		
Packaging	TY	Tray in box (manual assembly)
	RL	Tape on Reel (automated assembly)
LED	Y/G	Yellow/Green
	G/Y	Green/Yellow (standard)
	GY/GY	Green-Yellow/Green-Yellow
	O/G	Orange/Green
	R/O	Red/Orange
 (further combinations possible)
	N	without LED
Contact surface thickness	4	1 = 3µ", 2 = 6µ", 3 = 15µ", 4 = 30µ", 5 = 50µ"
EMI tabs (ground fingers)	E	E = with EMI tabs
	N	N = without EMI tabs
Solder Pin length	3.2	3.2 mm
	1.6	1.6 mm
	D	SMD
Direction, latch style	U	Horizontal (90°, side entry), latch up
	D	Horizontal (90°, side entry), latch down
	V	Vertical (180°, top entry)
	Y	Diagonal (45°), latch up
Number of Ports	1	1 Port
	12; 14; ...	multi ports side by side, Multiport
	21; 41; ...	multi ports about each other, Multilevel
Assembly on PCB	R	Through Hole Reflow - THR
	S	Soldering process: Wave or Reflow soldering
	S	Surface Mount Technology - SMT
	T	Soldering process: Reflow soldering
	T	Through Hole Technology - THT
	T	Soldering process: Wave
Performance Category	C5	Category 5
	C6	Category 6
	C6A	Category 6A
	C5e	Category 5e
	M	10/100 Mbit
	G1	10/100/1000 Mbit
	G10	10 Gbit
	U	Unshielded
	MP	10/100 Mbit with POE
	MP+	10/100 Mbit with POE+

Legend

Recommended reflow soldering profile

Weidmüller Interface GmbH & Co. KG
 Klingenbergstraße 16
 D-32758 Detmold
 Germany
 Fon: +49 5231 14-0
 Fax: +49 5231 14-292083
 www.weidmueller.com



Reflow soldering profile

The perfect soldering profile for SMT Surface Mount Technology is one the most exiting question in SMT production. But there are more than one correct answer: The diagram of temperature-on-time is related to processing features of solder paste and to maximum load of components.

We have to consider the following parameters:

- Time for pre heating
- Maximum temperature
- Time above melting point
- Time for cooling
- Maximum heating rate
- Maximum cooling rate

We recommend a typical solder profile with associated process limits. With preheating components and board are prepared smoothly for the solder phase. Heating rate is typically $\leq +3\text{K/s}$. In parallel the solder paste is ‚activated‘. The time above melting point of 217°C the paste gets liquid and components and boards begin to connect. The maximum temperature of 245°C to 254°C should stay between 10 and 40 seconds. In the cooling phase at $\geq -6\text{K/s}$ solder is cured. Board and components cool down while avoiding cold cracks.

Mouser Electronics

Authorized Distributor

Click to View Pricing, Inventory, Delivery & Lifecycle Information:

[Weidmuller:](#)

[1433900000](#)

Looking for pricing, stock, or lifecycle information?

Click below to explore more details on WIN SOURCE:

 [View 1433900000 on WIN SOURCE](#)

 [Weidmuller Information](#)

Optimize Your Supply Chain with WIN SOURCE Solutions

-  Global Sourcing Solution
-  Obsolete Management
-  Cost Control Management
-  Shortage Management
-  Alternative Solution
-  Excess Inventory Management