



**THE DATASHEET OF  
DS90CR287SLC**



## DS90CR287/DS90CR288A +3.3V Rising Edge Data Strobe LVDS 28-Bit Channel Link - 85MHz

Check for Samples: [DS90CR287](#), [DS90CR288A](#)

### FEATURES

- 20 to 85 MHz Shift Clock Support
- 50% Duty Cycle on Receiver Output Clock
- 2.5 / 0 ns Set & Hold Times on TxINPUTS
- Low Power Consumption
- $\pm 1V$  Common-Mode Range (around +1.2V)
- Narrow Bus Reduces Cable Size and Cost
- Up to 2.38 Gbps Throughput
- Up to 297.5 Mbytes/sec Bandwidth
- 345 mV (typ) Swing LVDS Devices for Low EMI
- PLL Requires no External Components
- Rising Edge Data Strobe
- Compatible with TIA/EIA-644 LVDS Standard
- Low Profile 56-Lead TSSOP Package

### DESCRIPTION

The DS90CR287 transmitter converts 28 bits of LVCMOS/LVTTL data into four LVDS (Low Voltage Differential Signaling) data streams. A phase-locked transmit clock is transmitted in parallel with the data streams over a fifth LVDS link. Every cycle of the transmit clock 28 bits of input data are sampled and transmitted.

The DS90CR288A receiver converts the four LVDS data streams back into 28 bits of LVCMOS/LVTTL data. At a transmit clock frequency of 85 MHz, 28 bits of TTL data are transmitted at a rate of 595 Mbps per LVDS data channel. Using a 85 MHz clock, the data throughput is 2.38 Gbit/s (297.5 Mbytes/sec).

This chipset is an ideal means to solve EMI and cable size problems associated with wide, high-speed TTL interfaces.

### Block Diagram

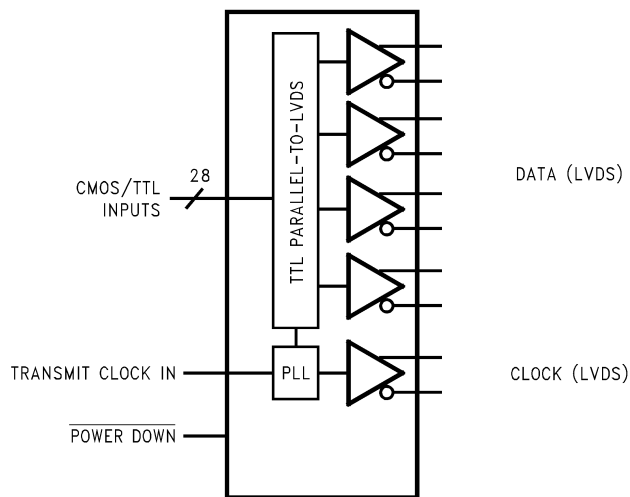

**Figure 1. DS90CR287**  
See Package Number DGG-56 (TSSOP)

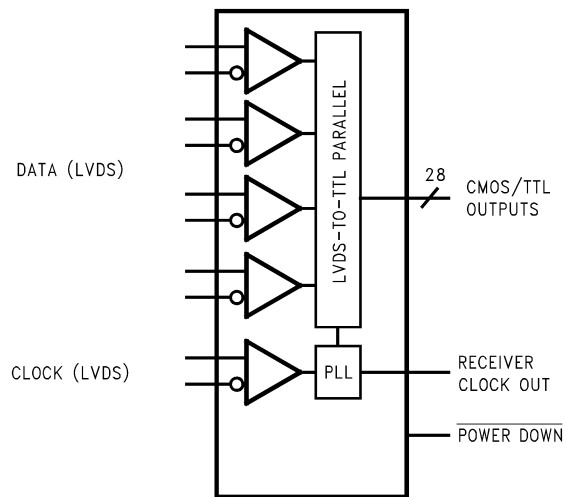

**Figure 2. DS90CR288A**  
See Package Number DGG-56 (TSSOP)



Please be aware that an important notice concerning availability, standard warranty, and use in critical applications of Texas Instruments semiconductor products and disclaimers thereto appears at the end of this data sheet.

Pin Diagram for TSSOP Packages

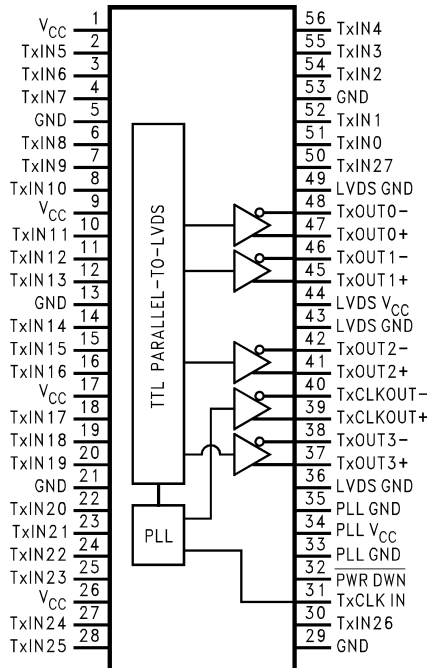

Figure 3. DS90CR287

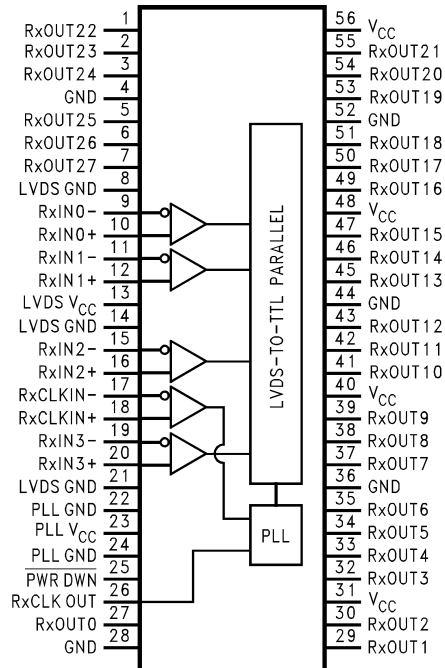

Figure 4. DS90CR288A

Typical Application

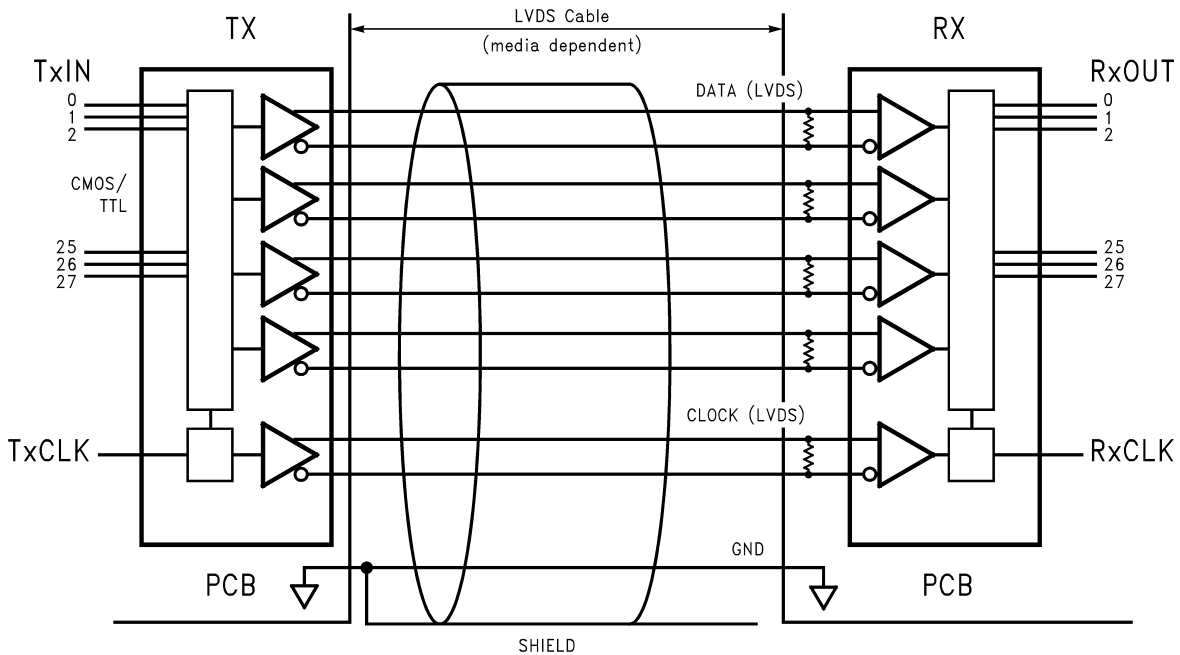

Figure 5. DS90CR288A



These devices have limited built-in ESD protection. The leads should be shorted together or the device placed in conductive foam during storage or handling to prevent electrostatic damage to the MOS gates.

**Absolute Maximum Ratings<sup>(1)(2)</sup>**

Supply Voltage ( $V_{CC}$ )			-0.3V to +4V
CMOS/TTL Input Voltage			-0.5V to ( $V_{CC} + 0.3V$ )
CMOS/TTL Output Voltage			-0.3V to ( $V_{CC} + 0.3V$ )
LVDS Receiver Input Voltage			-0.3V to ( $V_{CC} + 0.3V$ )
LVDS Driver Output Voltage			-0.3V to ( $V_{CC} + 0.3V$ )
LVDS Output Short Circuit Duration			Continuous
Junction Temperature			+150°C
Storage Temperature			-65°C to +150°C
Lead Temperature (Soldering, 4 sec.)			+260°C
Solder Reflow Temperature			
Maximum Package Power Dissipation @ +25°C	TSSOP Package	DS90CR287	1.63 W
		DS90CR288A	1.61 W
Package Derating	DS90CR287		12.5 mW/°C above +25°C
	DS90CR288A		12.4 mW/°C above +25°C
ESD Rating	(HBM, 1.5kΩ, 100pF)		> 7kV
	(EIAJ, 0Ω, 200pF)		> 700V
	Latch Up Tolerance @ +25°C		> ±300mA

- (1) "Absolute Maximum Ratings" are those values beyond which the safety of the device cannot be guaranteed. They are not meant to imply that the device should be operated at these limits. "Electrical Characteristics" specify conditions for device operation.
- (2) If Military/Aerospace specified devices are required, please contact the Texas Instruments Sales Office/ Distributors for availability and specifications.

**Recommended Operating Conditions**

	Min	Nom	Max	Units
Supply Voltage ( $V_{CC}$ )	3.0	3.3	3.6	V
Operating Free Air Temperature ( $T_A$ )	-10	+25	+70	°C
Receiver Input Range	0		2.4	V
Supply Noise Voltage ( $V_{CC}$ )			100	mV <sub>PP</sub>

## Electrical Characteristics<sup>(1)</sup>

Over recommended operating supply and temperature ranges unless otherwise specified

Symbol	Parameter	Conditions	Min	Typ <sup>(2)</sup>	Max	Units	
<b>LVCMOS/LVTTL DC SPECIFICATIONS</b>							
V <sub>IH</sub>	High Level Input Voltage		2.0		V <sub>CC</sub>	V	
V <sub>IL</sub>	Low Level Input Voltage		GND		0.8	V	
V <sub>OH</sub>	High Level Output Voltage	I <sub>OH</sub> = -0.4 mA	2.7	3.3		V	
V <sub>OL</sub>	Low Level Output Voltage	I <sub>OL</sub> = 2 mA		0.06	0.3	V	
V <sub>CL</sub>	Input Clamp Voltage	I <sub>CL</sub> = -18 mA		-0.79	-1.5	V	
I <sub>IN</sub>	Input Current	V <sub>IN</sub> = 0.4V, 2.5V or V <sub>CC</sub>		+1.8	+15	μA	
		V <sub>IN</sub> = GND	-10	0		μA	
I <sub>OS</sub>	Output Short Circuit Current	V <sub>OUT</sub> = 0V		-60	-120	mA	
<b>LVDS DRIVER DC SPECIFICATIONS</b>							
V <sub>OD</sub>	Differential Output Voltage	R <sub>L</sub> = 100Ω	250	290	450	mV	
ΔV <sub>OD</sub>	Change in V <sub>OD</sub> between Complimentary Output States				35	mV	
V <sub>OS</sub>	Offset Voltage <sup>(3)</sup>		1.125	1.25	1.375	V	
ΔV <sub>OS</sub>	Change in V <sub>OS</sub> between Complimentary Output States				35	mV	
I <sub>OS</sub>	Output Short Circuit Current	V <sub>OUT</sub> = 0V, R <sub>L</sub> = 100Ω		-3.5	-5	mA	
I <sub>OZ</sub>	Output TRI-STATE Current	PWR DWN = 0V, V <sub>OUT</sub> = 0V or V <sub>CC</sub>		±1	±10	μA	
<b>LVDS RECEIVER DC SPECIFICATIONS</b>							
V <sub>TH</sub>	Differential Input High Threshold	V <sub>CM</sub> = +1.2V			+100	mV	
V <sub>TL</sub>	Differential Input Low Threshold		-100			mV	
I <sub>IN</sub>	Input Current	V <sub>IN</sub> = +2.4V, V <sub>CC</sub> = 3.6V			±10	μA	
		V <sub>IN</sub> = 0V, V <sub>CC</sub> = 3.6V			±10	μA	
<b>TRANSMITTER SUPPLY CURRENT</b>							
I <sub>CC</sub> TW	Transmitter Supply Current Worst Case (with Loads) <sup>(4)</sup>	R <sub>L</sub> = 100Ω, C <sub>L</sub> = 5 pF, Worst Case Pattern <a href="#">Figure 6</a> , <a href="#">Figure 7</a>	f = 33 MHz		31	45	mA
			f = 40 MHz		32	50	mA
			f = 66 MHz		37	55	mA
			f = 85 MHz		42	60	mA
I <sub>CC</sub> TZ	Transmitter Supply Current Power Down <sup>(4)</sup>	PWR DWN = Low Driver Outputs in TRI-STATE under Powerdown Mode			10	55	μA
<b>RECEIVER SUPPLY CURRENT</b>							
I <sub>CC</sub> RW	Receiver Supply Current Worst Case	C <sub>L</sub> = 8 pF, Worst Case Pattern <a href="#">Figure 6</a> , <a href="#">Figure 8</a>	f = 33 MHz		49	70	mA
			f = 40 MHz		53	75	mA
			f = 66 MHz		81	114	mA
			f = 85 MHz		96	135	mA
I <sub>CC</sub> RZ	Receiver Supply Current Power Down	PWR DWN = Low Receiver Outputs Stay Low during Powerdown Mode			140	400	μA

(1) "Absolute Maximum Ratings" are those values beyond which the safety of the device cannot be guaranteed. They are not meant to imply that the device should be operated at these limits. "Electrical Characteristics" specify conditions for device operation.

(2) Typical values are given for V<sub>CC</sub> = 3.3V and T<sub>A</sub> = +25°C.

(3) V<sub>OS</sub> previously referred as V<sub>CM</sub>.

(4) Current into device pins is defined as positive. Current out of device pins is defined as negative. Voltages are referenced to ground unless otherwise specified (except V<sub>OD</sub> and ΔV<sub>OD</sub>).

## Transmitter Switching Characteristics

Over recommended operating supply and temperature ranges unless otherwise specified

Symbol	Parameter	Min	Typ <sup>(1)</sup>	Max	Units		
LLHT	LVDS Low-to-High Transition Time <a href="#">Figure 7</a>		0.75	1.5	ns		
LHLT	LVDS High-to-Low Transition Time <a href="#">Figure 7</a>		0.75	1.5	ns		
TCIT	TxCLK IN Transition Time <a href="#">Figure 9</a>	1.0		6.0	ns		
TPPos0	Transmitter Output Pulse Position for Bit0 <a href="#">Figure 19</a>	f = 85 MHz		-0.20	0	0.20	ns
TPPos1	Transmitter Output Pulse Position for Bit1		1.48	1.68	1.88	ns	
TPPos2	Transmitter Output Pulse Position for Bit2		3.16	3.36	3.56	ns	
TPPos3	Transmitter Output Pulse Position for Bit3		4.84	5.04	5.24	ns	
TPPos4	Transmitter Output Pulse Position for Bit4		6.52	6.72	6.92	ns	
TPPos5	Transmitter Output Pulse Position for Bit5		8.20	8.40	8.60	ns	
TPPos6	Transmitter Output Pulse Position for Bit6		9.88	10.08	10.28	ns	
TCIP	TxCLK IN Period <a href="#">Figure 10</a>	11.76	T	50	ns		
TCIH	TxCLK IN High Time <a href="#">Figure 10</a>	0.35T	0.5T	0.65T	ns		
TCIL	TxCLK IN Low Time <a href="#">Figure 10</a>	0.35T	0.5T	0.65T	ns		
TSTC	TxIN Setup to TxCLK IN <a href="#">Figure 10</a>	f = 85 MHz		2.5		ns	
THTC	TxIN Hold to TxCLK IN <a href="#">Figure 10</a>			0		ns	
TCCD	TxCLK IN to TxCLK OUT Delay <a href="#">Figure 12</a>	T <sub>A</sub> = 25°C, V <sub>CC</sub> = 3.3V		3.8		6.3	ns
TPLLS	Transmitter Phase Lock Loop Set <a href="#">Figure 14</a>			10		ms	
TPDD	Transmitter Powerdown Delay <a href="#">Figure 17</a>			100		ns	
TJIT	TxCLK IN Cycle-to-Cycle Jitter (Input clock requirement)			2		ns	

(1) Typical values are given for V<sub>CC</sub> = 3.3V and T<sub>A</sub> = +25°C.

## Receiver Switching Characteristics

Over recommended operating supply and temperature ranges unless otherwise specified

Symbol	Parameter	Min	Typ <sup>(1)</sup>	Max	Units	
CLHT	CMOS/TTL Low-to-High Transition Time <a href="#">Figure 8</a>		2	3.5	ns	
CHLT	CMOS/TTL High-to-Low Transition Time <a href="#">Figure 8</a>		1.8	3.5	ns	
RSPos0	Receiver Input Strobe Position for Bit 0 <a href="#">Figure 20</a>	f = 85 MHz	0.49	0.84	1.19	ns
RSPos1	Receiver Input Strobe Position for Bit 1		2.17	2.52	2.87	ns
RSPos2	Receiver Input Strobe Position for Bit 2		3.85	4.20	4.55	ns
RSPos3	Receiver Input Strobe Position for Bit 3		5.53	5.88	6.23	ns
RSPos4	Receiver Input Strobe Position for Bit 4		7.21	7.56	7.91	ns
RSPos5	Receiver Input Strobe Position for Bit 5		8.89	9.24	9.59	ns
RSPos6	Receiver Input Strobe Position for Bit 6		10.57	10.92	11.27	ns
RSKM	RxIN Skew Margin <sup>(2)</sup> <a href="#">Figure 21</a>	f = 85 MHz	290		ps	
RCOP	RxCLK OUT Period <a href="#">Figure 11</a>		11.76	T	50	ns
RCOH	RxCLK OUT High Time <a href="#">Figure 11</a>	f = 85 MHz	4	5	6.5	ns
RCOL	RxCLK OUT Low Time <a href="#">Figure 11</a>		3.5	5	6	ns
RSRC	RxOUT Setup to RxCLK OUT <a href="#">Figure 11</a>		3.5			ns
RHRC	RxOUT Hold to RxCLK OUT <a href="#">Figure 11</a>		3.5			ns
RCCD	RxCLK IN to RxCLK OUT Delay @ 25°C, V <sub>CC</sub> = 3.3V <sup>(3)</sup> <a href="#">Figure 13</a>		5.5	7	9.5	ns
RPLLS	Receiver Phase Lock Loop Set <a href="#">Figure 15</a>				10	ms
RPDD	Receiver Powerdown Delay <a href="#">Figure 18</a>				1	μs

(1) Typical values are given for V<sub>CC</sub> = 3.3V and T<sub>A</sub> = +25°C.

(2) Receiver Skew Margin is defined as the valid data sampling region at the receiver inputs. This margin takes into account the transmitter pulse positions (min and max) and the receiver input setup and hold time (internal data sampling window-RSPOS). This margin allows LVDS interconnect skew, inter-symbol interference (both dependent on type/length of cable), and source clock (less than 150 ps).

(3) Total latency for the channel link chipset is a function of clock period and gate delays through the transmitter (TCCD) and receiver (RCCD). The total latency for the 217/287 transmitter and 218/288A receiver is: (T + TCCD) + (2\*T + RCCD), where T = Clock period.

AC Timing Diagrams

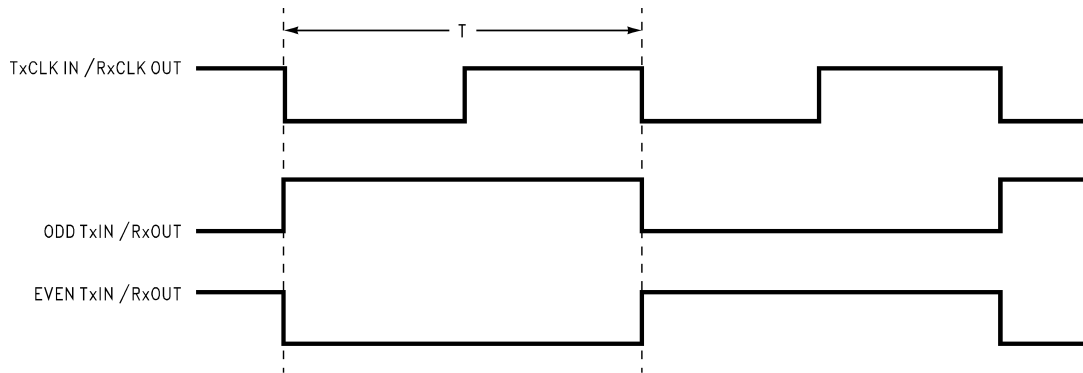

Figure 6. "Worst Case" Test Pattern

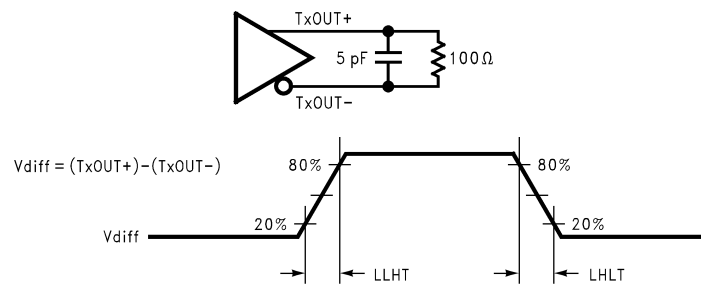

Figure 7. DS90CR287 (Transmitter) LVDS Output Load and Transition Times

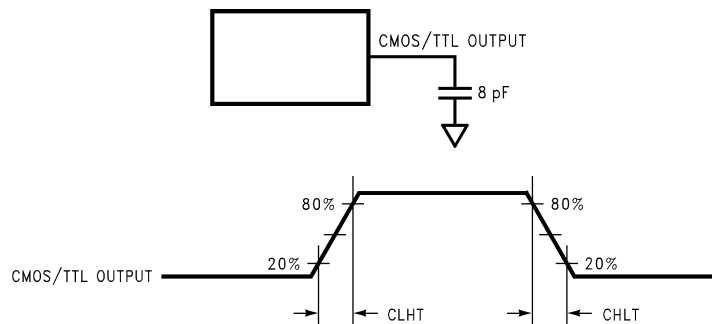

Figure 8. DS90CR288A (Receiver) CMOS/TTL Output Load and Transition Times

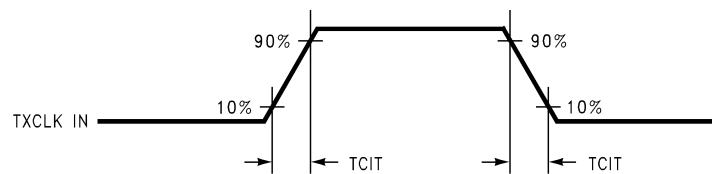

Figure 9. DS90CR287 (Transmitter) Input Clock Transition Time

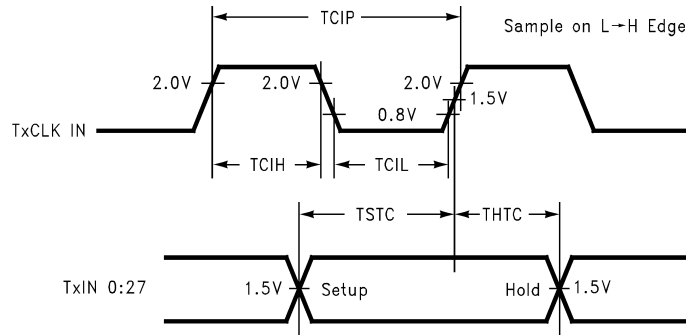

Figure 10. DS90CR287 (Transmitter) Setup/Hold and High/Low Times

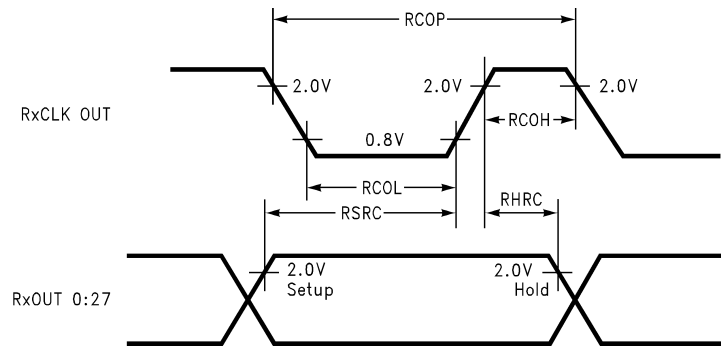

Figure 11. DS90CR288A (Receiver) Setup/Hold and High/Low Times

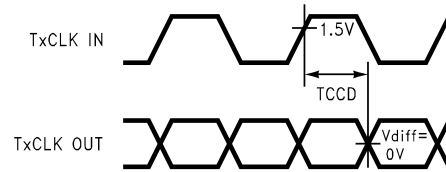

Figure 12. DS90CR287 (Transmitter) Clock In to Clock Out Delay

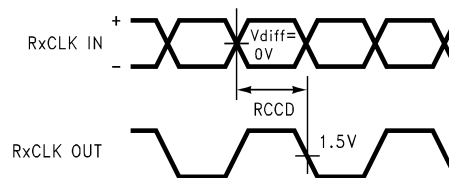

Figure 13. DS90CR288A (Receiver) Clock In to Clock Out Delay

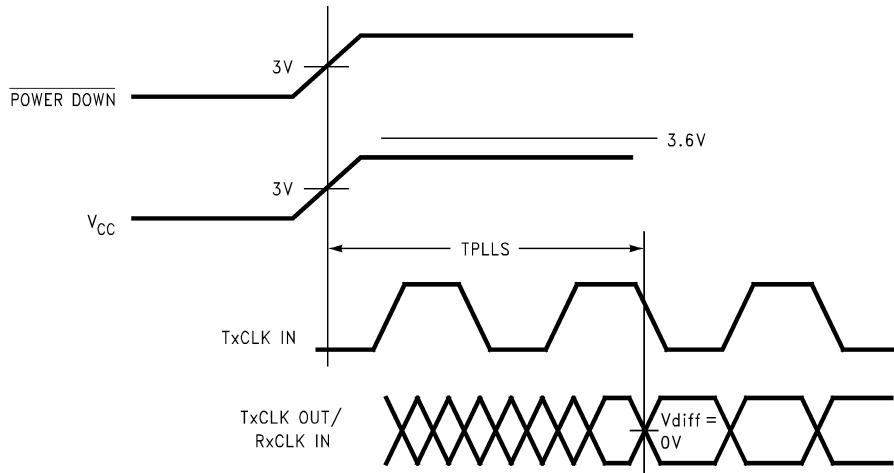

Figure 14. DS90CR287 (Transmitter) Phase Lock Loop Set Time

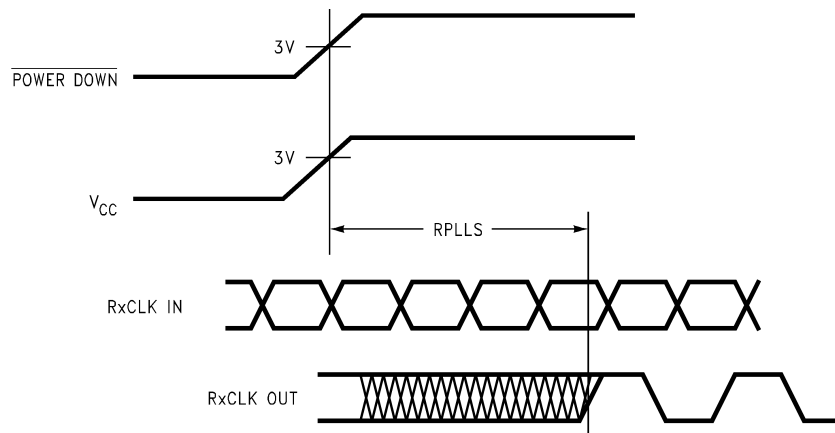

Figure 15. DS90CR288A (Receiver) Phase Lock Loop Set Time

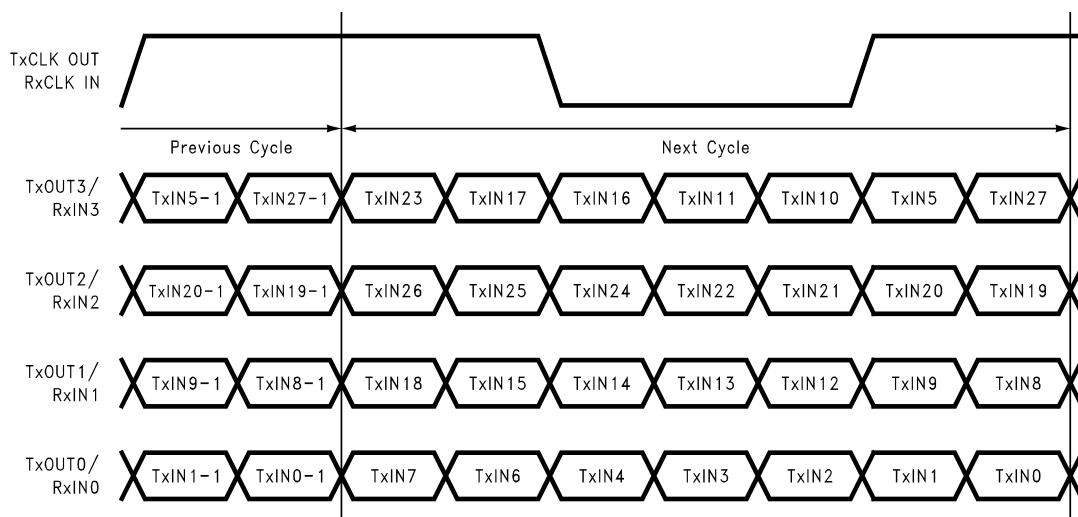

Figure 16. 28 Parallel TTL Data Inputs Mapped to LVDS Outputs

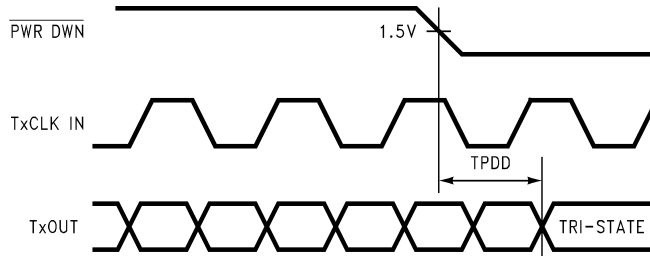

Figure 17. Transmitter Powerdown Delay

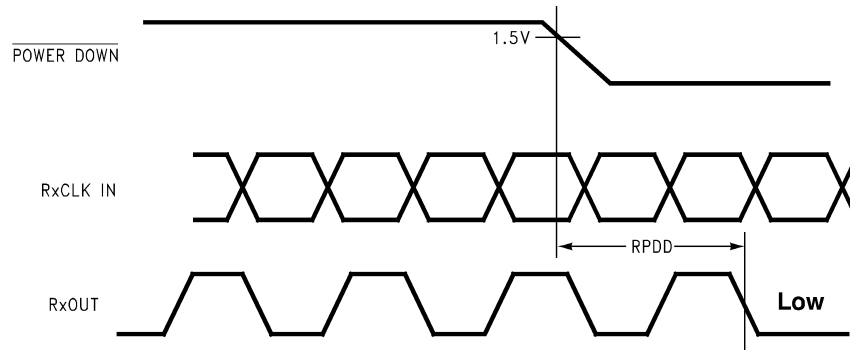

Figure 18. Receiver Powerdown Delay

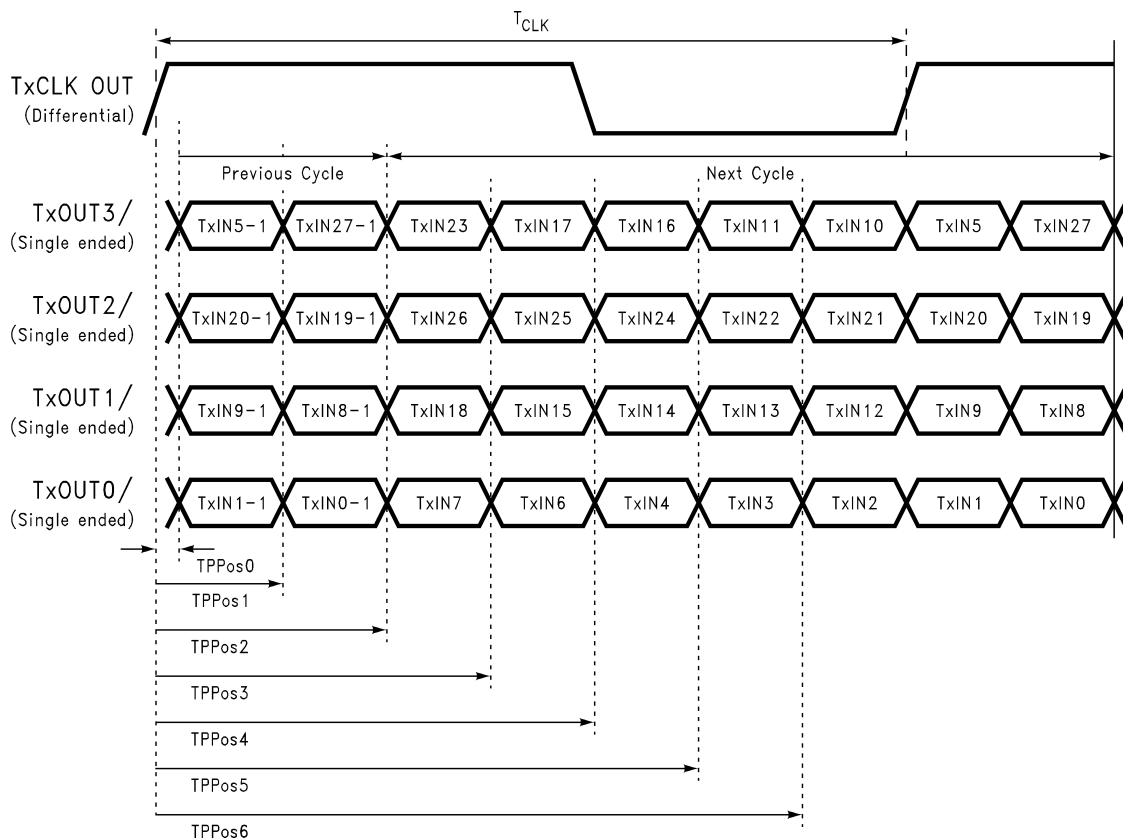

Figure 19. Transmitter LVDS Output Pulse Position Measurement

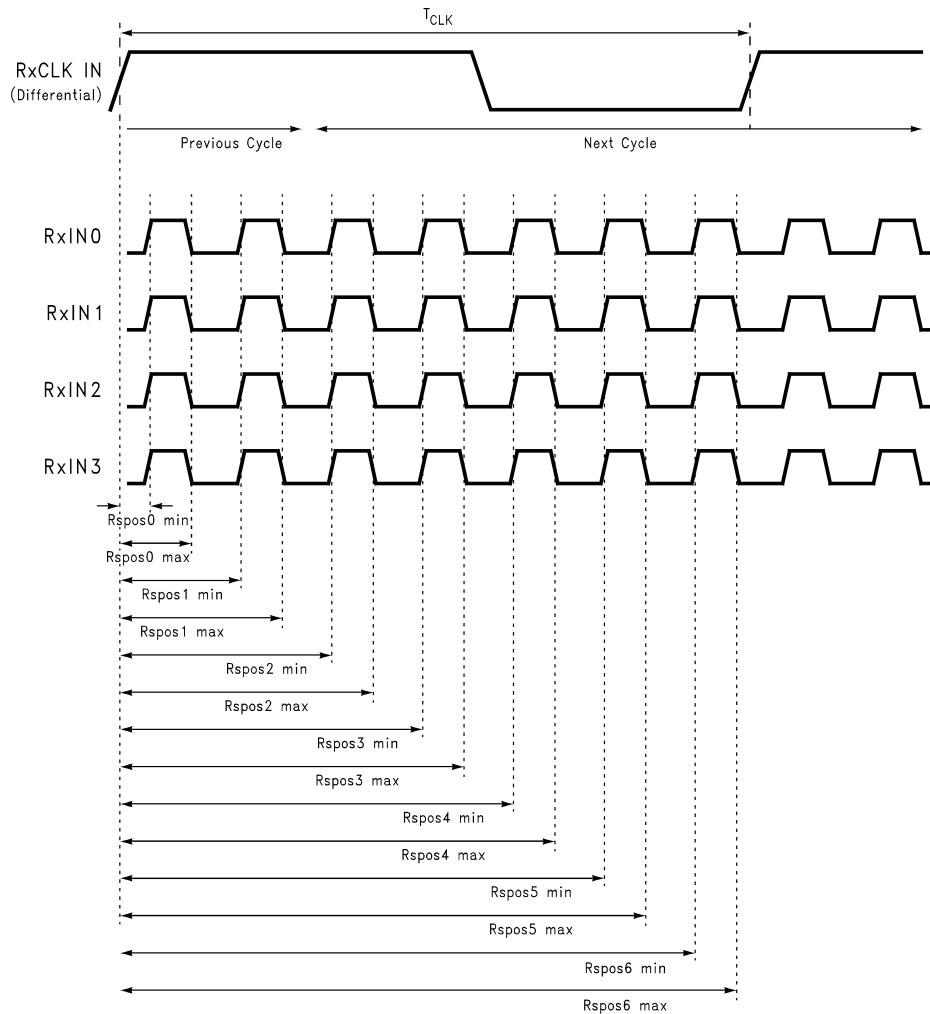
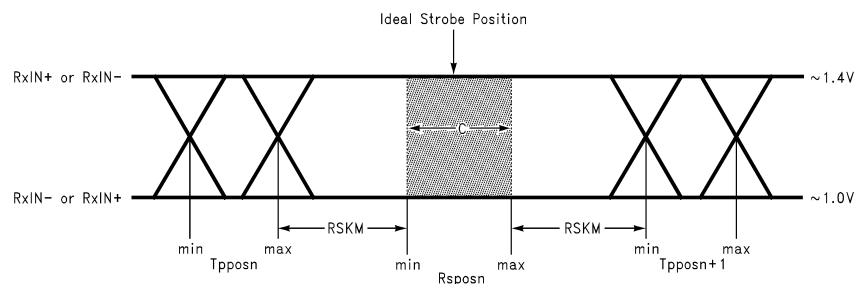

Figure 20. Receiver LVDS Input Strobe Position



C—Setup and Hold Time (Internal data sampling window) defined by Rspos (receiver input strobe position) min and max

Tppos—Transmitter output pulse position (min and max)

$RSKM \geq \text{Cable Skew (type, length)} + \text{Source Clock Jitter (cycle to cycle)}^{(1)} + \text{ISI (Inter-symbol interference)}^{(2)}$

Cable Skew—typically 10 ps–40 ps per foot, media dependent

- (1) Cycle-to-cycle jitter is less than 150ps at 85MHz.
- (2) ISI is dependent on interconnect length; may be zero.

Figure 21. Receiver LVDS Input Skew Margin

**DS90CR287 DGG (TSSOP) Package PIN DESCRIPTION — Channel Link Transmitter**

Pin Name	I/O	No.	Description
TxIN	I	28	TTL level input.
TxOUT+	O	4	Positive LVDS differential data output.
TxOUT-	O	4	Negative LVDS differential data output.
TxCLK IN	I	1	TTL level clock input. The rising edge acts as data strobe. Pin name TxCLK IN. See <a href="#">APPLICATIONS INFORMATION</a> section.
TxCLK OUT+	O	1	Positive LVDS differential clock output.
TxCLK OUT-	O	1	Negative LVDS differential clock output.
$\overline{\text{PWR DOWN}}$	I	1	TTL level input. Assertion (low input) TRI-STATES the outputs, ensuring low current at power down. See <a href="#">APPLICATIONS INFORMATION</a> section.
V <sub>CC</sub>	I	4	Power supply pins for TTL inputs.
GND	I	5	Ground pins for TTL inputs.
PLL V <sub>CC</sub>	I	1	Power supply pin for PLL.
PLL GND	I	2	Ground pins for PLL.
LVDS V <sub>CC</sub>	I	1	Power supply pin for LVDS outputs.
LVDS GND	I	3	Ground pins for LVDS outputs.

**DS90CR288A DGG (TSSOP) Package PIN DESCRIPTION — Channel Link Receiver**

Pin Name	I/O	No.	Description
RxIN+	I	4	Positive LVDS differential data inputs.
RxIN-	I	4	Negative LVDS differential data inputs.
RxOUT	O	28	TTL level data outputs.
RxCLK IN+	I	1	Positive LVDS differential clock input.
RxCLK IN-	I	1	Negative LVDS differential clock input.
RxCLK OUT	O	1	TTL level clock output. The rising edge acts as data strobe. Pin name RxCLK OUT.
$\overline{\text{PWR DOWN}}$	I	1	TTL level input. When asserted (low input) the receiver outputs are low.
V <sub>CC</sub>	I	4	Power supply pins for TTL outputs.
GND	I	5	Ground pins for TTL outputs.
PLL V <sub>CC</sub>	I	1	Power supply for PLL.
PLL GND	I	2	Ground pin for PLL.
LVDS V <sub>CC</sub>	I	1	Power supply pin for LVDS inputs.
LVDS GND	I	3	Ground pins for LVDS inputs.

## APPLICATIONS INFORMATION

The TSSOP version of the DS90CR287 and DS90CR288A are backward compatible with the existing 5V Channel Link transmitter/receiver pair (DS90CR283, DS90CR284). To upgrade from a 5V to a 3.3V system the following must be addressed:

1. Change 5V power supply to 3.3V. Provide this supply to the  $V_{CC}$ , LVDS  $V_{CC}$  and PLL  $V_{CC}$ .
2. Transmitter input and control inputs except 3.3V TTL/CMOS levels. They are not 5V tolerant.
3. The receiver powerdown feature when enabled will lock receiver output to a logic low.

The Channel Link devices are intended to be used in a wide variety of data transmission applications. Depending upon the application the interconnecting media may vary. For example, for lower data rate (clock rate) and shorter cable lengths (< 2m), the media electrical performance is less critical. For higher speed/long distance applications the media's performance becomes more critical. Certain cable constructions provide tighter skew (matched electrical length between the conductors and pairs). Additional applications information can be found in the following Interface Application Notes:

AN = ####	Topic
AN-1041 ( <a href="#">SNLA218</a> )	Introduction to Channel Link
AN-1108( <a href="#">SNLA008</a> )	Channel Link PCB and Interconnect Design-In Guidelines
AN-806 ( <a href="#">SNLA026</a> )	Transmission Line Theory
AN-905 ( <a href="#">SNLA035</a> )	Transmission Line Calculations and Differential Impedance
AN-916 ( <a href="#">SNLA219</a> )	Cable Information

**CABLES:** A cable interface between the transmitter and receiver needs to support the differential LVDS pairs. The 21-bit CHANNEL LINK chipset (DS90CR217/218A) requires four pairs of signal wires and the 28-bit CHANNEL LINK chipset (DS90CR287/288A) requires five pairs of signal wires. The ideal cable/connector interface would have a constant 100Ω differential impedance throughout the path. It is also recommended that cable skew remain below 140ps (@ 85 MHz clock rate) to maintain a sufficient data sampling window at the receiver.

In addition to the four or five cable pairs that carry data and clock, it is recommended to provide at least one additional conductor (or pair) which connects ground between the transmitter and receiver. This low impedance ground provides a common-mode return path for the two devices. Some of the more commonly used cable types for point-to-point applications include flat ribbon, flex, twisted pair and Twin-Coax. All are available in a variety of configurations and options. Flat ribbon cable, flex and twisted pair generally perform well in short point-to-point applications while Twin-Coax is good for short and long applications. When using ribbon cable, it is recommended to place a ground line between each differential pair to act as a barrier to noise coupling between adjacent pairs. For Twin-Coax cable applications, it is recommended to utilize a shield on each cable pair. All extended point-to-point applications should also employ an overall shield surrounding all cable pairs regardless of the cable type. This overall shield results in improved transmission parameters such as faster attainable speeds, longer distances between transmitter and receiver and reduced problems associated with EMS or EMI.

The high-speed transport of LVDS signals has been demonstrated on several types of cables with excellent results. However, the best overall performance has been seen when using Twin-Coax cable. Twin-Coax has very low cable skew and EMI due to its construction and double shielding. All of the design considerations discussed here and listed in the supplemental application notes provide the subsystem communications designer with many useful guidelines. It is recommended that the designer assess the tradeoffs of each application thoroughly to arrive at a reliable and economical cable solution.

**RECEIVER FAILSAFE FEATURE:** These receivers have input failsafe bias circuitry to guarantee a stable receiver output for floating or terminated receiver inputs. Under these conditions receiver inputs will be in a HIGH state. If a clock signal is present, data outputs will all be HIGH; if the clock input is also floating/terminated, data outputs will remain in the last valid state. A floating/terminated clock input will result in a HIGH clock output.

**BOARD LAYOUT:** To obtain the maximum benefit from the noise and EMI reductions of LVDS, attention should be paid to the layout of differential lines. Lines of a differential pair should always be adjacent to eliminate noise interference from other signals and take full advantage of the noise canceling of the differential signals. The board designer should also try to maintain equal length on signal traces for a given differential pair. As with any high-speed design, the impedance discontinuities should be limited (reduce the numbers of vias and no 90 degree angles on traces). Any discontinuities which do occur on one signal line should be mirrored in the other

line of the differential pair. Care should be taken to ensure that the differential trace impedance match the differential impedance of the selected physical media (this impedance should also match the value of the termination resistor that is connected across the differential pair at the receiver's input). Finally, the location of the CHANNEL LINK TxOUT/RxIN pins should be as close as possible to the board edge so as to eliminate excessive pcb runs. All of these considerations will limit reflections and crosstalk which adversely effect high frequency performance and EMI.

**INPUTS:** The TxIN and control pin inputs are compatible with LVTTTL and LVCMOS levels. This pins are not 5V tolerant.

**UNUSED INPUTS:** All unused inputs at the TxIN inputs of the transmitter may be tied to ground or left no connect. All unused outputs at the RxOUT outputs of the receiver must then be left floating.

**TERMINATION:** Use of current mode drivers requires a terminating resistor across the receiver inputs. The CHANNEL LINK chipset will normally require a single 100Ω resistor between the true and complement lines on each differential pair of the receiver input. The actual value of the termination resistor should be selected to match the differential mode characteristic impedance (90Ω to 120Ω typical) of the cable. Figure 22 shows an example. No additional pull-up or pull-down resistors are necessary as with some other differential technologies such as PECL. Surface mount resistors are recommended to avoid the additional inductance that accompanies leaded resistors. These resistors should be placed as close as possible to the receiver input pins to reduce stubs and effectively terminate the differential lines.

**DECOUPLING CAPACITORS:** Bypassing capacitors are needed to reduce the impact of switching noise which could limit performance. For a conservative approach three parallel-connected decoupling capacitors (Multi-Layered Ceramic type in surface mount form factor) between each  $V_{CC}$  and the ground plane(s) are recommended. The three capacitor values are 0.1 μF, 0.01 μF and 0.001 μF. An example is shown in Figure 23. The designer should employ wide traces for power and ground and ensure each capacitor has its own via to the ground plane. If board space is limiting the number of bypass capacitors, the PLL  $V_{CC}$  should receive the most filtering/bypassing. Next would be the LVDS  $V_{CC}$  pins and finally the logic  $V_{CC}$  pins.

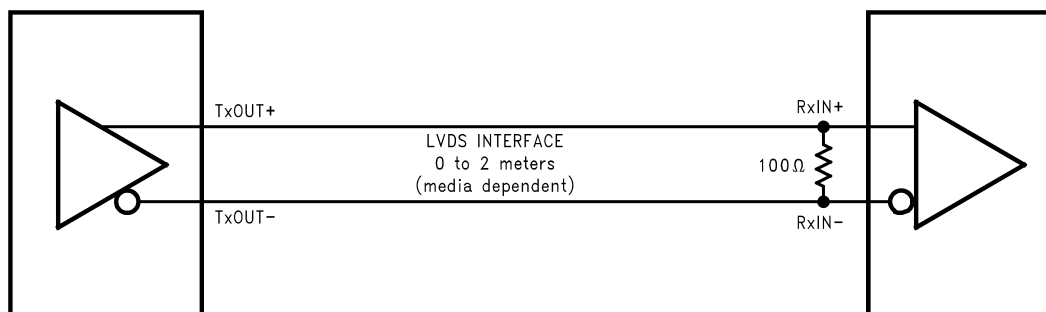

Figure 22. LVDS Serialized Link Termination

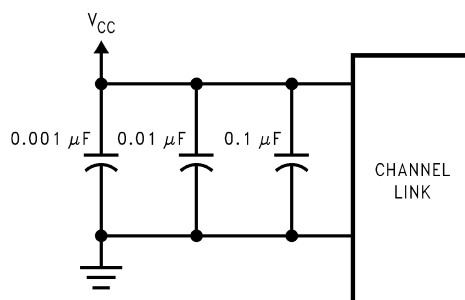

Figure 23. CHANNEL LINK Decoupling Configuration

**CLOCK JITTER:** The CHANNEL LINK devices employ a PLL to generate and recover the clock transmitted across the LVDS interface. The width of each bit in the serialized LVDS data stream is one-seventh the clock period. For example, a 85 MHz clock has a period of 11.76 ns which results in a data bit width of 1.68 ns. Differential skew ( $\Delta t$  within one differential pair), interconnect skew ( $\Delta t$  of one differential pair to another) and clock jitter will all reduce the available window for sampling the LVDS serial data streams. Care must be taken to ensure that the clock input to the transmitter be a clean low noise signal. Individual bypassing of each  $V_{CC}$  to ground will minimize the noise passed on to the PLL, thus creating a low jitter LVDS clock. These measures provide more margin for channel-to-channel skew and interconnect skew as a part of the overall jitter/skew budget.

**INPUT CLOCK:** The input clock should be present at all times when the part is enabled. If the clock is stopped, the PWR DOWN pin should be asserted to disable the PLL. Once the clock is active again, the part can then be enabled. Do not enable the part without a clock present.

**COMMON-MODE vs. DIFFERENTIAL MODE NOISE MARGIN:** The typical signal swing for LVDS is 300 mV centered at +1.2V. The CHANNEL LINK receiver supports a 100 mV threshold therefore providing approximately 200 mV of differential noise margin. Common-mode protection is of more importance to the system's operation due to the differential data transmission. LVDS supports an input voltage range of Ground to +2.4V. This allows for a  $\pm 1.0V$  shifting of the center point due to ground potential differences and common-mode noise.

**TRANSMITTER INPUT CLOCK:** The transmitter input clock must always be present when the device is enabled ( $\overline{\text{PWR DOWN}} = \text{HIGH}$ ). If the clock is stopped, the  $\overline{\text{PWR DOWN}}$  pin must be used to disable the PLL. The  $\overline{\text{PWR DOWN}}$  pin must be held low until after the input clock signal has been reapplied. This will ensure a proper device reset and PLL lock to occur.

**POWER SEQUENCING AND POWERDOWN MODE:** Outputs of the CHANNEL LINK transmitter remain in TRI-STATE until the power supply reaches 2V. Clock and data outputs will begin to toggle 10 ms after  $V_{CC}$  has reached 3V and the Powerdown pin is above 1.5V. Either device may be placed into a powerdown mode at any time by asserting the Powerdown pin (active low). Total power dissipation for each device will decrease to 5  $\mu\text{W}$  (typical).

The transmitter input clock may be applied prior to powering up and enabling the transmitter. The transmitter input clock may also be applied after power up; however, the use of the PWR DOWN pin is required. Do not power up and enable ( $\overline{\text{PWR DOWN}} = \text{HIGH}$ ) the transmitter without a valid clock signal applied to the TxCLK IN pin.

The CHANNEL LINK chipset is designed to protect itself from accidental loss of power to either the transmitter or receiver. If power to the transmit board is lost, the receiver clocks (input and output) stop. The data outputs (RxOUT) retain the states they were in when the clocks stopped. When the receiver board loses power, the receiver inputs are shorted to  $V_{CC}$  through an internal diode. Current is limited (5 mA per input) by the fixed current mode drivers, thus avoiding the potential for latchup when powering the device.

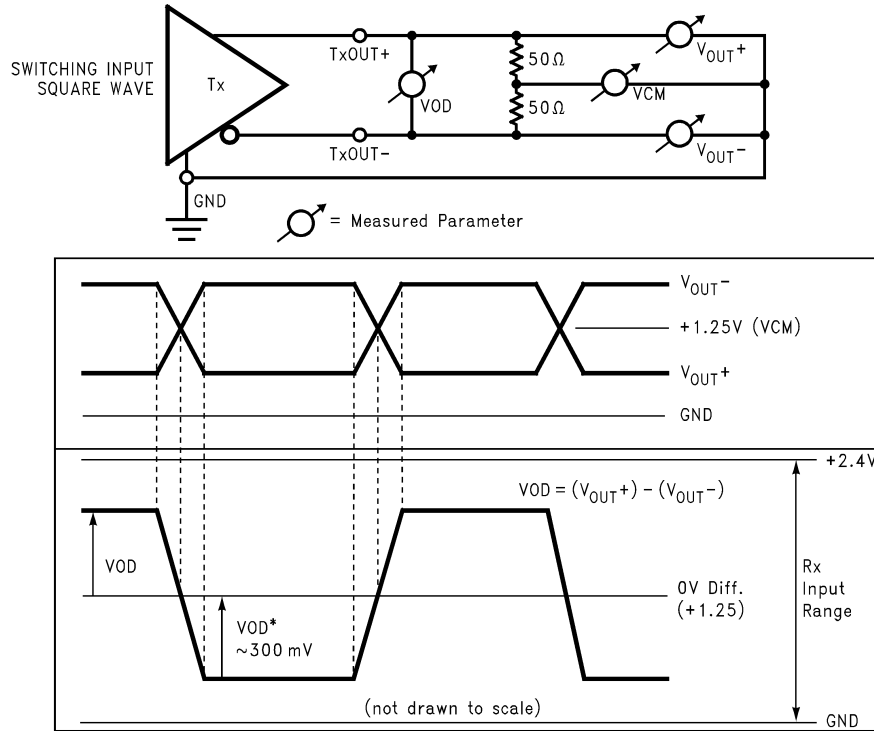

Figure 24. Single-Ended and Differential Waveforms

---

**REVISION HISTORY**

<b>Changes from Revision F (March 2013) to Revision G</b>	<b>Page</b>
<hr/> <ul style="list-style-type: none"><li>• Changed layout of National Data Sheet to TI format .....</li></ul>	<hr/> <a href="#">16</a>

**PACKAGING INFORMATION**

Orderable Device	Status (1)	Package Type	Package Drawing	Pins	Package Qty	Eco Plan (2)	Lead/Ball Finish (6)	MSL Peak Temp (3)	Op Temp (°C)	Device Marking (4/5)	Samples
DS90CR287MTD	NRND	TSSOP	DGG	56	34	TBD	Call TI	Call TI	-10 to 70	DS90CR287MTD >B	
DS90CR287MTD/NOPB	ACTIVE	TSSOP	DGG	56	34	Green (RoHS & no Sb/Br)	CU SN	Level-2-260C-1 YEAR	-10 to 70	DS90CR287MTD >B	<a href="#">Samples</a>
DS90CR287MTDX/NOPB	ACTIVE	TSSOP	DGG	56	1000	Green (RoHS & no Sb/Br)	CU SN	Level-2-260C-1 YEAR	-10 to 70	DS90CR287MTD >B	<a href="#">Samples</a>
DS90CR287SLC/NOPB	NRND	NFBGA	NZC	64	360	Green (RoHS & no Sb/Br)	SNAGCU	Level-4-260C-72 HR		DS90CR287 SLC >B	
DS90CR288AMTD	NRND	TSSOP	DGG	56	34	TBD	Call TI	Call TI	-10 to 70	DS90CR288AMTD >B	
DS90CR288AMTD/NOPB	ACTIVE	TSSOP	DGG	56	34	Green (RoHS & no Sb/Br)	CU SN	Level-2-260C-1 YEAR	-10 to 70	DS90CR288AMTD >B	<a href="#">Samples</a>
DS90CR288AMTDX/NOPB	ACTIVE	TSSOP	DGG	56	1000	Green (RoHS & no Sb/Br)	CU SN	Level-2-260C-1 YEAR	-10 to 70	DS90CR288AMTD >B	<a href="#">Samples</a>

(1) The marketing status values are defined as follows:

**ACTIVE:** Product device recommended for new designs.

**LIFEBUY:** TI has announced that the device will be discontinued, and a lifetime-buy period is in effect.

**NRND:** Not recommended for new designs. Device is in production to support existing customers, but TI does not recommend using this part in a new design.

**PREVIEW:** Device has been announced but is not in production. Samples may or may not be available.

**OBSELETE:** TI has discontinued the production of the device.

(2) **RoHS:** TI defines "RoHS" to mean semiconductor products that are compliant with the current EU RoHS requirements for all 10 RoHS substances, including the requirement that RoHS substance do not exceed 0.1% by weight in homogeneous materials. Where designed to be soldered at high temperatures, "RoHS" products are suitable for use in specified lead-free processes. TI may reference these types of products as "Pb-Free".

**RoHS Exempt:** TI defines "RoHS Exempt" to mean products that contain lead but are compliant with EU RoHS pursuant to a specific EU RoHS exemption.

**Green:** TI defines "Green" to mean the content of Chlorine (Cl) and Bromine (Br) based flame retardants meet JS709B low halogen requirements of <=1000ppm threshold. Antimony trioxide based flame retardants must also meet the <=1000ppm threshold requirement.

(3) MSL, Peak Temp. - The Moisture Sensitivity Level rating according to the JEDEC industry standard classifications, and peak solder temperature.

(4) There may be additional marking, which relates to the logo, the lot trace code information, or the environmental category on the device.

<sup>(5)</sup> Multiple Device Markings will be inside parentheses. Only one Device Marking contained in parentheses and separated by a "-" will appear on a device. If a line is indented then it is a continuation of the previous line and the two combined represent the entire Device Marking for that device.

<sup>(6)</sup> Lead/Ball Finish - Orderable Devices may have multiple material finish options. Finish options are separated by a vertical ruled line. Lead/Ball Finish values may wrap to two lines if the finish value exceeds the maximum column width.

**Important Information and Disclaimer:**The information provided on this page represents TI's knowledge and belief as of the date that it is provided. TI bases its knowledge and belief on information provided by third parties, and makes no representation or warranty as to the accuracy of such information. Efforts are underway to better integrate information from third parties. TI has taken and continues to take reasonable steps to provide representative and accurate information but may not have conducted destructive testing or chemical analysis on incoming materials and chemicals. TI and TI suppliers consider certain information to be proprietary, and thus CAS numbers and other limited information may not be available for release.

In no event shall TI's liability arising out of such information exceed the total purchase price of the TI part(s) at issue in this document sold by TI to Customer on an annual basis.

## TAPE AND REEL INFORMATION



### QUADRANT ASSIGNMENTS FOR PIN 1 ORIENTATION IN TAPE



\*All dimensions are nominal

Device	Package Type	Package Drawing	Pins	SPQ	Reel Diameter (mm)	Reel Width W1 (mm)	A0 (mm)	B0 (mm)	K0 (mm)	P1 (mm)	W (mm)	Pin1 Quadrant
DS90CR287MTDX/NOPB	TSSOP	DGG	56	1000	330.0	24.4	8.6	14.5	1.8	12.0	24.0	Q1
DS90CR288AMTDX/NOPB	TSSOP	DGG	56	1000	330.0	24.4	8.6	14.5	1.8	12.0	24.0	Q1

**TAPE AND REEL BOX DIMENSIONS**

\*All dimensions are nominal

Device	Package Type	Package Drawing	Pins	SPQ	Length (mm)	Width (mm)	Height (mm)
DS90CR287MTDX/NOPB	TSSOP	DGG	56	1000	367.0	367.0	45.0
DS90CR288AMTDX/NOPB	TSSOP	DGG	56	1000	367.0	367.0	45.0

NZC0064A

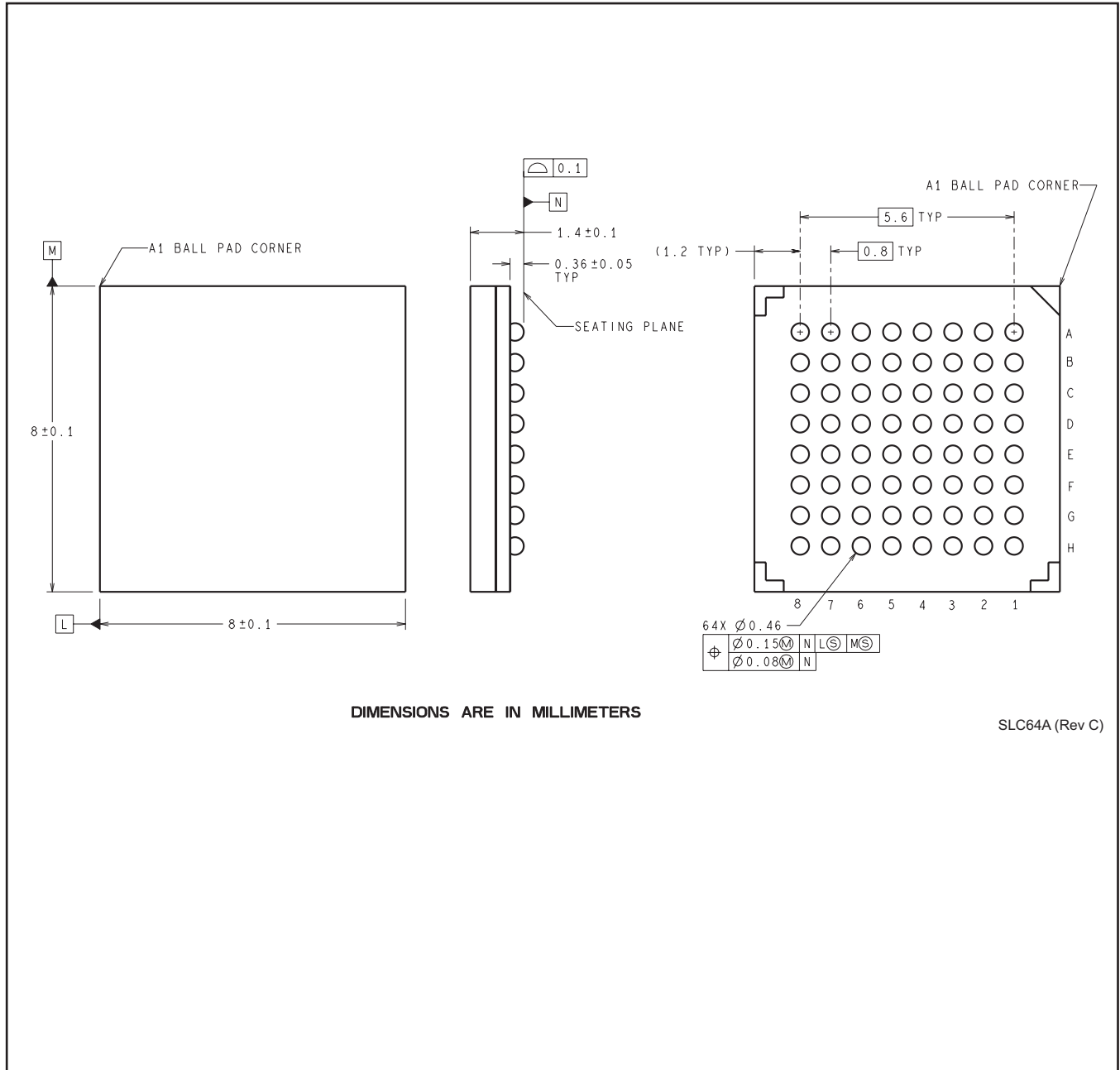

DIMENSIONS ARE IN MILLIMETERS

SLC64A (Rev C)

# DGG0056A



# PACKAGE OUTLINE

## TSSOP - 1.2 mm max height

SMALL OUTLINE PACKAGE

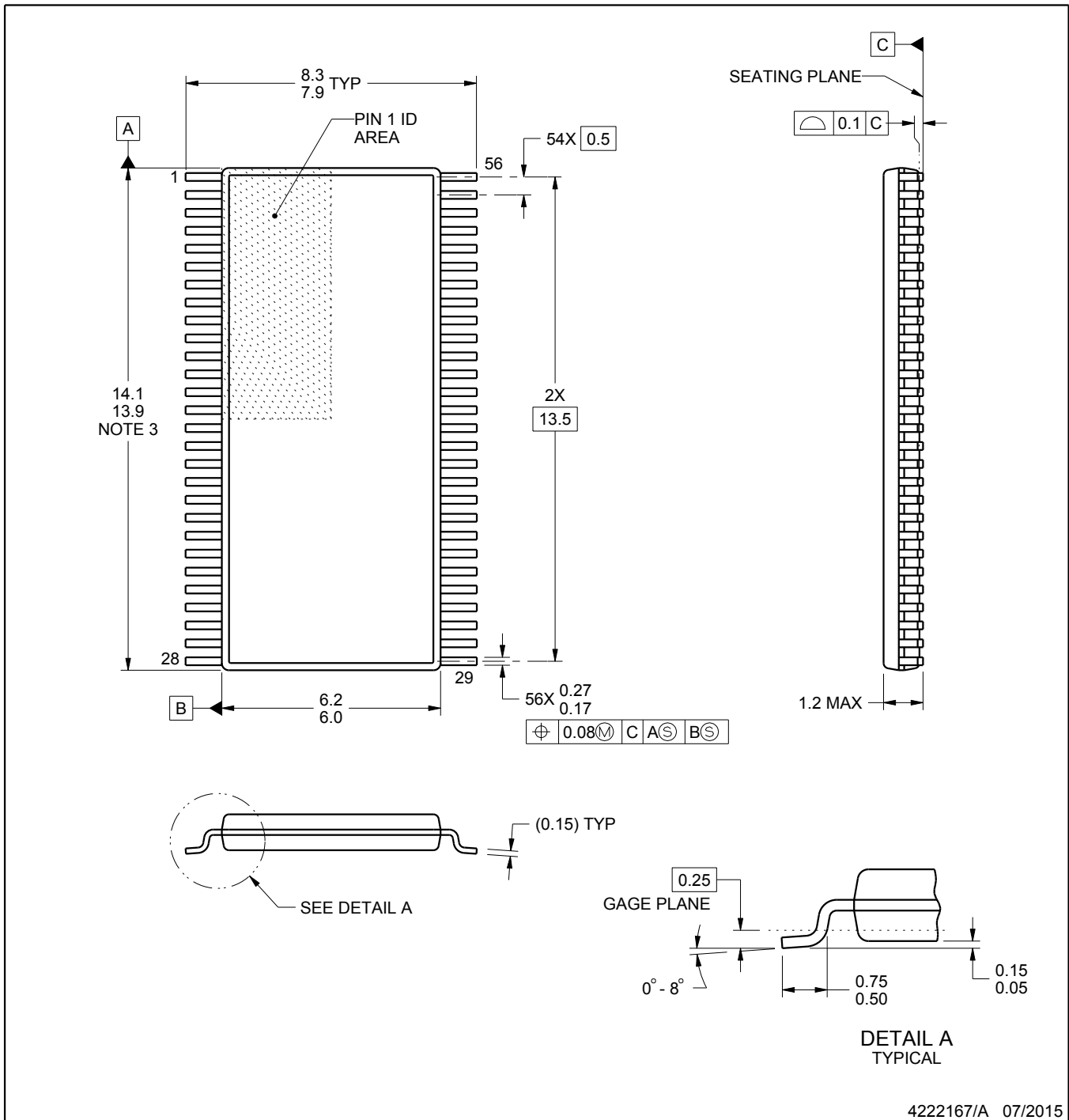

4222167/A 07/2015

### NOTES:

1. All linear dimensions are in millimeters. Any dimensions in parenthesis are for reference only. Dimensioning and tolerancing per ASME Y14.5M.
2. This drawing is subject to change without notice.
3. This dimension does not include mold flash, protrusions, or gate burrs. Mold flash, protrusions, or gate burrs shall not exceed 0.15 mm per side.
4. Reference JEDEC registration MO-153.

# EXAMPLE BOARD LAYOUT

DGG0056A

TSSOP - 1.2 mm max height

SMALL OUTLINE PACKAGE

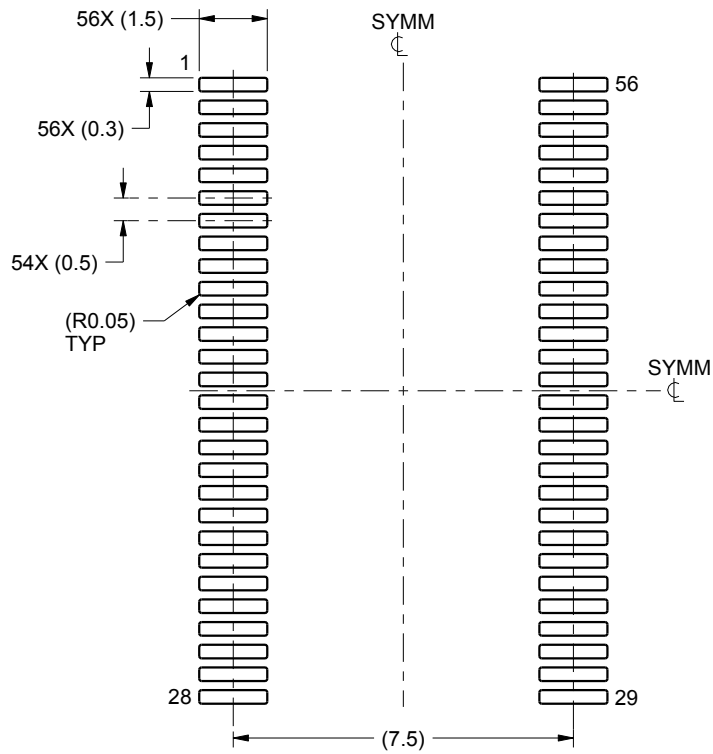

LAND PATTERN EXAMPLE  
SCALE:6X

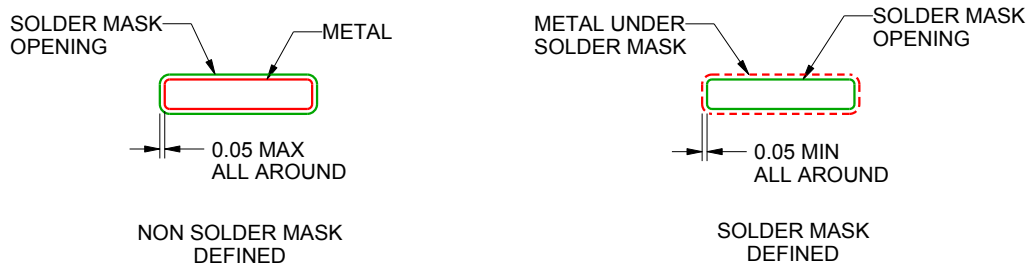

SOLDER MASK DETAILS

4222167/A 07/2015

NOTES: (continued)

- 5. Publication IPC-7351 may have alternate designs.
- 6. Solder mask tolerances between and around signal pads can vary based on board fabrication site.

# EXAMPLE STENCIL DESIGN

DGG0056A

TSSOP - 1.2 mm max height

SMALL OUTLINE PACKAGE

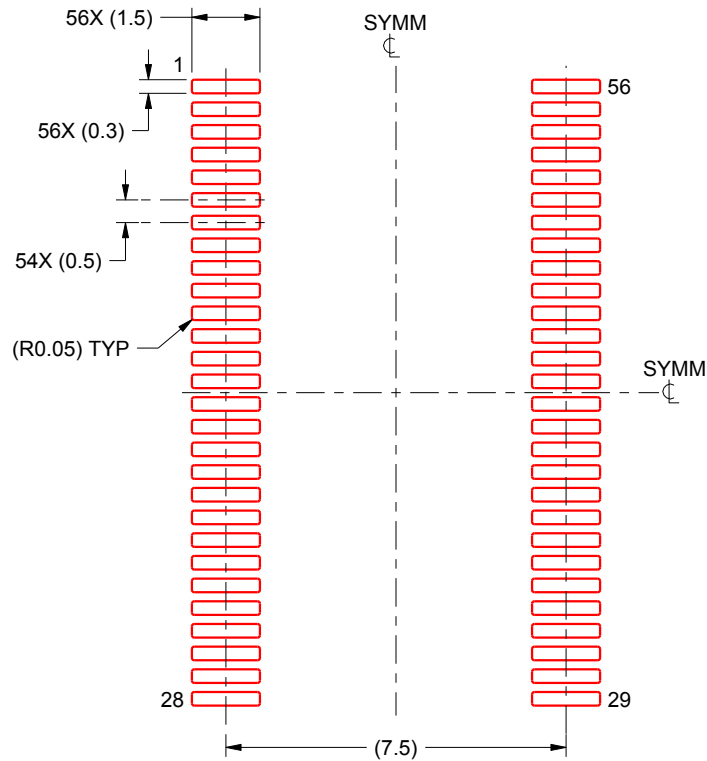

SOLDER PASTE EXAMPLE  
BASED ON 0.125 mm THICK STENCIL  
SCALE:6X

4222167/A 07/2015

NOTES: (continued)

7. Laser cutting apertures with trapezoidal walls and rounded corners may offer better paste release. IPC-7525 may have alternate design recommendations.
8. Board assembly site may have different recommendations for stencil design.

## IMPORTANT NOTICE AND DISCLAIMER

TI PROVIDES TECHNICAL AND RELIABILITY DATA (INCLUDING DATASHEETS), DESIGN RESOURCES (INCLUDING REFERENCE DESIGNS), APPLICATION OR OTHER DESIGN ADVICE, WEB TOOLS, SAFETY INFORMATION, AND OTHER RESOURCES "AS IS" AND WITH ALL FAULTS, AND DISCLAIMS ALL WARRANTIES, EXPRESS AND IMPLIED, INCLUDING WITHOUT LIMITATION ANY IMPLIED WARRANTIES OF MERCHANTABILITY, FITNESS FOR A PARTICULAR PURPOSE OR NON-INFRINGEMENT OF THIRD PARTY INTELLECTUAL PROPERTY RIGHTS.

These resources are intended for skilled developers designing with TI products. You are solely responsible for (1) selecting the appropriate TI products for your application, (2) designing, validating and testing your application, and (3) ensuring your application meets applicable standards, and any other safety, security, or other requirements. These resources are subject to change without notice. TI grants you permission to use these resources only for development of an application that uses the TI products described in the resource. Other reproduction and display of these resources is prohibited. No license is granted to any other TI intellectual property right or to any third party intellectual property right. TI disclaims responsibility for, and you will fully indemnify TI and its representatives against, any claims, damages, costs, losses, and liabilities arising out of your use of these resources.

TI's products are provided subject to TI's Terms of Sale ([www.ti.com/legal/termsofsale.html](http://www.ti.com/legal/termsofsale.html)) or other applicable terms available either on [ti.com](http://ti.com) or provided in conjunction with such TI products. TI's provision of these resources does not expand or otherwise alter TI's applicable warranties or warranty disclaimers for TI products.

Mailing Address: Texas Instruments, Post Office Box 655303, Dallas, Texas 75265  
Copyright © 2018, Texas Instruments Incorporated

## Looking for pricing, stock, or lifecycle information?

Click below to explore more details on WIN SOURCE:

 [View DS90CR287SLC](#) on WIN SOURCE

 [Texas Instruments](#) Information

## Optimize Your Supply Chain with WIN SOURCE Solutions

-  Global Sourcing Solution
-  Obsolete Management
-  Cost Control Management
-  Shortage Management
-  Alternative Solution
-  Excess Inventory Management