



**THE DATASHEET OF  
IL-AG5-C1-5000**



# IL-AG5 SERIES AUTOMOTIVE CONNECTORS

## 025 Crimp Contacts, PCB-to-Cable/Cable-to-Cable Applications

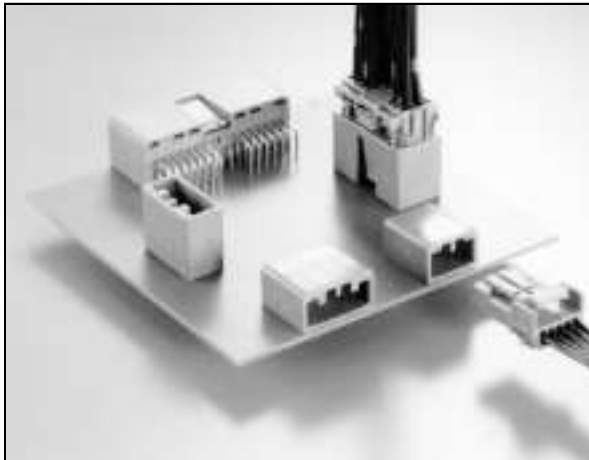

### FEATURES

- Designed for automotive instrument panel applications
- Mechanical lock assures positive mating
- Unique housing configuration helps prevent mismatching
- Double locking mechanism prevents dislodging of contacts

Connector Profile (Ref.)

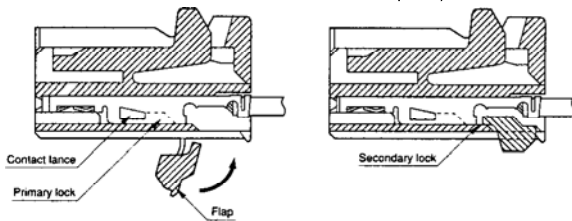

- Polarized version is available (Single row, 5 and 6 contacts only)
- Highly reliable socket contacts
- Simplified crimp-type termination

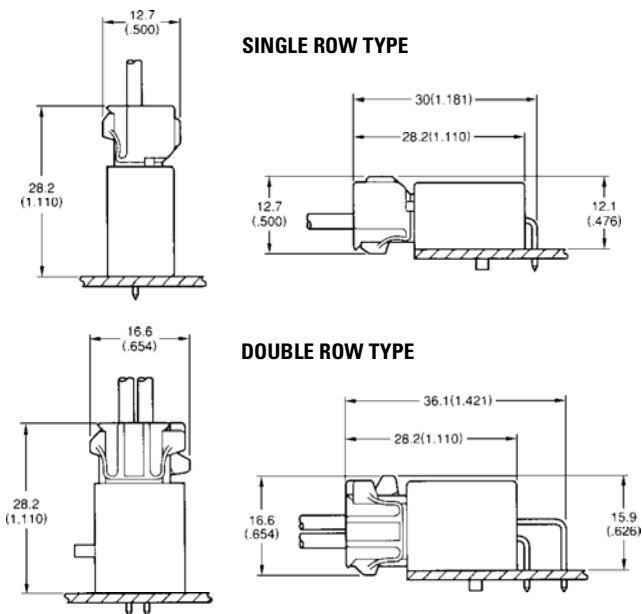

### GENERAL SPECIFICATIONS

Number of Contacts	5, 6, 7, 10 (single row) 14, 16, 18, 22, 30 (double row)
Contact Spacing	2.5mm (.098")
Current Rating	3 Amps
Dielectric Withstanding Voltage	1000 VAC r.m.s. (for one minute)
Insulation Resistance	100 megohms min.
Contact Resistance	10 milliohms max.
Applicable PCB Thickness	1.6 to 2.4mm (.063" to .094")
Operating Temperature	-40°C to +85°C

### APPLICABLE WIRE (Stranded)

Wire Type (JIS)	AV, AVS, AVSS	AVS, AVSS
AWG No.	#22 to #20	#18
Conductor Cross Section Area	0.3 to 0.5mm <sup>2</sup>	0.85mm <sup>2</sup>
Insulation Outer Dia.	1.4 to 2.4mm (.055 to .094")	

### MATERIALS AND FINISHES

Description	Materials/Finishes
Insulator	PBT, Yellow (Green or Light Blue for polarized version)
Pin Contact	Brass/Tin Plating Cable plug pin contact: Highly conductive Copper alloy
Socket Contact	Phosphor Bronze /Tin Plating

Note: The standard finish of contacts is tin plating.  
Gold plating is available as an option. Consult JAE for details.

### ORDERING INFORMATION **IL-AG5 - \*\* \* \* - \* 3 \* \* - \* - \*\***

Series	IL-AG5
No. of Contacts	5, 6, 7, 10 (Single Row) 14, 16, 18, 22, 30 (Double Row)
Contact Type	P - Pin S - Socket
Modification Code	K - Polarized version, 5 and 6 contacts only Blank - Standard type
Contact Layout	S - Single Row D - Double Row
Contact Pitch	3 - 2.5mm (.098")
Termination	T - Straight Through Hole L - Right Angle Through Hole C - Crimp
Applicable PCB Thickness (pin header)	2 - 1.6mm (.063")
Applicable Wire Size (Housing)	1 - AWG #18 to #22, Stranded
Modification Code A	
Insulator Color	LB - Light Blue Blank - Green

Dimensions and specifications subject to change without notice.

# IL-AG5 SERIES AUTOMOTIVE CONNECTORS

## 025 Crimp Contacts, PCB-to-Cable/Cable-to-Cable Applications

### STRAIGHT PIN HEADER

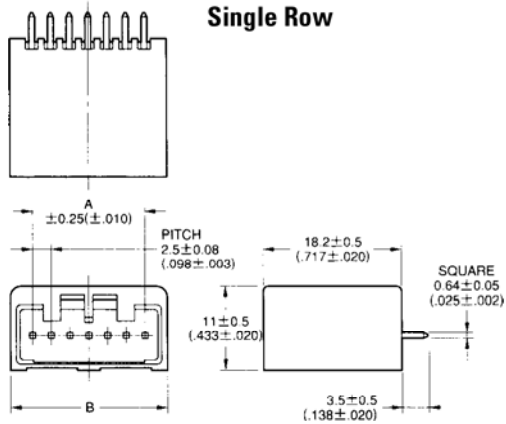

Single Row

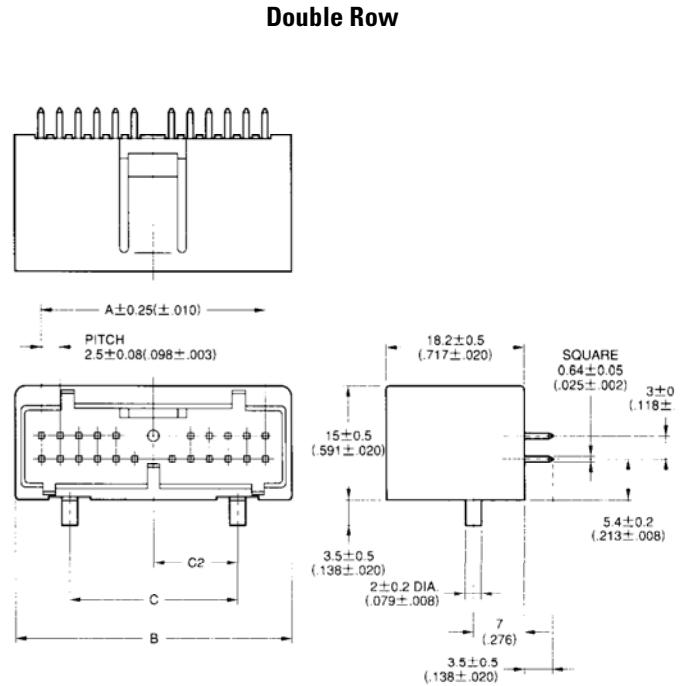

Double Row

Note: Configuration of mating area differs slightly depending on the number of contacts.

PCB Hole Pattern (Ref.)

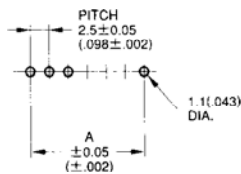

Configuration of Mating Area (Ref.)

No. of Contacts	Standard	Polarized Version
5		
6		

PCB Hole Pattern (Ref.)

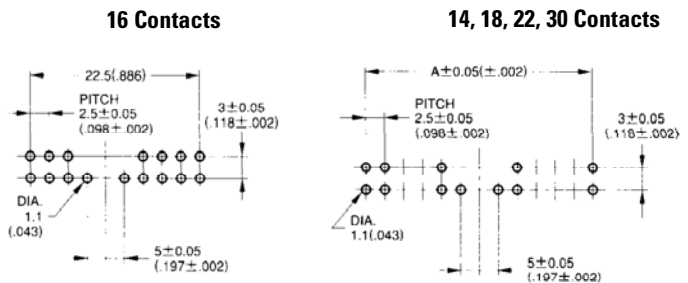

#### • Single Row

No. of Contacts	Part Number		A ± 0.25 (±.010)	B ± 0.5 (±.020)
	Standard	Polarized Version		
5	IL-AG5- 5P-S3T2	IL-AG5-5PK-S3T2-LB	10.0 (.394)	15.8 ( .622)
6	IL-AG5- 6P-S3T2	IL-AG5-6PK-S3T2-LB	12.5 (.492)	18.3 ( .720)
7	IL-AG5- 7P-S3T2	—	15.0 (.591)	20.8 ( .819)
10	IL-AG5-10P-S3T2	—	22.5 (.886)	28.3 (1.114)

#### • Double Row

No. of Contacts	Part Number	A	B	C	C2
		± 0.25 (±.010)	± 0.5 (±.020)	± 0.2 (±.008)	± 0.1 (±.004)
14	IL-AG5-14P-D3T2-A	20.0 ( .787)	26.5 (1.043)	12.5 ( .492)	6.25 ( .246)
16	IL-AG5-16P-D3T2-A	22.5 ( .886)	29.0 (1.142)	15.0 ( .591)	8.75 ( .344)
18	IL-AG5-18P-D3T2	25.0 ( .984)	31.5 (1.240)	17.5 ( .689)	8.75 ( .344)
22	IL-AG5-22P-D3T2	30.0 (1.181)	36.5 (1.437)	22.5 ( .886)	11.25 ( .443)
30	IL-AG5-30P-D3T2	40.0 (1.575)	46.5 (1.831)	30.0 (1.181)	15.00 ( .591)

Dimensions in mm (i)



# IL-AG5 SERIES AUTOMOTIVE CONNECTORS

## 025 Crimp Contacts, PCB-to-Cable/Cable-to-Cable Applications

### RIGHT ANGLE PIN HEADER

#### Single Row

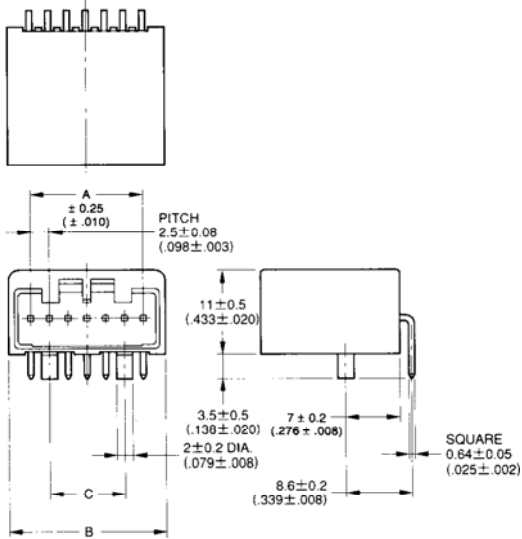

Note: Configuration of mating area slightly differs depending on the number of contacts.

#### Double Row

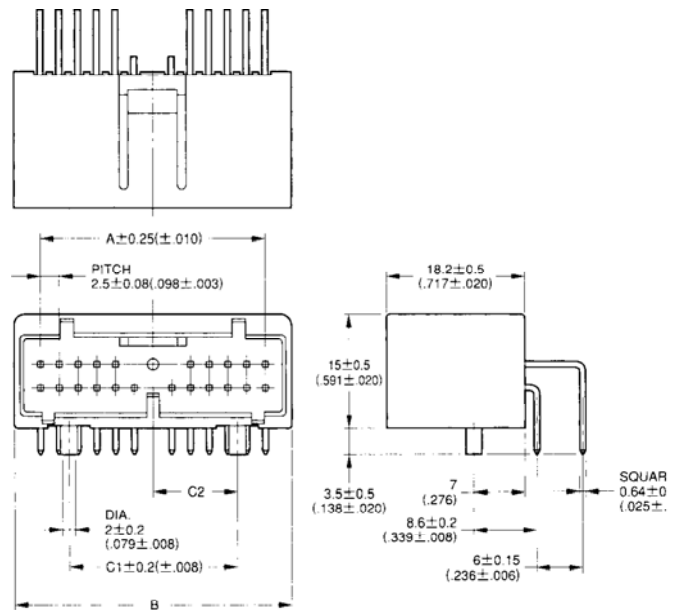

#### PCB Hole Pattern (Ref.)

#### PCB Hole Pattern (Ref.)

#### 5 Contacts

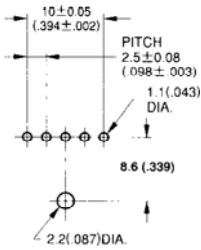

#### 6 Contacts

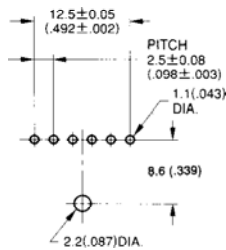

#### 7 Contacts

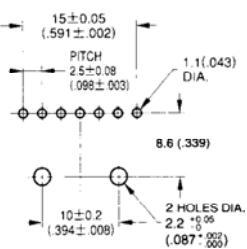

#### 10 Contacts

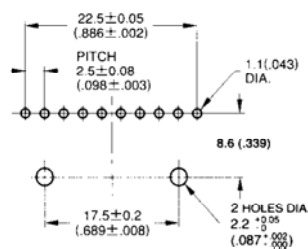

#### 16 Contacts

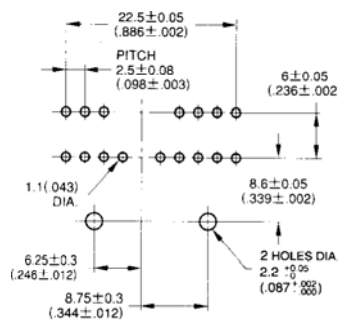

#### 14, 18, 22, 30 Contacts

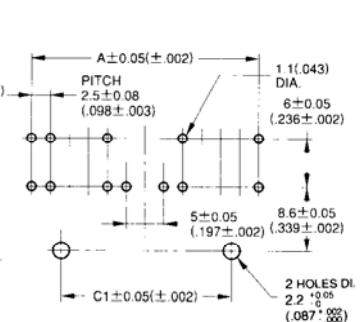

#### • Double Row

No. of Contacts	Part Number	A $\pm 0.25$ ( $\pm .010$ )	B $\pm 0.5$ ( $\pm .020$ )	C1 $\pm 0.2$ ( $\pm .008$ )	C2 $\pm 0.1$ ( $\pm .004$ )
14	IL-AG5-14P-D3L2-A	20.0 (.787)	26.5 (1.043)	12.5 (.492)	6.25 (.246)
16	IL-AG5-16P-D3L2-A	22.5 (.886)	29.0 (1.142)	15.0 (.591)	8.75 (.344)
18	IL-AG5-18P-D3L2	25.0 (.984)	31.5 (1.240)	17.5 (.689)	8.75 (.344)
22	IL-AG5-22P-D3L2	30.0 (1.181)	36.5 (1.437)	22.5 (.886)	11.25 (.443)
30	IL-AG5-30P-D3L2	40.0 (1.575)	46.5 (1.831)	30.0 (1.181)	15.00 (.591)

#### • Single Row

No. of Contacts	Part Number		A $\pm 0.25$ ( $\pm .010$ )	B $\pm 0.5$ ( $\pm .020$ )	C $\pm 0.2$ ( $\pm .008$ )
	Standard	Polarized Version			
5	IL-AG5- 5P-S3L2	IL-AG5-5PK-S3L2-LB	10.0 (.394)	15.8 (.622)	—
6	IL-AG5- 6P-S3L2	IL-AG5-6PK-S3L2-LB	12.5 (.492)	18.3 (.720)	—
7	IL-AG5- 7P-S3L2	—	15.0 (.591)	20.8 (.819)	10.0 (.394)
10	IL-AG5-10P-S3L2	—	22.5 (.886)	28.3 (1.114)	17.5 (.689)

Note: Refer to Socket Housing information for configuration of mating area of polarized version.

Dimensions in mm (inches).

# IL-AG5 SERIES AUTOMOTIVE CONNECTORS

## 025 Crimp Contacts, PCB-to-Cable/Cable-to-Cable Applications

### SOCKET HOUSING

#### Single Row

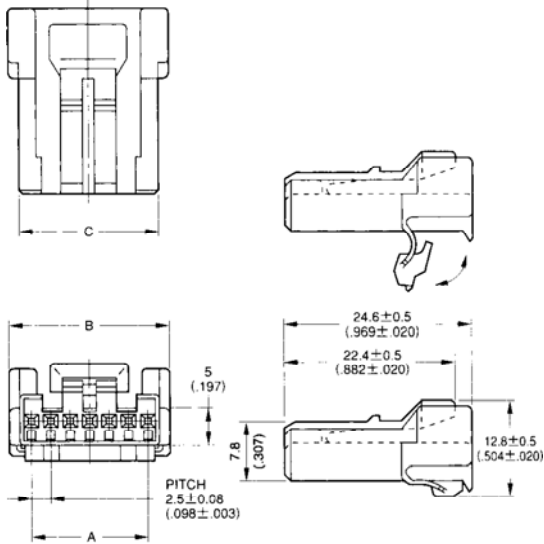

#### Double Row

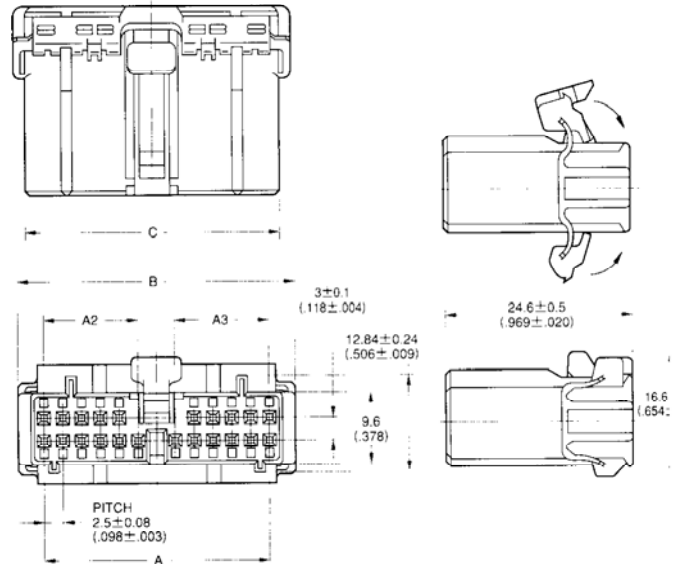

Configuration of Mating Area (Ref.)

No. of Contacts	Standard	Polarized Version
5		
6		

#### • Single Row

No. of Contacts	Part Number		A ± 0.25 (± .010)	B ± 0.5 (± .020)	C +0.14 (+.006) -0.25 (-.010)
	Standard	Polarized Version			
5	IL-AG5- 5S-S3C1	IL-AG5-5SK-S3C1-LB	10.0 (.394)	16.1 ( .634)	13.1 ( .516)
6	IL-AG5- 6S-S3C1	IL-AG5-6SK-S3C1-LB	12.5 (.492)	18.6 ( .732)	15.6 ( .614)
7	IL-AG5- 7S-S3C1	—	15.0 (.591)	21.1 ( .831)	18.1 ( .713)
10	IL-AG5-10S-S3C1	—	22.5 (.886)	28.6 (1.126)	25.6 (1.008)

#### • Double Row

No. of Contacts	Part Number	A ± 0.25 (± .010)	A2 ± 0.1 (± .004)	A3 ± 0.1 (± .004)	B ± 0.5 (± .020)	C +0.14 (+.006) -0.25 (-.010)
16	IL-AG5-16S-D3C1-A	22.5 ( .886)	10.0 ( .394)	7.5 ( .295)	29.2 (1.150)	26.2 (1.031)
18	IL-AG5-18S-D3C1	25.0 ( .984)	10.0 ( .394)	10.0 ( .394)	31.7 (1.248)	28.7 (1.130)
22	IL-AG5-22S-D3C1	30.0 (1.181)	12.5 ( .492)	12.5 ( .492)	36.7 (1.445)	33.7 (1.327)
30	IL-AG5-30S-D3C1	40.0 (1.575)	17.5 ( .689)	17.5 ( .689)	46.7 (1.839)	43.7 (1.720)

Dimensions in mm (inches).

# IL-AG5 SERIES AUTOMOTIVE CONNECTORS

## 025 Crimp Contacts, PCB-to-Cable/Cable-to-Cable Applications

### SOCKET CONTACT (CRIMP TYPE)

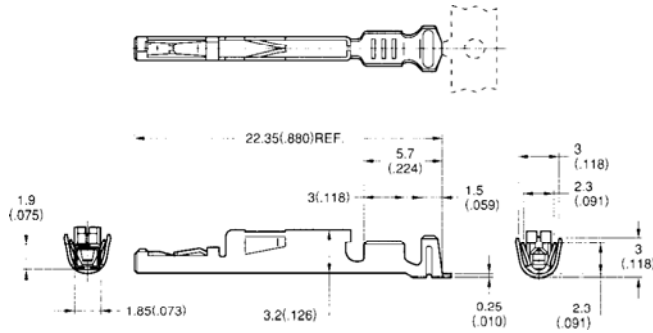

#### Tooling:

Semi-Automatic Crimping Machine: CT350-2 Type

Hand Crimping Tool: CT150 Type

Contact Extraction Tool: ET-AG5

Lock Flap Release Tool: RT-AG5 • EX5

Part Number (Note 1)	Finish (Note 2)	Applicable Wire (Stranded)				Applicable Tool	
		Type	AWG No.	Conductor Cross Section Area	Insulation Outer Dia.	Hand Crimp	Semi-Auto. CT350-2 type
IL-AG5-C1-5000	Tin	AV, AVS, AVSS	#22 to #20	0.3 to 0.5mm <sup>2</sup>	1.4 to 2.4mm (.055 to .094")	CT150-1-AG5	Applicator: 350-AG5-2 Press: CP210-1B
		AVS, AVSS	#18	0.85mm <sup>2</sup>			

Note 1: 5,000 pcs. per reel.

Note 2: The standard finish of contact is tin plating. Gold plating is available as an option.

For details, please consult JAE.

### CABLE PLUG

#### PIN HOUSING (22 contacts only)

Part Number: IL-AG5-22P-D3C1

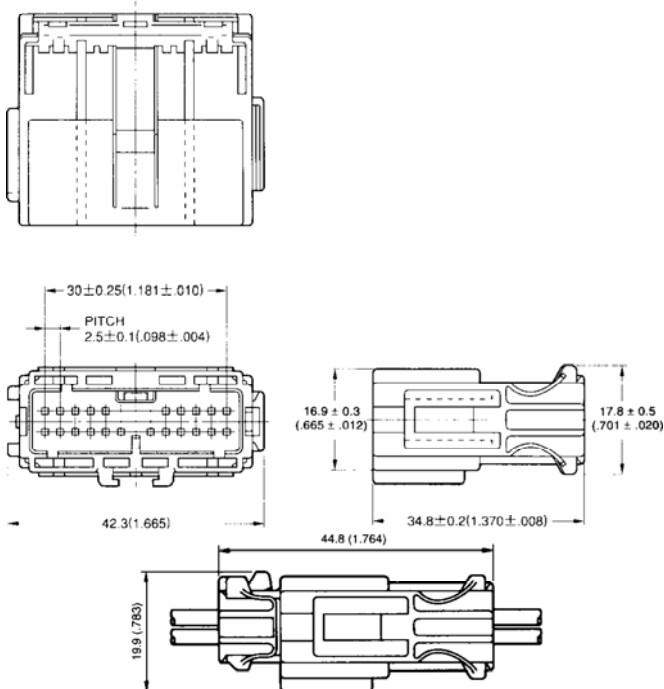

#### PIN CONTACT (CRIMP TYPE)

Part Number: IL-AG5-PC1-5000

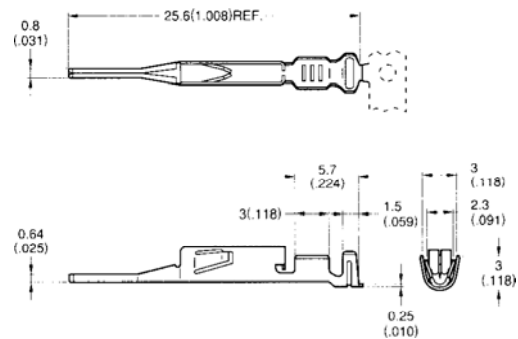

#### Applicable Wire (Stranded)

AWG No.	Conductor Cross Section Area	Insulation Outer Dia.
#22 to #18	0.3 to 0.85mm <sup>2</sup>	1.4 to 2.4mm (.055 to .094")

**Tool** (Please consult JAE for details.)

Hand Crimping Tool: CT150-1-AG-5

Contact Extraction Tool: EX-AG5

Lock Flap Release Tool: RT-AG5 • EX5

(Note: Contacts 5,000 pcs, per reel)

Dimensions in mm (inches).

## Looking for pricing, stock, or lifecycle information?

Click below to explore more details on WIN SOURCE:

 [View IL-AG5-C1-5000](#) on WIN SOURCE

 [JAE Electronics](#) Information

## Optimize Your Supply Chain with WIN SOURCE Solutions

-  Global Sourcing Solution
-  Obsolete Management
-  Cost Control Management
-  Shortage Management
-  Alternative Solution
-  Excess Inventory Management