



**THE DATASHEET OF
SEN55-SDN-T**



Datasheet SEN5x

Environmental Sensor Node for HVAC and Air Quality Applications

- PM, NO_x, VOC, RH & T sensor platform
- Fast & easy integration
- One driver for up to 8 data signals
- Superior sensing accuracy and lifetime
- Fully calibrated digital output



Overview

The SEN5x is a unique sensor module family combining the measurement of critical air quality parameters – particulate matter, VOC, NO_x, humidity, and temperature – in a single package. The modules are a result of Sensirion's extensive experience in environmental sensing and offers best possible performance of each sensing parameter, a superior lifetime, as well as a compact form factor. The SEN5x sensors provide fully calibrated outputs with a digital interface. The combination of all measurement parameters in a single device allows manufacturers of air quality devices to reduce design and integration efforts, shorten development times and simplify their supply chain. Proprietary algorithms enable straightforward integration into HVAC and air quality applications allowing resource/time savings and focus on core competencies. The implemented Sensirion Temperature Acceleration Routine (STAR) engine accelerates the device's response to ambient temperature change by a factor of 2-3 to provide better UX and more accurate measurements to end users.

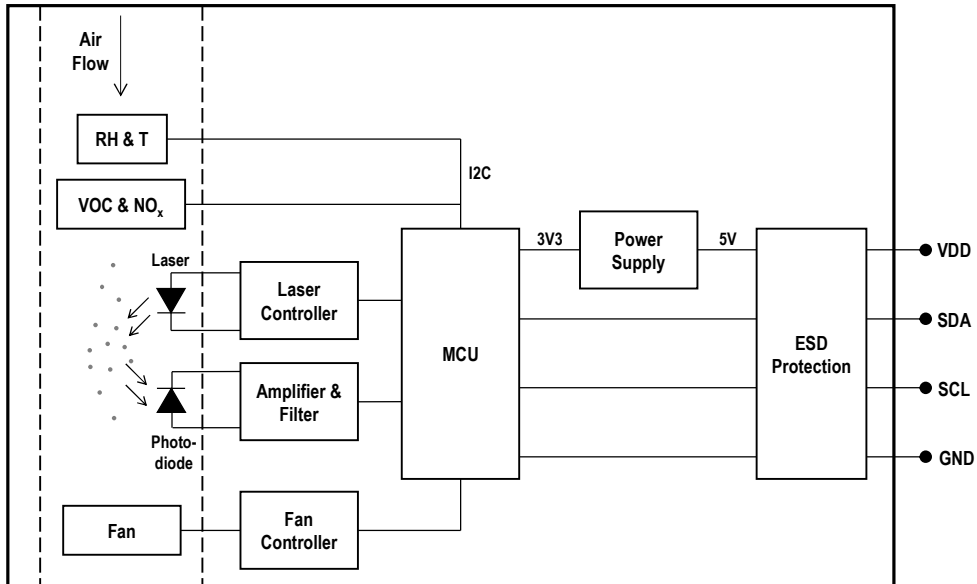

Figure 1 Functional block diagram of the SEN5x. The RH & T and VOC sensors are only contained in the SEN54 and SEN55, the NOx signal is only contained in the SEN55.

Content

1 Product Family Overview and Ordering Information	4
2 Environmental Sensor Node Specifications	5
3 Electrical Specifications	11
4 Hardware Interface Specifications	13
5 Functional Overview	14
6 Operation and Communication through the I ² C Interface	17
7 Technical Drawings	26
8 Revision History	28
9 Important Notices	29

1 Product Family Overview and Ordering Information

The SEN5x product family consists of a lineup of sensors with identical dimensions, identical hardware & firmware interface, and varying number of sensor outputs. **Table 1** gives an overview of all available product variants with their respective sensor outputs.

Specifications and commands for sensor inputs/outputs only apply for the given product if the sensor output is part of this product.

Products	Sensor outputs	Description	Article Number
SEN50-SDN-T	Particulate Matter	Particulate matter sensor, tray packaging, 45 pcs. per tray	3.000.667
SEN54-SDN-T	Particulate Matter Relative Humidity Temperature VOC Index	Environmental sensor node, tray packaging, 45 pcs. per tray	3.000.535
SEN55-SDN-T	Particulate Matter Relative Humidity Temperature VOC Index NO _x Index	Environmental sensor node, tray packaging, 45 pcs. per tray	3.000.593

Table 1: Sensor module specifications.

2 Environmental Sensor Node Specifications

Default conditions of standard Measurement-Mode (6.1.1), 25 °C and 5 V supply voltage apply to values in the table below, unless otherwise stated.

2.1 Sensor Module Specifications

Parameter	Conditions	Value	Units
Sampling interval	-	1 ± 0.03	s
Lifetime ¹	24 h/day operation	> 10	years
Acoustic emission level	0.2 m	24	dB(A)
Long term acoustic emission level drift	0.2 m	+0.5	dB(A) / year
Weight	-	36.4 ± 10%	g

Table 2: Sensor module specifications.

¹ Lifetime is based on mean-time-to-failure (MTTF) calculation. Lifetime might vary depending on different operating conditions.

2.2 Particulate Matter Specifications

Parameter	Conditions	Value	Units
Mass concentration specified range	-	0 to 1'000	µg/m ³
Mass concentration size range	PM1.0	0.3 to 1.0	µm
	PM2.5	0.3 to 2.5	µm
	PM4	0.3 to 4.0	µm
	PM10	0.3 to 10.0	µm
Mass concentration precision ^{2,3} for PM1 and PM2.5 ⁴	0 to 100 µg/m ³	±5 µg/m ³ AND 5 % m.v.	
	100 to 1000 µg/m ³	±10	% m.v.
Mass concentration precision ^{2,3} for PM4, PM10 ⁵	0 to 100 µg/m ³	±25	µg/m ³
	100 to 1000 µg/m ³	±25	% m.v.
Maximum long-term mass concentration precision limit drift	0 to 100 µg/m ³	±1.25	µg/m ³ / year
	100 to 1000 µg/m ³	±1.25	% m.v. / year
Typical start-up time ⁶	number concentration	200 – 3000 #/cm ³	8 s
		100 – 200 #/cm ³	16 s
		50 – 100 #/cm ³	30 s
Sensor output characteristics	PM2.5 mass concentration	Calibrated to TSI DustTrak™ DRX 8533 Ambient Mode	
Additional T-dependent mass precision limit drift ³	temperature difference to 25°C	typ.	±0.5 % m.v. / °C
Laser wavelength (DIN EN 60825-1 Class 1)		typ.	660 nm

Table 3: Particulate matter sensor specifications. Default conditions of 25±2 °C, 50±10% relative humidity and 5 V supply voltage apply unless otherwise stated. 'max.' means 'maximum', 'typ.' means 'typical', '% m.v.' means '% of measured value'.

² Also referred to as "between-parts variation" or "device-to-device variation".

³ For further details, please refer to the document "Sensirion Particulate Matter Sensor Specification Statement".

⁴ Verification Aerosol for PM2.5 is a 3% atomized KCl solution. Deviation to reference instrument is verified in end-tests for every sensor after calibration.

⁵ PM4 and PM10 output values are calculated based on distribution profile of all measured particles.

⁶ Time after starting Measurement-Mode, until a stable measurement is obtained.

2.3 Temperature and Humidity Specifications

Parameter	Conditions	Value ⁷	Units
Compensated outputs ⁸	-	Temperature and Relative Humidity	°C %RH
Typical accuracy temperature	@ 15-30 °C, 50 %RH	±0.45	°C
Max. accuracy temperature	@ 15-30 °C, 50 %RH	±0.7	°C
Repeatability temperature	@ 25 °C, 50 %RH	0.1	°C
Response time temperature ⁹	@ 25 °C, 50 %RH, τ 63%	< 60	s
Typical accuracy relative humidity	@ 25 °C, 30-70 %RH	±4.5	%RH
Max. accuracy relative humidity	@ 25 °C, 30-70 %RH	±6	%RH
Repeatability relative humidity	@ 25 °C, 50 %RH	±1	%RH
Response time relative humidity ¹⁰	@ 25 °C, 50 %RH, τ 63%	< 20	s

Table 4: Temperature and humidity specifications.

⁷ For the definition of the typical and max. accuracy tolerance, please refer to the document "Sensirion Humidity Sensor Specification Statement".

⁸ Self-heating of the module is compensated according to the application note "Temperature Acceleration and Compensation Instructions for SEN5x".

⁹ For a step from 15°C to 25°C

¹⁰ For a step from 75%RH to 25%RH

2.4 Gas Specifications

Parameter	Comments	Values			Units	
		Min.	Typ. ¹¹	Max.		
Output signals	VOC Index	1	–	500	VOC Index points	
	NO _x Index	1	–	500	NO _x Index points	
Device-to-device variation	VOC Index ¹²	–	<±15 <±15	–	VOC Index points or % VOC Index m.v. (the larger)	
	NO _x Index ¹²	–	<±50 <±50	–	NO _x Index points or % NO _x Index m.v. (the larger)	
Repeatability	VOC Index ¹²	–	<±5 <±5	–	VOC Index points or % VOC Index m.v. (the larger)	
	NO _x Index ¹²	–	<±10 <±10	–	NO _x Index points or % NO _x Index m.v. (the larger)	
Response time	Changing concentration from 5 to 10 ppm of ethanol, at sampling interval of 1 s	τ ₆₃	–	<10	–	s
		τ ₉₀	–	<30	–	s
Switch-on behavior	Time until reliably detecting events ¹³	–	<60	–	s	
	Time until specifications in this table are met	VOC Index	<1	–	h	
		NO _x Index	<6	–	h	

Table 5: Gas sensing specifications at 25 °C and 50 % RH in zero air (considered as clean air for indoor air quality applications). All concentrations refer to ethanol as test gas.

¹¹ 95 % of the sensors will be within the typical tolerance corresponding to 2σ assuming a normal distribution for ≥100 sensors.

¹² Evaluated using the calibration and test sequence according to the application note *SGP40 – Testing Guide*.

¹³ Signal change during 60-s event of 5000 to 10000 ppb of ethanol or of 100 to 300 ppb of NO₂ is three times larger than raw signals drift, without this event during the same duration.

2.5 Recommended and Absolute Maximum/Minimum Operating and Storage Conditions

The SEN5x contains different sensing components with different recommended operating and storage ranges. To ensure an optimal performance of the SEN5x, the “SEN5x Handling Instructions” as well as the “SEN5x Mechanical Assembly and Design-in Guidelines” need to be followed.

2.5.1 SEN54 and SEN55

Table 6 and Figure 2 show the recommended operating and storage conditions in which all the sensing components of the SEN54 and SEN55 show best performance, as well as absolute maximum/minimum conditions which must not be exceeded. Gas sensing specifications are guaranteed only when the SEN54 and SEN55 are operated and stored under the recommended conditions given in Table 6.

Exposure to conditions outside the recommended range may temporarily reduce sensor performance (reversible RH drift, reduced RH, T, gas, PM accuracy). Exposure to conditions outside absolute maximum/minimum range may lead to permanently reduced sensor performance (gas sensitivity drift) or cause permanent damage to the device.

The sensor must not be exposed towards condensing conditions at any time.

Condition	Parameter	Recommended		Absolute Maximum/Minimum		Unit
		Min.	Max.	Min.	Max.	
Operating conditions	Temperature	10	40	-10	50	°C
	Relative humidity	20	80	0	90 (non-condensing)	% RH
Storage conditions	Temperature	10	30	-40	70	°C
	Relative Humidity	20	60	0	80 (non-condensing)	% RH

Table 6 Recommended and absolute maximum/minimum operating and storage conditions for SEN54 and SEN55.

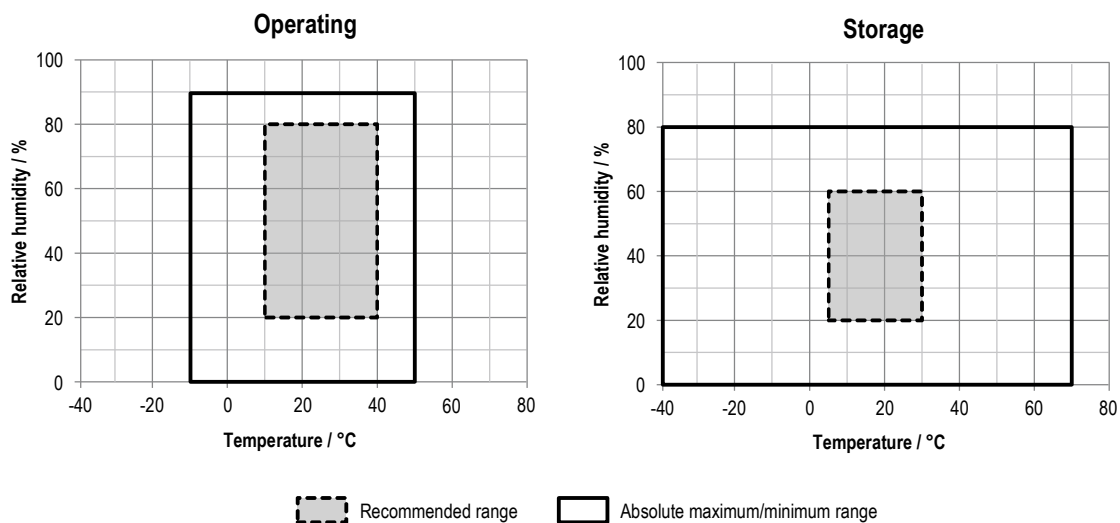

Figure 2 Recommended and absolute maximum/minimum operating and storage conditions for SEN54 and SEN55.

2.5.2 SEN50

Table 7 and **Figure 3** show the recommended operating and storage conditions in which all the sensing components of the SEN50 shows the best performance, as well as absolute maximum/minimum conditions which must not be exceeded.

Exposure to conditions outside the recommended range may temporarily reduce sensor performance (PM accuracy). Exposure to conditions outside absolute maximum/minimum range may lead to permanently reduced sensor performance (gas sensitivity drift) or cause permanent damage to the device.

The sensor must not be exposed towards condensing conditions at any time.

Condition	Parameter	Recommended		Absolute Maximum/Minimum		Unit
		Min.	Max.	Min.	Max.	
Operating conditions	Temperature	10	40	-10	60	°C
	Relative humidity	20	80	0	95 (non-condensing)	% RH
Storage conditions	Temperature	10	30	-40	70	°C
	Relative Humidity	20	60	0	95 (non-condensing)	% RH

Table 7 Recommended and absolute maximum/minimum operating and storage conditions for SEN50.

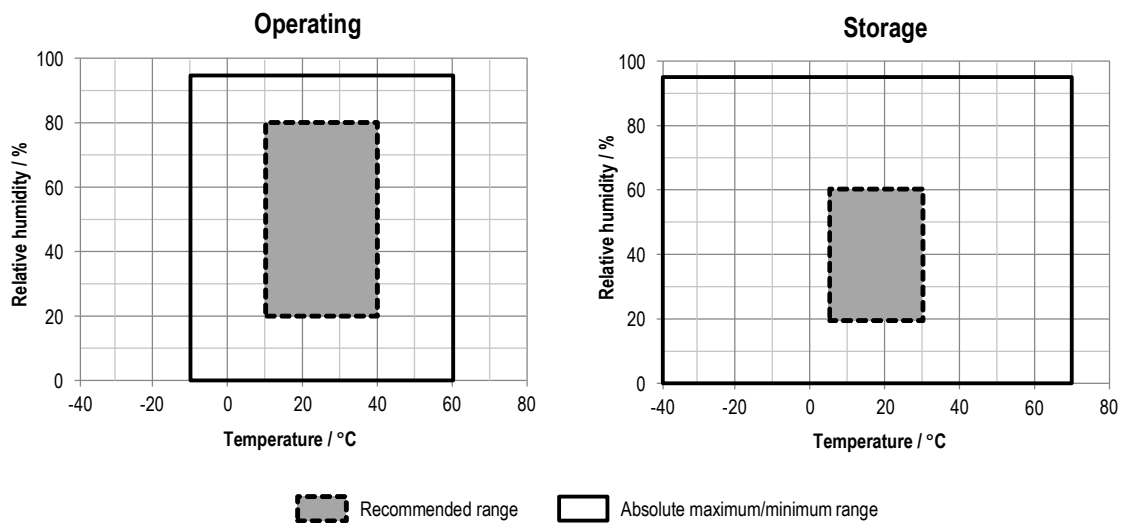

Figure 3 Recommended and absolute maximum/minimum operating and storage conditions for SEN50.

3 Electrical Specifications

3.1 Electrical Characteristics

Parameter	Conditions	Min	Typ	Max	Unit	
Supply voltage	-	4.5	5.0	5.5	V	
Sensor startup time (Time after power-on until I2C communication can be started)	-	-	-	50	ms	
Average supply current	Idle Mode (first 10 seconds)	SEN55	-	3.8	4.2	mA
		SEN54	-	0.7	1	
		SEN50	-	0.7	1	
	Idle Mode (after first 10 seconds)	SEN55	-	2.6	3	
		SEN54	-	0.7	1	
		SEN50	-	0.7	1	
	RHT/Gas-only Measurement Mode	SEN55	-	6.8	8	
		SEN54	-	6.5	7.7	
	Measurement-Mode (first 60 seconds)	SEN55	-	70	100	
		SEN54	-	70	100	
		SEN50	-	70	100	
	Measurement-Mode (after first 60 seconds)	SEN55	-	63	80	
SEN54		-	63	80		
SEN50		-	63	80		
Peak supply current	Measurement mode (pulse width of 16 μ s)	-	100	110	mA	
Input high level voltage (V _{IH})	-	2.31	-	5.5	V	
Input low level voltage (V _{IL})	-	0	-	0.99		
Output low level voltage (V _{OL})	Sink current <6mA	0	0	0.4		

Table 8 Electrical specifications at 25°C.

3.2 Absolute Maximum Ratings

Stress levels beyond those listed in Table 9 may cause permanent damage to the device. These are stress ratings only and functional operation of the device at these conditions cannot be guaranteed. Exposure to the absolute maximum rating conditions for extended periods may affect the reliability of the device.

Parameter	Min	Max	Unit
Supply voltage VDD	-0.3	5.5	V
Interface Select SEL	-0.3	5.5	
I/O pins (RX/SDA, TX/SCL)	-0.3	5.5	
Max. current on any I/O pin	-16	16	mA
Operating temperature range	see Table 6		
Operating humidity range	see Table 6		
Storage temperature range (short-term, e.g. transport)	see Table 6		
Storage humidity range (short-term, e.g. transport)	see Table 6		

Table 9: Absolute minimum and maximum ratings.

3.3 ESD / EMC Ratings

Immunity

Description	Standard	Rating
Electro Static Discharge	IEC 61000-4-2	±4 kV contact, ±8 kV air
Power-Frequency Magnetic Field	IEC 61000-4-8	30A/m, 50Hz and 60Hz
Radio-Frequency EM-Field AM-modulated	IEC 61000-4-3	80MHz - 1000MHz, 3V/m, 80% AM @1kHz
Radio-Frequency EM-Field AM-modulated	IEC 61000-4-3	1.4GHz – 6GHz, 3V/m, 80% AM @1kHz

Emission

Description	Standard	Rating
Emission in SAC for 30MHz to 230MHz	IEC/CISPR 16	40dB(µV/m) QP @3m
Emission in SAC for 230MHz to 1000MHz	IEC/CISPR 16	47dB(µV/m) QP @3m

4 Hardware Interface Specifications

The sensor is equipped with a serial communication interface. The interface connector is located at the side of the sensor adjacent to the air outlet. The used connector is ACES 51451-0060N-001 on the sensor's side, while the corresponding plug is ACES 51452-006H0H0-001. At the time of writing JST GHR-06V-S is compatible and can be used as well. In **Table 11**, a description of the pin layout is given.

Part	Connector
Sensor side	ACES 51451-0060N-001
Cable side	Compatible with ACES 51452-006H0H0-001 (e.g., JST GHR-06V-S)

Table 10: SEN5x connector

Pin	Name	Description	Comments
1	VDD	Supply voltage	5V ± 10%
2	GND	Ground	
3	SDA	Serial data input / output	LVTTL 3.3V compatible
4	SCL	Serial clock input	LVTTL 3.3V compatible
5	SEL	Interface select	Connect to GND
6	NC	Do not connect	

Table 11: SEN5x pin assignment.

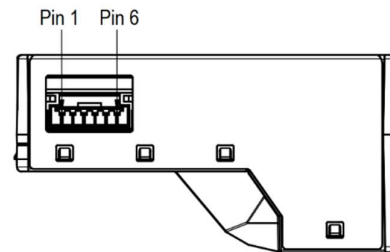

Figure 4 Pin layout. The communication interface connector (ACES 51451-0060N-001) is located at the side of the sensor adjacent to the air outlet.

Note, that there is an internal electrical connection between GND pin (2) and metal shielding. Keep this metal shielding electrically floating to avoid any unintended currents through this internal connection. If this is not an option, proper external potential equalization between GND pin and any potential connected to the shielding is mandatory. Any current through the connection between GND and metal shielding may damage the product and poses a safety risk through overheating.

5 Functional Overview

5.1 Operating Modes

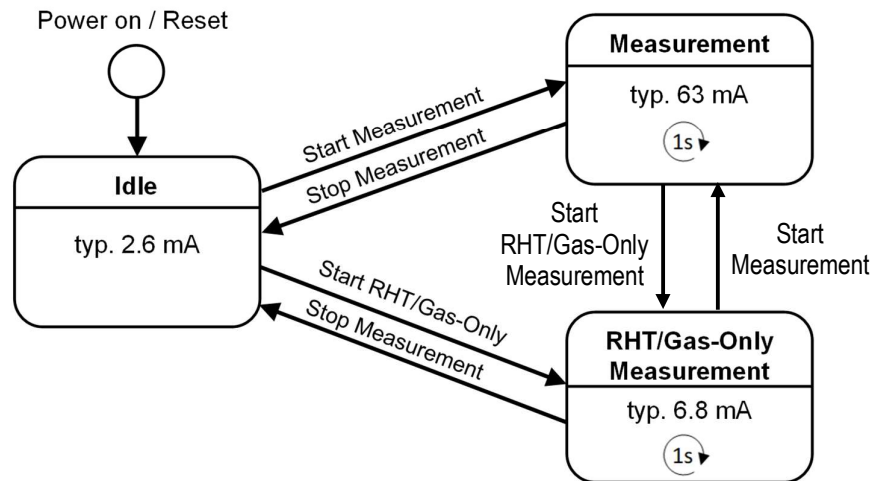

Figure 5 SEN5x operating modes. The RHT/Gas-Only Measurement Mode is applicable for SEN55 and SEN54 only. The direct switch between Measurement and RHT/Gas-Only Measurement mode is available only for firmware version v2 and newer.

Idle

- The module is in Idle Mode after power on or reset.
- Most of the internal electronics switched off /reduced power consumption.
- Fan and laser are switched off.
- The module is ready to receive and process any command.

Measurement

- All electronics switched on / max. power consumption.
- The measurement is running, and the module is continuously processing measurement data.
- New readings are available every second.

RHT/Gas-Only Measurement

- The RHT/Gas-Only Measurement mode can be entered from Idle and the Measurement modes. The direct switch between Measurement and RHT/Gas-Only Measurement mode is available only for firmware version v2 and newer.
- Fan and laser are switched off for reduced power consumption.
- RHT and gas sensor are switched on. RHT and gas measurement is running, and the module is continuously processing measurement data.
- New readings are available every second.
- The PM output is 0xFFFF

5.2 Fan Auto Cleaning

When the module is in Measurement-Mode an automatic fan-cleaning procedure will be triggered periodically following a defined cleaning interval. This will accelerate the fan to maximum speed for 10 seconds to blow out the accumulated dust inside the fan.

- Measurement values are not updated while the fan-cleaning is running.
- The cleaning interval is set to 604'800 seconds (i.e., 168 hours or 1 week) with a tolerance of $\pm 3\%$.
- The interval can be configured using the Set Automatic Cleaning Interval command.
- Set the interval to 0 to disable the automatic cleaning.
- A sensor reset, resets the cleaning interval to its default value
- If the sensor is switched off, the time counter is reset to 0. Make sure to trigger a cleaning cycle at least every week if the sensor is switched off and on periodically (e.g., once per day).
- The cleaning procedure can also be started manually with the Start Cleaning command.

5.3 Temperature compensation

By default, the temperature and humidity outputs from the sensor are compensated for the modules self-heating. If the module is designed into a device, the temperature compensation might need to be adapted to incorporate the change in thermal coupling and self-heating of other device components.

A guide to achieve optimal performance, including references to mechanical design-in examples can be found in the app note "Temperature Acceleration and Compensation Instructions for SEN5x" at www.sensirion.com.

5.4 Device Status Register

The Device Status Register is a 32-bit register that contains information about the internal state of the module.

31	30	29	28	27	26	25	24	23	22	21	20	19	18	17	16
										Warning		Info			
res.	res.	res.	res.	res.	res.	res.	res.	res.	res.	SPEED	res.	FAN	res.	res.	res.
15	14	13	12	11	10	9	8	7	6	5	4	3	2	1	0
								Error	Error	Error	Error				
	res.	res.	res.	res.	res.	res.	res.	GAS SENSOR	RHT	LASER	FAN	res.	res.	res.	res.

Note: All "res." bits are reserved for internal use or future versions. These bits can be both 0 and 1 and should therefore be ignored.

Bit 21 **SPEED**: Fan speed out of range

- 0: Fan speed is ok.
- 1: Fan speed is too high or too low.

- During the first 3 seconds after starting the measurement (fan start-up) the fan speed is not checked.
- The fan speed is also not checked during the auto cleaning procedure.
- Apart from the two exceptions mentioned above, the fan speed is checked once per second in the measurement mode. If it is out of range twice in succession, the SPEED-bit is set.
- At very high or low ambient temperatures, the fan may take longer to reach its target speed after start-up. In this case, the bit will be set. As soon as the target speed is reached, this bit is cleared automatically.
- If this bit is constantly set, this indicates a problem with the power supply or that the fan is no longer working properly

Bit 19 **FAN:** Fan cleaning active

- 0: Fan is running normal.
- 1: Active during the automatic cleaning procedure of the fan

Bit 7 **GAS SENSOR:** Gas sensor error (VOC & NOx)

- 0: Gas sensor is running normal.
- 1: Gas sensor error

Bit 6 **RHT:** RHT communication error

- 0: RHT sensor is running normal.
- 1: Error in internal communication with the RHT sensor

Bit 5 **LASER:** Laser failure

- 0: Laser current is ok.
- 1: Laser is switched on and current is out of range.
- The laser current is checked once per second in the measurement mode. If it is out of range, the LASER-bit is set.
- If the laser current is back within limits, this bit will be not cleared automatically.
- A laser failure can occur at very high temperatures outside of specifications or when the laser module is defective.

Bit 4 **FAN:** Fan failure, fan is mechanically blocked or broken.

- 0: Fan works as expected.
- 1: Fan is switched on, but the measured fan speed is 0 RPM.
- The fan is checked once per second in the measurement mode. If 0 RPM is measured twice in succession, the FAN bit is set.
- The FAN-bit will not be cleared automatically.
- A fan failure can occur if the fan is mechanically blocked or broken.

6 Operation and Communication through the I²C Interface

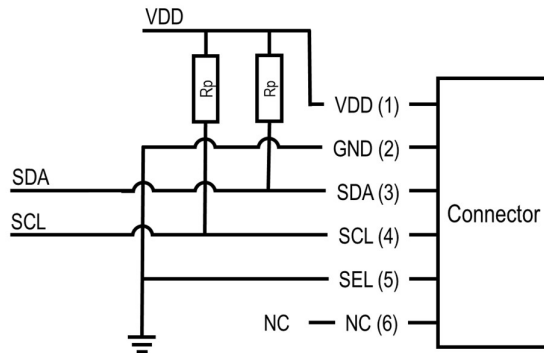

Usage:

- I²C address: 0x69
- Max. speed: standard mode, 100 kbit/s
- Clock stretching: not used

Both SCL and SDA lines are open drain I/Os. They should be connected to external pull-up resistors (e.g. $R_p = 10\text{ k}\Omega$). **Important notice:** in order to correctly select I²C as interface, the interface select (SEL) pin must be pulled to GND before or at the same time the sensor is powered up.

Figure 6: Typical I²C application circuit.

To avoid electromagnetic interference and crosstalk, use as short as possible electronic connections (< 10 cm) and/or well shielded connection cables.

For detailed information on the I²C protocol, refer to NXP I²C-bus specification¹⁴.

Checksum Calculation

The Read and Write Commands transmit the data in 2-byte packets, followed by an 8-bit checksum. The checksum is calculated as follows:

Property	Value
Name	CRC-8
Protected Data	read and/or write data
Width	8 bit
Polynomial	$0x31 (x^8 + x^5 + x^4 + 1)$
Initialization	0xFF
Reflect Input	false
Reflect Output	false
Final XOR	0x00
Example	CRC(0xBEEF) = 0x92

```
uint8_t CalcCrc(uint8_t data[2]) {
    uint8_t crc = 0xFF;
    for(int i = 0; i < 2; i++) {
        crc ^= data[i];
        for(uint8_t bit = 8; bit > 0; --bit) {
            if(crc & 0x80) {
                crc = (crc << 1) ^ 0x31u;
            } else {
                crc = (crc << 1);
            }
        }
    }
    return crc;
}
```

Please note that the checksums are used only for the 2-byte data packets. The command code itself already contains a 3-bit CRC and therefore no checksum must be appended to it.

¹⁴ http://www.nxp.com/documents/user_manual/UM10204.pdf

6.1 I²C Commands

The following table shows an overview of the available I²C commands.

Address Pointer	Command Name	Communication	Command execution time
0x0021	Start Measurement	Write Data	< 50 ms
0x0037	Start Measurement in RHT/Gas-Only Measurement Mode	Write Data	< 50 ms
0x0104	Stop Measurement	Write Data	< 200 ms
0x0202	Read Data-Ready Flag	Read/ Write Data	< 20 ms
0x03C4	Read Measured Values	Read/ Write Data	< 20 ms
0x60B2	Read/ Write Temperature Compensation Parameters	Read/ Write Data and Parameters	< 20 ms
0x60C6	Read/ Write Warm Start Parameters	Read/ Write Data and Parameters	< 20 ms
0x60D0	Read/Write VOC Algorithm Tuning Parameters	Read/ Write Data and Parameters	< 20 ms
0x60E1	Read/Write NOx Algorithm Tuning Parameters	Read/ Write Data and Parameters	< 20 ms
0x60F7	Read/Write RHT/T Acceleration Mode	Read/ Write Data and Parameters	< 20 ms
0x6181	Read/Write VOC Algorithm State	Read/ Write Data and Parameters	< 20 ms
0x5607	Start Fan Cleaning	Write Data	< 20 ms
0x8004	Read/Write Auto Cleaning Interval	Read/ Write Data and Parameters	< 20 ms
0xD014	Read Product Name	Read/ Write Data	< 20 ms
0xD033	Read Serial Number	Read/ Write Data	< 20 ms
0xD100	Read Firmware Version	Read/ Write Data	< 20 ms
0xD206	Read Device Status	Read/ Write Data	< 20 ms
0xD210	Clear Device Status	Write Data	< 20 ms
0xD304	Reset	Write Data	< 100 ms

Table 12: Reference table for I²C commands.

Please note that all commands are volatile.

6.1.1 Start Measurement (0x0021)

Starts the measurement. After power up, the module is in Idle-Mode. Before any measurement values can be read, the Measurement-Mode needs to be started using this command.

6.1.2 Start Measurement in RHT/Gas-Only Measurement Mode (0x0037)

Starts a continuous measurement without PM. Only humidity, temperature, VOC, and NOx are available in this mode. Laser and fan are switched off to keep power consumption low.

6.1.3 Stop Measurement (0x0104)

Stops the measurement. Use this command to return to the initial state (Idle-Mode).

6.1.4 Read Data-Ready Flag (0x0202)

This command can be used for polling to find out when new measurements are available.

Read/Write Data:

Byte #	Description
0	unused, always 0x00
1	Data-Ready Flag 0x00: no new measurements available 0x01: new measurements ready to read
2	Checksum for bytes 0, 1

6.1.5 Read Measured Values (0x03C4)

Reads the measured values from the sensor module and resets the “Data-Ready Flag”. If the sensor module is in Measurement-Mode, an updated measurement value is provided every second and the “Data-Ready Flag” is set. If no synchronized readout is desired, the “Data-Ready Flag” can be ignored. The command “Read Measured Values” always returns the latest measured values. After sending the “Read Measured Values” command, a wait time of 10 ms is needed so that the sensor internally can fill the data buffers. After 20 ms, the read data header can be sent to read out the sensor data. In RHT/Gas-Only Measurement Mode, the PM output is 0xFFFF. If any value is unknown, 0xFFFF is returned.

Command	Returned data
0x03C4	PM Mass concentration, Relative humidity, Temperature, VOC Index, NOx Index

Read/Write Data:

Byte #	Datatype	Scale factor	Description
0..1	big-endian, uint16	10	Mass Concentration PM1.0 [$\mu\text{g}/\text{m}^3$]
2	Checksum for bytes 0, 1		
3..4	big-endian, uint16	10	Mass Concentration PM2.5 [$\mu\text{g}/\text{m}^3$]
5	Checksum for bytes 3, 4		
6..7	big-endian, uint16	10	Mass Concentration PM4.0 [$\mu\text{g}/\text{m}^3$]
8	Checksum for bytes 6, 7		
9..10	big-endian, uint16	10	Mass Concentration PM10 [$\mu\text{g}/\text{m}^3$]
11	Checksum for bytes 9, 10		
12..13	big-endian, int16	100	Compensated Ambient Humidity [%RH]
14	Checksum for bytes 12, 13		
15..16	big-endian, int16	200	Compensated Ambient Temperature [$^{\circ}\text{C}$]
17	Checksum for bytes 15, 16		
18..19	big-endian, int16	10	VOC Index
20	Checksum for bytes 18, 19		
21..22	big-endian, int16	10	NOx Index
23	Checksum for bytes 21, 22		

6.1.6 Read/ Write Temperature Compensation Parameters (0x60B2)

These commands allow to compensate temperature effects of the design-in at customer side by applying a custom temperature offset to the ambient temperature. The compensated ambient temperature is calculated as follows:

$$T_Ambient_Compensated = T_Ambient + (slope * T_Ambient) + offset$$

Where slope and offset are the values set with this command, smoothed with the specified time constant. The time constant is how fast the slope and offset are applied. After the specified value in seconds, 63% of the new slope and offset are applied.

More details about the tuning of these parameters are included in the application note "Temperature Acceleration and Compensation Instructions for SEN5x".

All temperatures (T_Ambient_Compensated, T_Ambient and offset) are represented in °C.

Read/Write Data and Parameters:

Byte #	Datatype	Scale factor	Description
0..1	big-endian, int16	200	Temperature offset [°C] (default value: 0)
2	Checksum for bytes 0, 1		
3..4	big-endian, int16	10000	Normalized temperature offset slope (default value: 0)
5	Checksum for bytes 3, 4		
6..7	big-endian, uint16	1	Time constant in seconds (default value: 0)
8	Checksum for bytes 6, 7		

6.1.7 Read/ Write Warm Start Parameter (0x60C6)

The temperature compensation algorithm is optimized for a cold start by default, i.e., it is assumed that the "Start Measurement" commands are called on a device not yet warmed up by previous measurements. If the measurement is started on a device that is already warmed up, this parameter can be used to improve the initial accuracy of the ambient temperature output. This parameter can be gotten and set in any state of the device, but it is applied only the next time starting a measurement, i.e., when sending a "Start Measurement" command. So, the parameter needs to be written before a warm-start measurement is started.

Read/Write Data and Parameters:

Byte #	Datatype	Scale factor	Description
0..1	big-endian, uint16	1	Warm start behavior as a value in the range from 0 (cold start, default value) to 65535 (warm start). (default value: 0)
2	Checksum for bytes 0, 1		

6.1.8 Read/ Write VOC Algorithm Tuning Parameters (0x60D0)

The VOC algorithm can be customized by tuning 6 different parameters. More details on the tuning instructions are provided in the application note “Engineering Guidelines for SEN5x”. Note that this command is available only in idle mode. In measure mode, this command has no effect. In addition, it has no effect if at least one parameter is outside the specified range.

Read/Write Data and Parameters:

Byte #	Datatype	Scale factor	Description
0..1	big-endian, int16	1	Index Offset VOC index representing typical (average) conditions. Allowed values are in range 1..250. The default value is 100.
2	Checksum for bytes 0, 1		
3..4	big-endian, int16	1	Learning Time Offset Hours Time constant to estimate the VOC algorithm offset from the history in hours. Past events will be forgotten after about twice the learning time. Allowed values are in range 1..1000. The default value is 12 hours.
5	Checksum for bytes 3, 4		
6..7	big-endian, int16	1	Learning Time Gain Hours Time constant to estimate the VOC algorithm gain from the history in hours. Past events will be forgotten after about twice the learning time. Allowed values are in range 1..1000. The default value is 12 hours.
8	Checksum for bytes 6, 7		
9..10	big-endian, int16	1	Gating Max Duration Minutes Maximum duration of gating in minutes (freeze of estimator during high VOC index signal). Zero disables the gating. Allowed values are in range 0..3000. The default value is 180 minutes.
11	Checksum for bytes 9, 10		
12..13	big-endian, int16	1	Std Initial Initial estimate for standard deviation. Lower value boosts events during initial learning period, but may result in larger device-to-device variations. Allowed values are in range 10..5000. The default value is 50.
14	Checksum for bytes 12, 13		
15..16	big-endian, int16	1	Gain Factor Gain factor to amplify or to attenuate the VOC index output. Allowed values are in range 1..1000. The default value is 230.
17	Checksum for bytes 15, 16		

6.1.9 Read/ Write NOx Algorithm Tuning Parameters (0x60E1)

The NOx algorithm can be customized by tuning 6 different parameters. More details on the tuning instructions are provided in the application note “Engineering Guidelines for SEN5x”. This command is available only in idle mode. In measure mode, this command has no effect. In addition, it has no effect if at least one parameter is outside the specified range.

Read/Write Data and Parameters:

Byte #	Datatype	Scale factor	Description
0..1	big-endian, int16	1	Index Offset NOx index representing typical (average) conditions. Allowed values are in range 1..250. The default value is 1.
2	Checksum for bytes 0, 1		
3..4	big-endian, int16	1	Learning Time Offset Hours Time constant to estimate the NOx algorithm offset from the history in hours. Past events will be forgotten after about twice the learning time. Allowed values are in range 1..1000. The default value is 12 hours.
5	Checksum for bytes 3, 4		
6..7	big-endian, int16	1	Learning Time Gain Hours The time constant to estimate the NOx algorithm gain from the history has no impact for NOx. This parameter is still in place for consistency reasons with the VOC tuning parameters command. This parameter must always be set to 12 hours.
8	Checksum for bytes 6, 7		
9..10	big-endian, int16	1	Gating Max Duration Minutes Maximum duration of gating in minutes (freeze of estimator during high NOx index signal). Set to zero to disable the gating. Allowed values are in range 0..3000. The default value is 720 minutes.
11	Checksum for bytes 9, 10		
12..13	big-endian, int16	1	Std Initial The initial estimate for standard deviation parameter has no impact for NOx. This parameter is still in place for consistency reasons with the VOC tuning parameters command. This parameter must always be set to 50.
14	Checksum for bytes 12, 13		
15..16	big-endian, int16	1	Gain Factor Gain factor to amplify or to attenuate the NOx index output. Allowed values are in range 1..1000. The default value is 230.
17	Checksum for bytes 15, 16		

6.1.10 Read/ Write RH/T Acceleration Mode (0x60F7)

By default, the RH/T acceleration algorithm is optimized for a sensor which is positioned in free air. If the sensor is integrated into another device, the ambient RH/T output values might not be optimal due to different thermal behavior. This parameter can be used to adapt the RH/T acceleration behavior for the actual use-case, leading in an improvement of the ambient RH/T output accuracy. There is a limited set of different modes available, each identified by a number:

- 0: Low Acceleration
- 1: High Acceleration
- 2: Medium Acceleration

Medium and high accelerations are particularly indicated for air quality monitors which are subjected to large temperature changes. Low acceleration is advised for stationary devices not subject to large variations in temperature. This parameter can be changed in any state of the device, but it is applied only the next time starting a measurement, i.e., when sending a "Start Measurement" command. So, the parameter needs to be set before a new measurement is started.

Read/Write Data and Parameters:

Byte #	Datatype	Scale factor	Description
0..1	big-endian, uint16	1	RH/T acceleration mode.
2	Checksum for bytes 0, 1		

6.1.11 Read/ Write VOC Algorithm State (0x6181)

Allows to backup and restore the VOC algorithm state to resume operation after a short interruption, skipping initial learning phase. By default, the VOC algorithm resets its state to initial values each time a measurement is started, even if the measurement was stopped only for a short time. So, the VOC index output value needs a long time until it is stable again. This can be avoided by restoring the previously memorized algorithm state before starting the measure mode.

Read/Write Data and Parameters:

Byte #	Datatype	Scale factor	Description
0..1	Bytearray8	1	VOC algorithm state.
2	Checksum for bytes 0, 1		
...			
9..10	Bytearray8	1	
11	Checksum for bytes 9, 10		

6.1.12 Start Fan Cleaning (0x5607)

Starts the fan-cleaning manually. This command can only be executed in Measurement-Mode. For more details, note the explanations given in 5.2 Fan Auto Cleaning.

6.1.13 Read/Write Auto Cleaning Interval (0x8004)

Reads/Writes the interval [s] of the periodic fan-cleaning. For more details, note the explanations given in 5.2 Fan Auto Cleaning. Please note that since this configuration is volatile, it will be reverted to the default value after a device reset.

Read/Write Data and Parameters:

Byte #	Description	
0, 1	Most Significant Byte	big-endian, unsigned 32-bit integer value: Auto Cleaning Interval [s]
2	Checksum for bytes 0, 1	
3, 4	Least Significant Byte	
5	Checksum for bytes 3, 4	

6.1.14 Read Product Name (0xD014)

This command returns the product name SEN5x (SEN50, SEN54 or SEN55). It is defined as a string value with a maximum length of 32 ASCII characters (including terminating null-character).

Read/Write Data:

Byte #	Description
0	ASCII Character 0
1	ASCII Character 1
2	Checksum for bytes 0, 1
...	...
45	ASCII Character 30
46	ASCII Character 31
47	Checksum for bytes 45, 46

6.1.15 Read Serial Number (0xD033)

This command returns the requested serial number. It is defined as a string value with a maximum length of 32 ASCII characters (including terminating null-character).

Read/Write Data:

Byte #	Description
0	ASCII Character 0
1	ASCII Character 1
2	Checksum for bytes 0, 1
...	...
45	ASCII Character 30
46	ASCII Character 31
47	Checksum for bytes 45, 46

6.1.16 Read Firmware Version (0xD100)

Get firmware version.

Read/Write Data:

Byte #	Description
0	Firmware version
1	Reserved

2	Checksum for bytes 0, 1
---	-------------------------

6.1.17 Read Device Status (0xD206)

Use this command to read the Device Status Register. For more details, note the explanations given in section 5.4 Device Status Register.

Read/Write Data:

Byte #	Description	
0, 1	Most Significant Byte	big-endian, unsigned 32-bit integer value: Device Status Register
2	Checksum for bytes 0, 1	
3, 4	Least Significant Byte	
5	Checksum for bytes 3, 4	

6.1.18 Clear Device Status (0xD210)

Clears all flags in device status register.

6.1.19 Device Reset (0xD304)

Device software reset command. After calling this command, the module is in the same state as after a power reset.

7 Technical Drawings

7.1 Product outline drawings

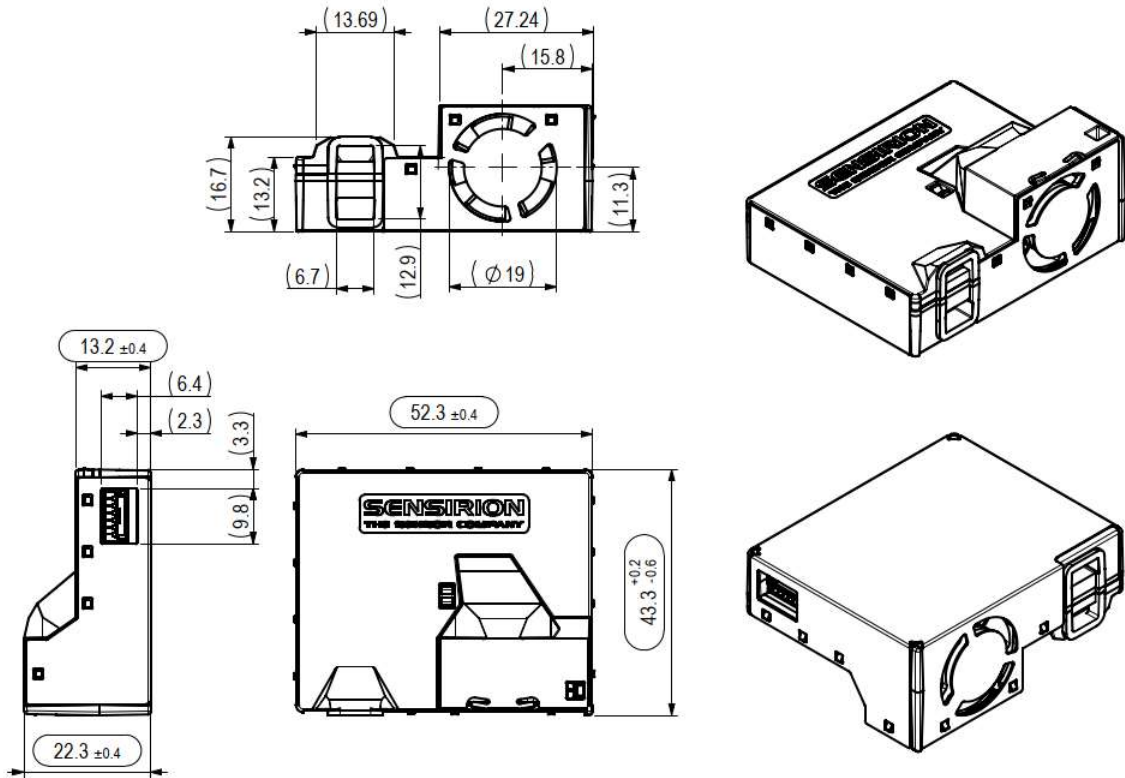

Figure 7: Package outline dimensions (given in mm) of the SEN5x.

7.2 Product Label

The SEN5x contains a label (size: 18 x 12 mm) which is attached to one side of the sensor and contains the following information:

Label Design	Label Content	Description
	SEN5x	Product name
	SDN-T	Sensirion internal marking
	XXXXXXXXXXXXXXXXXX / S	16-digit decimal serial number

Table 13 Label information.

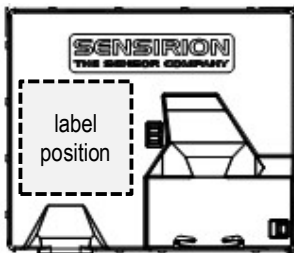

Figure 8: Indication of label position on SEN5x.

8 Revision History

Date	Version	Page(s)	Changes
January 2022	1	-	Initial version
March 2022	2	4 9-10 14 23	Updated table Added Recommended and Absolute Maximum/Minimum Operating and Storage Conditions for SEN55 and SEN50 Updated flowchart and description of operating modes Updated names for the RH/T Acceleration Mode parameters

9 Important Notices

Warning, Personal Injury

Do not use this product as safety or emergency stop devices or in any other application where failure of the product could result in personal injury. Do not use this product for applications other than its intended and authorized use. Before installing, handling, using or servicing this product, please consult the data sheet and application notes. Failure to comply with these instructions could result in death or serious injury.

If the Buyer shall purchase or use SENSIRION products for any unintended or unauthorized application, Buyer shall defend, indemnify and hold harmless SENSIRION and its officers, employees, subsidiaries, affiliates and distributors against all claims, costs, damages and expenses, and reasonable attorney fees arising out of, directly or indirectly, any claim of personal injury or death associated with such unintended or unauthorized use, even if SENSIRION shall be allegedly negligent with respect to the design or the manufacture of the product.

ESD Precautions

The inherent design of this component causes it to be sensitive to electrostatic discharge (ESD). To prevent ESD-induced damage and/or degradation, take customary and statutory ESD precautions when handling this product. See application note "ESD, Latchup and EMC" for more information.

Warranty

SENSIRION warrants solely to the original purchaser of this product for a period of 12 months (one year) from the date of delivery that this product shall be of the quality, material and workmanship defined in SENSIRION's published specifications of the product. Within such period, if proven to be defective, SENSIRION shall repair and/or replace this product, in SENSIRION's discretion, free of charge to the Buyer, provided that:

- notice in writing describing the defects shall be given to SENSIRION within fourteen (14) days after their appearance;
- such defects shall be found, to SENSIRION's reasonable satisfaction, to have arisen from SENSIRION's faulty design, material, or workmanship;
- the defective product shall be returned to SENSIRION's factory at the Buyer's expense; and
- the warranty period for any repaired or replaced product shall be limited to the unexpired portion of the original period.

This warranty does not apply to any equipment which has not been installed and used within the specifications recommended by SENSIRION for the intended and proper use of the equipment. EXCEPT FOR THE WARRANTIES EXPRESSLY SET FORTH HEREIN, SENSIRION MAKES NO WARRANTIES, EITHER EXPRESS OR IMPLIED, WITH RESPECT TO THE PRODUCT. ANY AND ALL WARRANTIES, INCLUDING WITHOUT LIMITATION, WARRANTIES OF MERCHANTABILITY OR FITNESS FOR A PARTICULAR PURPOSE, ARE EXPRESSLY EXCLUDED AND DECLINED.

SENSIRION is only liable for defects of this product arising under the conditions of operation provided for in the data sheet and proper use of the goods. SENSIRION explicitly disclaims all warranties, express or implied, for any period during which the goods are operated or stored not in accordance with the technical specifications.

SENSIRION does not assume any liability arising out of any application or use of any product or circuit and specifically disclaims any and all liability, including without limitation consequential or incidental damages. All operating parameters, including without limitation recommended parameters, must be validated for each customer's applications by customer's technical experts. Recommended parameters can and do vary in different applications.

SENSIRION reserves the right, without further notice, (i) to change the product specifications and/or the information in this document and (ii) to improve reliability, functions and design of this product.

Copyright © 2021, by SENSIRION. CMOSens® is a trademark of Sensirion. All rights reserved

Headquarters and Subsidiaries

Sensirion AG

Laubisruetistr. 50
CH-8712 Staefa ZH
Switzerland

phone: +41 44 306 40 00
fax: +41 44 306 40 30

info@sensirion.com
www.sensirion.com

Sensirion Taiwan Co. Ltd

phone: +886 3 5506701

info@sensirion.com
www.sensirion.com

Sensirion Inc., USA

phone: +1 312 690 5858

info-us@sensirion.com
www.sensirion.com

Sensirion Japan Co. Ltd.

phone: +81 3 3444 4940

info-jp@sensirion.com
www.sensirion.com/jp

Sensirion Korea Co. Ltd.

phone: +82 31 337 7700~3

info-kr@sensirion.com
www.sensirion.com/kr

Sensirion China Co. Ltd.



phone: +86 755 8252 1501

info-cn@sensirion.com
www.sensirion.com/cn

To find your local representative, please visit www.sensirion.com/distributors

Looking for pricing, stock, or lifecycle information?

Click below to explore more details on WIN SOURCE:

-  [View SEN55-SDN-T on WIN SOURCE](#)
-  [Sensirion AG Information](#)

Optimize Your Supply Chain with WIN SOURCE Solutions

-  Global Sourcing Solution
-  Obsolete Management
-  Cost Control Management
-  Shortage Management
-  Alternative Solution
-  Excess Inventory Management