



**THE DATASHEET OF
DS8922AMX/NOPB**



DS8922/DS8922A/DS8923A TRI-STATE RS-422 Dual Differential Line Driver and Receiver Pairs

Check for Samples: [DS8922](#), [DS8922A](#), [DS8923A](#)

FEATURES

- 12 ns Typical Propagation Delay
- Output Skew— ± 0.5 ns Typical
- Meets the Requirements of EIA Standard RS-422
- Complementary Driver Outputs
- High Differential or Common-Mode Input Voltage Ranges of $\pm 7V$
- $\pm 0.2V$ Receiver Sensitivity over the Input Voltage Range
- Receiver Input Fail-Safe Circuitry
- Receiver Input Hysteresis—70 mV typical
- Glitch Free Power Up/Down
- TRI-STATE Outputs

DESCRIPTION

The DS8922/22A and DS8923A are Dual Differential Line Driver and Receiver pairs. These devices are designed specifically for applications meeting the ST506, ST412 and ESDI Disk Drive Standards. In addition, the devices meet the requirements of the EIA Standard RS-422.

These devices offer an input sensitivity of 200 mV over a $\pm 7V$ common mode operating range. Hysteresis is incorporated (typically 70 mV) to improve noise margin for slowly changing input waveforms. An input fail-safe circuit is provided such that if the receiver inputs are open the output assumes the logical one state.

The DS8922A and DS8923A drivers are designed to provide unipolar differential drive to twisted pair or parallel wire transmission lines. Complementary outputs are logically ANDed and provide an output skew of 0.5 ns (typ.) with propagation delays of 12 ns.

Both devices feature TRI-STATE outputs. The DS8922/22A have independent control functions common to a driver and receiver pair. The DS8923A has separate driver and receiver control functions.

Power up/down circuitry is featured which will TRI-STATE the outputs and prevent erroneous glitches on the transmission lines during system power up or power down operation.

The DS8922/22A and DS8923A are designed to be compatible with TTL and CMOS.



Please be aware that an important notice concerning availability, standard warranty, and use in critical applications of Texas Instruments semiconductor products and disclaimers thereto appears at the end of this data sheet.

All trademarks are the property of their respective owners.



These devices have limited built-in ESD protection. The leads should be shorted together or the device placed in conductive foam during storage or handling to prevent electrostatic damage to the MOS gates.

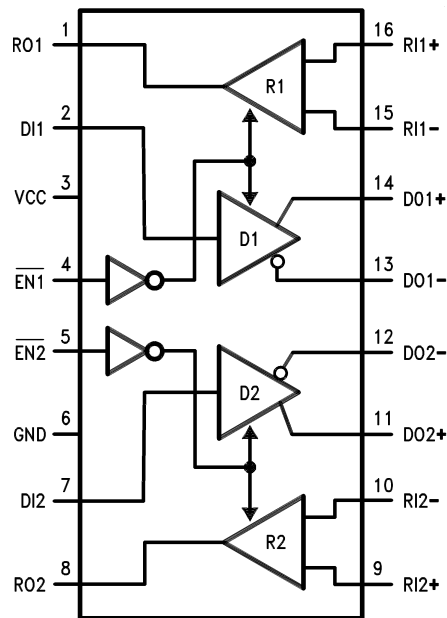

DS8922A Dual-In-Line
Top View

See Package Number D (R-PDSO-G16) or NFG0016E

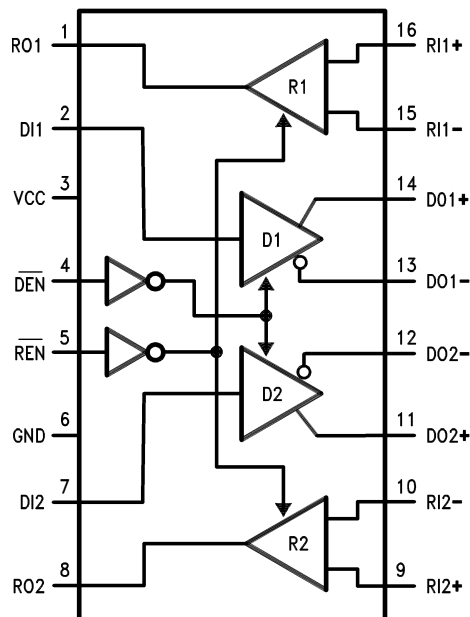

DS8923A Dual-In-Line
Top View

See Package Number D (R-PDSO-G16) or NFG0016E

DS8922/22A

$\overline{EN1}$	$\overline{EN2}$	RO1	RO2	DO1	DO2
0	0	ACTIVE	ACTIVE	ACTIVE	ACTIVE
1	0	HI-Z	ACTIVE	HI-Z	ACTIVE
0	1	ACTIVE	HI-Z	ACTIVE	HI-Z
1	1	HI-Z	HI-Z	HI-Z	HI-Z

DS8923A

\overline{DEN}	\overline{REN}	RO1	RO2	DO1	DO2
0	0	ACTIVE	ACTIVE	ACTIVE	ACTIVE
1	0	ACTIVE	ACTIVE	HI-Z	HI-Z
0	1	HI-Z	HI-Z	ACTIVE	ACTIVE
1	1	HI-Z	HI-Z	HI-Z	HI-Z

Absolute Maximum Ratings ⁽¹⁾⁽²⁾

Supply Voltage	7V
Drive Input Voltage	-0.5V to +7V
Output Voltage	5.5V
Receiver Output Sink Current	50 mA
Receiver Input Voltage	±10V
Differential Input Voltage	±12V
Maximum Package Power Dissipation @ +25°C	
D Package	1300 mW
NFG Package	1450 mW
Derate D Package 10.4 mW/°C above +25°C	
Derate NFG Package 11.6 mW/°C above +25°C	
Storage Temperature Range	-65°C to +165°C
Lead Temp. (Soldering, 4 seconds)	260°C
ESD Rating (HBM)	2000V+

- (1) "Absolute Maximum Ratings" are those values beyond which the safety of the device cannot be ensured. They are not meant to imply that the device should be operated at these limits. The Table of [Electrical Characteristics](#) provides conditions for actual device operation.
- (2) If Military/Aerospace specified devices are required, please contact the Texas Instruments Sales Office/ Distributors for availability and specifications.

Recommended Operating Conditions

	Min	Max	Units
Supply Voltage	4.5	5.5	V
Temperature (T _A)	0	70	°C

DS8922/22A and DS8923A Electrical Characteristics⁽¹⁾⁽²⁾⁽³⁾

Symbol	Conditions	Min	Typ	Max	Units
RECEIVER					
V_{TH}	$-7V \leq V_{CM} \leq +7V$	-200	±35	+200	mV
V_{HYST}	$-7V \leq V_{CM} \leq +7V$	15	70		mV
R_{IN}	$V_{IN} = -7V, +7V$ (Other Input = GND)	4.0	6.0		kΩ
I_{IN}	$V_{IN} = 10V$			3.25	mA
	$V_{IN} = -10V$			-3.25	mA
V_{OH}	$V_{CC} = MIN, I_{OH} = -400 \mu A$	2.5			V
V_{OL}	$V_{CC} = MAX, I_{OL} = 8 mA$			0.5	V
I_{SC}	$V_{CC} = MAX, V_{OUT} = 0V$	-15		-100	mA
DRIVER					
V_{OH}	$V_{CC} = MIN, I_{OH} = -20 mA$	2.5			V
V_{OL}	$V_{CC} = MIN, I_{OL} = +20 mA$			0.5	V
I_{OFF}	$V_{CC} = 0V, V_{OUT} = 5.5V$			100	μA
$ VT - \overline{VT} $				0.4	V
VT		2.0			V
$ V_{OS} - \overline{V_{OS}} $				0.4	V
I_{SC}	$V_{CC} = MAX, V_{OUT} = 0V$	-30		-150	mA
DRIVER and RECEIVER					
I_{OZ}				50	μA
TRI-STATE	$V_{CC} = MAX$			-50	μA
Leakage					
I_{CC}	$V_{CC} = MAX$			76	mA
				78	mA
DRIVER and ENABLE INPUTS					
V_{IH}		2.0			V
V_{IL}				0.8	V
I_{IL}	$V_{CC} = MAX, V_{IN} = 0.4V$		-40	-200	μA
I_{IH}	$V_{CC} = MAX, V_{IN} = 2.7V$			20	μA
I_I	$V_{CC} = MAX, V_{IN} = 7.0V$			100	μA
V_{CL}	$V_{CC} = MIN, I_{IN} = -18 mA$			-1.5	V

(1) All currents into device pins are shown as positive values; all currents out of the device are shown as negative; all voltages are referenced to ground unless otherwise specified. All values shown as max or min are classified on absolute value basis.

(2) All typical values are $V_{CC} = 5V, T_A = 25^\circ C$.

(3) Only one output at a time should be shorted.

Receiver Switching Characteristics (Figure 1) (Figure 2) (Figure 2)

Parameter	Conditions	Min	Typ	Max		Units
				8922	8922A/23A	
T_{pLH}	CL = 30 pF		12	22.5	20	ns
T_{pHL}	CL = 30 pF		12	22.5	20	ns
$ T_{pLH} - T_{pHL} $	CL = 30 pF		0.5	5	3.5	ns
Skew (Channel to Channel)	CL = 30 pF		0.5	3.0	2.0	ns
T_{pLZ}	CL = 15 pF S2 Open		15			ns
T_{pHZ}	CL = 15 pF S1 Open		15			ns
T_{pZL}	CL = 30 pF S2 Open		20			ns
T_{pZH}	CL = 30 pF S1 Open		20			ns

Driver Switching Characteristics

Parameter	Conditions	Min	Typ	Max		Units
				8922	8922A/23A	
SINGLE ENDED CHARACTERISTICS (Figure 4, Figure 5, Figure 6, and Figure 8)						
T_{pLH}	CL = 30 pF		12	15	15	ns
T_{pHL}	CL = 30 pF		12	15	15	ns
T_{TLH}	CL = 30 pF		5	10	10	ns
T_{THL}	CL = 30 pF		5	10	10	ns
$ T_{pLH} - T_{pHL} $	CL = 30 pF		0.5			ns
Skew	CL = 30 pF ⁽¹⁾		0.5	5	3.5	ns
Skew (Channel to Channel)			0.5	3.0	2.0	ns
T_{pLZ}	CL = 30 pF		15			ns
T_{pHZ}	CL = 30 pF		15			ns
T_{pZL}	CL = 30 pF		20			ns
T_{pZH}	CL = 30 pF		20			ns
DIFFERENTIAL SWITCHING CHARACTERISTICS ⁽²⁾ , (Figure 4)						
T_{pLH}	CL = 30 pF		12	15	15	ns
T_{pHL}	CL = 30 pF		12	15	15	ns
$ T_{pLH} - T_{pHL} $	CL = 30 pF		0.5	6.0	2.75	ns

- (1) Difference between complementary outputs at the 50% point.
 (2) Differential Delays are defined as calculated results from single ended rise and fall time measurements. This approach in establishing AC performance specifications has been taken due to limitations of available Automatic Test Equipment (ATE). The calculated ATE results assume a linear transition between measurement points and are a result of the following equations:

$$T_{cp} = \frac{(T_{fb} \times T_{rb}) - (T_{ra} \times T_{fa})}{T_{rb} - T_{ra} - T_{fa} + T_{fb}}$$
 Where: T_{cp} = Crossing Point T_{ra} , T_{rb} , T_{fa} and T_{fb} are time measurements with respect to the input.

Switching Time Waveforms

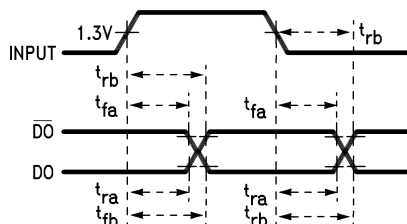

AC Test Circuits and Switching Waveforms

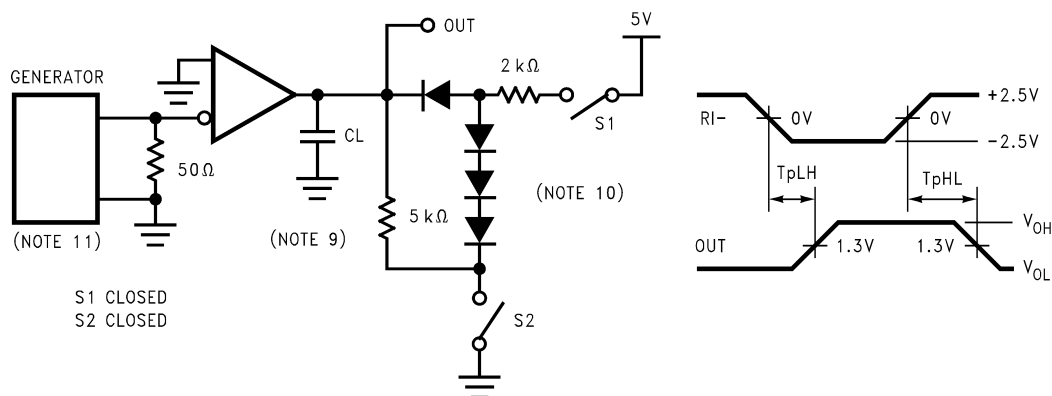

Figure 1.

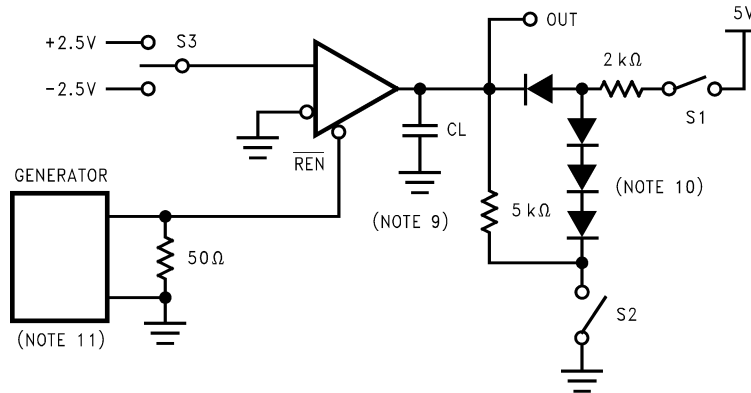

Figure 2.

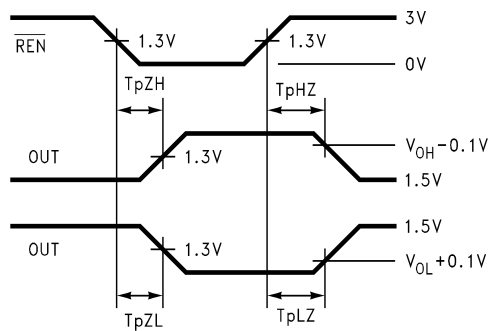
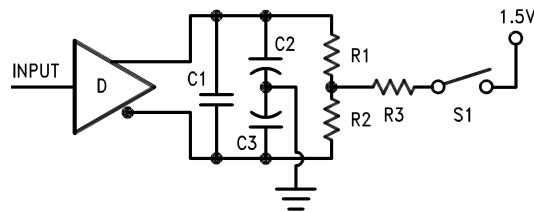

Figure 3.

	S1	S2	S3
T _{PLZ}	Closed	Open	+2.5V
T _{PHZ}	Open	Closed	-2.5V
T _{PZL}	Closed	Open	+2.5V
T _{PZH}	Open	Closed	-2.5V



NOTE: C1=C2=C3=30 pF, R1=R2=50 Ω, R3=500 Ω

Figure 4.

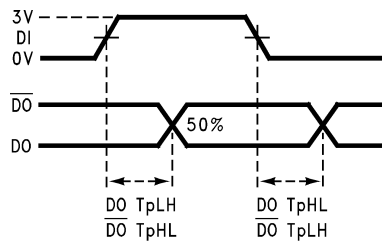

Figure 5.

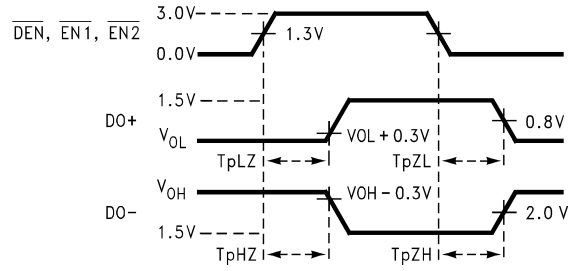

Figure 6.

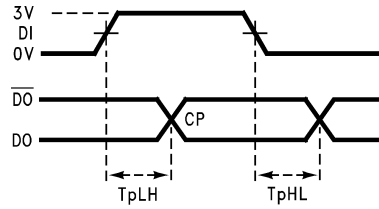

Figure 7.

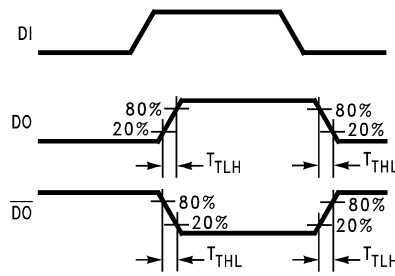

Figure 8.

Typical Performance Characteristics
(DS8923A)

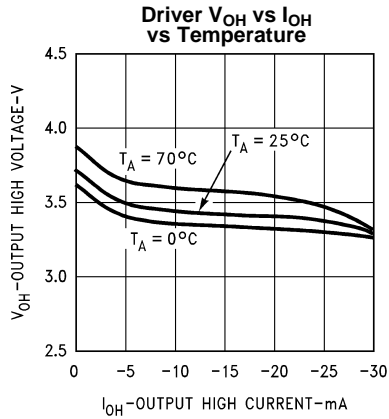

Figure 9.

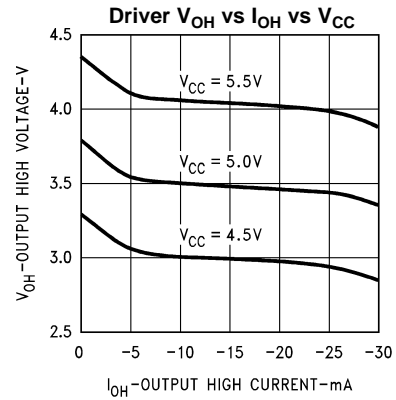

Figure 10.

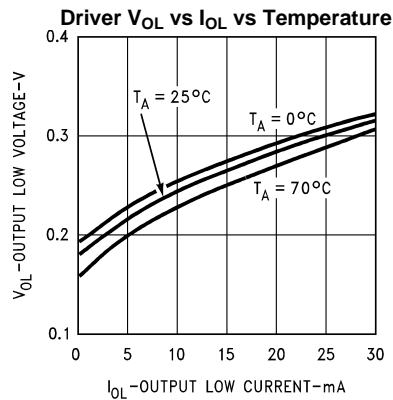

Figure 11.

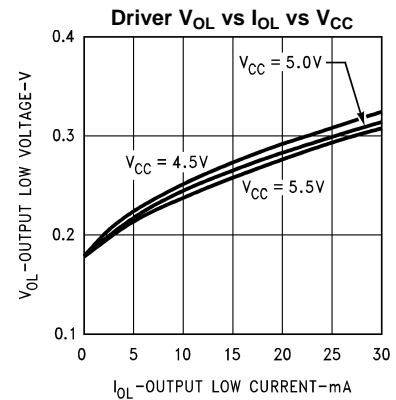

Figure 12.

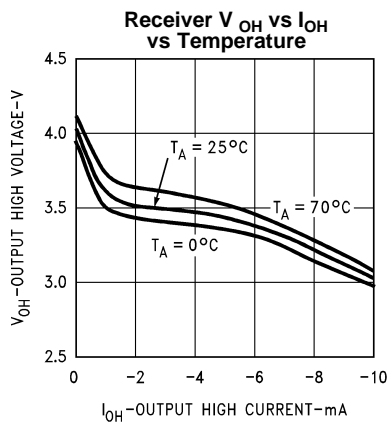

Figure 13.

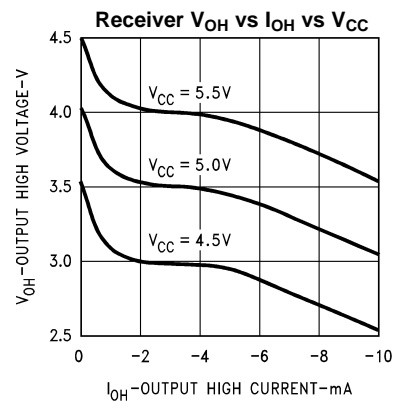

Figure 14.

Typical Performance Characteristics (continued)

(DS8923A)

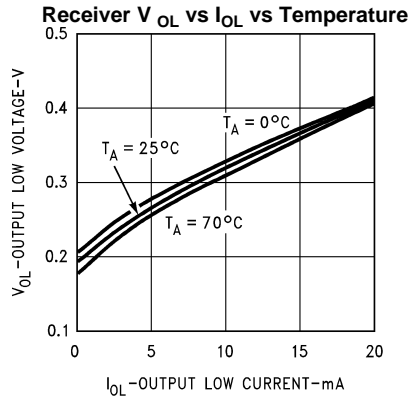

Figure 15.

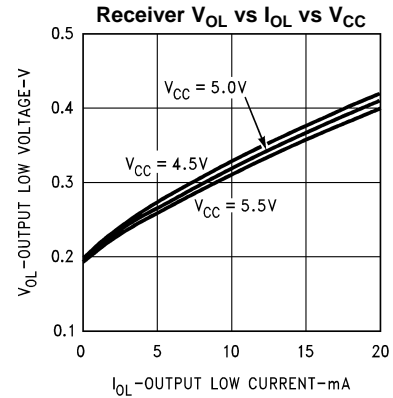

Figure 16.

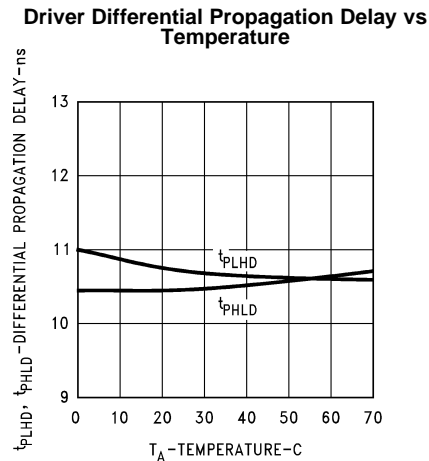

Figure 17.

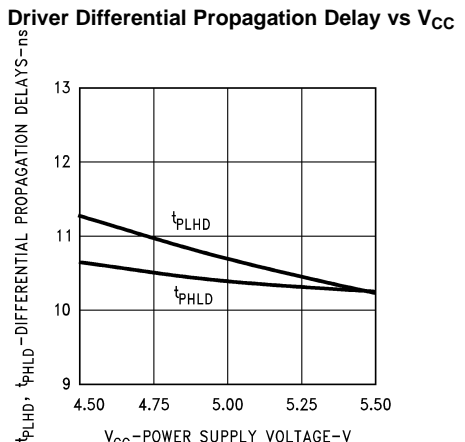

Figure 18.

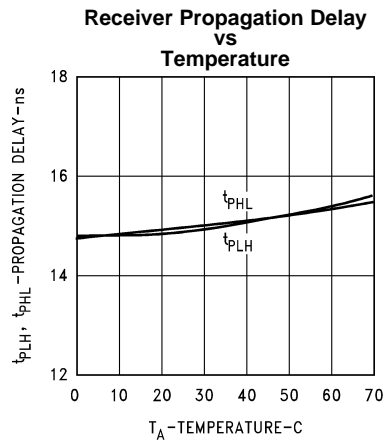

Figure 19.

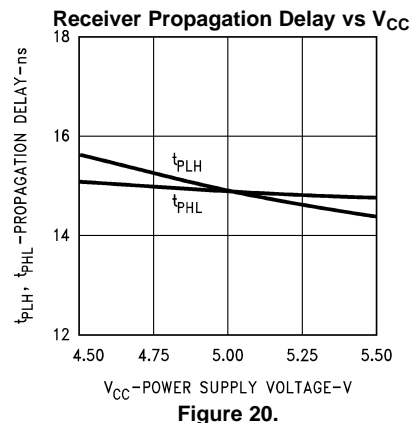

Figure 20.

Typical Performance Characteristics (continued)

(DS8923A)

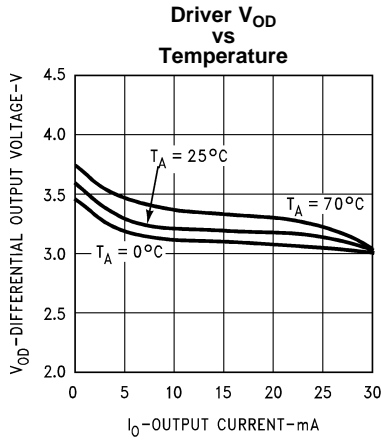

Figure 21.

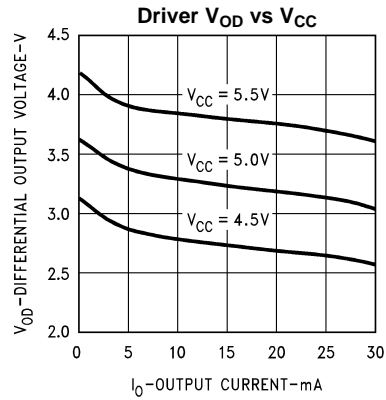

Figure 22.

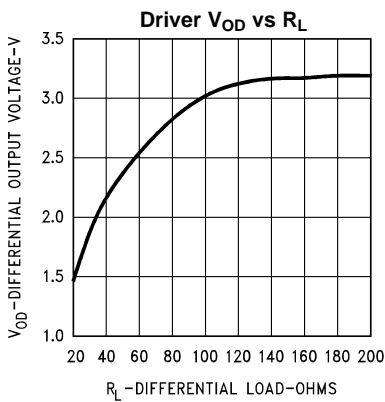

Figure 23.

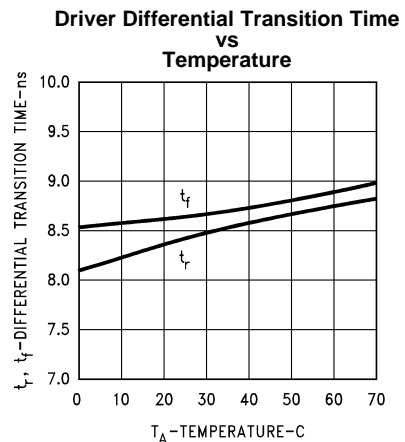

Figure 24.

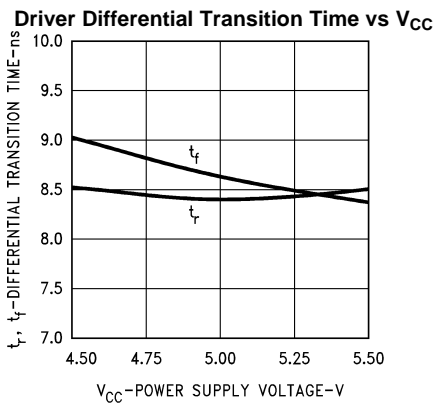

Figure 25.

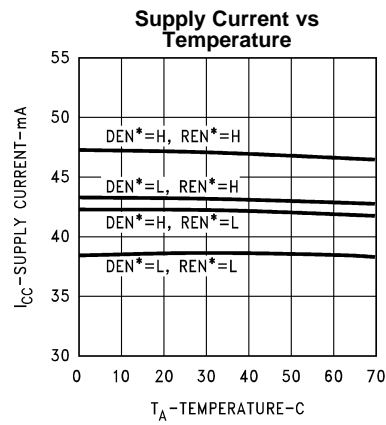

Figure 26.

Typical Performance Characteristics (continued)

(DS8923A)

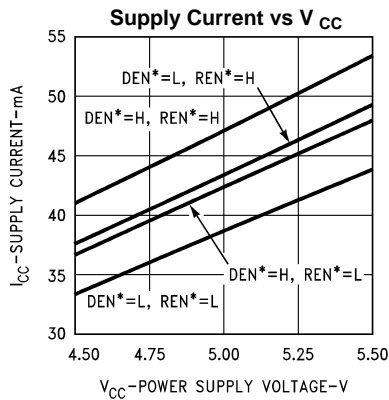

Figure 27.

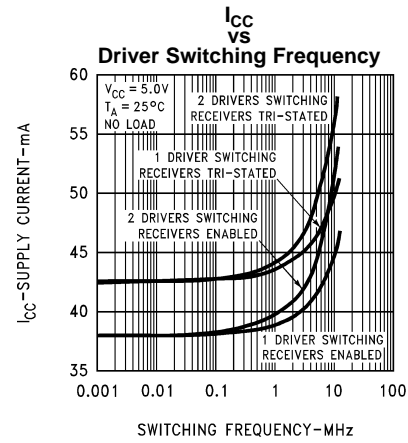

Figure 28.

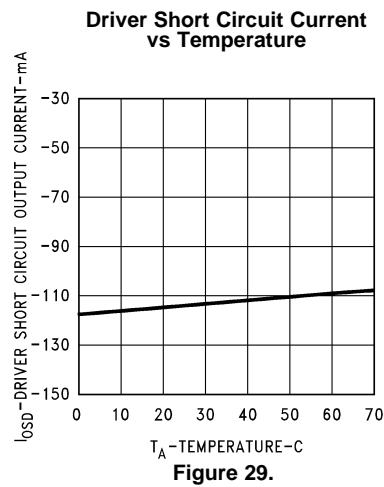

Figure 29.

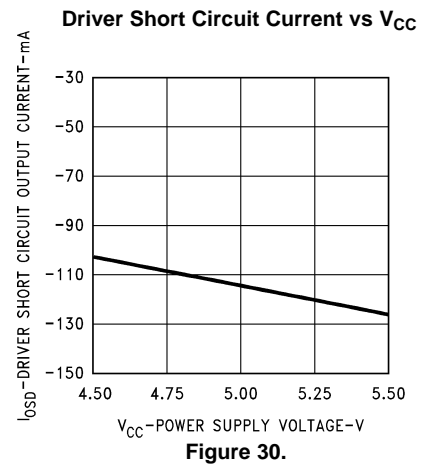

Figure 30.

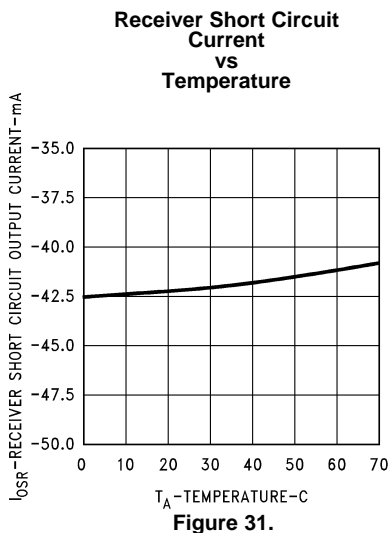

Figure 31.

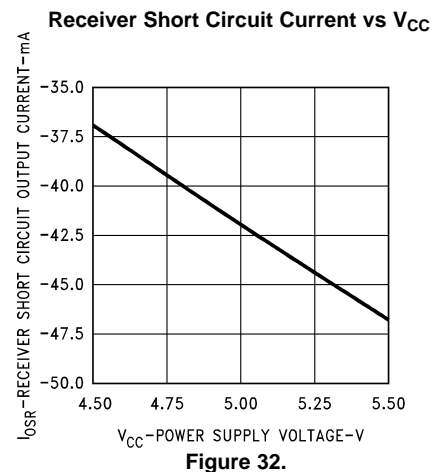

Figure 32.

TYPICAL APPLICATIONS

Figure 33. ESDI Application

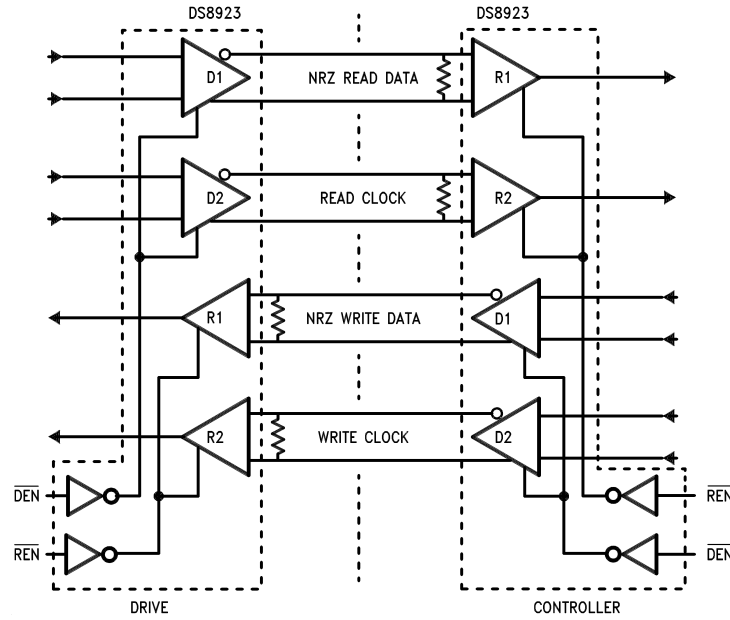

Figure 34.

Figure 35. ST504 and ST412 Applications

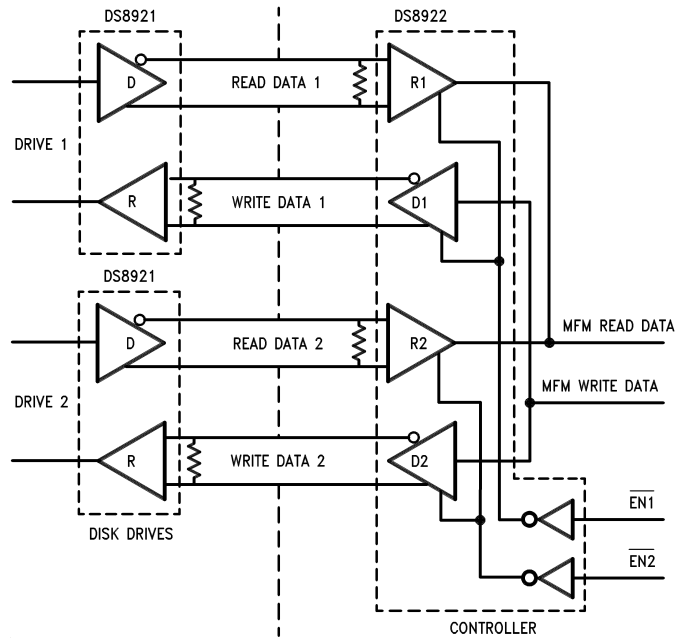

Figure 36.

REVISION HISTORY

Changes from Revision A (April 2013) to Revision B	Page
<hr/> <ul style="list-style-type: none">• Changed layout of National Data Sheet to TI format	<hr/> 12

PACKAGING INFORMATION

Orderable Device	Status (1)	Package Type	Package Drawing	Pins	Package Qty	Eco Plan (2)	Lead/Ball Finish (6)	MSL Peak Temp (3)	Op Temp (°C)	Device Marking (4/5)	Samples
DS8922AM/NOPB	LIFEBUY	SOIC	D	16	48	Green (RoHS & no Sb/Br)	CU SN	Level-1-260C-UNLIM	0 to 70	DS8922AM	
DS8922AMX/NOPB	LIFEBUY	SOIC	D	16	2500	Green (RoHS & no Sb/Br)	CU SN	Level-1-260C-UNLIM	0 to 70	DS8922AM	
DS8923AM/NOPB	LIFEBUY	SOIC	D	16	48	Green (RoHS & no Sb/Br)	CU SN	Level-1-260C-UNLIM	0 to 70	DS8923AM	
DS8923AN/NOPB	LIFEBUY	PDIP	NFG	16	25	Pb-Free (RoHS)	CU SN	Level-1-NA-UNLIM	0 to 70	DS8923AN	

(1) The marketing status values are defined as follows:

ACTIVE: Product device recommended for new designs.

LIFEBUY: TI has announced that the device will be discontinued, and a lifetime-buy period is in effect.

NRND: Not recommended for new designs. Device is in production to support existing customers, but TI does not recommend using this part in a new design.

PREVIEW: Device has been announced but is not in production. Samples may or may not be available.

OBSELETE: TI has discontinued the production of the device.

(2) **RoHS:** TI defines "RoHS" to mean semiconductor products that are compliant with the current EU RoHS requirements for all 10 RoHS substances, including the requirement that RoHS substance do not exceed 0.1% by weight in homogeneous materials. Where designed to be soldered at high temperatures, "RoHS" products are suitable for use in specified lead-free processes. TI may reference these types of products as "Pb-Free".

RoHS Exempt: TI defines "RoHS Exempt" to mean products that contain lead but are compliant with EU RoHS pursuant to a specific EU RoHS exemption.

Green: TI defines "Green" to mean the content of Chlorine (Cl) and Bromine (Br) based flame retardants meet JS709B low halogen requirements of <=1000ppm threshold. Antimony trioxide based flame retardants must also meet the <=1000ppm threshold requirement.

(3) MSL, Peak Temp. - The Moisture Sensitivity Level rating according to the JEDEC industry standard classifications, and peak solder temperature.

(4) There may be additional marking, which relates to the logo, the lot trace code information, or the environmental category on the device.

(5) Multiple Device Markings will be inside parentheses. Only one Device Marking contained in parentheses and separated by a "-" will appear on a device. If a line is indented then it is a continuation of the previous line and the two combined represent the entire Device Marking for that device.

(6) Lead/Ball Finish - Orderable Devices may have multiple material finish options. Finish options are separated by a vertical ruled line. Lead/Ball Finish values may wrap to two lines if the finish value exceeds the maximum column width.

Important Information and Disclaimer:The information provided on this page represents TI's knowledge and belief as of the date that it is provided. TI bases its knowledge and belief on information provided by third parties, and makes no representation or warranty as to the accuracy of such information. Efforts are underway to better integrate information from third parties. TI has taken and

continues to take reasonable steps to provide representative and accurate information but may not have conducted destructive testing or chemical analysis on incoming materials and chemicals. TI and TI suppliers consider certain information to be proprietary, and thus CAS numbers and other limited information may not be available for release.

In no event shall TI's liability arising out of such information exceed the total purchase price of the TI part(s) at issue in this document sold by TI to Customer on an annual basis.

N0016E

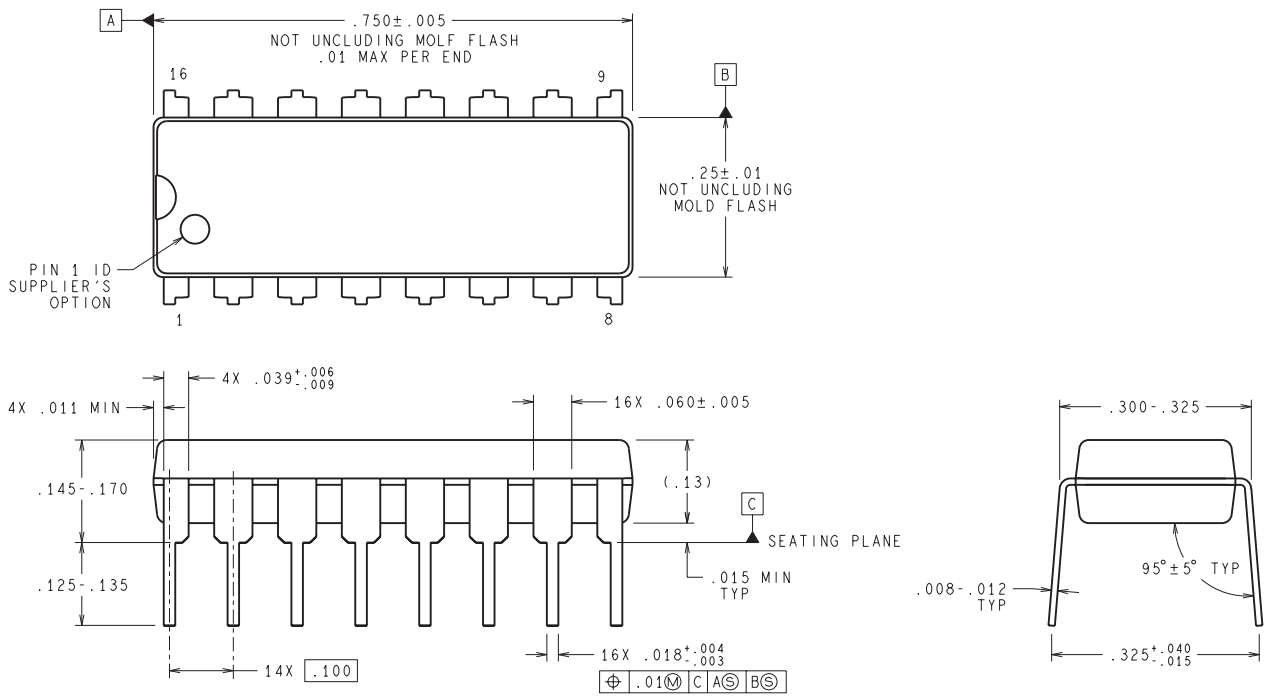

DIMENSIONS ARE IN INCHES
 DIMENSIONS IN () FOR REFERENCE ONLY



N16E (Rev G)

D (R-PDSO-G16)

PLASTIC SMALL OUTLINE



4040047-6/M 06/11

- NOTES:
- A. All linear dimensions are in inches (millimeters).
 - B. This drawing is subject to change without notice.
 -  C. Body length does not include mold flash, protrusions, or gate burrs. Mold flash, protrusions, or gate burrs shall not exceed 0.006 (0,15) each side.
 -  D. Body width does not include interlead flash. Interlead flash shall not exceed 0.017 (0,43) each side.
 - E. Reference JEDEC MS-012 variation AC.

IMPORTANT NOTICE

Texas Instruments Incorporated (TI) reserves the right to make corrections, enhancements, improvements and other changes to its semiconductor products and services per JESD46, latest issue, and to discontinue any product or service per JESD48, latest issue. Buyers should obtain the latest relevant information before placing orders and should verify that such information is current and complete.

TI's published terms of sale for semiconductor products (<http://www.ti.com/sc/docs/stdterms.htm>) apply to the sale of packaged integrated circuit products that TI has qualified and released to market. Additional terms may apply to the use or sale of other types of TI products and services.

Reproduction of significant portions of TI information in TI data sheets is permissible only if reproduction is without alteration and is accompanied by all associated warranties, conditions, limitations, and notices. TI is not responsible or liable for such reproduced documentation. Information of third parties may be subject to additional restrictions. Resale of TI products or services with statements different from or beyond the parameters stated by TI for that product or service voids all express and any implied warranties for the associated TI product or service and is an unfair and deceptive business practice. TI is not responsible or liable for any such statements.

Buyers and others who are developing systems that incorporate TI products (collectively, "Designers") understand and agree that Designers remain responsible for using their independent analysis, evaluation and judgment in designing their applications and that Designers have full and exclusive responsibility to assure the safety of Designers' applications and compliance of their applications (and of all TI products used in or for Designers' applications) with all applicable regulations, laws and other applicable requirements. Designer represents that, with respect to their applications, Designer has all the necessary expertise to create and implement safeguards that (1) anticipate dangerous consequences of failures, (2) monitor failures and their consequences, and (3) lessen the likelihood of failures that might cause harm and take appropriate actions. Designer agrees that prior to using or distributing any applications that include TI products, Designer will thoroughly test such applications and the functionality of such TI products as used in such applications.

TI's provision of technical, application or other design advice, quality characterization, reliability data or other services or information, including, but not limited to, reference designs and materials relating to evaluation modules, (collectively, "TI Resources") are intended to assist designers who are developing applications that incorporate TI products; by downloading, accessing or using TI Resources in any way, Designer (individually or, if Designer is acting on behalf of a company, Designer's company) agrees to use any particular TI Resource solely for this purpose and subject to the terms of this Notice.

TI's provision of TI Resources does not expand or otherwise alter TI's applicable published warranties or warranty disclaimers for TI products, and no additional obligations or liabilities arise from TI providing such TI Resources. TI reserves the right to make corrections, enhancements, improvements and other changes to its TI Resources. TI has not conducted any testing other than that specifically described in the published documentation for a particular TI Resource.

Designer is authorized to use, copy and modify any individual TI Resource only in connection with the development of applications that include the TI product(s) identified in such TI Resource. NO OTHER LICENSE, EXPRESS OR IMPLIED, BY ESTOPPEL OR OTHERWISE TO ANY OTHER TI INTELLECTUAL PROPERTY RIGHT, AND NO LICENSE TO ANY TECHNOLOGY OR INTELLECTUAL PROPERTY RIGHT OF TI OR ANY THIRD PARTY IS GRANTED HEREIN, including but not limited to any patent right, copyright, mask work right, or other intellectual property right relating to any combination, machine, or process in which TI products or services are used. Information regarding or referencing third-party products or services does not constitute a license to use such products or services, or a warranty or endorsement thereof. Use of TI Resources may require a license from a third party under the patents or other intellectual property of the third party, or a license from TI under the patents or other intellectual property of TI.

TI RESOURCES ARE PROVIDED "AS IS" AND WITH ALL FAULTS. TI DISCLAIMS ALL OTHER WARRANTIES OR REPRESENTATIONS, EXPRESS OR IMPLIED, REGARDING RESOURCES OR USE THEREOF, INCLUDING BUT NOT LIMITED TO ACCURACY OR COMPLETENESS, TITLE, ANY EPIDEMIC FAILURE WARRANTY AND ANY IMPLIED WARRANTIES OF MERCHANTABILITY, FITNESS FOR A PARTICULAR PURPOSE, AND NON-INFRINGEMENT OF ANY THIRD PARTY INTELLECTUAL PROPERTY RIGHTS. TI SHALL NOT BE LIABLE FOR AND SHALL NOT DEFEND OR INDEMNIFY DESIGNER AGAINST ANY CLAIM, INCLUDING BUT NOT LIMITED TO ANY INFRINGEMENT CLAIM THAT RELATES TO OR IS BASED ON ANY COMBINATION OF PRODUCTS EVEN IF DESCRIBED IN TI RESOURCES OR OTHERWISE. IN NO EVENT SHALL TI BE LIABLE FOR ANY ACTUAL, DIRECT, SPECIAL, COLLATERAL, INDIRECT, PUNITIVE, INCIDENTAL, CONSEQUENTIAL OR EXEMPLARY DAMAGES IN CONNECTION WITH OR ARISING OUT OF TI RESOURCES OR USE THEREOF, AND REGARDLESS OF WHETHER TI HAS BEEN ADVISED OF THE POSSIBILITY OF SUCH DAMAGES.

Unless TI has explicitly designated an individual product as meeting the requirements of a particular industry standard (e.g., ISO/TS 16949 and ISO 26262), TI is not responsible for any failure to meet such industry standard requirements.

Where TI specifically promotes products as facilitating functional safety or as compliant with industry functional safety standards, such products are intended to help enable customers to design and create their own applications that meet applicable functional safety standards and requirements. Using products in an application does not by itself establish any safety features in the application. Designers must ensure compliance with safety-related requirements and standards applicable to their applications. Designer may not use any TI products in life-critical medical equipment unless authorized officers of the parties have executed a special contract specifically governing such use. Life-critical medical equipment is medical equipment where failure of such equipment would cause serious bodily injury or death (e.g., life support, pacemakers, defibrillators, heart pumps, neurostimulators, and implantables). Such equipment includes, without limitation, all medical devices identified by the U.S. Food and Drug Administration as Class III devices and equivalent classifications outside the U.S.

TI may expressly designate certain products as completing a particular qualification (e.g., Q100, Military Grade, or Enhanced Product). Designers agree that it has the necessary expertise to select the product with the appropriate qualification designation for their applications and that proper product selection is at Designers' own risk. Designers are solely responsible for compliance with all legal and regulatory requirements in connection with such selection.

Designer will fully indemnify TI and its representatives against any damages, costs, losses, and/or liabilities arising out of Designer's non-compliance with the terms and provisions of this Notice.

Looking for pricing, stock, or lifecycle information?

Click below to explore more details on WIN SOURCE:

 [View DS8922AMX/NOPB on WIN SOURCE](#)

 [Texas Instruments](#) Information

Optimize Your Supply Chain with WIN SOURCE Solutions

-  Global Sourcing Solution
-  Obsolete Management
-  Cost Control Management
-  Shortage Management
-  Alternative Solution
-  Excess Inventory Management