



**THE DATASHEET OF  
DS8921ATM/NOPB**



## DS8921x Differential Line Driver and Receiver Pair

### 1 Features

- 12-ns Typical Propagation Delay
- Output Skew: 0.5 ns Typical
- Meets the Requirements of EIA Standard RS-422
- Complementary Driver Outputs
- High Differential or Common-Mode Input Voltage Ranges of  $\pm 7$  V
- $\pm 0.2$  V Receiver Sensitivity Over the Input Voltage Range
- Receiver Input Hysteresis: 70 mV Typical
- DS8921AT Industrial Temperature Operation: ( $-40^{\circ}\text{C}$  to  $+85^{\circ}\text{C}$ )

### 2 Applications

- Differential Line Driver and Receiver for:
  - ST506 Disk Drive Standard
  - ST412 Disk Drive Standard
  - ESDI Disk Drive Standard
  - RS-422 Interface

### 3 Description

The DS8921, DS8921A, and DS8921AT devices are differential line driver and receiver pairs designed specifically for applications meeting the ST506, ST412, and ESDI disk drive standards. In addition, these devices meet the requirements of the EIA standard RS-422.

The DS8921x receivers offer an input sensitivity of 200 mV over a  $\pm 7$  V common mode operating range. Hysteresis is incorporated (typically 70 mV) to improve noise margin for slowly changing input waveforms.

The DS8921x drivers are designed to provide unipolar differential drive to twisted-pair or parallel wire transmission lines. Complementary outputs are logically ANDed and provide an output skew of 0.5 ns (typical) with propagation delays of 12 ns.

The DS8921x devices are designed to be compatible with TTL and CMOS.

#### Device Information<sup>(1)</sup>

PART NUMBER	PACKAGE	BODY SIZE (NOM)
DS8921	SOIC (8)	4.90 mm x 3.91 mm
DS8921A	PDIP (8)	9.81 mm x 6.35 mm
DS8921AT		

(1) For all available packages, see the orderable addendum at the end of the data sheet.

#### Typical Application Block Diagram

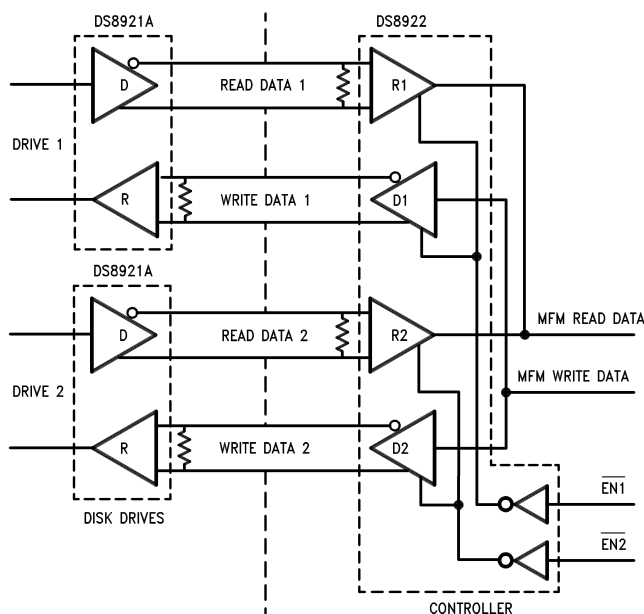

#### Simplified Functional Block Diagram

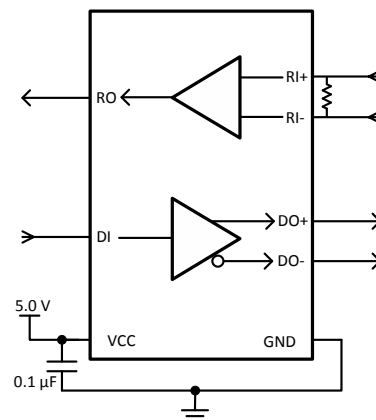

## Table of Contents

<b>1 Features</b> ..... 1 <b>2 Applications</b> ..... 1 <b>3 Description</b> ..... 1 <b>4 Revision History</b> ..... 2 <b>5 Pin Configuration and Functions</b> ..... 3 <b>6 Specifications</b> ..... 3 6.1 Absolute Maximum Ratings ..... 3 6.2 ESD Ratings..... 4 6.3 Recommended Operating Conditions..... 4 6.4 Electrical Characteristics..... 4 6.5 Receiver Switching Characteristics ..... 5 6.6 Driver Switching Characteristics: Single-Ended Characteristics ..... 5 6.7 Driver Switching Characteristics: Differential Characteristics ..... 5 6.8 Typical Characteristics ..... 6 <b>7 Parameter Measurement Information</b> ..... 6 7.1 AC Test Circuits and Switching Diagrams ..... 6 <b>8 Detailed Description</b> ..... 8	8.1 Overview ..... 8 8.2 Functional Block Diagram ..... 8 8.3 Feature Description..... 8 8.4 Device Functional Modes..... 8 <b>9 Application and Implementation</b> ..... 9 9.1 Application Information..... 9 9.2 Typical Application ..... 9 <b>10 Power Supply Recommendations</b> ..... 12 <b>11 Layout</b> ..... 12 11.1 Layout Guidelines ..... 12 11.2 Layout Example ..... 12 <b>12 Device and Documentation Support</b> ..... 13 12.1 Related Links ..... 13 12.2 Trademarks ..... 13 12.3 Electrostatic Discharge Caution..... 13 12.4 Glossary ..... 13 <b>13 Mechanical, Packaging, and Orderable Information</b> ..... 13
---	--

## 4 Revision History

NOTE: Page numbers for previous revisions may differ from page numbers in the current version.

<b>Changes from Revision C (April 2013) to Revision D</b>	<b>Page</b>
<ul style="list-style-type: none"> <li>• Added <i>ESD Ratings</i> table, <i>Feature Description</i> section, <i>Device Functional Modes</i>, <i>Application and Implementation</i> section, <i>Power Supply Recommendations</i> section, <i>Layout</i> section, <i>Device and Documentation Support</i> section, and <i>Mechanical, Packaging, and Orderable Information</i> section ..... 1</li> </ul>	1

<b>Changes from Revision B (November 2004) to Revision C</b>	<b>Page</b>
<ul style="list-style-type: none"> <li>• Changed layout of National Data Sheet to TI format. .... 1</li> </ul>	1

## 5 Pin Configuration and Functions

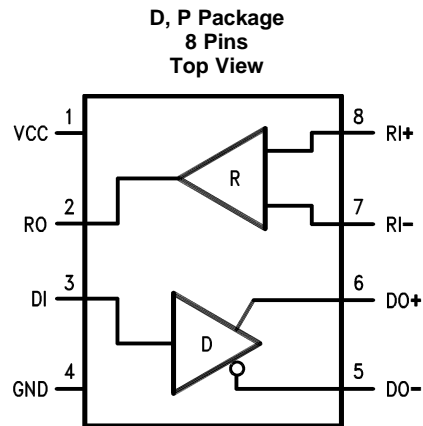

**Pin Functions**

PIN		I/O	DESCRIPTION
NAME	NO.		
<b>DIFFERENTIAL SIGNALING I/O</b>			
DI	3	I	TTL/CMOS Compatible Driver Input
DO+, DO-	6, 5	O	Inverting and non-inverting differential driver outputs
RI+, RI-	8, 7	I	Inverting and non-inverting differential receiver inputs
RO	2	O	Receiver Output Pin
<b>POWER</b>			
GND	4	Power	Ground Pin
VCC	1	Power	Supply pin, provide 5-V supply

## 6 Specifications

### 6.1 Absolute Maximum Ratings<sup>(1)(2)</sup>

	MIN	MAX	UNIT
Supply Voltage		7	V
Driver Input Voltage	-0.5	7	V
Output Voltage		5.5	V
Receiver Output Sink Current		50	mA
Receiver Input Voltage	-10	10	V
Differential Input Voltage	-12	12	V
Maximum Package Power Dissipation at 25°C: D Package		730	mW
Maximum Package Power Dissipation at 25°C: P Package		1160	mW
Derate D Package, above 25°C		9.3	mW/°C
Derate P Package, above 25°C		5.8	mW/°C
Lead Temperature		260	°C
(Soldering, 4 sec.)		260	°C
Maximum Junction Temperature		150	°C
Storage Temperature, T <sub>stg</sub>	-65	165	°C

- (1) Stresses beyond those listed under *Absolute Maximum Ratings* may cause permanent damage to the device. These are stress ratings only, which do not imply functional operation of the device at these or any other conditions beyond those indicated under *Recommended Operating Conditions*. Exposure to absolute-maximum-rated conditions for extended periods may affect device reliability.
- (2) If Military/Aerospace specified devices are required, please contact the Texas Instrument Sales Office/ Distributors for availability and specifications.

## 6.2 ESD Ratings

		VALUE	UNIT
$V_{(ESD)}$ Electrostatic discharge	Human-body model (HBM), per ANSI/ESDA/JEDEC JS-001 <sup>(1)</sup>	±2000	V
	Charged-device model (CDM), per JEDEC specification JESD22-C101 <sup>(2)</sup>	±1500	

(1) JEDEC document JEP155 states that 500-V HBM allows safe manufacturing with a standard ESD control process.

(2) JEDEC document JEP157 states that 250-V CDM allows safe manufacturing with a standard ESD control process.

## 6.3 Recommended Operating Conditions

	MIN	MAX	UNIT
Supply Voltage	4.5	5.5	V
Temperature ( $T_A$ ): DS8921/DS8921A	0	70	°C
Temperature ( $T_A$ ): DS8921AT	-40	85	°C

## 6.4 Electrical Characteristics

Over operating free-air temperature range unless otherwise noted.<sup>(1)(2)(3)</sup>

TEST CONDITIONS		MIN	TYP	MAX	UNIT
<b>RECEIVER</b>					
$V_{TH}$	$-7\text{ V} \leq V_{CM} \leq +7\text{ V}$	-200	±35	+200	mV
$V_{HYST}$	$-7\text{ V} \leq V_{CM} \leq +7\text{ V}$	15	70		mV
$R_{IN}$	$V_{IN} = -7\text{ V}, +7\text{ V}, (\text{Other Input} = \text{GND})$	4.0	6.0		kΩ
$I_{IN}$	$V_{IN} = 10\text{ V}$			3.25	mA
	$V_{IN} = -10\text{ V}$			-3.25	mA
$V_{OH}$	$I_{OH} = -400\text{ }\mu\text{A}$	2.5			V
$V_{OL}$	$I_{OL} = 8\text{ mA}$			0.5	V
$I_{SC}$	$V_{CC} = \text{MAX}, V_{OUT} = 0\text{ V}$	-15		-100	mA
<b>DRIVER</b>					
$V_{IH}$		2.0			V
$V_{IL}$				0.8	V
$I_{IL}$	$V_{CC} = \text{MAX}, V_{IN} = 0.4\text{ V}$		-40	-200	μA
$I_{IH}$	$V_{CC} = \text{MAX}, V_{IN} = 2.7\text{ V}$			20	μA
$I_I$	$V_{CC} = \text{MAX}, V_{IN} = 7.0\text{ V}$			100	μA
$V_{CL}$	$V_{CC} = \text{MIN}, I_{IN} = -18\text{ mA}$			-1.5	V
$V_{OH}$	$V_{CC} = \text{MIN}, I_{OH} = -20\text{ mA}$	2.5			V
$V_{OL}$	$V_{CC} = \text{MIN}, I_{OL} = +20\text{ mA}$			0.5	V
$I_{OFF}$	$V_{CC} = 0\text{ V}, V_{OUT} = 5.5\text{ V}$			100	μA
$ V_T  -  \overline{V_T} $				0.4	V
$V_T$		2.0			V
$ V_{OS} - \overline{V_{OS}} $				0.4	V
$I_{SC}$	$V_{CC} = \text{MAX}, V_{OUT} = 0\text{ V}$	-30		-150	mA
<b>DRIVER AND RECEIVER</b>					
$I_{CC}$	$V_{CC} = \text{MAX}, V_{OUT} = \text{Logic } 0$			35	mA

(1) All currents into device pins are shown as positive values; all currents out of the device are shown as negative; all voltages are referenced to ground unless otherwise specified. All values shown as max or min are classified on absolute value basis.

(2) All typical values are  $V_{CC} = 5\text{ V}, T_A = 25^\circ\text{C}$ .

(3) Only one output at a time should be shorted.

## 6.5 Receiver Switching Characteristics

TEST CONDITIONS		MIN	TYP	MAX 8921	MAX 8921A	MAX 8921AT	UNIT
$t_{pLH}$	$C_L = 30$ pF (Figure 3 and Figure 4)		14	22.5	20	20	ns
$t_{pHL}$	$C_L = 30$ pF (Figure 3 and Figure 4)		14	22.5	20	20	ns
$ t_{pLH} - t_{pHL} $	$C_L = 30$ pF (Figure 3 and Figure 4)		0.5	5	3.5	5	ns

## 6.6 Driver Switching Characteristics: Single-Ended Characteristics

TEST CONDITIONS		MIN	TYP	MAX 8921	MAX 8921A	MAX 8921AT	UNIT
$t_{pLH}$	$C_L = 30$ pF (Figure 5 and Figure 6)		10	15	15	15	ns
$t_{pHL}$	$C_L = 30$ pF (Figure 5 and Figure 6)		10	15	15	15	ns
$t_{TLH}$	$C_L = 30$ pF (Figure 9 and Figure 10)		5	8	8	9.5	ns
$t_{THL}$	$C_L = 30$ pF (Figure 9 and Figure 10)		5	8	8	9.5	ns
Skew	$C_L = 30$ pF <sup>(1)</sup> (Figure 5 and Figure 6)		1	5	3.5	3.5	ns

(1) Difference between complementary outputs at the 50% point.

## 6.7 Driver Switching Characteristics: Differential Characteristics<sup>(1)</sup>

TEST CONDITIONS		MIN	TYP	MAX 8921	MAX 8921A	MAX 8921AT	UNIT
$t_{pLH}$	$C_L = 30$ pF (Figure 5, Figure 7, and Figure 8)		10	15	15	15	ns
$t_{pHL}$	$C_L = 30$ pF (Figure 5, Figure 7, and Figure 8)		10	15	15	15	ns
$ t_{pLH} - t_{pHL} $	$C_L = 30$ pF (Figure 5, Figure 7, and Figure 8)		0.5	6	2.75	2.75	ns

(1) Differential Delays are defined as calculated results from single ended rise and fall time measurements. This approach in establishing AC performance specifications has been taken due to limitations of available Automatic Test Equipment (ATE). The calculated ATE results assume a linear transition between measurement points and are a result of the following equations:  $T_{cr} = \frac{(T_{fb} \times T_{rb}) - (T_{ra} \times T_{fa})}{T_{rb} - T_{ra} - T_{fa} + T_{fb}}$  Where:  $T_{cr}$  = Crossing Point  $T_{ra}$ ,  $T_{rb}$ ,  $T_{fa}$  and  $T_{fb}$  are time measurements with respect to the input. See Figure 8.

## 6.8 Typical Characteristics

Test Setup: [Figure 5](#). Data Rate, Test Pattern: 2 Mbps, 1010 Pattern. T: 25°C

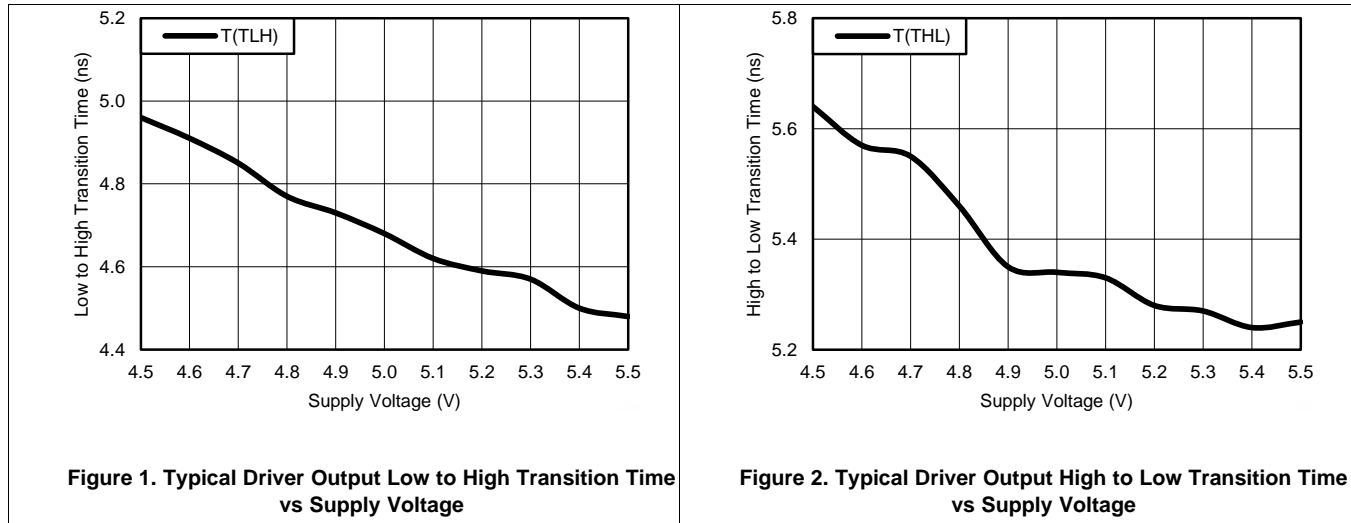

## 7 Parameter Measurement Information

### 7.1 AC Test Circuits and Switching Diagrams

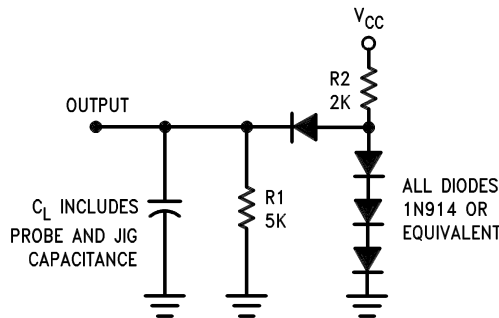

Figure 3. Test Circuit for Receiver Output

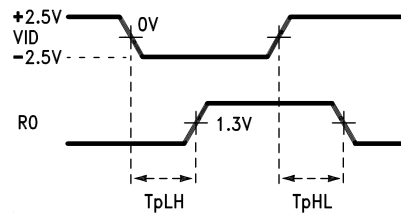

Figure 4. Receiver Propagation Delay

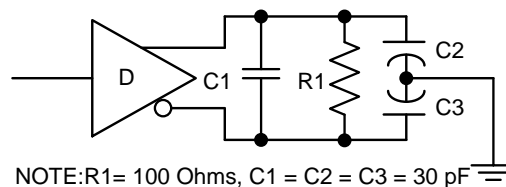

Figure 5. Driver Test Circuit

AC Test Circuits and Switching Diagrams (continued)

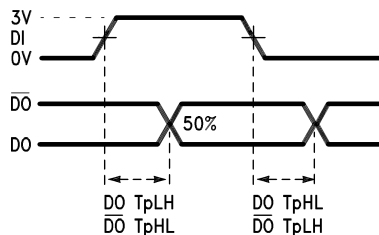

Figure 6. Driver Single-Ended Propagation Delay

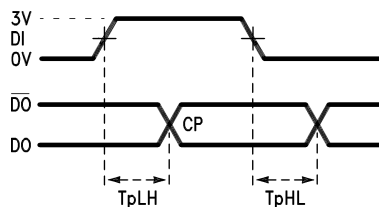

Figure 7. Driver Differential Propagation Delay

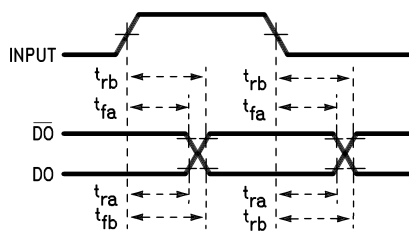

Figure 8. Driver Delay ATE Testing

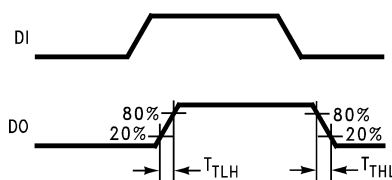

Figure 9. Driver Output Transition Time

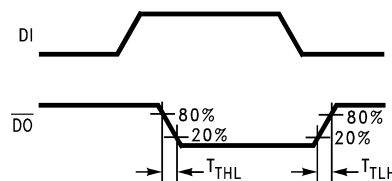

Figure 10. Driver Output Transition Time

## 8 Detailed Description

### 8.1 Overview

The DS8921x devices are each a differential line driver and receiver pair in a single package. The devices are designed specifically for ST506, ST412, and ESDI disk drive standards, as well as RS-422 interface applications. The DS8921 and DS8921A are rated at a commercial temperature range of 0°C to 70°C, whereas the DS8921AT is rated at an extended temperature range of -40°C to +85°C.

### 8.2 Functional Block Diagram

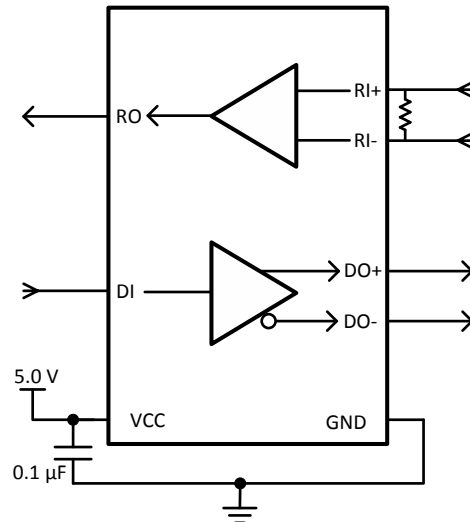

### 8.3 Feature Description

The DS8921x devices each contain a differential driver and receiver.

The driver converts a TTL or CMOS input to complementary outputs that provide differential drive to a twisted-pair or parallel wire transmission line. The receiver converts the differential signals at its input pins to a TTL output. The receiver offers an input sensitivity of  $\pm 200$  mV and supports a common-mode input voltage of  $\pm 7$  V.

### 8.4 Device Functional Modes

**Table 1. Function Table**

RECEIVER		DRIVER		
INPUT	OUTPUT	INPUT	OUTPUT	
RI+, RI-	RO	DI	DO+	DO-
$V_{ID}^{(1)} \geq V_{TH}(\text{MAX})$	1	1	1	0
$V_{ID}^{(1)} \leq V_{TH}(\text{MIN})$	0	0	0	1
Open	1			

(1)  $V_{ID}$  is the input differential voltage between RI+ and RI-.

## 9 Application and Implementation

### NOTE

Information in the following applications sections is not part of the TI component specification, and TI does not warrant its accuracy or completeness. TI's customers are responsible for determining suitability of components for their purposes. Customers should validate and test their design implementation to confirm system functionality.

### 9.1 Application Information

The DS8921 is a differential line driver and receiver pair in a single package, designed for applications for the ST506, ST412, and ESDI Disk Drive Standards. The DS8921 is compatible to EIA RS-422 signaling standards, supporting 200-mV input sensitivity across a  $\pm 7$ -V common mode operating range. This transceiver is intended for driving differential signal across long transmission lines and translating received differential signals into their CMOS/TTL single-ended equivalence. The DS8921 transmits and reproduces received data in communications links where ground reference difference, or noisy environment are common.

### 9.2 Typical Application

Figure 11 shows a typical implementation of the DS8921x device in a ST506 and ST412 disk drive application. The differential outputs of the driver are connected to a twisted-pair transmission line, carrying data from the driver to the differential receiver at the other end of the cable. A differential termination resistor should be connected across the input pins of the receiver.

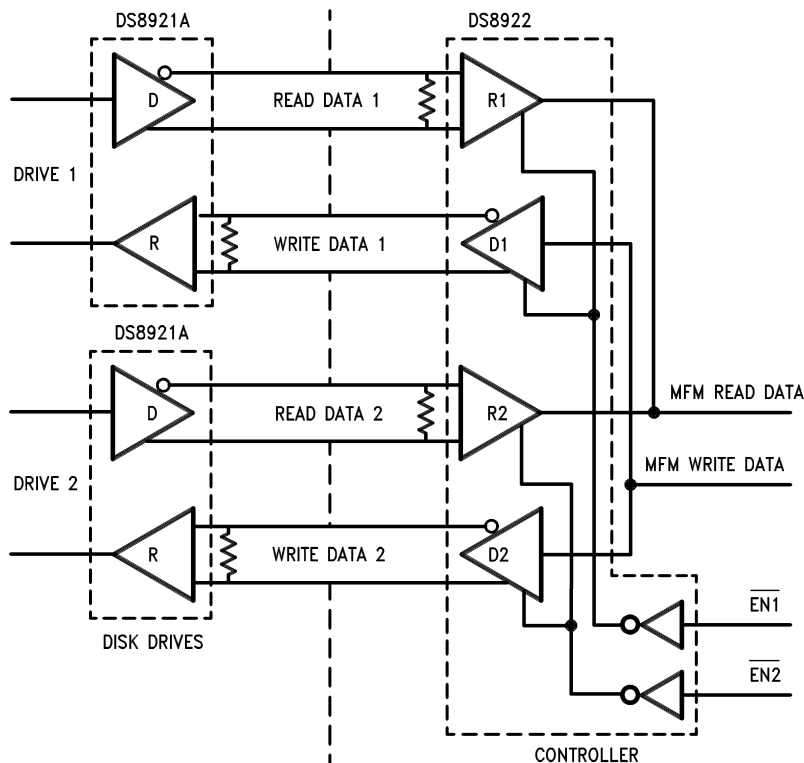

Figure 11. ST506 and ST412 Application

## Typical Application (continued)

### 9.2.1 Design Requirements

- Apply TTL or LVCMOS signal to driver input at DI
- Transmit complementary outputs at DO+ and DO-
- Receive complimentary input signals at RI+ and RI-
- Receive TTL output signal at RO
- Use controlled-impedance transmission lines such as printed circuit board traces, twisted-pair wires or parallel wire cable
- Place terminating resistor at the far end of the differential pair

### 9.2.2 Detailed Design Procedure

- Connect VCC and GND pins to the power and ground planes of the printed circuit board, with 0.1-uF bypass capacitor
- Use TTL/LVCMOS logic levels at DI and RO
- Use controlled-impedance transmission media for the differential signals DI+- and RO+-
- Place a terminating resistor at the far-end of the differential pair to avoid reflection
- Ensure the received complimentary signals at RO+ and RO- are within the signal threshold of  $\pm 200$  mV

### 9.2.3 Application Curves

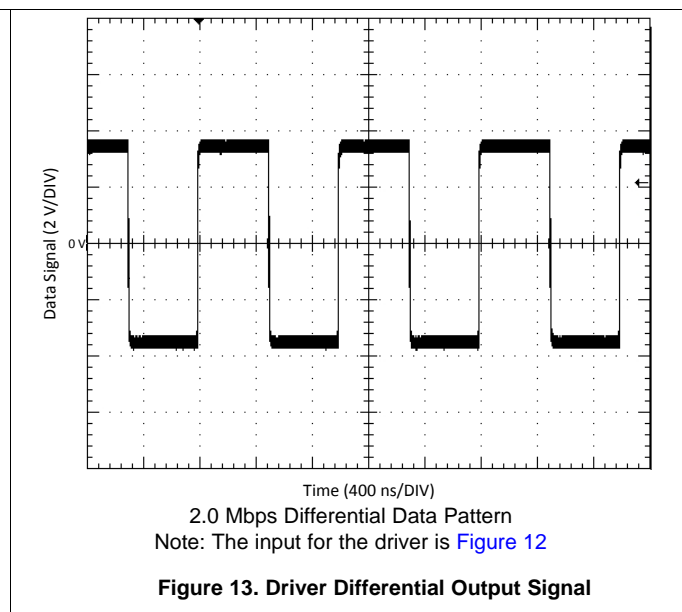
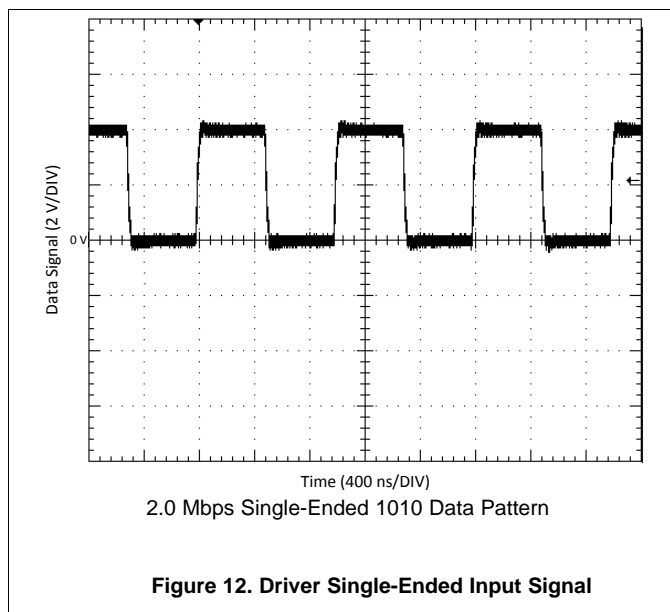

### Typical Application (continued)

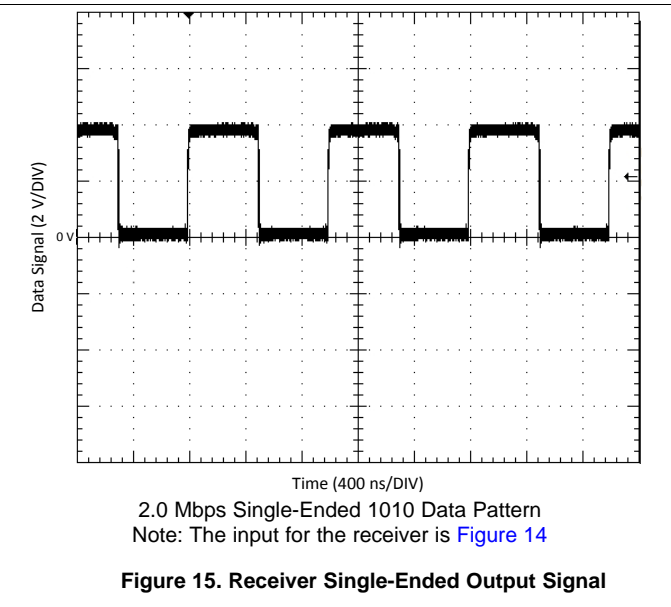
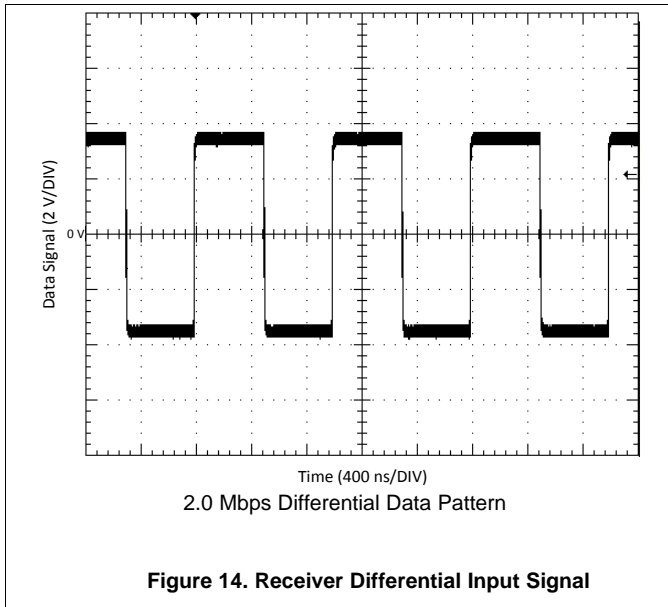

## 10 Power Supply Recommendations

TI recommends connecting the supply (VCC) and ground (GND) pins to power planes that are routed on adjacent layers of the PCB. Additionally, careful attention should be paid to bypassing the supply using a capacitor. A 0.1- $\mu$ F bypass capacitor should be connected to the VCC pin such that the capacitor is as close as possible to the device.

## 11 Layout

### 11.1 Layout Guidelines

High-speed interconnects should be treated as transmission lines with a controlled impedance. The differential interconnect can be a pair of printed-circuit board (PCB) traces, twisted-pair wires, or a parallel wire cable. A termination resistor should be placed at the differential input, and the resistor value should be approximately the same as the differential impedance of the transmission line to minimize reflections.

It is preferable to connect the VCC and GND pins to the power and ground planes using plated-through-holes. Additionally, a 0.1- $\mu$ F bypass capacitor should be placed close to the VCC pin across VCC and GND.

Place a terminating resistor at the receiving end of the interconnect transmission line, as close as possible to the input pins of the receiver. The terminating resistor value should be approximately the same as the differential pair impedance to minimize reflection, and the transmission line should have a controlled impedance with minimum impedance discontinuities.

The input and output differential signals of the device should have traces that are routed exclusively on one layer of the board, and the differential pairs should also be routed away from other differential pairs in order to minimize crosstalk between transmission lines. Additionally, the differential pairs should have a controlled impedance with minimum impedance discontinuities and be terminated with a resistor that is closely matched to the differential pair impedance in order to minimize transmission line reflections. The differential pairs should be routed with uniform trace width and spacing to minimize impedance mismatch.

### 11.2 Layout Example

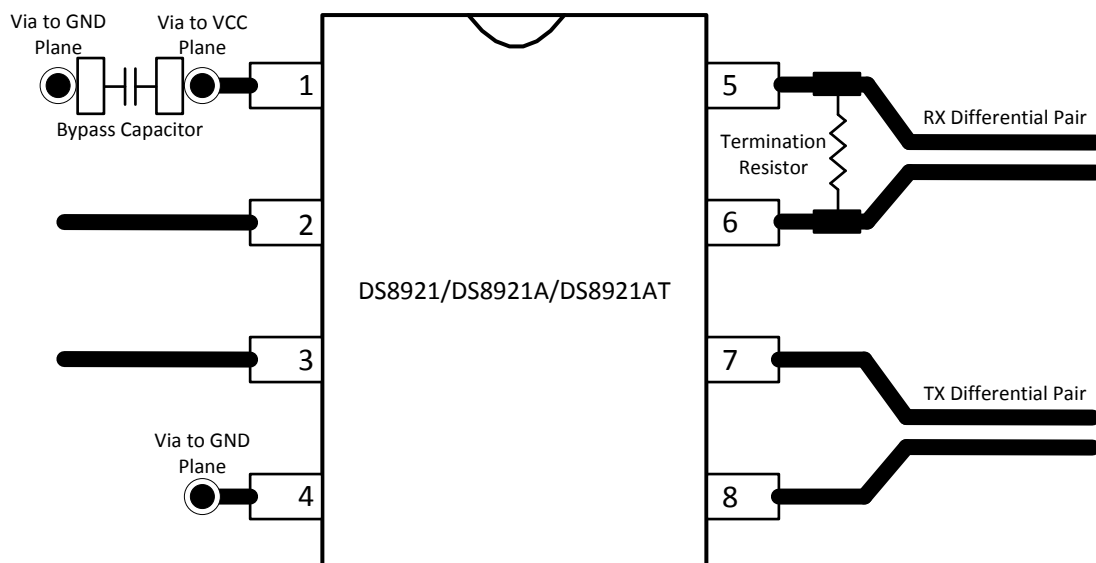

**Figure 16. DS8921 Example Layout**

## 12 Device and Documentation Support

### 12.1 Related Links

The table below lists quick access links. Categories include technical documents, support and community resources, tools and software, and quick access to sample or buy.

**Table 2. Related Links**

PARTS	PRODUCT FOLDER	SAMPLE & BUY	TECHNICAL DOCUMENTS	TOOLS & SOFTWARE	SUPPORT & COMMUNITY
DS8921	<a href="#">Click here</a>	<a href="#">Click here</a>	<a href="#">Click here</a>	<a href="#">Click here</a>	<a href="#">Click here</a>
DS8921A	<a href="#">Click here</a>	<a href="#">Click here</a>	<a href="#">Click here</a>	<a href="#">Click here</a>	<a href="#">Click here</a>
DS8921AT	<a href="#">Click here</a>	<a href="#">Click here</a>	<a href="#">Click here</a>	<a href="#">Click here</a>	<a href="#">Click here</a>

### 12.2 Trademarks

All trademarks are the property of their respective owners.

### 12.3 Electrostatic Discharge Caution



These devices have limited built-in ESD protection. The leads should be shorted together or the device placed in conductive foam during storage or handling to prevent electrostatic damage to the MOS gates.

### 12.4 Glossary

[SLYZ022](#) — *TI Glossary*.

This glossary lists and explains terms, acronyms, and definitions.

## 13 Mechanical, Packaging, and Orderable Information

The following pages include mechanical, packaging, and orderable information. This information is the most current data available for the designated devices. This data is subject to change without notice and revision of this document. For browser-based versions of this data sheet, refer to the left-hand navigation.

**PACKAGING INFORMATION**

Orderable Device	Status (1)	Package Type	Package Drawing	Pins	Package Qty	Eco Plan (2)	Lead/Ball Finish (6)	MSL Peak Temp (3)	Op Temp (°C)	Device Marking (4/5)	Samples
DS8921AM/NOPB	ACTIVE	SOIC	D	8	95	Green (RoHS & no Sb/Br)	CU SN	Level-1-260C-UNLIM	0 to 70	DS8921AM	<a href="#">Samples</a>
DS8921AMX/NOPB	ACTIVE	SOIC	D	8	2500	Green (RoHS & no Sb/Br)	CU SN	Level-1-260C-UNLIM	0 to 70	DS8921AM	<a href="#">Samples</a>
DS8921ATM/NOPB	ACTIVE	SOIC	D	8	95	Green (RoHS & no Sb/Br)	CU SN	Level-1-260C-UNLIM	-40 to 85	DS8921ATM	<a href="#">Samples</a>
DS8921M/NOPB	ACTIVE	SOIC	D	8	95	Green (RoHS & no Sb/Br)	CU SN	Level-1-260C-UNLIM	0 to 70	DS8921M	<a href="#">Samples</a>
DS8921MX/NOPB	ACTIVE	SOIC	D	8	2500	Green (RoHS & no Sb/Br)	CU SN	Level-1-260C-UNLIM	0 to 70	DS8921M	<a href="#">Samples</a>

(1) The marketing status values are defined as follows:

**ACTIVE:** Product device recommended for new designs.

**LIFEBUY:** TI has announced that the device will be discontinued, and a lifetime-buy period is in effect.

**NRND:** Not recommended for new designs. Device is in production to support existing customers, but TI does not recommend using this part in a new design.

**PREVIEW:** Device has been announced but is not in production. Samples may or may not be available.

**OBSELETE:** TI has discontinued the production of the device.

(2) **RoHS:** TI defines "RoHS" to mean semiconductor products that are compliant with the current EU RoHS requirements for all 10 RoHS substances, including the requirement that RoHS substance do not exceed 0.1% by weight in homogeneous materials. Where designed to be soldered at high temperatures, "RoHS" products are suitable for use in specified lead-free processes. TI may reference these types of products as "Pb-Free".

**RoHS Exempt:** TI defines "RoHS Exempt" to mean products that contain lead but are compliant with EU RoHS pursuant to a specific EU RoHS exemption.

**Green:** TI defines "Green" to mean the content of Chlorine (Cl) and Bromine (Br) based flame retardants meet JS709B low halogen requirements of <=1000ppm threshold. Antimony trioxide based flame retardants must also meet the <=1000ppm threshold requirement.

(3) MSL, Peak Temp. - The Moisture Sensitivity Level rating according to the JEDEC industry standard classifications, and peak solder temperature.

(4) There may be additional marking, which relates to the logo, the lot trace code information, or the environmental category on the device.

(5) Multiple Device Markings will be inside parentheses. Only one Device Marking contained in parentheses and separated by a "-" will appear on a device. If a line is indented then it is a continuation of the previous line and the two combined represent the entire Device Marking for that device.

(6) Lead/Ball Finish - Orderable Devices may have multiple material finish options. Finish options are separated by a vertical ruled line. Lead/Ball Finish values may wrap to two lines if the finish value exceeds the maximum column width.

**Important Information and Disclaimer:** The information provided on this page represents TI's knowledge and belief as of the date that it is provided. TI bases its knowledge and belief on information provided by third parties, and makes no representation or warranty as to the accuracy of such information. Efforts are underway to better integrate information from third parties. TI has taken and continues to take reasonable steps to provide representative and accurate information but may not have conducted destructive testing or chemical analysis on incoming materials and chemicals. TI and TI suppliers consider certain information to be proprietary, and thus CAS numbers and other limited information may not be available for release.

In no event shall TI's liability arising out of such information exceed the total purchase price of the TI part(s) at issue in this document sold by TI to Customer on an annual basis.

## TAPE AND REEL INFORMATION

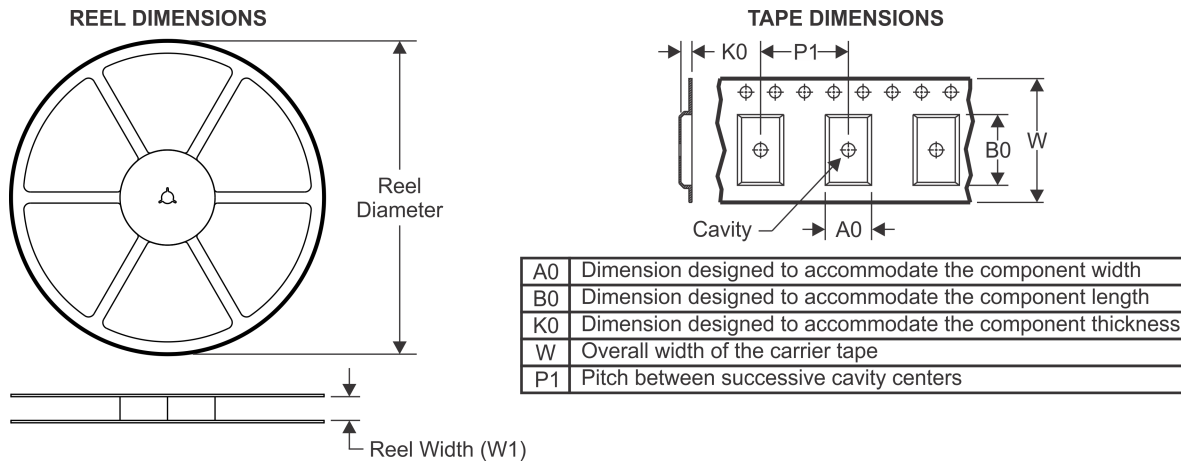

### QUADRANT ASSIGNMENTS FOR PIN 1 ORIENTATION IN TAPE



\*All dimensions are nominal

Device	Package Type	Package Drawing	Pins	SPQ	Reel Diameter (mm)	Reel Width W1 (mm)	A0 (mm)	B0 (mm)	K0 (mm)	P1 (mm)	W (mm)	Pin1 Quadrant
DS8921AMX/NOPB	SOIC	D	8	2500	330.0	12.4	6.5	5.4	2.0	8.0	12.0	Q1
DS8921MX/NOPB	SOIC	D	8	2500	330.0	12.4	6.5	5.4	2.0	8.0	12.0	Q1

**TAPE AND REEL BOX DIMENSIONS**

\*All dimensions are nominal

Device	Package Type	Package Drawing	Pins	SPQ	Length (mm)	Width (mm)	Height (mm)
DS8921AMX/NOPB	SOIC	D	8	2500	367.0	367.0	35.0
DS8921MX/NOPB	SOIC	D	8	2500	367.0	367.0	35.0



D0008A

# PACKAGE OUTLINE

SOIC - 1.75 mm max height

SMALL OUTLINE INTEGRATED CIRCUIT



4214825/C 02/2019

## NOTES:

- Linear dimensions are in inches [millimeters]. Dimensions in parenthesis are for reference only. Controlling dimensions are in inches. Dimensioning and tolerancing per ASME Y14.5M.
- This drawing is subject to change without notice.
- This dimension does not include mold flash, protrusions, or gate burrs. Mold flash, protrusions, or gate burrs shall not exceed  $.006$  [0.15] per side.
- This dimension does not include interlead flash.
- Reference JEDEC registration MS-012, variation AA.

# EXAMPLE BOARD LAYOUT

D0008A

SOIC - 1.75 mm max height

SMALL OUTLINE INTEGRATED CIRCUIT



LAND PATTERN EXAMPLE  
 EXPOSED METAL SHOWN  
 SCALE:8X



SOLDER MASK DETAILS

4214825/C 02/2019

NOTES: (continued)

- 6. Publication IPC-7351 may have alternate designs.
- 7. Solder mask tolerances between and around signal pads can vary based on board fabrication site.

# EXAMPLE STENCIL DESIGN

D0008A

SOIC - 1.75 mm max height

SMALL OUTLINE INTEGRATED CIRCUIT



SOLDER PASTE EXAMPLE  
BASED ON .005 INCH [0.125 MM] THICK STENCIL  
SCALE:8X

4214825/C 02/2019

NOTES: (continued)

8. Laser cutting apertures with trapezoidal walls and rounded corners may offer better paste release. IPC-7525 may have alternate design recommendations.
9. Board assembly site may have different recommendations for stencil design.

## IMPORTANT NOTICE AND DISCLAIMER

TI PROVIDES TECHNICAL AND RELIABILITY DATA (INCLUDING DATASHEETS), DESIGN RESOURCES (INCLUDING REFERENCE DESIGNS), APPLICATION OR OTHER DESIGN ADVICE, WEB TOOLS, SAFETY INFORMATION, AND OTHER RESOURCES "AS IS" AND WITH ALL FAULTS, AND DISCLAIMS ALL WARRANTIES, EXPRESS AND IMPLIED, INCLUDING WITHOUT LIMITATION ANY IMPLIED WARRANTIES OF MERCHANTABILITY, FITNESS FOR A PARTICULAR PURPOSE OR NON-INFRINGEMENT OF THIRD PARTY INTELLECTUAL PROPERTY RIGHTS.

These resources are intended for skilled developers designing with TI products. You are solely responsible for (1) selecting the appropriate TI products for your application, (2) designing, validating and testing your application, and (3) ensuring your application meets applicable standards, and any other safety, security, or other requirements. These resources are subject to change without notice. TI grants you permission to use these resources only for development of an application that uses the TI products described in the resource. Other reproduction and display of these resources is prohibited. No license is granted to any other TI intellectual property right or to any third party intellectual property right. TI disclaims responsibility for, and you will fully indemnify TI and its representatives against, any claims, damages, costs, losses, and liabilities arising out of your use of these resources.

TI's products are provided subject to TI's Terms of Sale ([www.ti.com/legal/termsofsale.html](http://www.ti.com/legal/termsofsale.html)) or other applicable terms available either on [ti.com](http://ti.com) or provided in conjunction with such TI products. TI's provision of these resources does not expand or otherwise alter TI's applicable warranties or warranty disclaimers for TI products.

Mailing Address: Texas Instruments, Post Office Box 655303, Dallas, Texas 75265  
Copyright © 2019, Texas Instruments Incorporated

## Looking for pricing, stock, or lifecycle information?

Click below to explore more details on WIN SOURCE:

- ⊖ [View DS8921ATM/NOPB on WIN SOURCE](#)
- ⊖ [Texas Instruments](#) Information

## Optimize Your Supply Chain with WIN SOURCE Solutions

- ✓ Global Sourcing Solution
- ✓ Obsolete Management
- ✓ Cost Control Management
- ✓ Shortage Management
- ✓ Alternative Solution
- ✓ Excess Inventory Management