

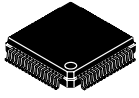

**THE DATASHEET OF
MC33771CTA1AER2**





PB_MC33771C

Battery cell controller IC

Rev. 1.0 — 20 January 2020

Product brief

1 General description

The MC33771C is a SMARTMOS lithium-ion battery cell controller IC designed for automotive applications, such as hybrid electric (HEV) and electric vehicles (EV) along with industrial applications, such as energy storage systems (ESS) and uninterruptible power supply (UPS) systems.

The device performs ADC conversions of the differential cell voltages and current, as well as battery coulomb counting and battery temperature measurements. The information is transmitted to MCU using one of the microcontroller interfaces (Serial Peripheral Interface (SPI) or Transformer physical layer (TPL)) of the IC.

2 Features

- $9.6\text{ V} \leq V_{PWR} \leq 61.6\text{ V}$ operation, 75 V transient
- 7 to 14 cells management
- Isolated 2.0 Mbps differential communication or 4.0 Mbps SPI
- Addressable on initialization
- Bi-directional transceiver to support up to 63 nodes in daisy chain
- 0.8 mV maximum total voltage measurement error
- Synchronized cell voltage/current measurement with coulomb count
- Averaging of cell voltage measurements
- Total stack voltage measurement
- Seven GPIO/temperature sensor inputs
- 5.0 V at 5.0 mA reference supply output
- Automatic over/undervoltage and temperature detection routable to fault pin
- Integrated sleep mode over/undervoltage and temperature monitoring
- Onboard 300 mA passive cell balancing with diagnostics
- Hot plug capable
- Detection of internal and external faults, as open lines, shorts, and leakages
- Designed to support ISO 26262, up to ASIL D safety system.
- Qualified in compliance with AECQ-100



3 Simplified application diagram

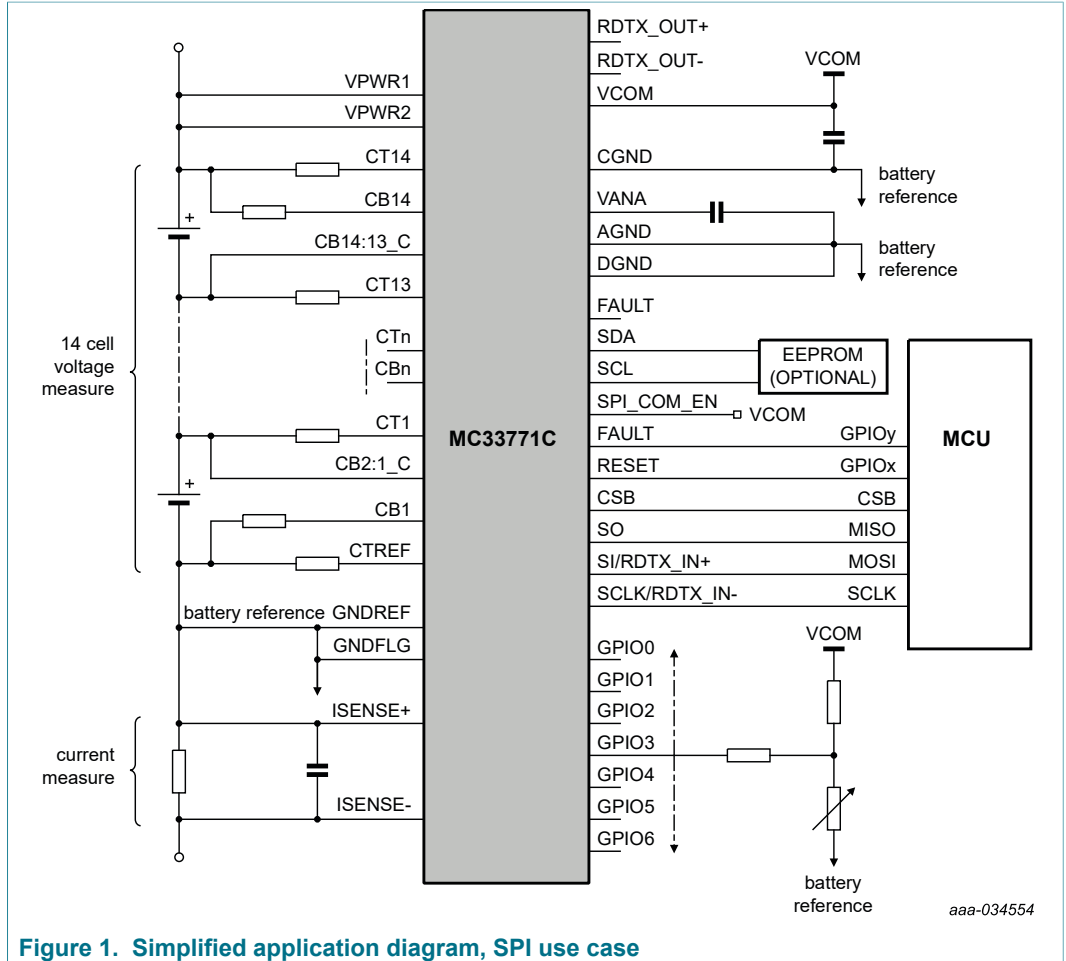
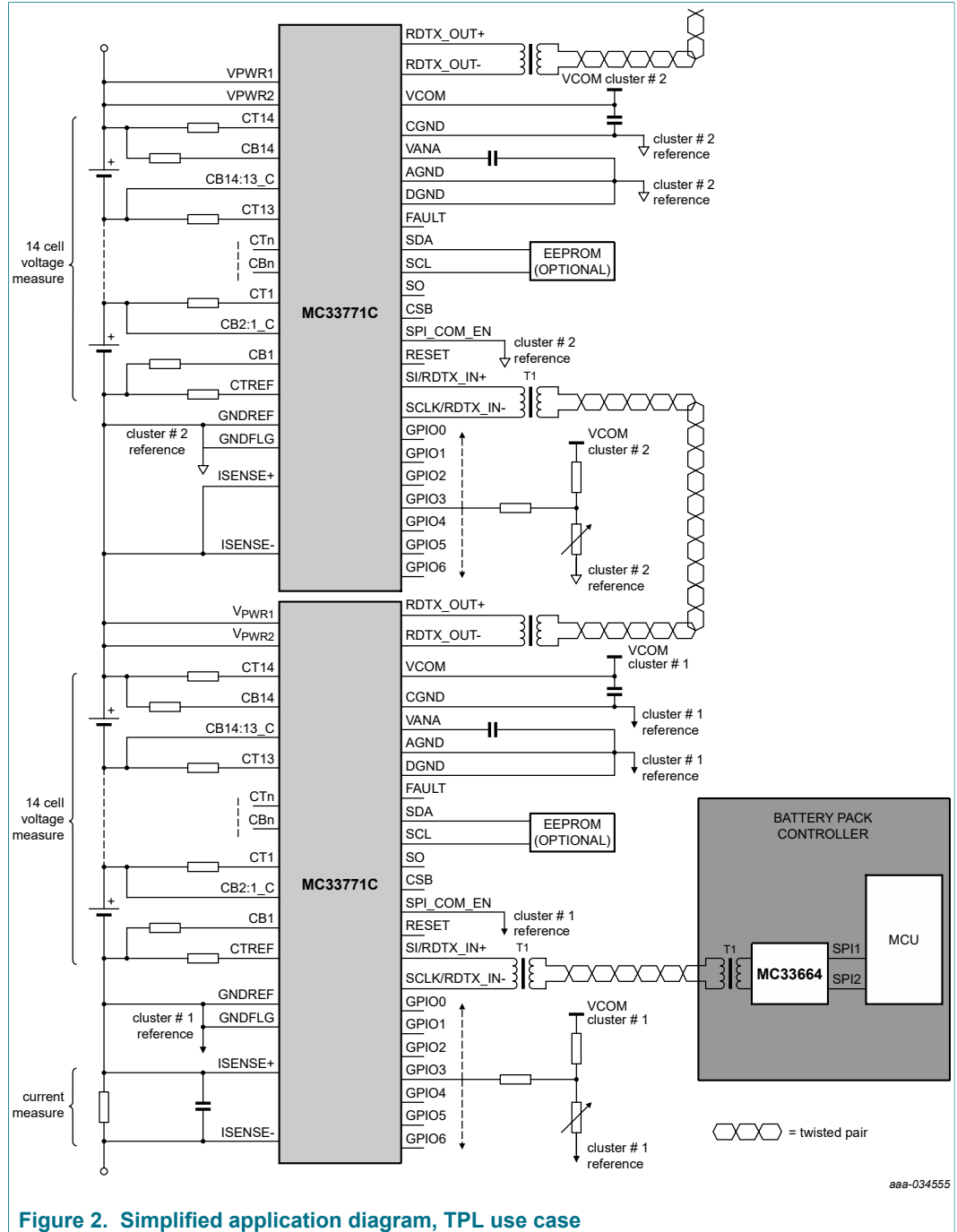

Figure 1. Simplified application diagram, SPI use case



4 Applications

- Automotive: 48 V and high-voltage battery packs
- E-bikes, e-scooters
- Energy storage systems
- Uninterruptible power supply (UPS)

5 Ordering information

5.1 Part numbers definition

MC33771C T/y z AE/R2

Table 1. Part number breakdown

Code	Option	Description
	T	TPL communication type
y	P	y = P (Premium with current measurement option)
	A	y = A (Advanced)
z	1	z = 1 (7 to 14 channels)
	2	z = 2 (7 to 8 channels)
	AE	Package suffix
	R2	Tape and reel indicator

5.2 Part numbers list

This section describes the part numbers available to be purchased along with their differences. Valid orderable part numbers are provided on the web. To determine the orderable part numbers for this device, go to <http://www.nxp.com>.

Table 2. Advanced orderable part table

Temperature range is -40 to 105 °C

Package type is 64-pin LQFP-EP

Orderable part	Number of channels	OV/UV	Precision GPIO as temperature channels and OT/UT	Current channel or coulomb count
TPL differential communication protocol				
MC33771CTA1AE	7 to 14	Yes	Yes	No
MC33771CTA2AE	7 to 8	Yes	Yes	No

Table 3. Premium orderable part table

Temperature range is -40 to 105 °C

Package type is 64-pin LQFP-EP

Orderable part	Number of channels	OV/UV	Precision GPIO as temperature channels and OT/UT	Current channel or coulomb count
TPL differential communication protocol with current measurement option				
MC33771CTP1AE	7 to 14	Yes	Yes	Yes
MC33771CTP2AE	7 to 8	Yes	Yes	Yes

6 Pinning information

6.1 Pinout diagram

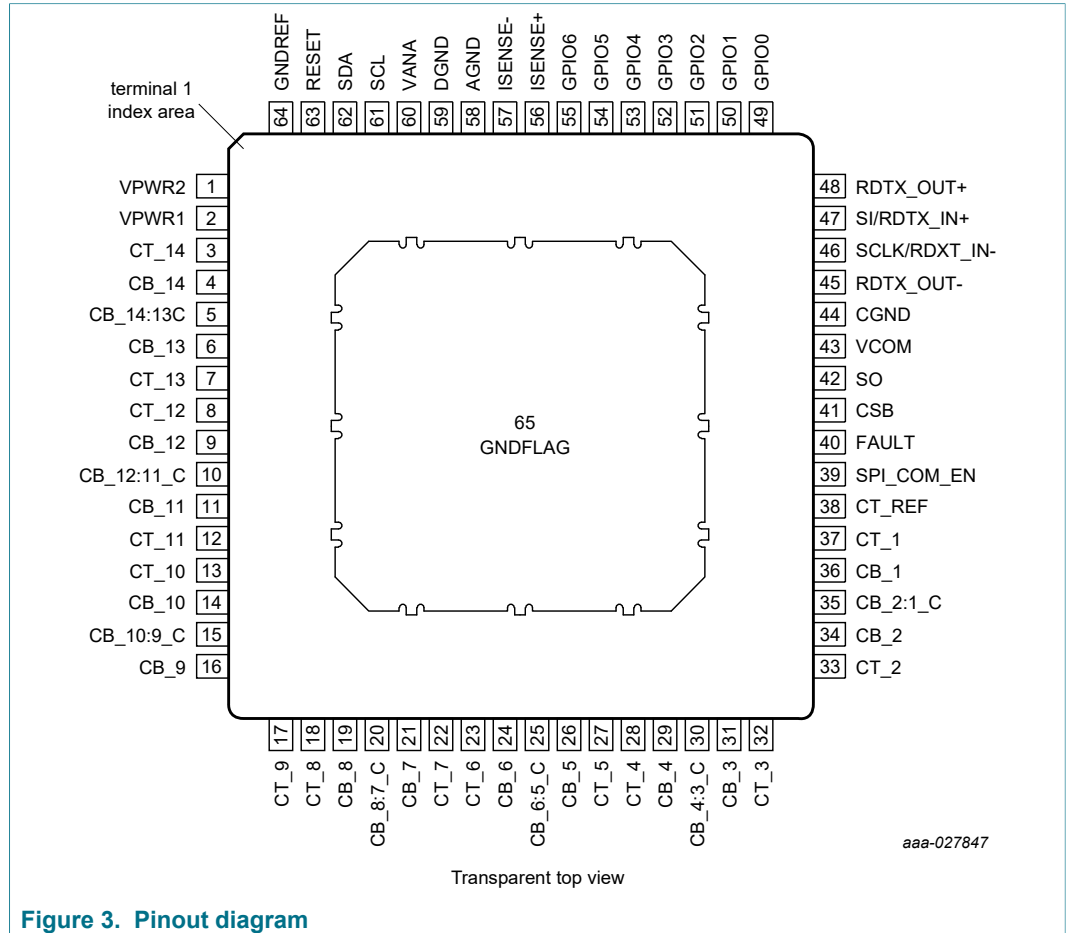

Figure 3. Pinout diagram

6.2 Pin definitions

Table 4. Pin definitions

Number	Name	Function	Definition
1	VPWR2	Input	Power input to the MC33771C
2	VPWR1	Input	Power input to the MC33771C
3	CT_14	Input	Cell pin 14 input. Terminate to LPF resistor.
4	CB_14	Output	Cell balance driver. Terminate to cell 14 cell balance load resistor.
5	CB_14:13_C	Output	Cell balance 14:13 common. Terminate to CB_14:13_C balance load resistor.
6	CB_13	Output	Cell balance driver. Terminate to cell 13 cell balance load resistor.
7	CT_13	Input	Cell pin 13 input. Terminate to LPF resistor.
8	CT_12	Input	Cell pin 12 input. Terminate to LPF resistor.

Number	Name	Function	Definition
9	CB_12	Output	Cell balance driver. Terminate to cell 12 cell balance load resistor.
10	CB_12:11_C	Output	Cell balance 12:11 common. Terminate to CB_12:11_C balance load resistor.
11	CB_11	Output	Cell balance driver. Terminate to cell 11 cell balance load resistor.
12	CT_11	Input	Cell pin 11 input. Terminate to LPF resistor.
13	CT_10	Input	Cell pin 10 input. Terminate to LPF resistor.
14	CB_10	Output	Cell balance driver. Terminate to cell 10 cell balance load resistor.
15	CB_10:9_C	Output	Cell balance 10:9 common. Terminate to CB_10:9_C balance load resistor.
16	CB_9	Output	Cell balance driver. Terminate to cell 9 cell balance load resistor.
17	CT_9	Input	Cell pin 9 input. Terminate to LPF resistor.
18	CT_8	Input	Cell pin 8 input. Terminate to LPF resistor.
19	CB_8	Output	Cell balance driver. Terminate to cell 8 cell balance load resistor.
20	CB_8:7_C	Output	Cell balance 8:7 common. Terminate to CB_8:7_C balance load resistor.
21	CB_7	Output	Cell balance driver. Terminate to cell 7 cell balance load resistor.
22	CT_7	Input	Cell pin 7 input. Terminate to LPF resistor.
23	CT_6	Input	Cell pin 6 input. Terminate to LPF resistor.
24	CB_6	Output	Cell balance driver. Terminate to cell 6 cell balance load resistor.
25	CB_6:5_C	Output	Cell balance 6:5 common. Terminate to CB_6:5_C balance load resistor.
26	CB_5	Output	Cell balance driver. Terminate to cell 5 cell balance load resistor.
27	CT_5	Input	Cell pin 5 input. Terminate to LPF resistor.
28	CT_4	Input	Cell pin 4 input. Terminate to LPF resistor.
29	CB_4	Output	Cell balance driver. Terminate to cell 4 cell balance load resistor.
30	CB_4:3_C	Output	Cell balance 4:3 common. Terminate to CB_4:3_C balance load resistor.
31	CB_3	Output	Cell balance driver. Terminate to cell 3 cell balance load resistor.
32	CT_3	Input	Cell pin 3 input. Terminate to LPF resistor.
33	CT_2	Input	Cell pin 2 input. Terminate to LPF resistor.
34	CB_2	Output	Cell balance driver. Terminate to cell 2 cell balance load resistor.

Number	Name	Function	Definition
35	CB_2:1_C	Output	Cell Balance 2:1 common. Terminate to CB_2:1_C balance load resistor.
36	CB_1	Output	Cell balance driver. Terminate to cell 1 cell balance load resistor.
37	CT_1	Input	Cell pin 1 input. Terminate to LPF resistor.
38	CT_REF	Input	Cell pin REF input. Terminate to LPF resistor.
39	SPI_COM_EN	Input	SPI communication enable. Pin must be high for the SPI to be active.
40	FAULT	Output	Fault output dependent on user defined internal or external faults. If not used, it must be left open.
41	CSB	Input	SPI chip select
42	SO	Output	SPI serial output
43	VCOM	Output	Communication regulator output
44	CGND	Ground	Communication decoupling ground. Terminate to GNDREF.
45	RDTX_OUT-	I/O	Receive/transmit output negative
46	SCLK/RDTX_IN-	I/O	SPI clock or receive/transmit input negative
47	SI/RDTX_IN+	I/O	SPI serial input or receive/transmit input positive
48	RDTX_OUT+	I/O	Receive/transmit output positive
49	GPIO0	I/O	General purpose analog input or GPIO or wake-up or fault daisy chain
50	GPIO1	I/O	General purpose analog input or GPIO
51	GPIO2	I/O	General purpose analog input or GPIO or conversion trigger
52	GPIO3	I/O	General purpose analog input or GPIO
53	GPIO4	I/O	General purpose analog input or GPIO
54	GPIO5	I/O	General purpose analog input or GPIO
55	GPIO6	I/O	General purpose analog input or GPIO
56	ISENSE+	Input	Current measurement input+
57	ISENSE-	Input	Current measurement input-
58	AGND	Ground	Analog ground, terminate to GNDREF
59	DGND	Ground	Digital ground, terminate to GNDREF
60	VANA	Output	Precision ADC analog supply
61	SCL	I/O	I ² C clock
62	SDA	I/O	I ² C data
63	RESET	Input	RESET is an active high input. RESET has an internal pull down. If not used, it can be tied to GND.

Number	Name	Function	Definition
64	GNDREF	Ground	Ground reference for device. Terminate to reference of battery cluster.
65	GNDFLAG	Ground	Device flag. Terminate to lowest potential of battery cluster.

7 General product characteristics

7.1 Ratings and operating requirements relationship

The operating voltage range pertains to the VPWR pins referenced to the AGND pins.

Table 5. Ratings vs. operating requirements

Fatal range • Permanent failure might occur	Handling range – no permanent failure			Fatal range • Permanent failure might occur
	Lower limited operating range • No permanent failure, but IC functionality is not guaranteed	Normal operating range • 100 % functional	Upper limited operating range • IC parameters might be out of specification • Detection of V _{PWR} overvoltage is functional	
V _{PWR} < -0.3 V	7.6 V ≤ V _{PWR} < 9.6 V Reset range: -0.3 V ≤ V _{PWR} < 7.6 V	9.6 V ≤ V _{PWR} ≤ 61.6 V	61.6 V < V _{PWR} ≤ 75 V	75 V < V _{PWR}

In both upper and lower limited operating range, no information can be provided about IC performance. Only the detection of V_{PWR} overvoltage is guaranteed in the upper limited operating range.

Performance in normal operating range is guaranteed only if there is a minimum of seven battery cells in the stack.

7.2 Maximum ratings

Table 6. Maximum ratings

All voltages are with respect to ground unless otherwise noted. Exceeding these ratings may cause a malfunction or permanent damage to the device.

Symbol	Description (rating)	Min	Max	Unit
Electrical ratings				
VPWR1, VPWR2	Supply input voltage	-0.3	75	V
CT14	Cell terminal voltage	-0.3	75	V
VPWR to CT14	Voltage across VPWR1,2 pins pair and CT14 pin	-10	10.5	V
CT _N to CT _{N-1}	Cell terminal differential voltage	^[1] -0.3	6.0	V
CT _{REF} to GND	Cell terminal reference to ground	—	5	V
CT _N to GND	Cell terminal voltage to ground (N=1 to 4 or N=6 to 14)	—	(N+1) . 5	V
	Cell terminal voltage to ground (N=5)	—	27.5	V
CT _{N(CURRENT)}	Cell terminal input current	—	±500	µA
CB _N to CB _{N:N-1_C} CB _{N:N-1_C} to CB _{N-1}	Cell balance differential voltage	—	10	V

Symbol	Description (rating)	Min	Max	Unit
CB _{2n} to GND	Cell balance voltage to GND (n=1 to 7)	—	(2n+1) . 5	V
CB _{2n+1} to GND	Cell balance voltage to GND (n=0 to 6)	—	(2n+1) . 5	V
CB _{2n:2n-1_C} to GND	Cell balance voltage to GND (n=1 to 6)	—	2n . 5	V
CB _{N:N-1_C} to CT _{N-1}	Cell balance input to cell terminal input	-10	10	V
VISENSE	ISENSE+ and ISENSE- pin voltage	-0.3	2.5	V
VCOM	Maximum voltage may be applied to VCOM pin from external source	—	5.8	V
VANA	Maximum voltage may be applied to VANA pin	—	3.1	V
V _{GPIO0}	GPIO0 pin voltage	-0.3	6.5	V
V _{GPIOx}	GPIOx pins (x = 1 to 6) voltage	-0.3	VCOM + 0.5	V
V _{DIG}	Voltage I ² C pins (SDA, SCL)	-0.3	VCOM + 0.5	V
V _{RESET}	RESET pin	-0.3	6.5	V
V _{CSB}	CSB pin	-0.3	6.5	V
V _{SPI_COMM_EN}	SPI_COMM_EN	-0.3	6.5	V
V _{SO}	SO pin	-0.3	VCOM + 0.5	V
V _{GPIO5,6}	Maximum voltage for GPIO5 and GPIO6 pins used as current input	-0.3	2.5	V
FAULT	Maximum applied voltage to pin	-0.3	7.0	V
I _{pin_unpowered}	Input current in a pin when the device is unpowered	-2	2	mA
V _{COMM}	Maximum voltage to pins RDTX_OUT+, RDTX_OUT-, SI/RDTX_IN+, SCLK/RDTX_IN-	-10.0	10.0	V
V _{ESD1}	ESD voltage Human body model (HBM) Charge device model (CDM) Charge device model corner pins (CDM)	— — —	±2000 ±500 [2] ±750	V
V _{ESD2}	ESD voltage (VPWR1, VPWR2, CTx, CBx, GPIOx, ISENSE+, ISENSE-, RDTX_OUT+, RDTX_OUT-, SI/RDTX_IN+, SCLK/RDTX_IN-) versus all ground pins Human body model (HBM)	[3] —	±4000	V
V _{ESD3}	ESD voltage (CTREF, CTx, CBx, GPIOx, ISENSE+, ISENSE-, RDTX_OUT+, RDTX_OUT-, SI/RDTX_IN+, SCLK/RDTX_IN-) IEC 61000-4-2, Unpowered (Gun configuration: 330Ω / 150pF) HMM, Unpowered (Gun configuration: 330Ω / 150pF) ISO 10605:2009, Unpowered (Gun configuration: 2 kΩ / 150pF) ISO 10605:2009, Powered (Gun configuration: 2 kΩ / 150pF)	[4] — — — —	±8000 ±8000 ±8000 ±8000	V

[1] Adjacent CT pins may experience an overvoltage that exceeds their maximum rating during OV/UV functional verification test or during open line diagnostic test. Nevertheless, the IC is completely tolerant to this special situation.
 [2] For CT_REF pin applicable limit is ±450 V.
 [3] ESD testing is performed in accordance with the human body model (HBM) (C_{ZAP} = 100 pF, R_{ZAP} = 1500 Ω), and the charge device model (CDM) (C_{ZAP} = 4.0 pF).
 [4] These voltage values can be sustained only if ESD caps are used as described in [MC33771C External Components](#)

7.3 Thermal characteristics

Table 7. Thermal ratings

All voltages are with respect to ground unless otherwise noted. Exceeding these ratings may cause a malfunction or permanent damage to the device.

Symbol	Description (rating)	Min	Max	Unit
Thermal ratings				
T_A	Operating temperature Ambient	-40	+105	°C
T_J	Junction ^[1]	-40	+150	
T_{STG}	Storage temperature	-55	+150	°C
T_{PPRT}	Peak package reflow temperature	[2] [3]	260	°C
Thermal resistance and package dissipation ratings				
$R_{\theta JB}$	Junction-to-board (bottom exposed pad soldered to board) 64 LQFP EP	[4]	10	°C/W
$R_{\theta JA}$	Junction-to-ambient, natural convection, single-layer board (1s) 64 LQFP EP	[5] [6]	59	°C/W
$R_{\theta JA}$	Junction-to-ambient, natural convection, four-layer board (2s2p) 64 LQFP EP	[5] [6]	27	°C/W
$R_{\theta JCTOP}$	Junction-to-case top (exposed pad) 64 LQFP EP	[7]	14	°C/W
$R_{\theta JCBOTTOM}$	Junction-to-case bottom (exposed pad) 64 LQFP EP	[8]	0.97	°C/W
Ψ_{JT}	Junction to package top, natural convection	[9]	3	°C/W

- [1] The user must ensure that the average maximum operating junction temperature (T_J) is not exceeded.
- [2] Pin soldering temperature limit is for 10 seconds maximum duration. Not designed for immersion soldering. Exceeding these limits may cause a malfunction or permanent damage to the device.
- [3] NXP's Package Reflow capability meets Pb-free requirements for JEDEC standard J-STD-020C. For Peak Package Reflow Temperature and Moisture Sensitivity Levels (MSL), go to www.nxp.com, search by part number (remove prefixes/suffixes) and enter the core ID to view all orderable parts and review parametrics.
- [4] Thermal resistance between the die and the printed circuit board per JEDEC JESD51-8. Board temperature is measured on the top surface of the board near the package.
- [5] Junction temperature is a function of die size, on-chip power dissipation, package thermal resistance, mounting site (board) temperature, ambient temperature, air flow, power dissipation of other components on the board, and board thermal resistance.
- [6] Per JEDEC JESD51-6 with the board (JESD51-7) horizontal.
- [7] Thermal resistance between the die and the case top surface as measured by the cold plate method (MIL SPEC-883 Method 1012.1), with the cold plate temperature used for the case temperature.
- [8] Thermal resistance between the die and the solder pad on the bottom of the package based on simulation without any interface resistance.
- [9] Thermal characterization parameter indicating the temperature difference between the package top and the junction temperature per JEDEC JESD51-2.

7.4 Electrical characteristics

Table 8. Static and dynamic electrical characteristics

Characteristics noted under conditions $9.6\text{ V} \leq V_{PWR} \leq 61.6\text{ V}$, $-40\text{ °C} \leq T_A \leq 105\text{ °C}$, $GND = 0\text{ V}$, unless otherwise stated. Typical values refer to $V_{PWR} = 56\text{ V}$, $T_A = 25\text{ °C}$, unless otherwise noted.

Symbol	Parameter	Min	Typ	Max	Unit
Power management					
$V_{PWR(FO)}$	Supply voltage Full parameter specification	9.6	—	61.6	V

Symbol	Parameter	Min	Typ	Max	Unit
I _{VPWR}	Supply current (base value) Normal mode, cell balance OFF, ADC inactive, SPI communication inactive, IVCOM = 0 mA	—	5.4	—	mA
	Normal mode, cell balance OFF, ADC inactive, TPL communication inactive, IVCOM = 0 mA	—	8.0	—	
I _{VPWR(TPL_TX)}	Supply current adder when TPL communication active	—	—	16	mA
I _{VPWR(CBON)}	Supply current adder to set all 14 cell balance switches ON	—	0.97	—	mA
I _{VPWR(ADC)}	Delta supply current to perform ADC conversions (addend) ADC1-A,B continuously converting ADC2 continuously converting	—	3.0	—	mA
		—	1.4	—	
I _{VPWR(SS)}	Supply current in sleep mode and in idle mode, communication inactive, cell balance off, cyclic measurement off, oscillator monitor on SPI mode (25 °C) TPL mode (T _A = 25 °C)	—	40	—	μA
		64	—	108	
		—	—	—	
I _{VPWR(CKMON)}	Clock monitor current consumption	—	5	—	μA
V _{PWR(OV_FLAG)}	V _{PWR} overvoltage fault threshold (flag)	—	65	—	V
V _{PWR(LV_FLAG)}	V _{PWR} low-voltage warning threshold (flag)	—	12	—	V
V _{PWR(UV_POR)}	V _{PWR} undervoltage shutdown threshold (POR)	—	8.5	—	V
V _{PWR(HYS)}	V _{PWR} UV hysteresis voltage	—	200	—	mV
t _{VPWR(FILTER)}	V _{PWR} OV, LV filter	—	50	—	μs
VCOM power supply					
V _{COM}	VCOM output voltage	—	5.0	—	V
I _{VCOM}	VCOM output current allocated for external use	—	—	5.0	mA
V _{COM(UV)}	VCOM undervoltage fault threshold	—	4.4	—	V
V _{COM_HYS}	VCOM undervoltage hysteresis	—	100	—	mV
t _{VCOM(FLT_TIMER)}	VCOM undervoltage fault timer	—	10	—	μs
t _{VCOM(RETRY)}	VCOM fault retry timer	—	10	—	ms
V _{COM(OV)}	VCOM overvoltage fault threshold	5.4	—	5.9	V
I _{LIM_VCOM(OC)}	VCOM current limit	65	—	140	mA
R _{VCOM(SS)}	VCOM sleep mode pull-down resistor	—	2.0	—	kΩ
t _{VCOM}	VCOM rise time (for V _{PWR} > 10V and CL = 2.2 μF (ceramic X7R only) in parallel with 220 pF)	—	—	440	μs
VANA power supply					
V _{ANA}	VANA output voltage (not used by external circuits) Decouple with 47 nF X7R 0603 or 0402	—	2.65	—	V
V _{ANA(UV)}	VANA undervoltage fault threshold	—	2.4	—	V
V _{ANA_HYS}	VANA undervoltage hysteresis	—	50	—	mV
V _{ANA(FLT_TIMER)}	VANA undervoltage fault timer	—	11	—	μs
V _{ANA(OV)}	VANA overvoltage fault threshold	—	2.8	—	V
t _{VANA(RETRY)}	VANA fault retry timer	—	10	—	ms
I _{LIM_VANA(OC)}	VANA current limit	5.0	—	10	mA
R _{VANA_RPD}	VANA sleep mode pull-down resistor	—	1.0	—	kΩ

Symbol	Parameter	Min	Typ	Max	Unit
t _{VANA}	VANA rise time (CL = 47 nF ceramic X7R only)	—	—	400	µs
ADC1-A, ADC1-B					
CT _{n(LEAKAGE)}	Cell terminal input leakage current (except in SLEEP mode when cell balancing is ON)	—	10	—	nA
CT _{n(FV)}	Cell terminal input current - functional verification	—	0.365	—	mA
CT _N	Cell terminal input current during conversion	—	50	—	nA
R _{PD}	Cell terminal open load detection pull-down resistor	—	950	—	Ω
V _{VPWR_RES}	VPWR terminal measurement resolution	—	2.44141	—	mV/LSB
V _{VPWR_RNG}	VPWR terminal measurement range	9.6	—	75	V
VPWR _{TERM_ERR}	VPWR terminal measurement accuracy	-0.5	—	0.5	%
V _{CT_RNG}	ADC differential input voltage range for CT _n to CT _{n-1}	0.0	—	4.85	V
V _{CT_ANx_RES}	Cell voltage and ANx resolution in 15-bit MEAS_xxxx registers	—	152.58789	—	µV/LSB
V _{ANx_RATIO_RES}	ANx resolution in 15-bit MEAS_xxxx registers in ratiometric mode	—	VCOM. (30.51851)	—	µV/LSB
V _{ERR33RT}	Cell voltage measurement error V _{CELL} = 3.3 V, T _A = 25 °C	-0.8	±0.4	0.8	mV
V _{ERR}	Cell voltage measurement error 0.1 V ≤ V _{CELL} ≤ 4.8 V, -40 °C ≤ T _A ≤ 105 °C (or -40 °C ≤ T _J ≤ 125 °C)	—	±0.7	—	mV
V _{ERR_1}	Cell voltage measurement error 0 V ≤ V _{CELL} ≤ 1.5 V, -40 °C ≤ T _A ≤ 60 °C (or -40 °C ≤ T _J ≤ 85 °C)	—	±0.4	—	mV
V _{ERR_2}	Cell voltage measurement error 1.5 V ≤ V _{CELL} ≤ 2.7 V, -40 °C ≤ T _A ≤ 60 °C (or -40 °C ≤ T _J ≤ 85 °C)	—	±0.4	—	mV
V _{ERR_3}	Cell voltage measurement error 2.7 V ≤ V _{CELL} ≤ 3.7 V, -40 °C ≤ T _A ≤ 60 °C (or -40 °C ≤ T _J ≤ 85 °C)	—	±0.5	—	mV
V _{ERR_4}	Cell voltage measurement error 3.7 V ≤ V _{CELL} ≤ 4.3 V, -40 °C ≤ T _A ≤ 60 °C (or -40 °C ≤ T _J ≤ 85 °C)	—	±0.7	—	mV
V _{ERR_5}	Cell voltage measurement error 1.5 V ≤ V _{CELL} ≤ 4.5 V, -40 °C ≤ T _A ≤ 105 °C (or -40 °C ≤ T _J ≤ 125 °C)	—	±0.7	—	mV
V _{ANx_ERR}	Magnitude of ANx error in the entire measurement range: Ratiometric measurement Absolute measurement after soldering and aging, input in the range [1.0, 4.5] V Absolute measurement after soldering and aging, input in the range [0, 4.85] V, for -40 °C < T _A < 60 °C Absolute measurement after soldering and aging, input in the range [0, 4.85] V, for -40 °C < T _A < 105 °C	— — -8.0 -11	— — — —	16 10 8.0 11	mV
t _{VCONV}	Single channel net conversion time 13-bit resolution 14-bit resolution 15-bit resolution 16-bit resolution	— — — —	6.77 9.43 14.75 25.36	— — — —	µs

Symbol	Parameter	Min	Typ	Max	Unit
V _{V_NOISE}	Conversion noise				μVrms
	13-bit resolution	—	1800	—	
	14-bit resolution	—	1000	—	
	15-bit resolution	—	600	—	
	16-bit resolution	—	400	—	
ADC2/current sense module					
V _{INC}	ISENSE+/ISENSE- input voltage (reference to AGND)	-300	—	300	mV
V _{IND}	ISENSE+/ISENSE- differential input voltage range	-150	—	150	mV
V _{ISENSEX(OFFSET)}	ISENSE+/ISENSE- input voltage offset error	—	—	0.5	μV
I _{ISENSEX(BIAS)}	ISENSE+/ISENSE- input bias current	-100	—	100	nA
I _{ISENSE(DIF)}	ISENSE+/ISENSE- differential input bias current	-5.0	—	5.0	nA
I _{GAINERR}	ISENSE error including nonlinearities	-0.5	—	0.5	%
I _{ISENSE_OL}	ISENSE open load injected current	—	130	—	μA
V _{ISENSE_OL}	ISENSE open load detection threshold	—	460	—	mV
V _{2RES}	Current sense user register resolution	—	0.6	—	μV/LSB
V _{PGA_SAT}	PGA saturation half-range				mV
	Gain = 256	—	4.9	—	
	Gain = 64	—	19.5	—	
	Gain = 16	—	78.1	—	
	Gain = 4	—	150.0	—	
V _{PGA_ITH}	Voltage threshold for PGA gain increase				mV
	Gain = 256	—	—	—	
	Gain = 64	—	2.344	—	
	Gain = 16	—	9.375	—	
	Gain = 4	—	37.50	—	
V _{PGA_DTH}	Voltage threshold for PGA gain decrease				mV
	Gain = 256	—	4.298	—	
	Gain = 64	—	17.188	—	
	Gain = 16	—	68.750	—	
	Gain = 4	—	—	—	
t _{AZC_SETTLE}	Time to perform auto-zero procedure after enabling the current channel	—	200	—	μs
t _{ICONV}	ADC conversion time including PGA settling time				μs
	13 bit resolution	—	19.00	—	
	14 bit resolution	—	21.67	—	
	15 bit resolution	—	27.00	—	
	16 bit resolution	—	37.67	—	
V _{I_NOISE}	Noise error at 16-bit conversion	—	3.01	—	μVrms
V _{I_NOISE}	Noise error at 13-bit conversion	—	8.33	—	μVrms
ADC _{CLK}	ADC2 and ADC1-A,B clocking frequency	—	6.0	—	MHz
Cell balance drivers					
V _{DS(CLAMP)}	Cell balance driver VDS active clamp voltage	—	11	—	V
V _{OUT(FLT_TH)}	Output fault detection voltage threshold				V
	Balance off (open load) Balance on (shorted load)	—	0.55	—	
R _{PD_CB}	Output OFF open load detection pull-down resistor Balance off, open load detect disabled	—	2.0	—	kΩ

Symbol	Parameter	Min	Typ	Max	Unit
$I_{OUT(LKG)}$	Output leakage current Balance off, open load detect disabled at $V_{DS} = 4.0\text{ V}$	—	—	1.0	μA
$R_{DS(on)}$	Drain-to-source on resistance $I_{OUT} = 300\text{ mA}$, $T_J = 105\text{ }^\circ\text{C}$ $I_{OUT} = 300\text{ mA}$, $T_J = 25\text{ }^\circ\text{C}$ $I_{OUT} = 300\text{ mA}$, $T_J = -40\text{ }^\circ\text{C}$	— — —	— 0.5 0.4	0.80 — —	Ω
I_{LIM_CB}	Driver current limitation	310	—	950	mA
t_{ON}	Cell balance driver turn on $R_L = 15\ \Omega$	—	350	—	μs
t_{OFF}	Cell balance driver turn off $R_L = 15\ \Omega$	—	200	—	μs
$t_{BAL_DEGLITCH}$	Short/open detect filter time	—	20	—	μs
Internal temperature measurement					
IC_TEMP1_ERR	IC temperature measurement error	-3.0	—	3.0	K
IC_TEMP1_RES	IC temperature resolution	—	0.032	—	K/LSB
TSD_TH	Thermal shutdown	—	170	—	$^\circ\text{C}$
TSD_HYS	Thermal shutdown hysteresis	—	10	—	$^\circ\text{C}$
Default operational parameters					
$V_{CTOV(TH)}$	Cell overvoltage threshold (8 bits), typical value is default value after RESET	0.0	4.2	5.0	V
$V_{CTOV(RES)}$	Cell overvoltage threshold resolution	—	19.53125	—	mV/LSB
$V_{CTUV(TH)}$	Cell undervoltage threshold (8 bits), typical value is default value after RESET	0.0	2.5	5.0	V
$V_{CTUV(RES)}$	Cell undervoltage threshold resolution	—	19.53125	—	mV/LSB
$V_{GPIO_OT(TH)}$	GPIOx configured as ANx input overtemperature threshold after RESET	—	1.16	—	V
$V_{GPIO_OT(RES)}$	Temperature voltage threshold resolution	—	4.8828125	—	mV/LSB
$V_{GPIO_UT(TH)}$	GPIOx configured as ANx input undertemperature threshold after RESET	—	3.82	—	V
$V_{GPIO_UT(RES)}$	Temperature voltage threshold resolution	—	4.8828125	—	mV/LSB
General purpose input/output GPIOx					
V_{IH}	Input high-voltage (3.3 V compatible)	2.0	—	—	V
V_{IL}	Input low-voltage (3.3 V compatible)	—	—	1.0	V
V_{HYS}	Input hysteresis	—	100	—	mV
I_{IL}	Input leakage current Pins tristate, $V_{IN} = V_{COM}$ or AGND	-100	—	100	nA
I_{IDL}	Differential Input Leakage Current GPIO 5,6 GPIO 5,6 configured as digital inputs for current measurement	-30	—	30	nA
V_{OH}	Output high-voltage $I_{OH} = -0.5\text{ mA}$	$V_{COM} - 0.8$	—	—	V
V_{OL}	Output low-voltage $I_{OL} = +0.5\text{ mA}$	—	—	0.8	V
V_{ADC}	Analog ADC input voltage range for ratiometric measurements	AGND	—	V_{COM}	V
$V_{OL(TH)}$	Analog input open pin detect threshold	—	0.15	—	V
R_{OPENPD}	Internal open detection pull-down resistor	—	5.0	—	k Ω
t_{GPIO0_WU}	GPIO0 WU de-glitch filter	—	50	—	μs

Symbol	Parameter	Min	Typ	Max	Unit
t _{GPIO0_FLT}	GPIO0 daisy chain de-glintch filter both edges	—	20	—	µs
t _{GPIO2_SOC}	GPIO2 convert trigger de-glintch filter	—	2.0	—	µs
t _{GPIOx_DIN}	GPIOx configured as digital input de-glintch filter	2.5	—	5.6	µs
Reset input					
V _{IH_RST}	Input high-voltage (3.3 V compatible)	2.0	—	—	V
V _{IL_RST}	Input low-voltage (3.3 V compatible)	—	—	1.0	V
V _{HYS}	Input hysteresis	—	0.6	—	V
t _{RESETFLT}	RESET de-glintch filter	—	100	—	µs
R _{RESET_PD}	Input logic pull down (RESET)	—	100	—	kΩ
SPI_COM_EN input					
V _{IH}	Input high-voltage (3.3 V compatible)	2.0	—	—	V
V _{IL}	Input low-voltage (3.3 V compatible)	—	—	1.0	V
V _{HYS}	Input hysteresis	—	450	—	mV
R _{SPI_COM_EN_PD}	Input pull-down resistor (SPI_COM_EN)	—	100	—	kΩ
Digital interface					
V _{FAULT_HA}	FAULT output (high active, IOH = 1.0 mA)	—	4.9	—	V
I _{FAULT_CL}	FAULT output current limit	3.0	—	40	mA
R _{FAULT_PD}	FAULT output pull-down resistance	—	100	—	kΩ
V _{IH_COMM}	Voltage threshold to detect the input as high SI/RDTX_IN+, SCLK/RDTX_IN-, CSB, SDA, SCL (NOTE: needs to be 3.3 V compatible)	—	—	2.0	V
V _{IL_COMM}	Voltage threshold to detect the input as low SI/RDTX_IN+, SCLK/RDTX_IN-, CSB, SDA, SCL	0.8	—	—	V
V _{HYS}	Input hysteresis SI/RDTX_IN+, SCLK/RDTX_IN-, CSB, SDA, SCL	—	80	—	mV
I _{LOGIC_SS}	Sleep state input logic current CSB	-100	—	100	nA
R _{SCLK_PD}	Input logic pull-down resistance (SCLK/RDTX_IN-, SI/RDTX_IN+)	—	20	—	kΩ
R _{I_PU}	Input logic pull-up resistance to V _{COM} (CSB, SDA, SCL)	—	100	—	kΩ
I _{SO_TRI}	Tristate SO input current 0 V to V _{COM}	-2.0	—	2.0	µA
V _{SO_HIGH}	SO high-state output voltage with I _{SO(HIGH)} = -2.0 mA	V _{COM} - 0.4	—	—	V
V _{SO_LOW}	SO, SDA, SLK low-state output voltage with I _{SO(HIGH)} = -2.0 mA	—	—	0.4	V
CSB _{WU_FLT}	CSB wake-up de-glintch filter, low to high transition	—	—	80	µs
System timing					
t _{CELL_CONV}	Time needed to acquire all 14 cell voltages and the current after an on-demand conversion				µs
	13-bit resolution	—	59	—	
	14-bit resolution	—	80	—	
	15-bit resolution	—	123	—	
	16-bit resolution	—	208	—	

Symbol	Parameter	Min	Typ	Max	Unit
t _{SYNC}	V/I synchronization time				μs
	ADC1-A,B at 13 bit, ADC2 at 13 bit	—	48.16	—	
	ADC1-A,B at 14 bit, ADC2 at 13 bit	—	53.50	—	
	ADC1-A,B at 15 bit, ADC2 at 13 bit	—	64.16	—	
t _{SYNC}	V/I synchronization time				μs
	ADC1-A,B at 13 bit, ADC2 at 14 bit	—	52.14	—	
	ADC1-A,B at 14 bit, ADC2 at 14 bit	—	57.48	—	
	ADC1-A,B at 15 bit, ADC2 at 14 bit	—	68.14	—	
t _{SYNC}	V/I synchronization time				μs
	ADC1-A,B at 13 bit, ADC2 at 15 bit	—	62.12	—	
	ADC1-A,B at 14 bit, ADC2 at 15 bit	—	65.46	—	
	ADC1-A,B at 15 bit, ADC2 at 15 bit	—	76.12	—	
t _{SYNC}	V/I synchronization time				μs
	ADC1-A,B at 13 bit, ADC2 at 16 bit	—	120.51	—	
	ADC1-A,B at 14 bit, ADC2 at 16 bit	—	117.84	—	
	ADC1-A,B at 15 bit, ADC2 at 16 bit	—	112.51	—	
t _{VPWR(READY)}	Time after VPWR connection for the IC to be ready for initialization	—	—	5.0	ms
t _{WAKE-UP}	Power up duration	—	—	440	μs
t _{WAKE_DELAY}	Time between wake pulses	—	600	—	μs
t _{IDLE}	Idle timeout after POR	—	60	—	s
t _{BALANCE}	Cell balance timer range	0.5	—	511	min
t _{CYCLE}	Cyclic acquisition timer range	0.0	—	8.5	s
t _{FAULT}	Fault detection to activation of fault pin Normal mode	—	—	56	μs
t _{EOC}	SOC to data ready (includes post processing of data, ADC_CFG[AVG]=0)	—	148	—	μs
	13-bit resolution	—	201	—	
	14-bit resolution	—	307	—	
	15-bit resolution	—	520	—	
t _{SETTLE}	Time after SOC to begin converting with ADC1-A,B	—	12.28	—	μs
t _{SYS_MEAS1}	Time needed to send an SOC command and read back 96 cell voltages, 48 temperatures, 1 current, and 1 coulomb counter, and ADC1-A,B configured as follows (with ADC_CFG[AVG]=0):				ms
	13-bit resolution	—	4.67	—	
	14-bit resolution	—	4.73	—	
	15-bit resolution	—	4.83	—	
t _{SYS_MEAS2}	Time needed to send an SOC command and read back 96 cell voltages, 1 current, and 1 coulomb counter and ADC1-A,B configured as follows (with ADC_CFG[AVG]=0):				ms
	13-bit resolution	—	3.24	—	
	14-bit resolution	—	3.39	—	
	15-bit resolution	—	3.40	—	
	16-bit resolution	—	3.61	—	

Symbol	Parameter	Min	Typ	Max	Unit
t _{CLST_TPL}	Time needed to send an SOC command and read back 14 cell voltages, 7 temperatures, 1 current, and 1 coulomb counter with TPL communication working at 2.0 Mbps and ADC1-A,B configured as follows (with ADC_CFG[AVG]=0):				ms
	13-bit resolution	—	0.85	—	
	14-bit resolution	—	0.90	—	
	15-bit resolution	—	1.101	—	
	16-bit resolution	—	1.22	—	
t _{CLST_SPI}	Time needed to send an SOC command and read back 14 cell voltages, 7 temperatures, 1 current, and 1 coulomb counter with SPI communication working at 4.0 Mbps and ADC1-A,B configured as follows (with ADC_CFG[AVG]=0):				ms
	13-bit resolution	—	0.57	—	
	14-bit resolution	—	0.64	—	
	15-bit resolution	—	0.76	—	
	16-bit resolution	—	1.03	—	
t _{I2C_DOWNLOAD}	Time to download EEPROM calibration after POR	—	—	1.0	ms
t _{I2C_ACCESS}	EEPROM access time, EEPROM write (depends on device selection)	—	5.0	—	ms
t _{WAVE_DC_BITx}	Daisy chain duty cycle off time t _{WAVE_DC_BITx} = 00	—	500	—	µs
t _{WAVE_DC_BITx}	Daisy chain duty cycle off time t _{WAVE_DC_BITx} = 01	—	1.0	—	ms
t _{WAVE_DC_BITx}	Daisy chain duty cycle off time t _{WAVE_DC_BITx} = 10	—	10	—	ms
t _{WAVE_DC_BITx}	Daisy chain duty cycle off time t _{WAVE_DC_BITx} = 11	—	100	—	ms
t _{WAVE_DC_ON}	Daisy chain duty cycle on time	—	500	—	µs
t _{COM_LOSS}	Time out to reset the IC in the absence of communication	—	1024	—	ms
SPI interface					
t _{SPI_TD}	Sequential data transfer delay in SPI mode (N)	1.0	—	—	µs
F _{SCK}	SCLK/RDTX_IN- frequency	—	—	4.0	MHz
t _{SCK_H}	SCLK/RDTX_IN- high time (A)	125	—	—	ns
t _{SCK_L}	SCLK/RDTX_IN- high time (B)	125	—	—	ns
t _{SCK}	SCLK/RDTX_IN- period (A+B)	250	—	—	ns
t _{FALL}	SCLK/RDTX_IN- falling time	—	—	15	ns
t _{RISE}	SCLK/RDTX_IN- rising time	—	—	15	ns
t _{SET}	SCLK/RDTX_IN- setup time (O)	20	—	—	ns
t _{HOLD}	SCLK/RDTX_IN- hold time (P)	20	—	—	ns
t _{SI_SETUP}	SI/RDTX_IN+ setup time (F)	40	—	—	ns
t _{SI_HOLD}	SI/RDTX_IN+ hold time (G)	40	—	—	ns
t _{SO_VALID}	SO data valid, rising edge of SCLK/RDTX_IN- to SO data valid (I)	—	—	40	ns
t _{SO_EN}	SO enable time (H)	—	—	40	ns
t _{SO_DISABLE}	SO disable time (K)	—	—	40	ns
t _{CSB_LEAD}	CSB lead time (L)	100	—	—	ns
t _{CSB_LAG}	CSB lag time (M)	100	—	—	ns

Symbol	Parameter	Min	Typ	Max	Unit
TPL interface (MCU)					
t _{MCU_RES}	Time between two consecutive message request transmitted by MCU	4.0	—	—	µs
t _{WU_Wait}	Time the MCU shall wait after sending first wake-up message per 33771 IC	0.75	—	—	ms
TPL interface (33771)					
t _{TPL_TD}	Sequential data transfer delay in TPL mode	4.0	—	—	µs
t _{TPL}	Transmit pulse duration	—	210	—	ns
t _{port_delay}	Port delay introduced by each repeater in 33771	—	—	0.95	µs
t _{RES}	Slave response after read command	—	5.0	—	µs
V _{RDTX_INTH}	Differential receiver threshold	—	580	—	mV
t _{EOM}	Message timeout duration	—	250	—	µs

7.5 Timing diagrams

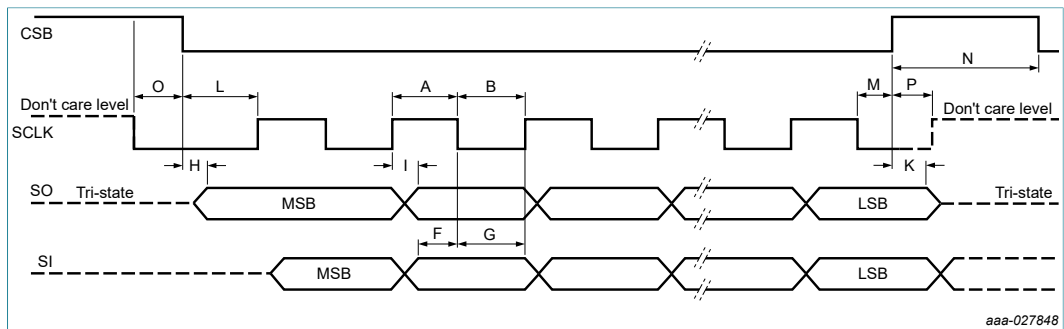

Figure 4. Low-voltage SPI interface timing

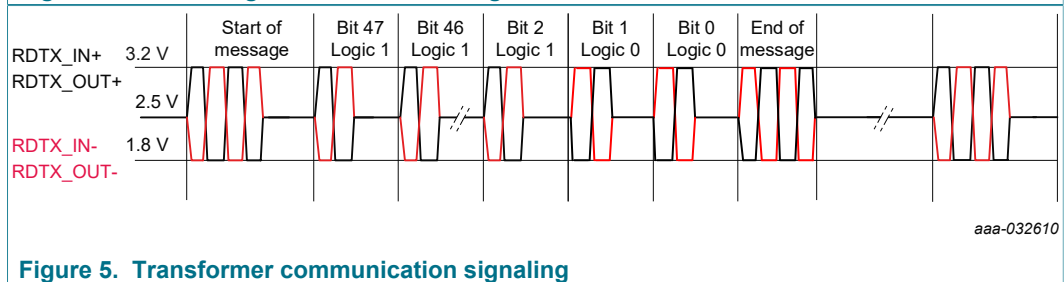

Figure 5. Transformer communication signaling

8 Packaging

8.1 Package mechanical dimensions

Package dimensions are provided in package drawings. To find the most current package outline drawing, go to www.nxp.com and perform a keyword search for the drawing's document number.

Table 9. Package outline

Package	Suffix	Package outline drawing number
64-pin LQFP-EP	AE	98ASA10763D

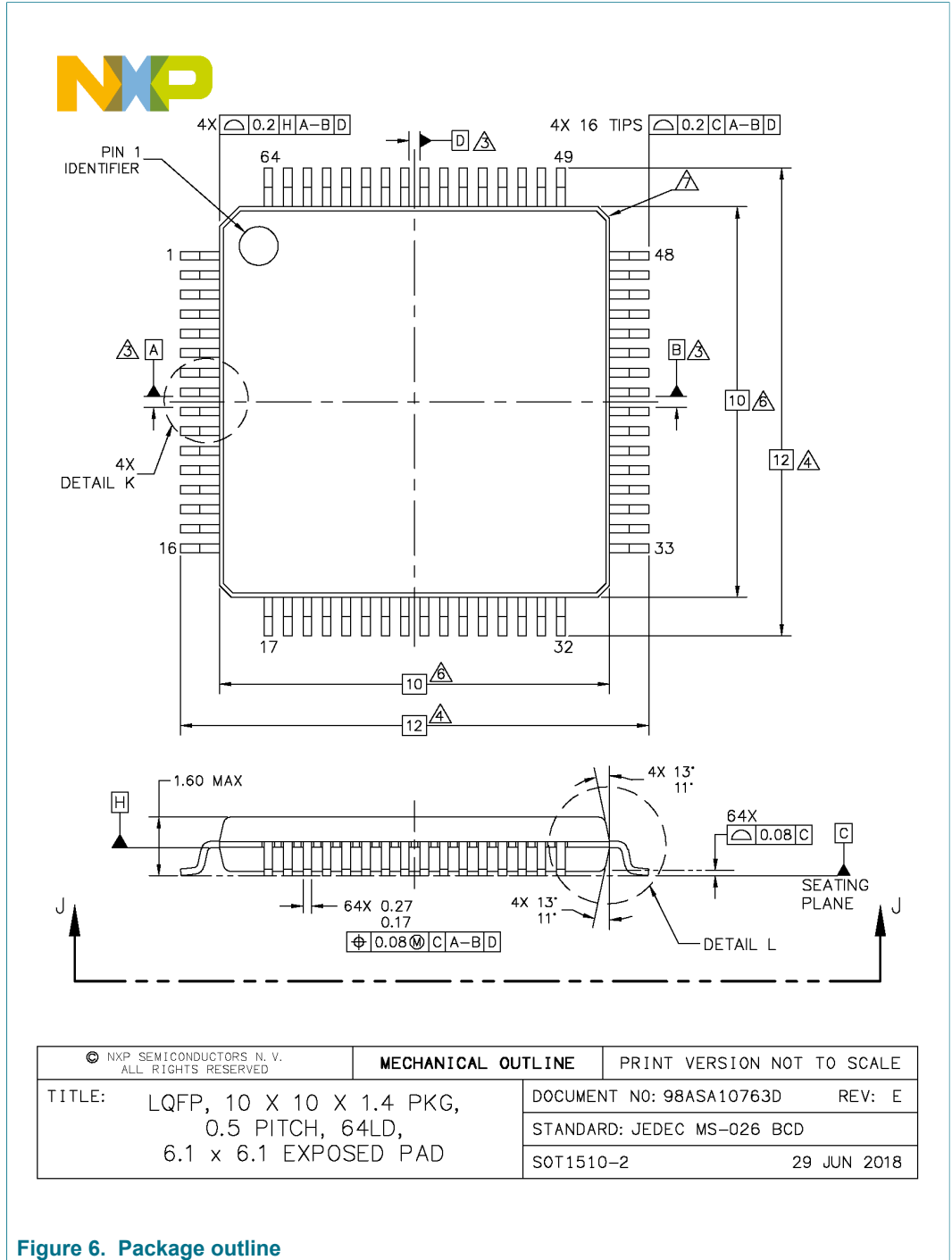
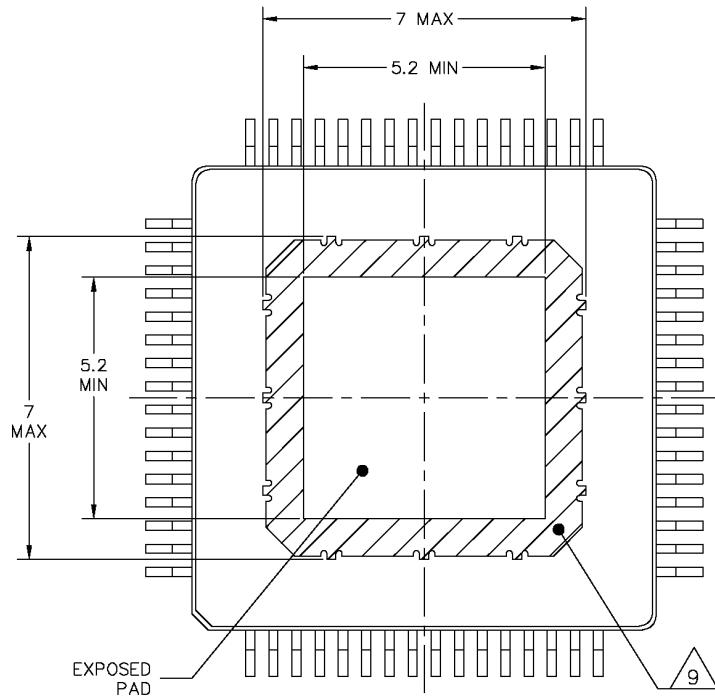

Figure 6. Package outline



VIEW J—J

© NXP SEMICONDUCTORS N. V. ALL RIGHTS RESERVED	MECHANICAL OUTLINE	PRINT VERSION NOT TO SCALE	
TITLE: LQFP, 10 X 10 X 1.4 PKG, 0.5 PITCH, 64LD, 6.1 x 6.1 EXPOSED PAD	DOCUMENT NO: 98ASA10763D	REV: E	
	STANDARD: JEDEC MS-026 BCD		
	SOT1510-2	29 JUN 2018	

Figure 7. Package outline

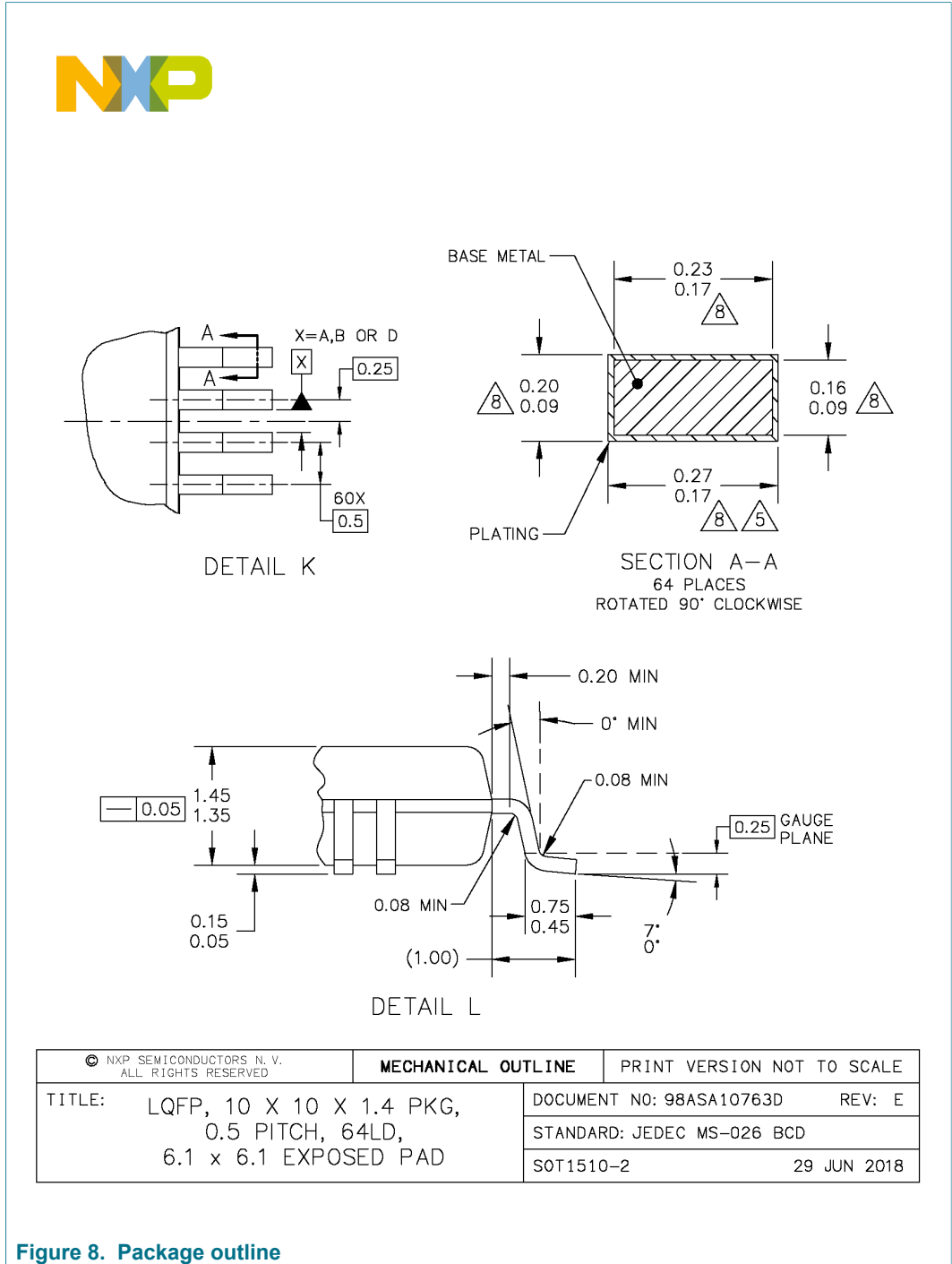

Figure 8. Package outline

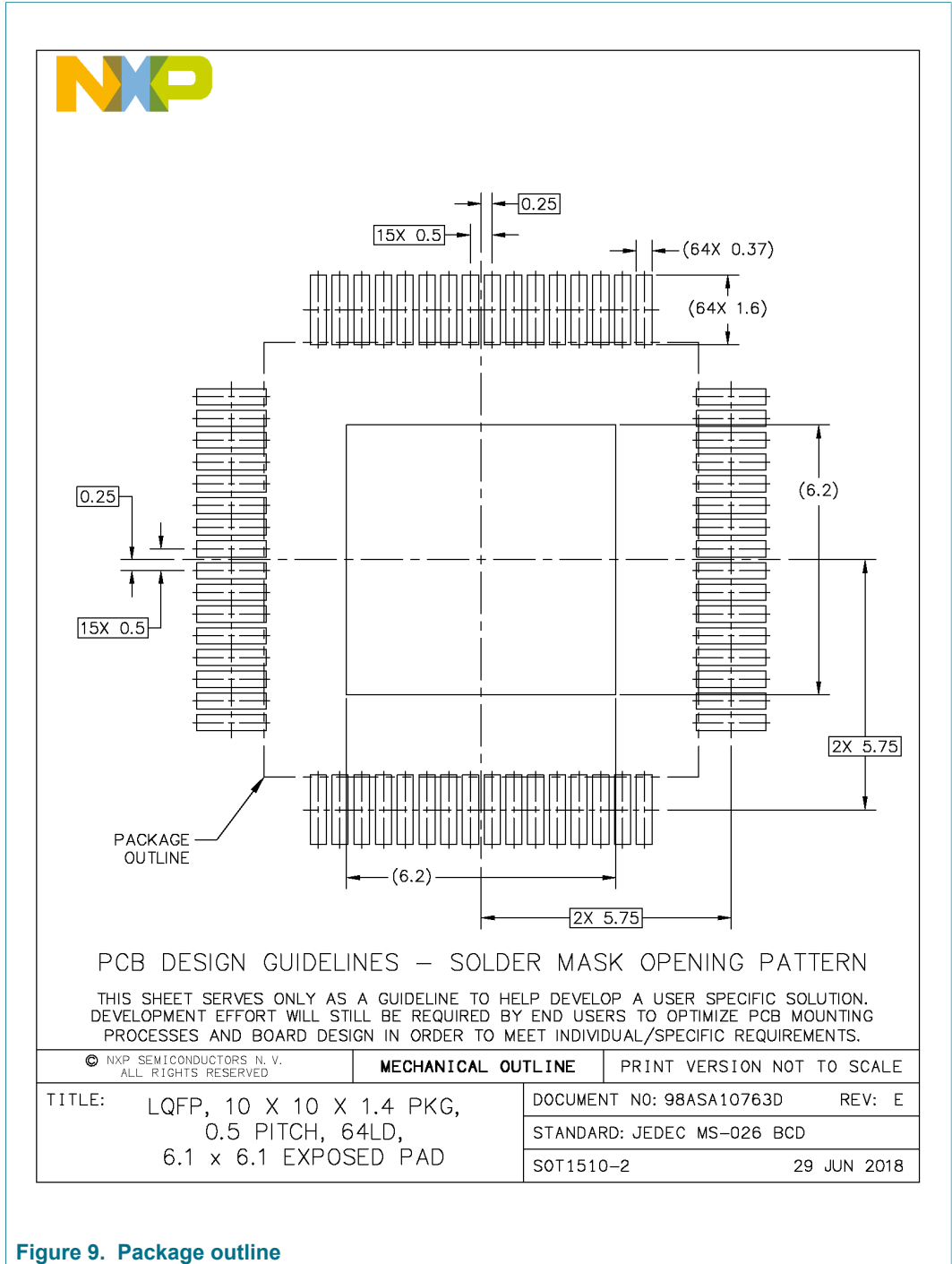

Figure 9. Package outline

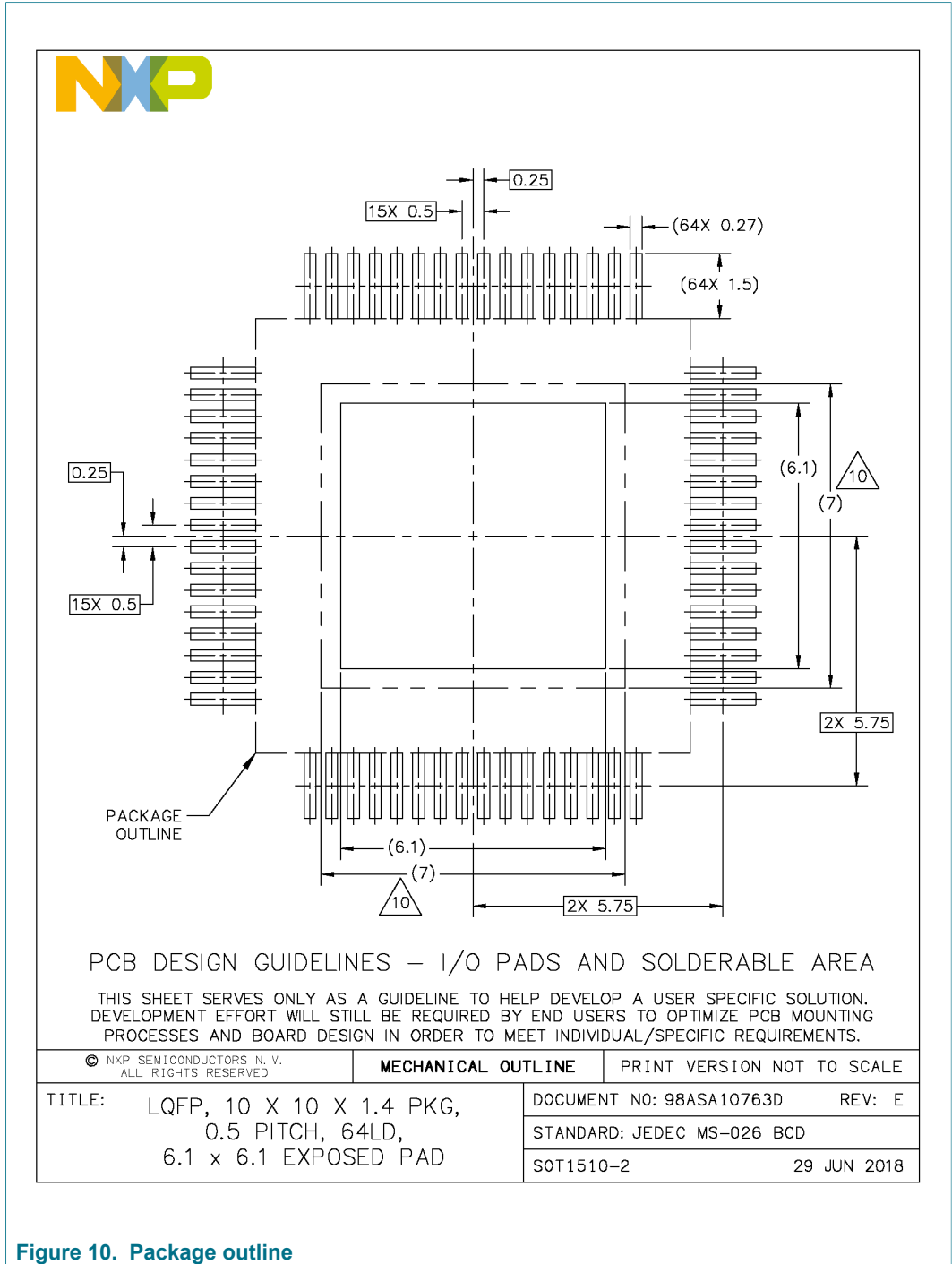

Figure 10. Package outline

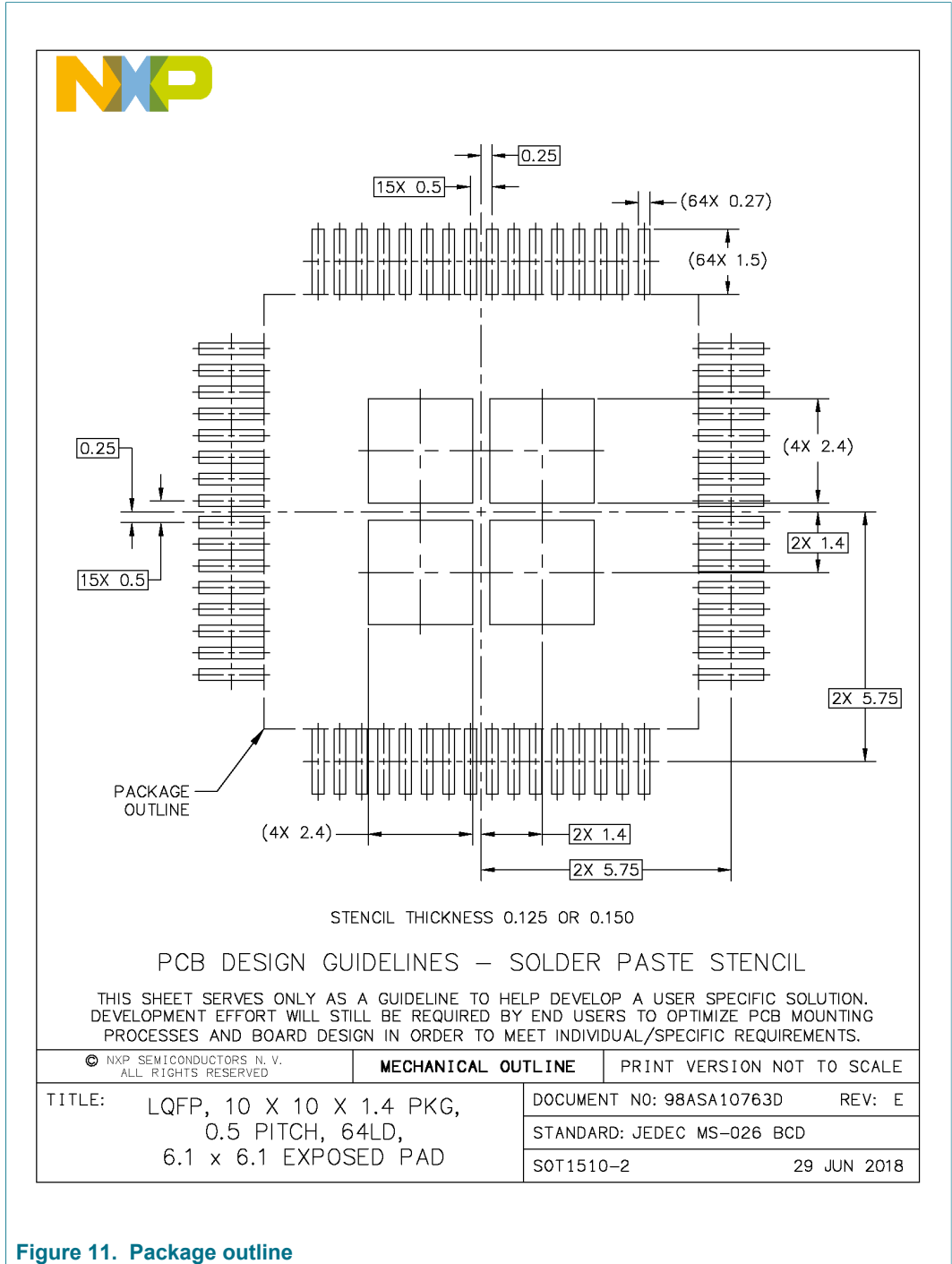

Figure 11. Package outline



NOTES:

1. DIMENSIONS ARE IN MILLIMETERS.
2. INTERPRET DIMENSIONS AND TOLERANCES PER ASME Y14.5M-1994.
3. DATUMS A, B AND D TO BE DETERMINED AT DATUM PLANE H.
4. DIMENSIONS TO BE DETERMINED AT SEATING PLANE C.
5. DIMENSION DOES NOT INCLUDE DAMBAR PROTRUSION. ALLOWABLE DAMBAR PROTRUSION SHALL NOT CAUSE THE LEAD WIDTH TO EXCEED THE MAXIMUM DIMENSION BY MORE THAN 0.08 MM. DAMBAR CANNOT BE LOCATED ON THE LOWER RADIUS OR THE FOOT. MINIMUM SPACE BETWEEN PROTRUSION AND ADJACENT LEAD OR PROTRUSION 0.07 MM.
6. DIMENSIONS DO NOT INCLUDE MOLD PROTRUSION. ALLOWABLE PROTRUSION IS 0.25 MM PER SIDE. DIMENSIONS ARE MAXIMUM PLASTIC BODY SIZE DIMENSIONS INCLUDING MOLD MISMATCH.
7. EXACT SHAPE OF EACH CORNER IS OPTIONAL.
8. THESE DIMENSIONS APPLY TO THE FLAT SECTION OF THE LEAD BETWEEN 0.10 MM AND 0.25 MM FROM THE LEAD TIP.
9. HATCHED AREA REPRESENTS POSSIBLE MOLD FLASH ON EXPOSED PAD.
10. KEEP OUT ZONE REPRESENTS AREA ON PCB THAT MUST NOT HAVE ANY EXPOSED METAL (EG. TRACE/VIA) FOR PCB ROUTING DUE TO THE POSSIBILITY OF SHORTING TO TIE BAR/EXPOSED PAD.

© NXP SEMICONDUCTORS N.V. ALL RIGHTS RESERVED	MECHANICAL OUTLINE	PRINT VERSION NOT TO SCALE	
TITLE: LQFP, 10 X 10 X 1.4 PKG, 0.5 PITCH, 64LD, 6.1 x 6.1 EXPOSED PAD	DOCUMENT NO: 98ASA10763D		REV: E
	STANDARD: JEDEC MS-026 BCD		
	SOT1510-2		29 JUN 2018

Figure 12. Package outline

9 References

Following are URLs where you can obtain information on related NXP products and application solutions:

- [1] **Product summary page for RD33771CNTREVM: HV Battery management system reference design** — <http://www.nxp.com/products/RD33771CNTREVM>
- [2] **Product summary page for MC33664: Isolated Network High-Speed Transceiver** — <http://www.nxp.com/products/MC33664>
- [3] **Product summary page for MC33771: 14-Channel Li-ion Battery Cell Controller IC** — <http://www.nxp.com/products/MC33771C>
- [4] **Product summary page for UJA1169: Mini high-speed CAN companion system basis chip** — <https://www.nxp.com/products/power-management/system-basis-chips/mini-system-basis-chips-sbcs/mini-high-speed-can-companion-system-basis-chip:UJA1169LTK>
- [5] **Product summary page for S32K144: 32-bit Automotive General Purpose Microcontroller** — <https://www.nxp.com/products/processors-and-microcontrollers/arm-microcontrollers/s32k-32-bit-automotive-general-purpose-microcontrollers:S32K>
- [6] **Support page for S32DS-PA: S32DS-ARM: S32 Design Studio for Arm** — <https://www.nxp.com/design/software/development-software/s32-design-studio-ide/s32-design-studio-for-arm:S32DS-ARM>
- [7] **NXP DocStore** — docstore.nxp.com

10 Legal information

10.1 Definitions

Draft — The document is a draft version only. The content is still under internal review and subject to formal approval, which may result in modifications or additions. NXP Semiconductors does not give any representations or warranties as to the accuracy or completeness of information included herein and shall have no liability for the consequences of use of such information.

10.2 Disclaimers

Limited warranty and liability — Information in this document is believed to be accurate and reliable. However, NXP Semiconductors does not give any representations or warranties, expressed or implied, as to the accuracy or completeness of such information and shall have no liability for the consequences of use of such information. NXP Semiconductors takes no responsibility for the content in this document if provided by an information source outside of NXP Semiconductors. In no event shall NXP Semiconductors be liable for any indirect, incidental, punitive, special or consequential damages (including - without limitation - lost profits, lost savings, business interruption, costs related to the removal or replacement of any products or rework charges) whether or not such damages are based on tort (including negligence), warranty, breach of contract or any other legal theory. Notwithstanding any damages that customer might incur for any reason whatsoever, NXP Semiconductors' aggregate and cumulative liability towards customer for the products described herein shall be limited in accordance with the Terms and conditions of commercial sale of NXP Semiconductors.

Right to make changes — NXP Semiconductors reserves the right to make changes to information published in this document, including without limitation specifications and product descriptions, at any time and without notice. This document supersedes and replaces all information supplied prior to the publication hereof.

Applications — Applications that are described herein for any of these products are for illustrative purposes only. NXP Semiconductors makes no representation or warranty that such applications will be suitable for the specified use without further testing or modification. Customers are responsible for the design and operation of their applications and products using NXP Semiconductors products, and NXP Semiconductors accepts no liability for any assistance with applications or customer product design. It is customer's sole responsibility to determine whether the NXP Semiconductors product is suitable and fit for the customer's applications and products planned, as well as for the planned application and use of customer's third party customer(s). Customers should provide appropriate design and operating safeguards to minimize the risks associated with their applications and products. NXP Semiconductors does not accept any liability related to any default, damage, costs or problem which is based on any weakness or default in the customer's applications or products, or

the application or use by customer's third party customer(s). Customer is responsible for doing all necessary testing for the customer's applications and products using NXP Semiconductors products in order to avoid a default of the applications and the products or of the application or use by customer's third party customer(s). NXP does not accept any liability in this respect.

Limiting values — Stress above one or more limiting values (as defined in the Absolute Maximum Ratings System of IEC 60134) will cause permanent damage to the device. Limiting values are stress ratings only and (proper) operation of the device at these or any other conditions above those given in the Recommended operating conditions section (if present) or the Characteristics sections of this document is not warranted. Constant or repeated exposure to limiting values will permanently and irreversibly affect the quality and reliability of the device.

Terms and conditions of commercial sale — NXP Semiconductors products are sold subject to the general terms and conditions of commercial sale, as published at <http://www.nxp.com/profile/terms>, unless otherwise agreed in a valid written individual agreement. In case an individual agreement is concluded only the terms and conditions of the respective agreement shall apply. NXP Semiconductors hereby expressly objects to applying the customer's general terms and conditions with regard to the purchase of NXP Semiconductors products by customer.

Suitability for use in automotive applications — This NXP Semiconductors product has been qualified for use in automotive applications. Unless otherwise agreed in writing, the product is not designed, authorized or warranted to be suitable for use in life support, life-critical or safety-critical systems or equipment, nor in applications where failure or malfunction of an NXP Semiconductors product can reasonably be expected to result in personal injury, death or severe property or environmental damage. NXP Semiconductors and its suppliers accept no liability for inclusion and/or use of NXP Semiconductors products in such equipment or applications and therefore such inclusion and/or use is at the customer's own risk.

Export control — This document as well as the item(s) described herein may be subject to export control regulations. Export might require a prior authorization from competent authorities.

Translations — A non-English (translated) version of a document is for reference only. The English version shall prevail in case of any discrepancy between the translated and English versions.

10.3 Trademarks

Notice: All referenced brands, product names, service names and trademarks are the property of their respective owners.

NXP — is a trademark of NXP B.V.

SMARTMOS — is a trademark of NXP B.V.

Tables

Tab. 1.	Part number breakdown	4	Tab. 6.	Maximum ratings	9
Tab. 2.	Advanced orderable part table	5	Tab. 7.	Thermal ratings	11
Tab. 3.	Premium orderable part table	5	Tab. 8.	Static and dynamic electrical characteristics ...	11
Tab. 4.	Pin definitions	6	Tab. 9.	Package outline	19
Tab. 5.	Ratings vs. operating requirements	9			

Figures

Fig. 1.	Simplified application diagram, SPI use case	2	Fig. 7.	Package outline	21
Fig. 2.	Simplified application diagram, TPL use case	3	Fig. 8.	Package outline	22
Fig. 3.	Pinout diagram	6	Fig. 9.	Package outline	23
Fig. 4.	Low-voltage SPI interface timing	19	Fig. 10.	Package outline	24
Fig. 5.	Transformer communication signaling	19	Fig. 11.	Package outline	25
Fig. 6.	Package outline	20	Fig. 12.	Package outline	26

Contents

1	General description	1
2	Features	1
3	Simplified application diagram	2
4	Applications	3
5	Ordering information	4
5.1	Part numbers definition	4
5.2	Part numbers list	5
6	Pinning information	6
6.1	Pinout diagram	6
6.2	Pin definitions	6
7	General product characteristics	9
7.1	Ratings and operating requirements relationship	9
7.2	Maximum ratings	9
7.3	Thermal characteristics	11
7.4	Electrical characteristics	11
7.5	Timing diagrams	19
8	Packaging	19
8.1	Package mechanical dimensions	19
9	References	27
10	Legal information	28

Please be aware that important notices concerning this document and the product(s) described herein, have been included in section 'Legal information'.

© NXP B.V. 2020.

All rights reserved.

For more information, please visit: <http://www.nxp.com>

For sales office addresses, please send an email to: salesaddresses@nxp.com

Date of release: 20 January 2020
Document identifier: PB_MC33771C

Mouser Electronics

Authorized Distributor

Click to View Pricing, Inventory, Delivery & Lifecycle Information:

[NXP:](#)

[MC33771CTA1AE](#) [MC33771CTA1AER2](#) [MC33771CTA2AE](#) [MC33771CTA2AER2](#) [MC33771CTP1AE](#)
[MC33771CTP1AER2](#) [MC33771CTP2AE](#) [MC33771CTP2AER2](#)

Looking for pricing, stock, or lifecycle information?

Click below to explore more details on WIN SOURCE:

- ⊖ [View MC33771CTA1AER2 on WIN SOURCE](#)
- ⊖ [NXP / Nexperia Information](#)

Optimize Your Supply Chain with WIN SOURCE Solutions

- ✓ Global Sourcing Solution
- ✓ Obsolete Management
- ✓ Cost Control Management
- ✓ Shortage Management
- ✓ Alternative Solution
- ✓ Excess Inventory Management