



**THE DATASHEET OF
SN74LXC1T14QDCKRQ1**



SN74LXC1T14-Q1 Automotive Dual-Supply Inverting Translator with Schmitt-Trigger Input

1 Features

- AEC-Q100 qualified for automotive applications
- Fully configurable dual-rail design allows each port to operate from 1.1 V to 5.5 V
- Robust, glitch-free power supply sequencing
- Up to 420-Mbps support for 3.3 V to 5.0 V
- Schmitt-trigger inputs allow for slow or noisy inputs
- [Input with integrated dynamic pull-down resistors](#) help reduce external component count
- High drive strength (up to 32 mA at 5 V)
- Low power consumption
 - 3- μ A maximum (25°C)
 - 6- μ A maximum (–40°C to 125°C)
- [V_{CC} isolation and V_{CC} disconnect \(I_{off-float}\)](#) feature
 - If either V_{CC} supply is < 100 mV or disconnected, all I/O's get pulled-down and then become high-impedance
- Overvoltage tolerant inputs accept voltages up to 5.5 V regardless of supply voltage.
- I_{off} supports partial-power-down mode operation
- Operating temperature from –40°C to +125°C
- Latch-up performance exceeds 100 mA per JESD 78, class II
- ESD protection exceeds JESD 22
 - 4000-V human-body model
 - 1000-V charged-device model

2 Applications

- [Eliminate slow or noisy input signals](#)
- [Driving indicator LEDs or buzzers](#)
- [Debouncing a mechanical switch](#)
- General purpose I/O (GPIO) level shifting

3 Description

The SN74LXC1T14-Q1 is a single bit, dual-supply inverting voltage level translation device with Schmitt-trigger input. The input pin A is referenced to V_{CCI} logic levels, and output pin Y is referenced to V_{CCO} logic levels. The input pin A is able to accept voltages ranging from 1.1 V to 5.5 V and can be connected directly to V_{CCI} or GND. See [Device Functional Modes](#) for a summary of the operation of the logic.

This device ensures low power consumption and is fully specified for partial-power-down applications using I_{off}. The I_{off} circuitry disables the outputs when the device is powered down. This inhibits current backflow into the device which prevents damage to the device.

Package Information (1)

PART NUMBER	PACKAGE	BODY SIZE (NOM)
SN74LXC1T14-Q1	SC70 (5) (DCK)	2.00 mm × 1.25 mm

(1) For all available packages, see the orderable addendum at the end of the data sheet.

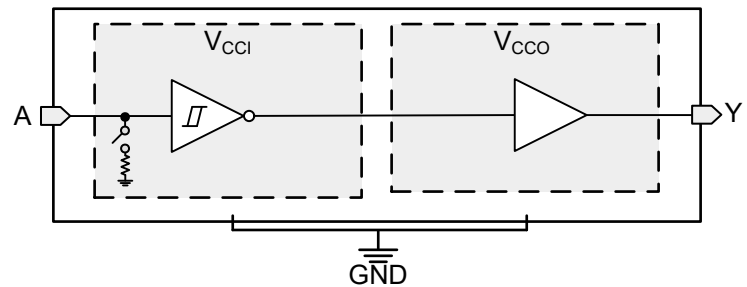

Simplified Diagram



Table of Contents

1 Features	1	8.3 Feature Description.....	12
2 Applications	1	8.4 Device Functional Modes.....	15
3 Description	1	9 Application and Implementation	16
4 Revision History	2	9.1 Application Information.....	16
5 Pin Configuration and Functions	3	9.2 Typical Application.....	16
6 Specifications	4	10 Power Supply Recommendations	17
6.1 Absolute Maximum Ratings.....	4	11 Layout	17
6.2 ESD Ratings.....	4	11.1 Layout Guidelines.....	17
6.3 Recommended Operating Conditions.....	5	11.2 Layout Example.....	17
6.4 Thermal Information.....	5	12 Device and Documentation Support	18
6.5 Electrical Characteristics.....	6	12.1 Device Support.....	18
6.6 Switching Characteristics: Tpd.....	8	12.2 Documentation Support.....	18
6.7 Switching Characteristics: T _{MAX}	9	12.3 Receiving Notification of Documentation Updates..	18
6.8 Typical Characteristics.....	10	12.4 Support Resources.....	18
7 Parameter Measurement Information	11	12.5 Trademarks.....	18
7.1 Load Circuit and Voltage Waveforms.....	11	12.6 Electrostatic Discharge Caution.....	18
8 Detailed Description	12	12.7 Glossary.....	18
8.1 Overview.....	12	13 Mechanical, Packaging, and Orderable	
8.2 Functional Block Diagram.....	12	Information	18

4 Revision History

DATE	REVISION	NOTES
August 2022	*	Initial Release

5 Pin Configuration and Functions

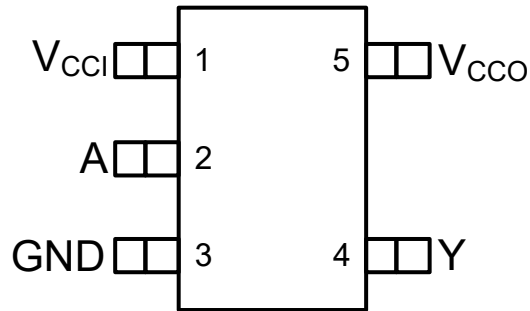

Figure 5-1. DCK Package, 5-Pin SC70 (Top View)

Table 5-1. Pin Functions

PIN		TYPE ⁽¹⁾	DESCRIPTION
NAME	DCK		
V _{CCI}	1	—	Input supply voltage. $1.1\text{ V} \leq V_{CCI} \leq 5.5\text{ V}$.
A	2	I	Input A. Referenced to V _{CCI} .
GND	3	—	Ground.
Y	4	O	Output Y. Referenced to V _{CCO} .
V _{CCO}	5	—	Output supply voltage. $1.1\text{ V} \leq V_{CCO} \leq 5.5\text{ V}$.

(1) I = input, O = output

6 Specifications

6.1 Absolute Maximum Ratings

over operating free-air temperature range (unless otherwise noted)⁽¹⁾

		MIN	MAX	UNIT
V _{CCI}	Input supply voltage A	-0.5	6.5	V
V _{CCO}	Output supply voltage Y	-0.5	6.5	V
V _I	Input Voltage ⁽²⁾	-0.5	6.5	V
V _O	Voltage applied to any output in the high-impedance or power-off state ⁽²⁾	-0.5	6.5	V
V _O	Voltage applied to any output in the high or low state ^{(2) (3)}	-0.5	V _{CCB} + 0.5	V
I _{IK}	Input clamp current	V _I < 0	-50	mA
I _{OK}	Output clamp current	V _O < 0	-50	mA
I _O	Continuous output current	-50	50	mA
	Continuous current through V _{CC} or GND	-200	200	mA
T _j	Junction Temperature		150	°C
T _{stg}	Storage temperature	-65	150	°C

- (1) Operation outside the *Absolute Maximum Ratings* may cause permanent device damage. *Absolute Maximum Ratings* do not imply functional operation of the device at these or any other conditions beyond those listed under *Recommended Operating Conditions*. If used outside the *Recommended Operating Conditions* but within the *Absolute Maximum Ratings*, the device may not be fully functional, and this may affect device reliability, functionality, performance, and shorten the device lifetime.
- (2) The input voltage and output negative-voltage ratings may be exceeded if the input and output current ratings are observed.
- (3) The output positive-voltage rating may be exceeded up to 6.5 V maximum if the output current rating is observed.

6.2 ESD Ratings

		VALUE	UNIT
V _(ESD)	Electrostatic discharge	Human body model (HBM), per AEC Q100-002 ⁽¹⁾	V
		Charged device model (CDM), per AEC Q100-011	

- (1) AEC Q100-002 indicates that HBM stressing shall be in accordance with the ANSI/ESDA/JEDEC JS-001 specification

6.3 Recommended Operating Conditions

over operating free-air temperature range (unless otherwise noted) ⁽¹⁾ ⁽²⁾ ⁽³⁾

		MIN	MAX	UNIT	
V _{CCI}	Input supply voltage	1.1	5.5	V	
V _{CCO}	Output Supply voltage	1.1	5.5	V	
I _{OH}	High-level output current	V _{CCO} = 1.1 V	-0.1	mA	
		V _{CCO} = 1.4 V	-4		
		V _{CCO} = 1.65 V	-8		
		V _{CCO} = 2.3 V	-12		
		V _{CCO} = 3 V	-24		
		V _{CCO} = 4.5 V	-32		
I _{OL}	Low-level output current	V _{CCO} = 1.1 V	0.1	mA	
		V _{CCO} = 1.4 V	4		
		V _{CCO} = 1.65 V	8		
		V _{CCO} = 2.3 V	12		
		V _{CCO} = 3 V	24		
		V _{CCO} = 4.5 V	32		
V _I	Input voltage ⁽³⁾	0	5.5	V	
V _O	Output voltage	Active State	0	V _{CCO}	V
		Tri-State	0	5.5	
T _A	Operating free-air temperature	-40	125	°C	

- (1) V_{CCI} is the V_{CC} associated with the input port.
(2) V_{CCO} is the V_{CC} associated with the output port.
(3) Input of this device has a weak pulldown to ensure the line is not floating when undefined external to the device. The input leakage from these weak pulldowns is defined by the I_I specification indicated under [Electrical Characteristics](#).

6.4 Thermal Information

THERMAL METRIC ⁽¹⁾		SN74LXC1T14	UNIT
		DCK (SC70)	
		5 PINS	
R _{θJA}	Junction-to-ambient thermal resistance	222.9	°C/W
R _{θJC(top)}	Junction-to-case (top) thermal resistance	132.9	°C/W
R _{θJB}	Junction-to-board thermal resistance	109.5	°C/W
Y _{JT}	Junction-to-top characterization parameter	48.4	°C/W
Y _{JB}	Junction-to-board characterization parameter	108.9	°C/W
R _{θJC(bottom)}	Junction-to-case (bottom) thermal resistance	N/A	°C/W

- (1) For more information about traditional and new thermal metrics, see the [Semiconductor and IC Package Thermal Metrics](#) application report.

6.5 Electrical Characteristics

over operating free-air temperature range (unless otherwise noted)^{(1) (2)}

PARAMETER	TEST CONDITIONS	V _{CCI}	V _{CCO}	Operating free-air temperature (T _A)						UNIT	
				25°C			-40°C to 85°C		-40°C to 125°C		
				MIN	TYP	MAX	MIN	TYP	MAX		MIN
V _{T+}	Positive-going input-threshold voltage	Data Input (Referenced to V _{CCI})	1.1 V	1.1 V			0.44	0.88	0.44	0.88	V
			1.4 V	1.4 V			0.60	0.98	0.60	0.98	
			1.65 V	1.65 V			0.76	1.13	0.76	1.13	
			2.3 V	2.3 V			1.08	1.56	1.08	1.56	
			3 V	3 V			1.48	1.92	1.48	1.92	
			4.5 V	4.5 V			2.19	2.74	2.19	2.74	
			5.5 V	5.5 V			2.65	3.33	2.65	3.33	
V _{T-}	Negative-going input-threshold voltage	Data Input (Referenced to V _{CCI})	1.1 V	1.1 V			0.17	0.48	0.17	0.48	V
			1.4 V	1.4 V			0.28	0.59	0.28	0.59	
			1.65 V	1.65 V			0.35	0.69	0.35	0.69	
			2.3 V	2.3 V			0.56	0.97	0.56	0.97	
			3 V	3 V			0.89	1.5	0.89	1.5	
			4.5 V	4.5 V			1.51	1.97	1.51	1.97	
			5.5 V	5.5 V			1.88	2.4	1.88	2.4	
ΔV _T	Input-threshold hysteresis (V _{T+} - V _{T-})	Data Input (A) (Referenced to V _{CCI})	1.1 V	1.1 V			0.2	0.4	0.2	0.4	V
			1.4 V	1.4 V			0.25	0.5	0.25	0.5	
			1.65 V	1.65 V			0.3	0.55	0.3	0.55	
			2.3 V	2.3 V			0.38	0.65	0.38	0.65	
			3 V	3 V			0.46	0.72	0.46	0.72	
			4.5 V	4.5 V			0.58	0.93	0.58	0.93	
			5.5 V	5.5 V			0.69	1.06	0.69	1.06	
V _{OH}	High-level output voltage ⁽³⁾	I _{OH} = -100 μA	1.1 V - 5.5 V	1.1 V - 5.5 V			V _{CCO} - 0.1	V _{CCO} - 0.1			V
		I _{OH} = -4 mA	1.4 V	1.4 V			1	1			
		I _{OH} = -8 mA	1.65 V	1.65 V			1.2	1.2			
		I _{OH} = -12 mA	2.3 V	2.3 V			1.9	1.9			
		I _{OH} = -24 mA	3 V	3 V			2.4	2.4			
		I _{OH} = -32 mA	4.5 V	4.5 V			3.8	3.8			
V _{OL}	Low-level output voltage ⁽⁴⁾	I _{OL} = 100 μA	1.1 V - 5.5 V	1.1 V - 5.5 V				0.1		0.1	V
		I _{OL} = 4 mA	1.4 V	1.4 V				0.3		0.3	
		I _{OL} = 8 mA	1.65 V	1.65 V				0.45		0.45	
		I _{OL} = 12 mA	2.3 V	2.3 V				0.3		0.3	
		I _{OL} = 24 mA	3 V	3 V				0.55		0.55	
		I _{OL} = 32 mA	4.5 V	4.5 V				0.55		0.55	
I _I	Input leakage current	Data Input ⁽⁵⁾ V _I = V _{CCI} or GND	1.1 V - 5.5 V	1.1 V - 5.5 V	-0.3	1	-1	1	-2	2	μA
I _{off}	Partial power down current	Inputs V _I or V _O = 0 V - 5.5 V	0 V	0 V - 5.5 V	-1	1	-2	2	-2.5	2.5	μA
			0 V - 5.5 V	0 V	-1	1	-2	2	-2.5	2.5	
I _{off-float}	Floating supply Partial power down current	Inputs V _I or V _O = GND	Floating ⁽⁶⁾	0 V - 5.5 V	-1.5	1.5	-2	2	-2.5	2.5	μA
			0 V - 5.5 V	Floating ⁽⁶⁾	-1.5	1.5	-2	2	-2.5	2.5	

6.5 Electrical Characteristics (continued)

over operating free-air temperature range (unless otherwise noted)^{(1) (2)}

PARAMETER	TEST CONDITIONS	V _{CCI}	V _{CCO}	Operating free-air temperature (T _A)									UNIT	
				25°C			–40°C to 85°C			–40°C to 125°C				
				MIN	TYP	MAX	MIN	TYP	MAX	MIN	TYP	MAX		
I _{CCI}	V _{CCI} supply current	V _I = V _{CCI} or GND I _O = 0	1.1 V – 5.5 V	1.1 V – 5.5 V	2			3			6			μA
			0 V	5.5 V	–0.2			–0.5			–1			
			5.5 V	0 V	1			2			4			
		V _I = GND I _O = 0	5.5 V	Floating ⁽⁶⁾	2			3			6			
I _{CCO}	V _{CCO} supply current	V _I = V _{CCI} or GND I _O = 0	1.1 V – 5.5 V	1.1 V – 5.5 V	2			3			6			μA
			0 V	5.5 V	1			2			4			
			5.5 V	0 V	–0.2			–0.5			–1			
I _{CCO}		V _I = GND I _O = 0	Floating ⁽⁶⁾	5.5 V	2			3			6			
I _{CCI} + I _{CCO}	Combined supply current	V _I = V _{CCI} or GND I _O = 0	1.1 V – 5.5 V	1.1 V – 5.5 V	3			4			6			μA
ΔI _{CCI}	Additional input supply current	V _I = V _{CCI} – 0.6 V	3.0 V – 5.5 V	3.0 V – 5.5 V				50			75			μA
C _i	Input Capacitance	V _I = 3.3 V or GND	3.3 V	3.3 V	5			10			10			pF
C _o	Output Capacitance	V _{CCO} = 0V V _O = 1.65 V DC +1 MHz -16 dBm sine wave	3.3 V	3.3 V	5			10			10			pF

- (1) V_{CCI} is the V_{CC} associated with the input port.
- (2) V_{CCO} is the V_{CC} associated with the output port.
- (3) Tested at V_I = V_{T+(MAX)}.
- (4) Tested at V_I = V_{T-(MIN)}.
- (5) For I/O ports, the parameter I_I includes the I_{OZ} current.
- (6) Floating is defined as a node that is both not actively driven by an external device and has leakage not exceeding 10 nA.

6.6 Switching Characteristics: Tpd

Over operating free-air temperature range (T_A). See [Figure 7-1](#) and [Table 7-1](#) for test circuit and loading. See [Figure 7-2](#) and [Figure 7-3](#) for measurement waveforms.

PARAMETER	FROM	TO	Output Supply Voltage (V_{CCO})	Input Supply Voltage (V_{CCI})												UNIT						
				1.2 ± 0.1 V			1.5 ± 0.1 V			1.8 ± 0.15 V			2.5 ± 0.2 V				3.3 ± 0.3 V			5.0 ± 0.5 V		
				MIN	TYP	MAX	MIN	TYP	MAX	MIN	TYP	MAX	MIN	TYP	MAX		MIN	TYP	MAX	MIN	TYP	MAX
t_{pd}	Propagation delay	A	Y	1.2 ± 0.1 V	10	83	10	70	10	66	9	59	9	58	9	54	ns					
				1.5 ± 0.1 V	9	36	8	28	7	26	7	22	7	21	7	20						
				1.8 ± 0.15 V	8	32	7	23	6	21	6	18	6	17	6	16						
				2.5 ± 0.2 V	7	29	6	18	5	15	5	13	4	12	4	11						
				3.3 ± 0.3 V	7	29	6	16	4	13	4	11	3	10	3	9						
				5.0 ± 0.5 V	7	28	5	15	4	12	3	10	2	9	2	8						

6.7 Switching Characteristics: T_{MAX}

over operating free-air temperature range (unless otherwise noted)

PARAMETER	TEST CONDITIONS		V _{CC1}	V _{CC0}	Operating free-air temperature (T _A)			UNIT
					-40°C to 125°C			
					MIN	TYP	MAX	
T _{MAX} - Maximum Data Rate	50% Duty Cycle Input One channel switching 20% of pulse > 0.7*V _{CC0} 20% of pulse < 0.3*V _{CC0}	Up Translation	3.0 V - 3.6 V	4.5 V - 5.5 V	200	420	Mbps	
			2.25 V - 2.75 V	4.5 V - 5.5 V	150	300		
			1.65 V - 1.95 V	4.5 V - 5.5 V	100	200		
			1.1 V - 1.3 V	4.5 V - 5.5 V	20	40		
			1.65 V - 1.95 V	3.0 V - 3.6 V	100	210		
			1.1 V - 1.3 V	3.0 V - 3.6 V	10	20		
		Down Translation	1.1 V - 1.3 V	1.65 V - 1.95 V	5	10		
			4.5 V - 5.5 V	3.0 V - 3.6 V	100	210		
			4.5 V - 5.5 V	2.25 V - 2.75 V	75	140		
			4.5 V - 5.5 V	1.65 V - 1.95 V	50	75		
			4.5 V - 5.5 V	1.1 V - 1.3 V	15	30		
			3.0 V - 3.6 V	1.65 V - 1.95 V	40	75		
			3.0 V - 3.6 V	1.1 V - 1.3 V	10	20		
			1.65 V - 1.95 V	1.1 V - 1.3 V	5	10		

6.8 Typical Characteristics

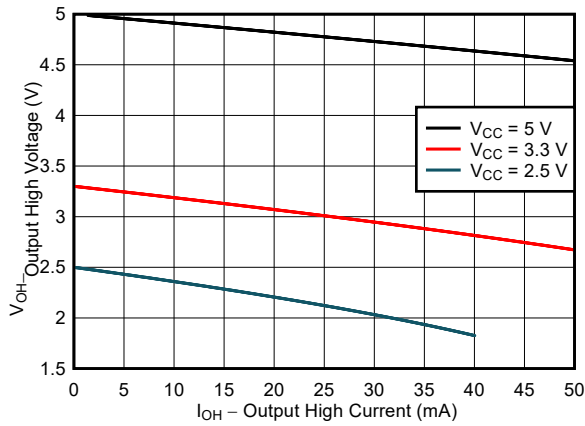

Figure 6-1. Typical ($T_A=25^\circ\text{C}$) Output High Voltage (V_{OH}) vs Source Current (I_{OH})

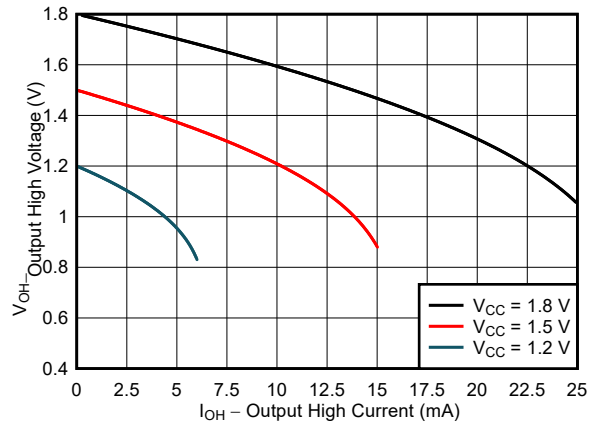

Figure 6-2. Typical ($T_A=25^\circ\text{C}$) Output High Voltage (V_{OH}) vs Source Current (I_{OH})

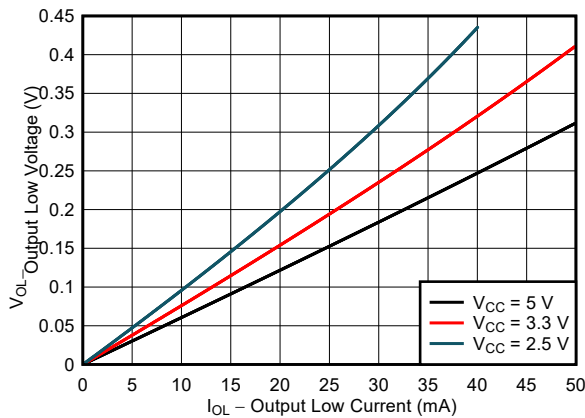

Figure 6-3. Typical ($T_A=25^\circ\text{C}$) Output Low Voltage (V_{OL}) vs Sink Current (I_{OL})

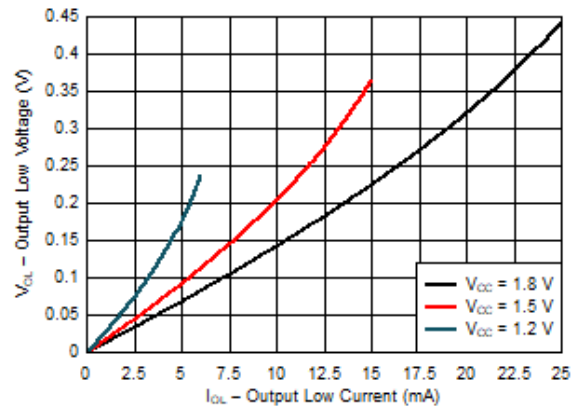

Figure 6-4. Typical ($T_A=25^\circ\text{C}$) Output Low Voltage (V_{OL}) vs Sink Current (I_{OL})

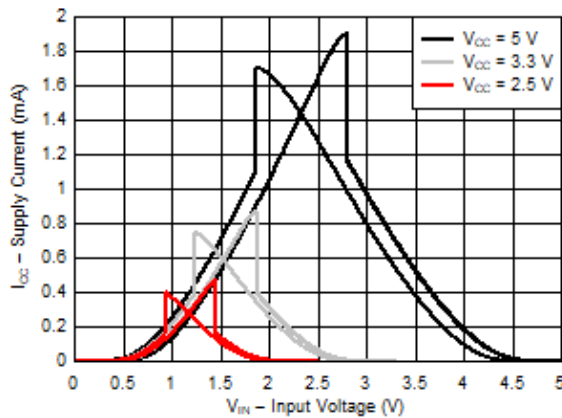

Figure 6-5. Typical ($T_A=25^\circ\text{C}$) Supply Current (I_{CC}) vs Input Voltage (V_{IN})

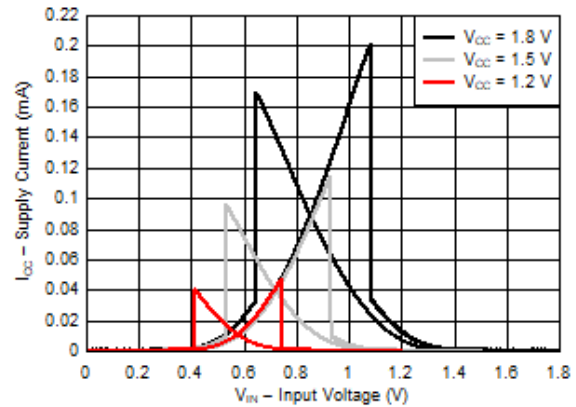

Figure 6-6. Typical ($T_A=25^\circ\text{C}$) Supply Current (I_{CC}) vs Input Voltage (V_{IN})

7 Parameter Measurement Information

7.1 Load Circuit and Voltage Waveforms

Unless otherwise noted, all input pulses are supplied by generators having the following characteristics:

- $f = 1 \text{ MHz}$
- $Z_O = 50 \Omega$
- $\Delta t/\Delta V \leq 1 \text{ ns/V}$

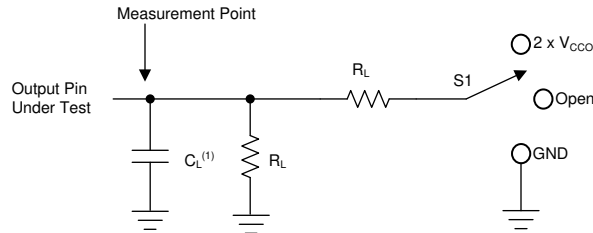

1. C_L includes probe and jig capacitance.

Figure 7-1. Load Circuit

Table 7-1. Load Circuit Conditions

Parameter	V_{CCO}	R_L	C_L	S_1	V_{TP}
t_{pd} Propagation (delay) time	1.1 V – 5.5 V	2 k Ω	15 pF	Open	N/A

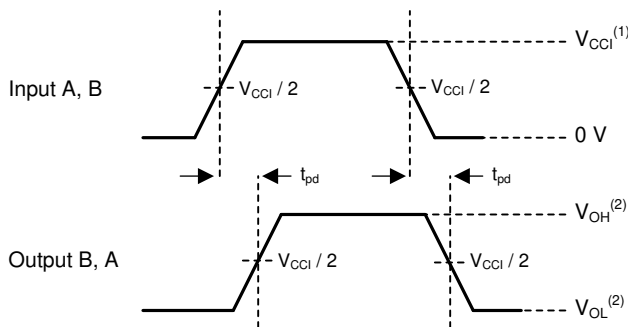

1. V_{CCI} is the supply pin associated with the input port.
2. V_{OH} and V_{OL} are typical output voltage levels that occur with specified R_L , C_L , and S_1

Figure 7-2. Propagation Delay

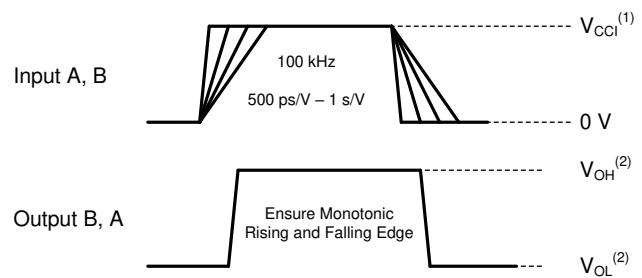

1. V_{CCI} is the supply pin associated with the input port.
2. V_{OH} and V_{OL} are typical output voltage levels that occur with specified R_L , C_L , and S_1

Figure 7-3. Input Transition Rise and Fall Rate

8 Detailed Description

8.1 Overview

The SN74LXC1T14-Q1 is a single bit translating transceiver that uses two individually configurable power-supply rails. The device is operational with both V_{CCI} and V_{CCO} supplies as low as 1.1 V and as high as 5.5 V. The A input is designed to track V_{CCI} , and the Y output is designed to track V_{CCO} .

The SN74LXC1T14-Q1 device is designed for asynchronous communication between devices, and transmits data from A to Y. The input circuitry on the A pin is always active and must have a logic HIGH or LOW level applied to prevent excess I_{CC} and I_{CCZ} .

This device is fully specified for partial-power-down applications using the I_{off} current. The I_{off} protection circuitry ensures that no excessive current is drawn from or sourced into an input or output while the device is powered down.

The V_{CC} isolation or V_{CC} disconnect feature ensures that if either V_{CC} is less than 100 mV or disconnected with the complementary supply within recommended operating conditions, the input is weakly pulled-down and then set to the high-impedance state by disabling their outputs while the supply current is maintained. The $I_{off-float}$ circuitry ensures that no excess current is drawn from or sourced into an input, or output while the supply is floating.

Glitch-free power supply sequencing allows either supply rail to be powered on or off in any order while providing robust power sequencing performance.

8.2 Functional Block Diagram

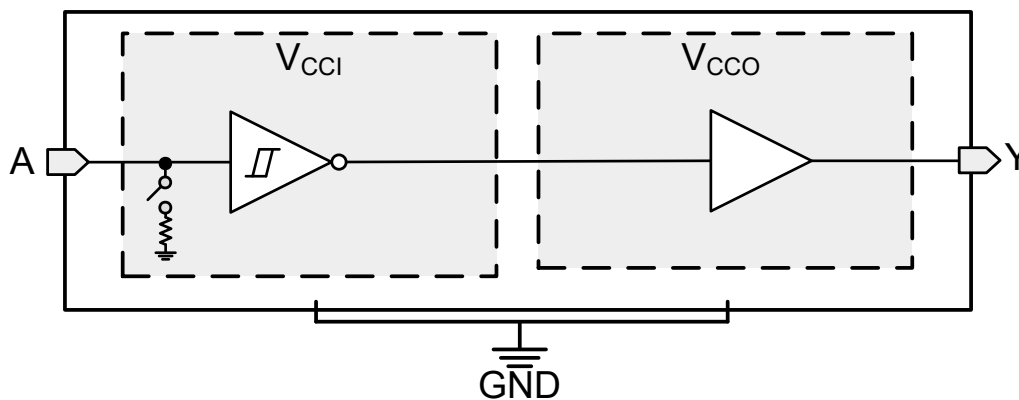

8.3 Feature Description

8.3.1 CMOS Schmitt-Trigger Inputs with Integrated Pulldowns

Standard CMOS inputs are high impedance and are typically modeled as a resistor in parallel with the input capacitance given in the [Electrical Characteristics](#). The worst case resistance is calculated with the maximum input voltage, given in the [Absolute Maximum Ratings](#), and the maximum input leakage current, given in the [Electrical Characteristics](#), using ohm's law ($R = V \div I$).

The Schmitt-trigger input architecture provides hysteresis as defined by ΔV_T in the [Electrical Characteristics](#), which makes this device extremely tolerant to slow or noisy inputs. Driving the inputs slowly will increase dynamic current consumption of the device. For additional information regarding Schmitt-trigger inputs, see [Understanding Schmitt Triggers](#).

8.3.1.1 Input with Integrated Dynamic Pull-Down Resistors

Input circuitry is always active even when the device is disabled. It is recommended to keep a valid voltage level at the input to avoid high current consumption. To help avoid a floating input during disabling, this device has 100-k Ω typical integrated weak dynamic pull-down at the input. When the device is disabled, the dynamic pull-downs are activated for only a short period of time to help drive and keep the floating input low before the device output becomes high impedance. If the input lines will be floated after the device is disabled, it is recommended to keep them at a valid input voltage level using external pull-downs. This feature is ideal for loads of 30 pF or less. If greater capacitive loading is present then external pull-downs are recommended. If an external pull-up is required, it should be no larger than 15 k Ω to avoid contention with the 100 k Ω internal pull-down.

8.3.2 Balanced High-Drive CMOS Push-Pull Outputs

A balanced output allows the device to sink and source similar currents. The high drive capability of this device creates fast edges into light loads so routing and load conditions should be considered to prevent ringing. Additionally, the outputs of this device are capable of driving larger currents than the device can sustain without being damaged. The electrical and thermal limits defined in the [Absolute Maximum Ratings](#) must be followed at all times.

8.3.3 Partial Power Down (I_{off})

The inputs and outputs for this device enter a high-impedance state when the device is powered down, inhibiting current backflow into the device. The maximum leakage into or out of any input or output pin on the device is specified by I_{off} in the [Electrical Characteristics](#).

8.3.4 V_{CC} Isolation and V_{CC} Disconnect (I_{off-float})

This device has an *Input with Integrated Dynamic Pull-Down Resistors*. The input will get pulled down and then enter a high-impedance state when either supply is < 100 mV or left floating (disconnected), while the other supply is still connected to the device. It is recommended to not drive the input for this device, but to keep it at a logic low state prior to floating (disconnecting) either supply.

The maximum supply current is specified by I_{CCx}, while V_{CCx} is floating, in the *Electrical Characteristics*. The maximum leakage into or out of any input or output pin on the device is specified by I_{off(float)} in the *Electrical Characteristics*.

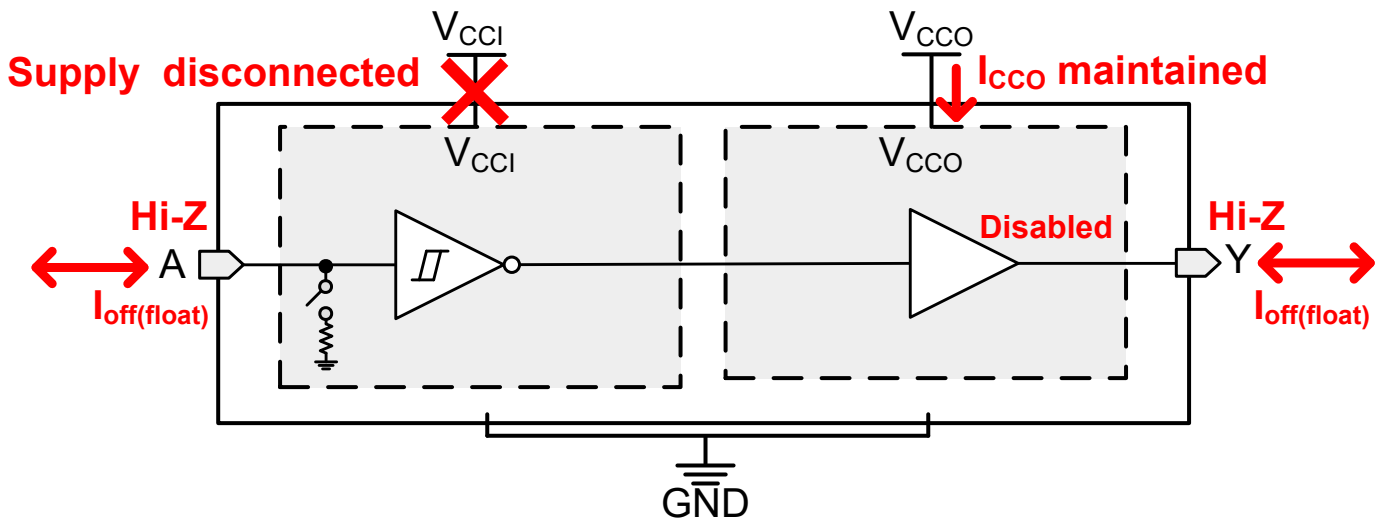

Figure 8-1. V_{CC} Disconnect Feature

8.3.5 Over-Voltage Tolerant Inputs

Input signals to this device can be driven above the supply voltage so long as they remain below the maximum input voltage value specified in the *Recommended Operating Conditions*.

8.3.6 Glitch-Free Power Supply Sequencing

Either supply rail may be powered on or off in any order without producing a glitch on the output (that is, where the output erroneously transitions to V_{CC} when it should be held low or vice versa). Glitches of this nature can be misinterpreted by a peripheral as a valid data bit, which could trigger a false device reset of the peripheral, a false device configuration of the peripheral, or even a false data initialization by the peripheral.

8.3.7 Negative Clamping Diodes

As shown in Figure 8-2, the inputs and outputs to this device have negative clamping diodes.

CAUTION

Voltages beyond the values specified in the [Absolute Maximum Ratings](#) table can cause damage to the device. The input negative-voltage and output voltage ratings may be exceeded if the input and output clamp-current ratings are observed.

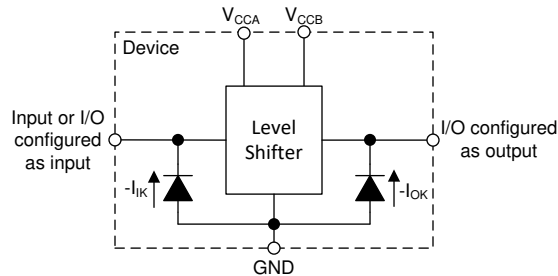

Figure 8-2. Electrical Placement of Clamping Diodes for Each Input and Output

8.3.8 Fully Configurable Dual-Rail Design

Both the V_{CCI} and V_{CCO} pins can be supplied at any voltage from 1.1 V to 5.5 V, making the device suitable for translating between any of the voltage nodes (1.2 V, 1.5 V, 1.8 V, 3.3 V, and 5.0 V).

8.3.9 Supports High-Speed Translation

The SN74LXC1T14-Q1 device can support high data-rate applications. The translated signal data rate can be up to 420 Mbps when the signal is translated from 3.3 V to 5.0 V.

8.4 Device Functional Modes

Table 8-1. Function Table

Input A	Output Y
H	L
L	H

9 Application and Implementation

Note

Information in the following applications sections is not part of the TI component specification, and TI does not warrant its accuracy or completeness. TI's customers are responsible for determining suitability of components for their purposes, as well as validating and testing their design implementation to confirm system functionality.

9.1 Application Information

The SN74LXC1T14-Q1 device can be used in level-translation applications for interfacing devices or systems operating at different interface voltages with one another. The SN74LXC1T14-Q1 device is ideal for use in applications where a push-pull driver is connected to the input. The maximum data rate can be up to 420 Mbps when the device translates a signal from 3.3 V to 5.0 V.

9.2 Typical Application

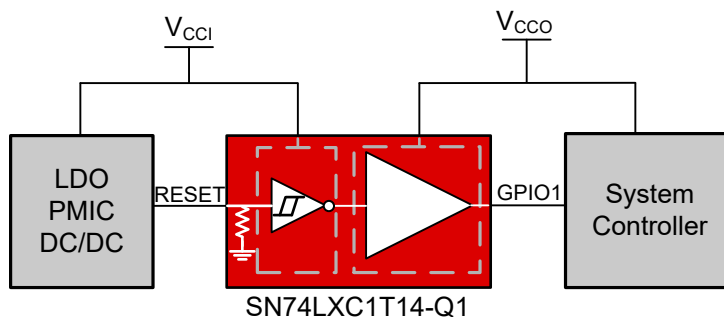

Figure 9-1. LED Driver Application

9.2.1 Design Requirements

For this design example, use the parameters listed in [Table 9-1](#).

Table 9-1. Design Parameters

DESIGN PARAMETERS	EXAMPLE VALUES
Input voltage range	1.1 V to 5.5 V
Output voltage range	1.1 V to 5.5 V

9.2.2 Detailed Design Procedure

To begin the design process, determine the following:

- Input voltage range
 - Use the supply voltage of the device that is driving the SN74LXC1T14-Q1 device to determine the input voltage range. For a valid logic-high, the value must exceed the positive-going input-threshold voltage (V_{t+}) of the input port. For a valid logic low the value must be less than the negative-going input-threshold voltage (V_{t-}) of the input port.
- Output voltage range
 - Use the supply voltage of the device that the SN74LXC1T14-Q1 device is driving to determine the output voltage range.

10 Power Supply Recommendations

Always apply a ground reference to the GND pins first. This device is designed for glitch free power sequencing without any supply sequencing requirements such as ramp order or ramp rate.

This device was designed with various power supply sequencing methods in mind to help prevent unintended triggering of downstream devices, as described in [Glitch-Free Power Supply Sequencing](#).

11 Layout

11.1 Layout Guidelines

To ensure reliability of the device, following common printed-circuit board layout guidelines are recommended:

- Use bypass capacitors on the power supply pins and place them as close to the device as possible. A 0.1 μF capacitor is recommended, but transient performance can be improved by having both 1 μF and 0.1 μF capacitors in parallel as bypass capacitors.
- The high drive capability of this device creates fast edges into light loads so routing and load conditions should be considered to prevent ringing.

11.2 Layout Example

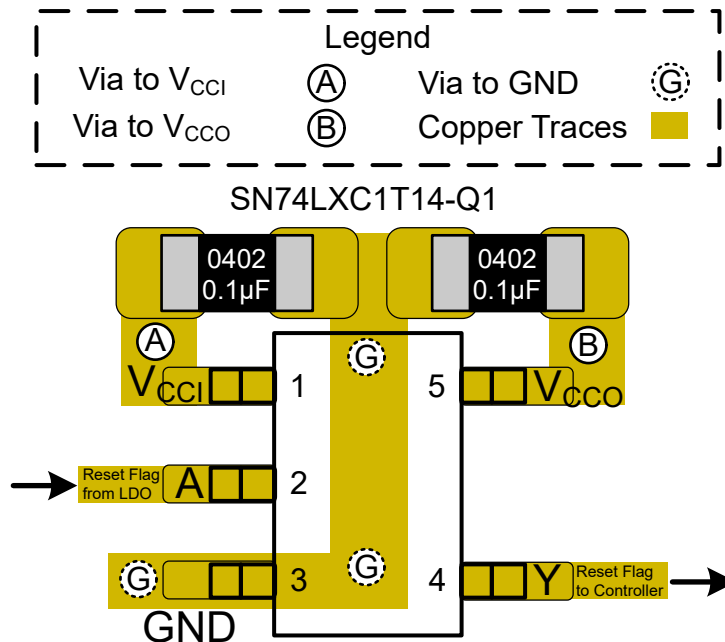

Figure 11-1. Layout Example – SN74LXC1T14-Q1

12 Device and Documentation Support

12.1 Device Support

12.1.1 Regulatory Requirements

No statutory or regulatory requirements apply to this device.

There are no special characteristics for this product.

12.2 Documentation Support

12.2.1 Related Documentation

For related documentation, see the following:

- Texas Instruments, [Understanding Schmitt Triggers applicatin report](#)

12.3 Receiving Notification of Documentation Updates

To receive notification of documentation updates, navigate to the device product folder on [ti.com](#). Click on *Subscribe to updates* to register and receive a weekly digest of any product information that has changed. For change details, review the revision history included in any revised document.

12.4 Support Resources

[TI E2E™ support forums](#) are an engineer's go-to source for fast, verified answers and design help — straight from the experts. Search existing answers or ask your own question to get the quick design help you need.

Linked content is provided "AS IS" by the respective contributors. They do not constitute TI specifications and do not necessarily reflect TI's views; see TI's [Terms of Use](#).

12.5 Trademarks

TI E2E™ is a trademark of Texas Instruments.

All trademarks are the property of their respective owners.

12.6 Electrostatic Discharge Caution



This integrated circuit can be damaged by ESD. Texas Instruments recommends that all integrated circuits be handled with appropriate precautions. Failure to observe proper handling and installation procedures can cause damage.

ESD damage can range from subtle performance degradation to complete device failure. Precision integrated circuits may be more susceptible to damage because very small parametric changes could cause the device not to meet its published specifications.

12.7 Glossary

[TI Glossary](#) This glossary lists and explains terms, acronyms, and definitions.

13 Mechanical, Packaging, and Orderable Information

The following pages include mechanical, packaging, and orderable information. This information is the most current data available for the designated devices. This data is subject to change without notice and revision of this document. For browser-based versions of this data sheet, refer to the left-hand navigation.

PACKAGING INFORMATION

Orderable Device	Status (1)	Package Type	Package Drawing	Pins	Package Qty	Eco Plan (2)	Lead finish/ Ball material (6)	MSL Peak Temp (3)	Op Temp (°C)	Device Marking (4/5)	Samples
SN74LXC1T14QDCKRQ1	ACTIVE	SC70	DKK	5	3000	RoHS & Green	NIPDAU	Level-1-260C-UNLIM	-40 to 125	2OAT	Samples

(1) The marketing status values are defined as follows:

ACTIVE: Product device recommended for new designs.

LIFEBUY: TI has announced that the device will be discontinued, and a lifetime-buy period is in effect.

NRND: Not recommended for new designs. Device is in production to support existing customers, but TI does not recommend using this part in a new design.

PREVIEW: Device has been announced but is not in production. Samples may or may not be available.

OBSOLETE: TI has discontinued the production of the device.

(2) **RoHS:** TI defines "RoHS" to mean semiconductor products that are compliant with the current EU RoHS requirements for all 10 RoHS substances, including the requirement that RoHS substance do not exceed 0.1% by weight in homogeneous materials. Where designed to be soldered at high temperatures, "RoHS" products are suitable for use in specified lead-free processes. TI may reference these types of products as "Pb-Free".

RoHS Exempt: TI defines "RoHS Exempt" to mean products that contain lead but are compliant with EU RoHS pursuant to a specific EU RoHS exemption.

Green: TI defines "Green" to mean the content of Chlorine (Cl) and Bromine (Br) based flame retardants meet JS709B low halogen requirements of <=1000ppm threshold. Antimony trioxide based flame retardants must also meet the <=1000ppm threshold requirement.

(3) MSL, Peak Temp. - The Moisture Sensitivity Level rating according to the JEDEC industry standard classifications, and peak solder temperature.

(4) There may be additional marking, which relates to the logo, the lot trace code information, or the environmental category on the device.

(5) Multiple Device Markings will be inside parentheses. Only one Device Marking contained in parentheses and separated by a "-" will appear on a device. If a line is indented then it is a continuation of the previous line and the two combined represent the entire Device Marking for that device.

(6) Lead finish/Ball material - Orderable Devices may have multiple material finish options. Finish options are separated by a vertical ruled line. Lead finish/Ball material values may wrap to two lines if the finish value exceeds the maximum column width.

Important Information and Disclaimer: The information provided on this page represents TI's knowledge and belief as of the date that it is provided. TI bases its knowledge and belief on information provided by third parties, and makes no representation or warranty as to the accuracy of such information. Efforts are underway to better integrate information from third parties. TI has taken and continues to take reasonable steps to provide representative and accurate information but may not have conducted destructive testing or chemical analysis on incoming materials and chemicals. TI and TI suppliers consider certain information to be proprietary, and thus CAS numbers and other limited information may not be available for release.

In no event shall TI's liability arising out of such information exceed the total purchase price of the TI part(s) at issue in this document sold by TI to Customer on an annual basis.

OTHER QUALIFIED VERSIONS OF SN74LXC1T14-Q1 :

- Catalog : [SN74LXC1T14](#)

NOTE: Qualified Version Definitions:

- Catalog - TI's standard catalog product

TAPE AND REEL INFORMATION

QUADRANT ASSIGNMENTS FOR PIN 1 ORIENTATION IN TAPE

*All dimensions are nominal

Device	Package Type	Package Drawing	Pins	SPQ	Reel Diameter (mm)	Reel Width W1 (mm)	A0 (mm)	B0 (mm)	K0 (mm)	P1 (mm)	W (mm)	Pin1 Quadrant
SN74LXC1T14QDCKRQ1	SC70	DCK	5	3000	178.0	9.0	2.4	2.5	1.2	4.0	8.0	Q3

TAPE AND REEL BOX DIMENSIONS

*All dimensions are nominal

Device	Package Type	Package Drawing	Pins	SPQ	Length (mm)	Width (mm)	Height (mm)
SN74LXC1T14QDCKRQ1	SC70	DCK	5	3000	190.0	190.0	30.0

EXAMPLE BOARD LAYOUT

DCK0005A

SOT - 1.1 max height

SMALL OUTLINE TRANSISTOR

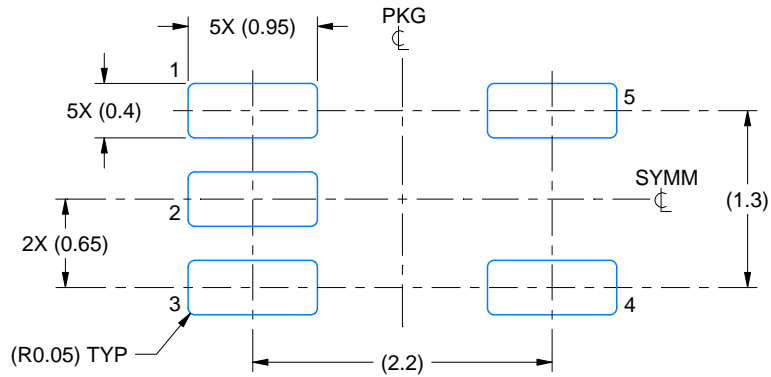

LAND PATTERN EXAMPLE
EXPOSED METAL SHOWN
SCALE:18X

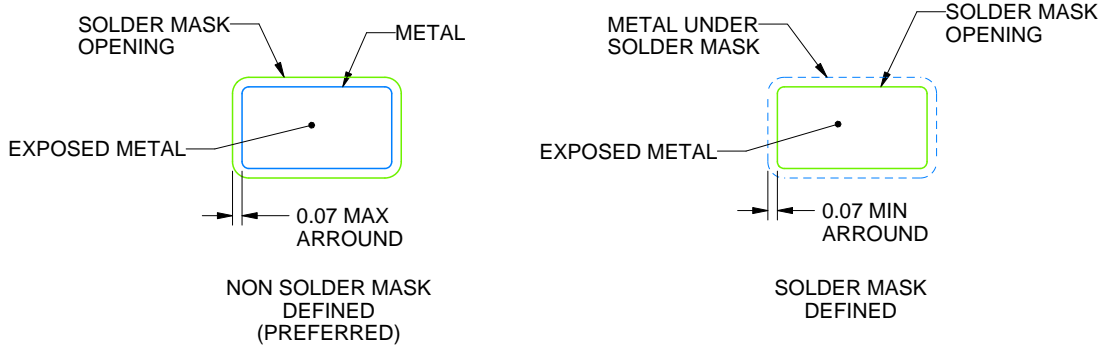

SOLDER MASK DETAILS

4214834/E 06/2024

NOTES: (continued)

- 7. Publication IPC-7351 may have alternate designs.
- 8. Solder mask tolerances between and around signal pads can vary based on board fabrication site.

EXAMPLE STENCIL DESIGN

DCK0005A

SOT - 1.1 max height

SMALL OUTLINE TRANSISTOR

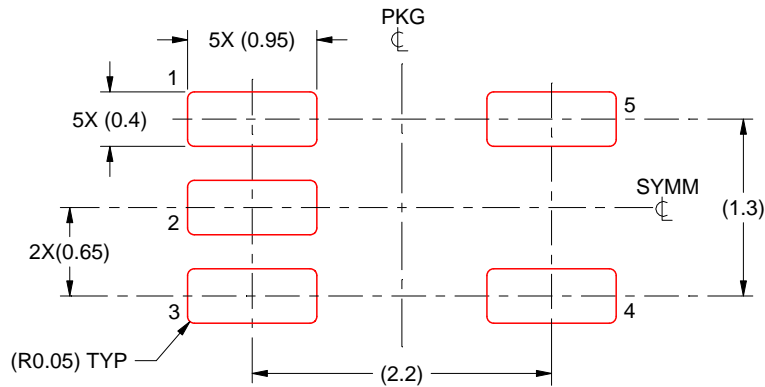

SOLDER PASTE EXAMPLE
BASED ON 0.125 THICK STENCIL
SCALE: 18X

4214834/E 06/2024

NOTES: (continued)

9. Laser cutting apertures with trapezoidal walls and rounded corners may offer better paste release. IPC-7525 may have alternate design recommendations.
10. Board assembly site may have different recommendations for stencil design.

IMPORTANT NOTICE AND DISCLAIMER

TI PROVIDES TECHNICAL AND RELIABILITY DATA (INCLUDING DATA SHEETS), DESIGN RESOURCES (INCLUDING REFERENCE DESIGNS), APPLICATION OR OTHER DESIGN ADVICE, WEB TOOLS, SAFETY INFORMATION, AND OTHER RESOURCES "AS IS" AND WITH ALL FAULTS, AND DISCLAIMS ALL WARRANTIES, EXPRESS AND IMPLIED, INCLUDING WITHOUT LIMITATION ANY IMPLIED WARRANTIES OF MERCHANTABILITY, FITNESS FOR A PARTICULAR PURPOSE OR NON-INFRINGEMENT OF THIRD PARTY INTELLECTUAL PROPERTY RIGHTS.

These resources are intended for skilled developers designing with TI products. You are solely responsible for (1) selecting the appropriate TI products for your application, (2) designing, validating and testing your application, and (3) ensuring your application meets applicable standards, and any other safety, security, regulatory or other requirements.

These resources are subject to change without notice. TI grants you permission to use these resources only for development of an application that uses the TI products described in the resource. Other reproduction and display of these resources is prohibited. No license is granted to any other TI intellectual property right or to any third party intellectual property right. TI disclaims responsibility for, and you will fully indemnify TI and its representatives against, any claims, damages, costs, losses, and liabilities arising out of your use of these resources.

TI's products are provided subject to [TI's Terms of Sale](#) or other applicable terms available either on [ti.com](https://www.ti.com) or provided in conjunction with such TI products. TI's provision of these resources does not expand or otherwise alter TI's applicable warranties or warranty disclaimers for TI products.

TI objects to and rejects any additional or different terms you may have proposed.

Mailing Address: Texas Instruments, Post Office Box 655303, Dallas, Texas 75265
Copyright © 2024, Texas Instruments Incorporated

Looking for pricing, stock, or lifecycle information?

Click below to explore more details on WIN SOURCE:

 [View SN74LXC1T14QDCKRQ1 on WIN SOURCE](#)

 [Texas Instruments](#) Information

Optimize Your Supply Chain with WIN SOURCE Solutions

-  Global Sourcing Solution
-  Obsolete Management
-  Cost Control Management
-  Shortage Management
-  Alternative Solution
-  Excess Inventory Management