



**THE DATASHEET OF
ISL43210HZ-T7A**



ISL43210

Low-Voltage, Single Supply, Single SPDT Analog Switch

FN6563
Rev 2.00
Oct 30, 2007

The Intersil ISL43210 device is a precision, bidirectional, single SPDT analog switch designed to operate from a single +2.7V to +12V supply. Targeted applications include battery powered equipment that benefit from the devices' low power consumption (5μW), low leakage currents (3nA max), and fast switching speeds ($t_{ON} = 28ns$, $t_{OFF} = 20ns$). Cell phones, for example, often face ASIC functionality limitations. The number of analog input or GPIO pins may be limited and digital geometries are not well suited to analog switch performance. This device may be used to "mux-in" additional functionality while reducing ASIC design risk. It's small package alleviates board space limitations, making it an ideal solution.

The ISL43210 is a single committed SPDT, which is perfect for use in 2-to-1 multiplexer applications.

TABLE 1. FEATURES AT A GLANCE

	ISL43210
SW 1/SW 2	SPDT or 2x1 MUX
3.3V r_{ON}	32Ω
3.3V t_{ON}/t_{OFF}	40ns/20ns
5V r_{ON}	19Ω
5V t_{ON}/t_{OFF}	28ns/20ns
12V r_{ON}	11Ω
12V t_{ON}/t_{OFF}	25ns/17ns
Package	6 Ld SOT-23

Related Literature

- Technical Brief TB363 "Guidelines for Handling and Processing Moisture Sensitive Surface Mount Devices (SMDs)"
- Application Note AN557 "Recommended Test Procedures for Analog Switches"

Features

- Fully specified at 12V, 5V, and 3.3V supplies for 10% tolerances
- ON-resistance (r_{ON}) 19Ω
- r_{ON} matching between channels <1Ω
- Low charge injection 5pC (Max)
- Single supply operation +2.7V to +12V
- Low power consumption (P_D) <5μW
- Low leakage current. 10nA
- Fast switching action
 - t_{ON} 28ns
 - t_{OFF} 20ns
- Guaranteed break-before-make switching
- Minimum 2000V ESD protection per method 3015.7
- TTL, CMOS compatible
- Available in 6 Ld SOT-23 package
- Pb-free available (RoHS compliant)

Applications

- Battery-powered, handheld, and portable equipment
 - Cellular/mobile phones
 - Pagers
 - Laptops, notebooks, palmtops
- Communications systems
 - Radios, ADSL Modems
 - PBX, PABX
- Test and measurement equipment
 - Ultrasound
 - Computerized Tomography (CT) Scanner
 - Magnetic Resonance Image (MRI)
 - Positron Emission Tomography (PET) Scanner
 - Electrocardiograph
- Heads-up displays
- Audio and video switching
- Various circuits
 - +3V/+5V DACs and ADCs
 - Sample and hold circuits
 - Digital filters
 - Operational amplifier gain switching networks
 - High frequency analog switching
 - High speed multiplexing
 - Integrator reset circuits

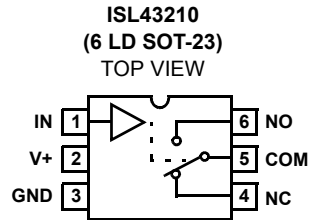
Pinout (Note 1)

NOTE:

1. Switch Shown for Logic "0" Input.

Truth Table

LOGIC	ISL43210	
	PIN NC	PIN NO
0	ON	OFF
1	OFF	ON

NOTE: Logic "0" $\leq 0.8V$. Logic "1" $\geq 2.4V$.**Pin Descriptions**

PIN NAME	PIN NUMBER	FUNCTION
V+	2	System Power Supply Input (+2.7V to +12V)
GND	3	Ground Connection
IN	1	Digital Control Input
COM	5	Analog Switch Common Pin
NO	6	Analog Switch Normally Open Pin
NC	4	Analog Switch Normally Closed Pin

Ordering Information

PART NUMBER	PART MARKING	TEMP. RANGE (°C)	PACKAGE	PKG. DWG. #
ISL43210IH-T*	123I	-40 to +85	6 Ld SOT-23 Tape and Reel	P6.064
ISL43210IHZ-T* (Note)	123Z	-40 to +85	6 Ld SOT-23 (Pb-free) Tape and Reel	P6.064

*Please refer to TB347 for details on reel specifications.

NOTE: These Intersil Pb-free plastic packaged products employ special Pb-free material sets; molding compounds/die attach materials and 100% matte tin plate PLUS ANNEAL - e3 termination finish, which is RoHS compliant and compatible with both SnPb and Pb-free soldering operations. Intersil Pb-free products are MSL classified at Pb-free peak reflow temperatures that meet or exceed the Pb-free requirements of IPC/JEDEC J STD-020.

Absolute Maximum Ratings

V+ to GND	-0.3 to 15V
Input Voltages	
IN (Note 2)	-0.3 to ((V+) + 0.3V)
NO, NC (Note 2)	-0.3 to ((V+) + 0.3V)
Output Voltages	
COM (Note 2)	-0.3 to ((V+) + 0.3V)
Continuous Current (Any Terminal)	30mA
Peak Current NO, NC, or COM (Pulsed 1ms, 10% Duty Cycle, Max)	40mA
ESD Rating	
Human Body Model (Per MIL-STD-883 Method 3015)	2kV

Operating Conditions

Temperature Range	-40°C to +85°C
-------------------	----------------

CAUTION: Do not operate at or near the maximum ratings listed for extended periods of time. Exposure to such conditions may adversely impact product reliability and result in failures not covered by warranty.

NOTES:

- Signals on NC, NO, COM, or IN exceeding V+ or GND are clamped by internal diodes. Limit forward diode current to maximum current ratings.
- θ_{JA} is measured with the component mounted on a low effective thermal conductivity test board in free air. See Tech Brief TB379 for details.

Electrical Specifications - 5V Supply

Test Conditions: V+ = +4.5V to +5.5V, GND = 0V, V_{INH} = 2.4V, V_{INL} = 0.8V (Note 4), Unless Otherwise Specified.

PARAMETER	TEST CONDITIONS	TEMP (°C)	MIN (Notes 5, 6)	TYP	MAX (Notes 5, 6)	UNITS
ANALOG SWITCH CHARACTERISTICS						
Analog Signal Range, V_{ANALOG}		Full	0	-	V+	V
ON-Resistance, r_{ON}	V+ = 4.5V, I_{COM} = 1.0mA, V_{NO} or V_{NC} = 3.5V (See Figure 5)	25	-	19	30	Ω
		Full	-	23	40	Ω
r_{ON} Matching Between Channels, Δr_{ON}	V+ = 5V, I_{COM} = 1.0mA, V_{NO} or V_{NC} = 3.5V	25	-	0.8	2	Ω
		Full	-	1	4	Ω
r_{ON} Flatness, $R_{FLAT(ON)}$	V+ = 5V, I_{COM} = 1.0mA, V_{NO} or V_{NC} = 1V, 2V, 3V (Note 7)	Full	-	7	8	Ω
NO or NC OFF Leakage Current, $I_{NO(OFF)}$ or $I_{NC(OFF)}$	V+ = 5.5V, V_{COM} = 1V, 4.5V, V_{NO} or V_{NC} = 4.5V, 1V	25	-3	0.01	3	nA
		Full	-5	-	5	nA
COM OFF Leakage Current, $I_{COM(OFF)}$	V+ = 5.5V, V_{COM} = 4.5V, 1V, V_{NO} or V_{NC} = 1V, 4.5V	25	-3	-	3	nA
		Full	-5	-	5	nA
COM ON Leakage Current, $I_{COM(ON)}$	V+ = 5.5V, V_{COM} = 1V, 4.5V, or V_{NO} or V_{NC} = 1V, 4.5V or Floating	25	-5	-	5	nA
		Full	-10	-	10	nA
DYNAMIC CHARACTERISTICS						
Turn-ON Time, t_{ON}	V_{NO} or V_{NC} = 3V, R_L = 1k Ω , C_L = 35pF, V_{IN} = 0V to 3V (See Figure 1)	25	-	28	-	ns
		Full	-	40	-	ns
Turn-OFF Time, t_{OFF}	V_{NO} or V_{NC} = 3V, R_L = 1k Ω , C_L = 35pF, V_{IN} = 0V to 3V (See Figure 1)	25	-	20	-	ns
		Full	-	30	-	ns
Break-Before-Make Time Delay, t_D	R_L = 300 Ω , C_L = 35pF, V_{NO} = V_{NC} = 3V, V_{IN} = 0V to 3V (See Figure 3)	Full	-	10	-	ns
Charge Injection, Q	C_L = 1.0nF, V_G = 0V, R_G = 0 Ω (See Figure 2)	25	-	3	-	pC
OFF Isolation	R_L = 50 Ω , C_L = 5pF, f = 1MHz (See Figure 4)	25	-	76	-	dB
Power Supply Rejection Ratio	R_L = 50 Ω , C_L = 5pF, f = 1MHz	25	-	60	-	dB
NO or NC OFF Capacitance, C_{OFF}	f = 1MHz, V_{NO} or V_{NC} = V_{COM} = 0V (See Figure 7)	25	-	8	-	pF
COM OFF Capacitance, $C_{COM(OFF)}$	f = 1MHz, V_{NO} or V_{NC} = V_{COM} = 0V (See Figure 7)	25	-	8	-	pF
COM ON Capacitance, $C_{COM(ON)}$	f = 1MHz, V_{NO} or V_{NC} = V_{COM} = 0V (See Figure 7)	25	-	28	-	pF

Thermal Information

Thermal Resistance (Typical, Note 3)	θ_{JA} (°C/W)
6 Ld SOT-23 Package	230
Maximum Junction Temperature (Plastic Package)	+150°C
Maximum Storage Temperature Range	-65°C to +150°C
Pb-free reflow profile	see link below
	http://www.intersil.com/pbfree/Pb-FreeReflow.asp

Electrical Specifications - 5V Supply

Test Conditions: $V_+ = +4.5V$ to $+5.5V$, $GND = 0V$, $V_{INH} = 2.4V$, $V_{INL} = 0.8V$ (Note 4),
Unless Otherwise Specified. (Continued)

PARAMETER	TEST CONDITIONS	TEMP (°C)	MIN (Notes 5, 6)	TYP	MAX (Notes 5, 6)	UNITS
POWER SUPPLY CHARACTERISTICS						
Power Supply Range		Full	2.7	-	12	V
Positive Supply Current, I_+	$V_+ = 5.5V$, $V_{IN} = 0V$ or V_+ , all channels on or off	Full	-1	0.0001	1	μA
DIGITAL INPUT CHARACTERISTICS						
Input Voltage Low, V_{INL}		Full	-	-	0.8	V
Input Voltage High, V_{INH}		Full	2.4	-	-	V
Input Current, I_{INH} , I_{INL}	$V_+ = 5.5V$, $V_{IN} = 0V$ or V_+	Full	-1	-	1	μA

Electrical Specifications - 3.3V Supply

Test Conditions: $V_+ = +3.0V$ to $+3.6V$, $GND = 0V$, $V_{INH} = 2.4V$, $V_{INL} = 0.8V$ (Note 4),
Unless Otherwise Specified.

PARAMETER	TEST CONDITIONS	TEMP (°C)	MIN (Notes 5, 6)	TYP	MAX (Notes 5, 6)	UNITS
ANALOG SWITCH CHARACTERISTICS						
Analog Signal Range, V_{ANALOG}		Full	0	-	V_+	V
ON-Resistance, r_{ON}	$V_+ = 3V$, $I_{COM} = 1.0mA$, V_{NO} or $V_{NC} = 1.5V$	25	-	32	50	Ω
r_{ON} Matching Between Channels, Δr_{ON}	$V_+ = 3.3V$, $I_{COM} = 1.0mA$, V_{NO} or $V_{NC} = 1.5V$	Full	-	40	60	Ω
		25	-	0.8	2	Ω
r_{ON} Flatness, $R_{FLAT(ON)}$	$V_+ = 3.3V$, $I_{COM} = 1.0mA$, V_{NO} or $V_{NC} = 0.5V$, $1V$, $1.5V$	Full	-	1	4	Ω
		25	-	6	10	Ω
NO or NC OFF Leakage Current, $I_{NO(OFF)}$ or $I_{NC(OFF)}$	$V_+ = 3.6V$, $V_{COM} = 1V$, $3V$, V_{NO} or $V_{NC} = 3V$, $1V$	Full	-	7	12	Ω
		25	-3	0.01	3	nA
COM OFF Leakage Current, $I_{COM(OFF)}$	$V_+ = 3.6V$, $V_{COM} = 3V$, $1V$, V_{NO} or $V_{NC} = 1V$, $3V$	Full	-5	-	5	nA
		25	-3	0.01	3	nA
COM ON Leakage Current, $I_{COM(ON)}$	$V_+ = 3.6V$, $V_{COM} = 1V$, $3V$, or V_{NO} or $V_{NC} = 1V$, $3V$ or floating	Full	-5	-	5	nA
		25	-5	-	5	nA
DYNAMIC CHARACTERISTICS						
Turn-ON Time, t_{ON}	V_{NO} or $V_{NC} = 1.5V$, $R_L = 1k\Omega$, $C_L = 35pF$, $V_{IN} = 0V$ to $3V$	Full	-	40	-	ns
		25	-	60	-	ns
Turn-OFF Time, t_{OFF}	V_{NO} or $V_{NC} = 1.5V$, $R_L = 1k\Omega$, $C_L = 35pF$, $V_{IN} = 0V$ to $3V$	Full	-	20	-	ns
		25	-	30	-	ns
Break-Before-Make Time Delay, t_D	$R_L = 300\Omega$, $C_L = 35pF$, V_{NO} or $V_{NC} = 1.5V$, $V_{IN} = 0V$ to $3V$	Full	-	20	-	ns
Charge Injection, Q	$C_L = 1.0nF$, $V_G = 0V$, $R_G = 0\Omega$	25	-	1	-	pC
OFF Isolation	$R_L = 50\Omega$, $C_L = 5pF$, $f = 1MHz$	25	-	76	-	dB
Power Supply Rejection Ratio	$R_L = 50\Omega$, $C_L = 5pF$, $f = 1MHz$	25	-	56	-	dB
NO or NC OFF Capacitance, C_{OFF}	$f = 1MHz$, V_{NO} or $V_{NC} = V_{COM} = 0V$	25	-	8	-	pF
COM OFF Capacitance, $C_{COM(OFF)}$	$f = 1MHz$, V_{NO} or $V_{NC} = V_{COM} = 0V$	25	-	8	-	pF
COM ON Capacitance, $C_{COM(ON)}$	$f = 1MHz$, V_{NO} or $V_{NC} = V_{COM} = 0V$ (See Figure 7)	25	-	28	-	pF
POWER SUPPLY CHARACTERISTICS						
Positive Supply Current, I_+	$V_+ = 3.6V$, $V_{IN} = 0V$ or V_+ , all channels on or off	Full	-1	-	1	μA

Electrical Specifications - 3.3V Supply

Test Conditions: $V_+ = +3.0V$ to $+3.6V$, $GND = 0V$, $V_{INH} = 2.4V$, $V_{INL} = 0.8V$ (Note 4),
Unless Otherwise Specified. (Continued)

PARAMETER	TEST CONDITIONS	TEMP (°C)	MIN (Notes 5, 6)	TYP	MAX (Notes 5, 6)	UNITS
DIGITAL INPUT CHARACTERISTICS						
Input Voltage Low, V_{INL}		Full	-	-	0.8	V
Input Voltage High, V_{INH}		Full	2.4	-	-	V
Input Current, I_{INH} , I_{INL}	$V_+ = 3.6V$, $V_{IN} = 0V$ or V_+	Full	-1	-	1	μA

Electrical Specifications - 12V Supply

Test Conditions: $V_+ = +10.8V$ to $+13V$, $GND = 0V$, $V_{INH} = 4V$, $V_{INL} = 0.8V$ (Note 4),
Unless Otherwise Specified.

PARAMETER	TEST CONDITIONS	TEMP (°C)	MIN (Notes 5, 6)	TYP	MAX (Notes 5, 6)	UNITS
ANALOG SWITCH CHARACTERISTICS						
Analog Signal Range, V_{ANALOG}		Full	0	-	V_+	V
ON-Resistance, r_{ON}	$V_+ = 10.8V$, $I_{COM} = 1.0mA$, V_{NO} or $V_{NC} = 10V$	25	-	11	20	Ω
		Full	-	15	25	Ω
r_{ON} Matching Between Channels, Δr_{ON}	$V_+ = 12V$, $I_{COM} = 1.0mA$, V_{NO} or $V_{NC} = 10V$	25	-	0.8	2	Ω
		Full	-	1	4	Ω
r_{ON} Flatness, $R_{FLAT(ON)}$	$V_+ = 12V$, $I_{COM} = 1.0mA$, V_{NO} or $V_{NC} = 3V, 6V, 9V$ (Note 7)	25	-	1	4	Ω
		Full	-	-	6	Ω
NO or NC OFF Leakage Current, $I_{NO(OFF)}$ or $I_{NC(OFF)}$	$V_+ = 13V$, $V_{COM} = 1V, 12V$, V_{NO} or $V_{NC} = 12V, 1V$	25	-3	0.01	3	nA
		Full	-5	-	5	nA
COM OFF Leakage Current, $I_{COM(OFF)}$	$V_+ = 13V$, $V_{COM} = 12V, 1V$, V_{NO} or $V_{NC} = 1V, 12V$	25	-3	0.01	3	nA
		Full	-5	-	5	nA
COM ON Leakage Current, $I_{COM(ON)}$	$V_+ = 13V$, $V_{COM} = 1V, 12V$, or V_{NO} or $V_{NC} = 1V, 12V$ or floating	25	-5	-	5	nA
		Full	-10	-	10	nA
DYNAMIC CHARACTERISTICS						
Turn-ON Time, t_{ON}	V_{NO} or $V_{NC} = 10V$, $R_L = 1k\Omega$, $C_L = 35pF$, $V_{IN} = 0V$ to $4V$	25	-	25	-	ns
		Full	-	35	-	ns
Turn-OFF Time, t_{OFF}	V_{NO} or $V_{NC} = 10V$, $R_L = 1k\Omega$, $C_L = 35pF$, $V_{IN} = 0V$ to $4V$	25	-	17	-	ns
		Full	-	26	-	ns
Break-Before-Make Time Delay, t_D	$R_L = 300\Omega$, $C_L = 35pF$, V_{NO} or $V_{NC} = 10V$, $V_{IN} = 0V$ to $4V$	Full	-	2	-	ns
Charge Injection, Q	$C_L = 1.0nF$, $V_G = 0V$, $R_G = 0\Omega$	25	-	5	-	pC
OFF Isolation	$R_L = 50\Omega$, $C_L = 5pF$, $f = 1MHz$	25	-	76	-	dB
Crosstalk (Channel-to-Channel)	$R_L = 50\Omega$, $C_L = 5pF$, $f = 1MHz$	25	-	-105	-	dB
Power Supply Rejection Ratio	$R_L = 50\Omega$, $C_L = 5pF$, $f = 1MHz$	25	-	63	-	dB
NO or NC OFF Capacitance, C_{OFF}	$f = 1MHz$, V_{NO} or $V_{NC} = V_{COM} = 0V$	25	-	8	-	pF
COM OFF Capacitance, $C_{COM(OFF)}$	$f = 1MHz$, V_{NO} or $V_{NC} = V_{COM} = 0V$	25	-	8	-	pF
COM ON Capacitance, $C_{COM(ON)}$	$f = 1MHz$, V_{NO} or $V_{NC} = V_{COM} = 0V$ (See Figure 7)	25	-	28	-	pF
POWER SUPPLY CHARACTERISTICS						
Positive Supply Current, I_+	$V_+ = 13V$, $V_{IN} = 0V$ or V_+ , all channels on or off	Full	-1	-	1	μA

Electrical Specifications - 12V Supply

Test Conditions: $V_+ = +10.8V$ to $+13V$, $GND = 0V$, $V_{INH} = 4V$, $V_{INL} = 0.8V$ (Note 4), Unless Otherwise Specified. (Continued)

PARAMETER	TEST CONDITIONS	TEMP (°C)	MIN (Notes 5, 6)	TYP	MAX (Notes 5, 6)	UNITS
DIGITAL INPUT CHARACTERISTICS						
Input Voltage Low, V_{INL}		Full	-	-	0.8	V
Input Voltage High, V_{INH}		Full	4	-	-	V
Input Current, I_{INH} , I_{INL}	$V_+ = 13V$, $V_{IN} = 0V$ or V_+	Full	-1	-	1	μA

NOTES:

- 4. V_{IN} = input voltage to perform proper function.
- 5. The algebraic convention, whereby the most negative value is a minimum and the most positive a maximum, is used in this data sheet.
- 6. Parts are 100% tested at +25°C. Over-temperature limits established by characterization and are not production tested.
- 7. Limits established by characterization and are not production tested.

Test Circuits and Waveforms

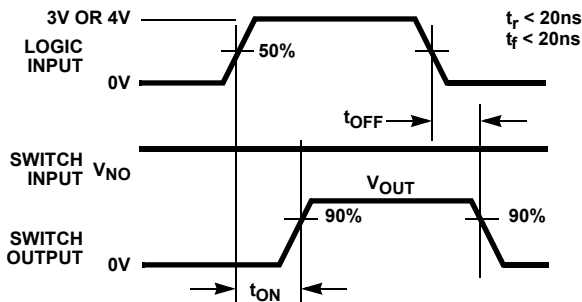

Logic input waveform is inverted for switches that have the opposite logic sense.

FIGURE 1A. MEASUREMENT POINTS

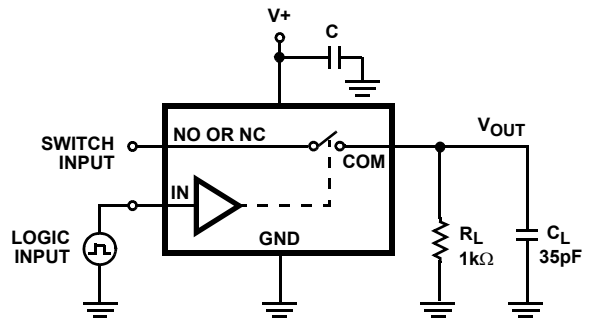

Repeat test for all switches. C_L includes fixture and stray capacitance.

$$V_{OUT} = V_{(NO \text{ or } NC)} \frac{R_L}{R_L + r_{ON}}$$

FIGURE 1B. TEST CIRCUIT

FIGURE 1. SWITCHING TIMES

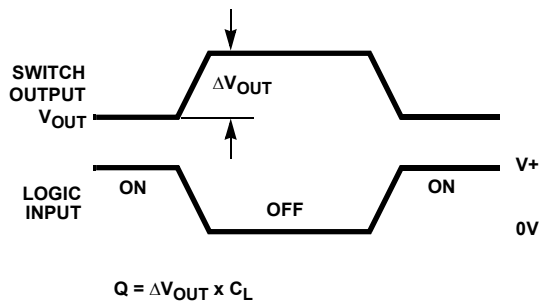

FIGURE 2A. MEASUREMENT POINTS

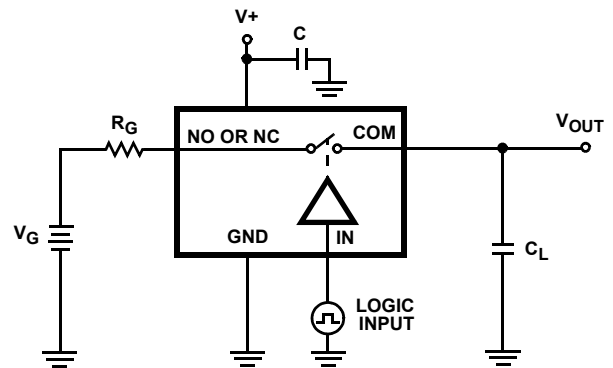

FIGURE 2B. TEST CIRCUIT

FIGURE 2. CHARGE INJECTION

Test Circuits and Waveforms (Continued)

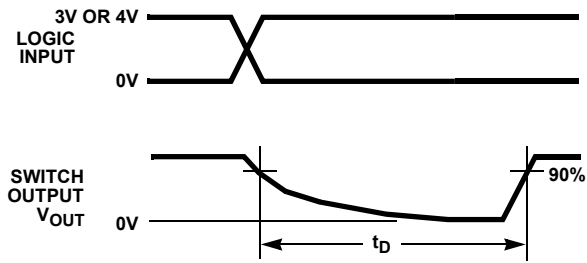
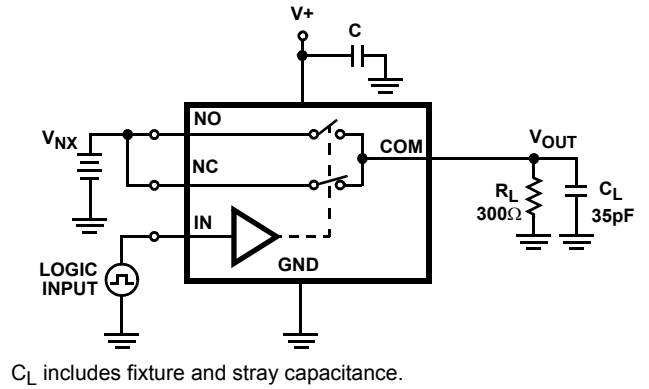

FIGURE 3A. MEASUREMENT POINTS



C_L includes fixture and stray capacitance.

FIGURE 3B. TEST CIRCUIT

FIGURE 3. BREAK-BEFORE-MAKE TIME

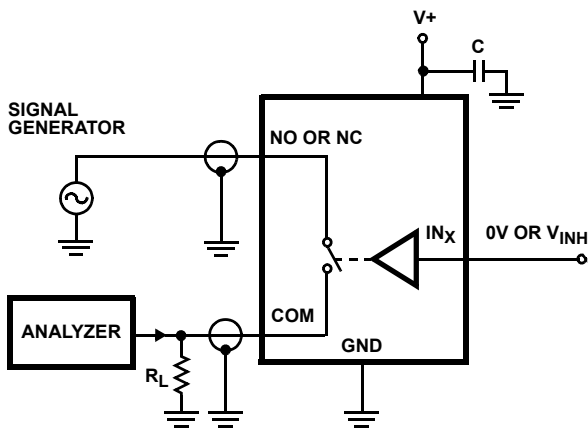

FIGURE 4. OFF ISOLATION TEST CIRCUIT

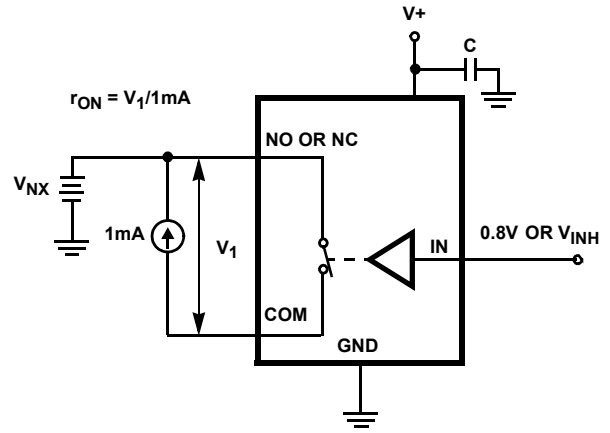

FIGURE 5. r_{ON} TEST CIRCUIT

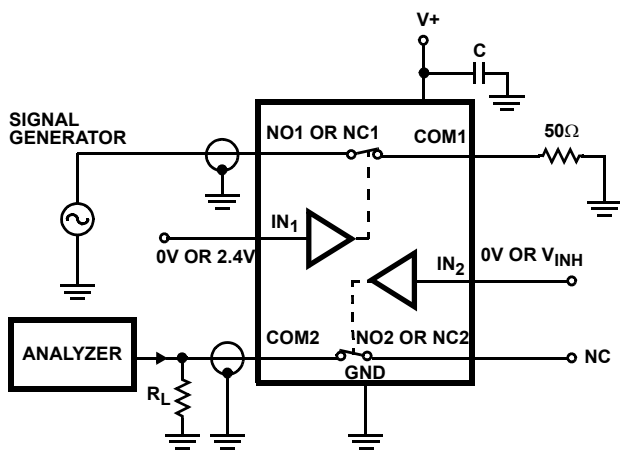

FIGURE 6. CROSSTALK TEST CIRCUIT

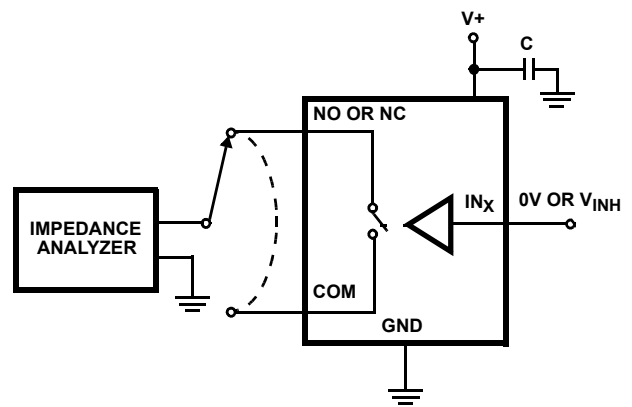

FIGURE 7. CAPACITANCE TEST CIRCUIT

Detailed Description

The ISL43210 bidirectional, single SPDT analog switch offers precise switching capability from a single 2.7V to 12V supply with low ON-resistance (19Ω) and high speed operation ($t_{ON} = 28\text{ns}$, $t_{OFF} = 20\text{ns}$). The device is especially well suited to portable battery powered equipment thanks to the low operating supply voltage (2.7V), low power consumption ($5\mu\text{W}$), low leakage currents (3nA max), and the tiny SOT-23 packaging. High frequency applications also benefit from the wide bandwidth, and the very high off isolation rejection.

Supply Sequencing and Overvoltage Protection

With any CMOS device, proper power supply sequencing is required to protect the device from excessive input currents which might permanently damage the IC. All I/O pins contain ESD protection diodes from the pin to V+ and GND (see Figure 8). To prevent forward biasing these diodes, V+ must be applied before any input signals, and input signal voltages must remain between V+ and GND. If these conditions cannot be guaranteed, then one of the following two protection methods should be employed.

Logic inputs can easily be protected by adding a $1\text{k}\Omega$ resistor in series with the input (see Figure 8). The resistor limits the input current below the threshold that produces permanent damage, and the sub-microamp input current produces an insignificant voltage drop during normal operation.

Adding a series resistor to the switch input defeats the purpose of using a low r_{ON} switch, so two small signal diodes can be added in series with the supply pins to provide overvoltage protection for all pins (see Figure 8). These additional diodes limit the analog signal from 1V below V+ to 1V above GND. The low leakage current performance is unaffected by this approach, but the switch resistance may increase, especially at low supply voltages.

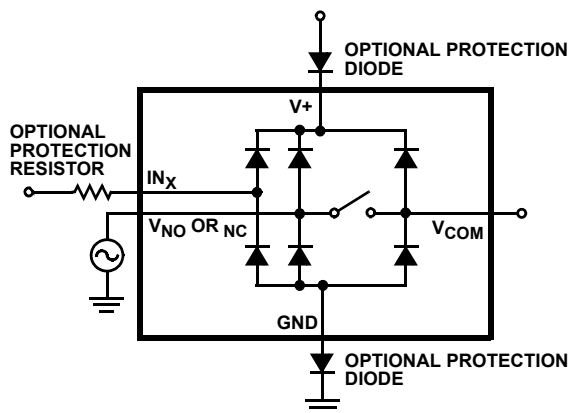

FIGURE 8. OVERVOLTAGE PROTECTION

Power-Supply Considerations

The ISL43210 construction is typical of most CMOS analog switches, except that they have only two supply pins: V+ and GND. V+ and GND drive the internal CMOS switches and set their analog voltage limits. Unlike switches with a 13V maximum supply voltage, the ISL43210 15V maximum supply voltage provides plenty of room for the 10% tolerance of 12V supplies, as well as room for overshoot and noise spikes.

The minimum recommended supply voltage is 2.7V. It is important to note that the input signal range, switching times, and ON-resistance degrade at lower supply voltages. Refer to the “Electrical Specification” tables beginning on page 5 and “Typical Performance Curves” beginning on page 9 for details.

V+ and GND also power the internal logic and level shifter. The level shifter convert the input logic levels to switched V+ and GND signals to drive the analog switch gate terminals.

This device cannot be operated with bipolar supplies, because the input switching point becomes negative in this configuration.

Logic-Level Thresholds

This switch is TTL compatible (0.8V and 2.4V) over a supply range of 3V to 11V (see Figure 15). At 12V the V_{IH} level is about 2.5V. This is still below the TTL guaranteed high output minimum level of 2.8V, but noise margin is reduced. For best results with a 12V supply, use a logic family that provides a V_{OH} greater than 3V.

The digital input stages draw supply current whenever the digital input voltage is not at one of the supply rails. Driving the digital input signals from GND to V+ with a fast transition time minimizes power dissipation.

High-Frequency Performance

In 50Ω systems, signal response is reasonably flat even past 300MHz (see Figure 16). Figure 16 also illustrates that the frequency response is very consistent over a wide V+ range, and for varying analog signal levels.

An OFF switch acts like a capacitor and passes higher frequencies with less attenuation, resulting in signal feedthrough from a switch’s input to its output. Off isolation is the resistance to this feedthrough. Figure 17 details the high off isolation rejection provided by this part. At 10MHz, off isolation is about 50dB in 50Ω systems, decreasing approximately 20dB per decade as frequency increases. Higher load impedances decrease off isolation rejection due to the voltage divider action of the switch OFF impedance and the load impedance.

Leakage Considerations

Reverse ESD protection diodes are internally connected between each analog-signal pin and both V+ and GND. One of

these diodes conducts if any analog signal exceeds V+ or GND.

Virtually all the analog leakage current comes from the ESD diodes to V+ or GND. Although the ESD diodes on a given signal pin are identical and therefore fairly well balanced, they are reverse biased differently. Each is biased by either V+ or GND and the analog signal. This means their leakages will vary as the signal varies. The difference in the two diode

leakages to the V+ and GND pins constitutes the analog-signal-path leakage current. All analog leakage current flows between each pin and one of the supply terminals, not to the other switch terminal. This is why both sides of a given switch can show leakage currents of the same or opposite polarity. There is no connection between the analog signal paths and V+ or GND.

Typical Performance Curves $T_A = +25^\circ\text{C}$, Unless Otherwise Specified.

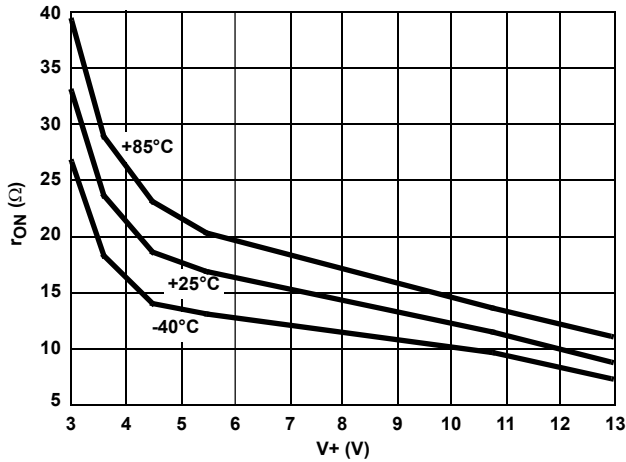

FIGURE 9. ON-RESISTANCE vs SUPPLY VOLTAGE

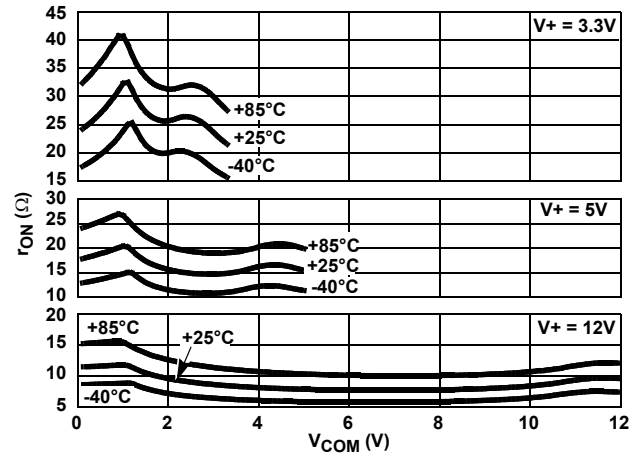

FIGURE 10. ON-RESISTANCE vs SWITCH VOLTAGE

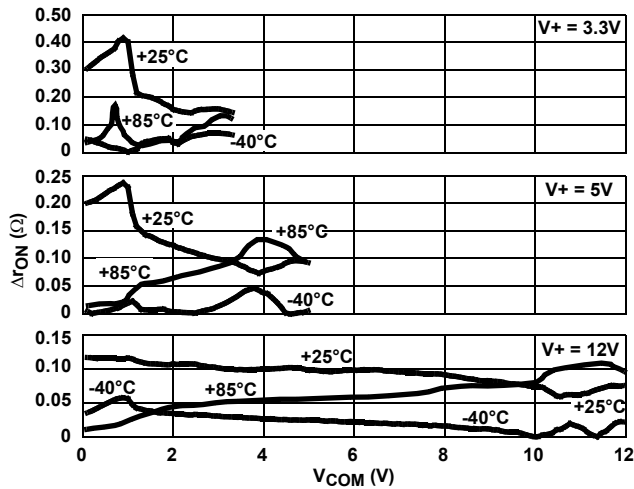

FIGURE 11. r_{ON} MATCH vs SWITCH VOLTAGE

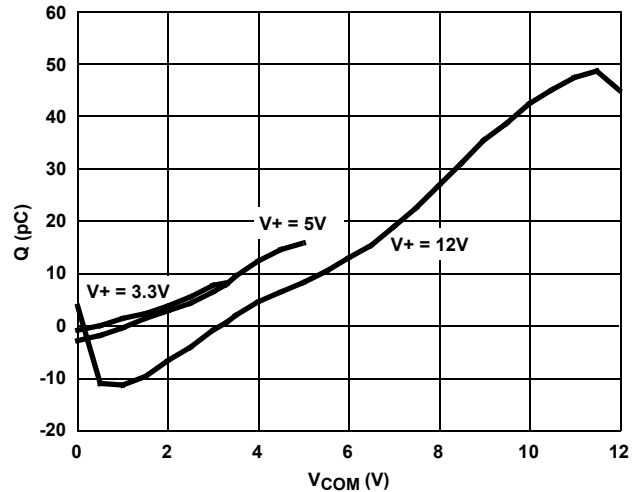

FIGURE 12. CHARGE INJECTION vs SWITCH VOLTAGE

Typical Performance Curves $T_A = +25^\circ\text{C}$, Unless Otherwise Specified. (Continued)

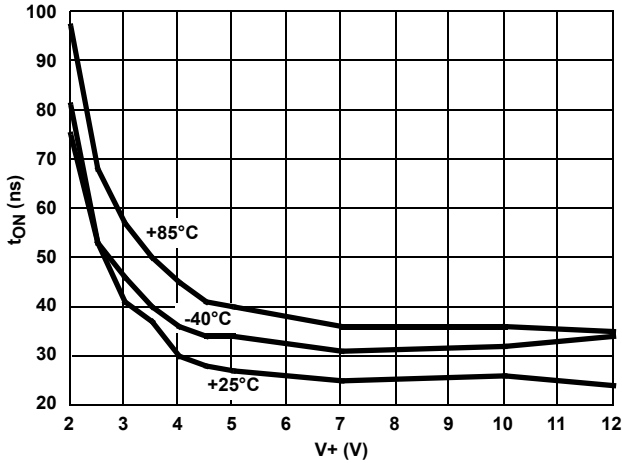

FIGURE 13. TURN-ON TIME vs SUPPLY VOLTAGE

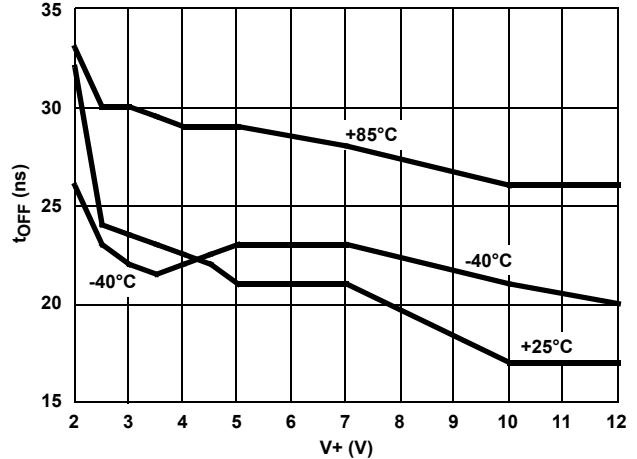

FIGURE 14. TURN-OFF TIME vs SUPPLY VOLTAGE

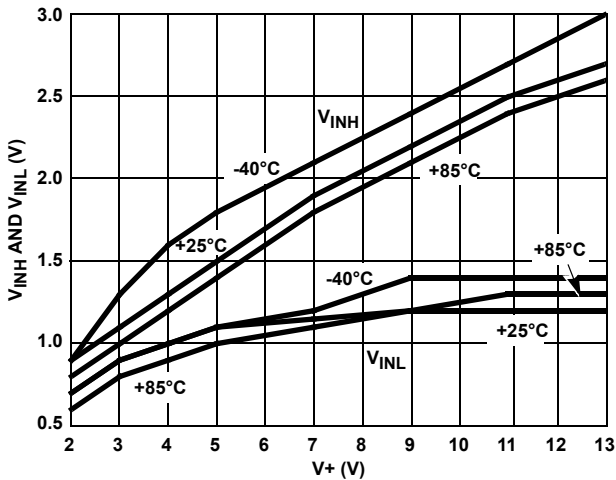

FIGURE 15. DIGITAL SWITCHING POINT vs SUPPLY VOLTAGE

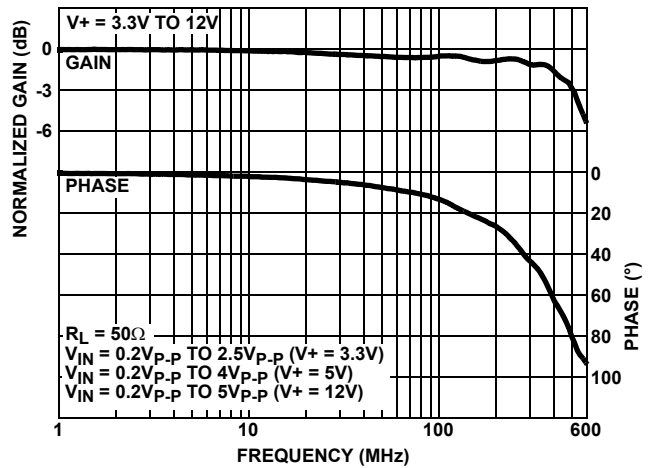

FIGURE 16. FREQUENCY RESPONSE

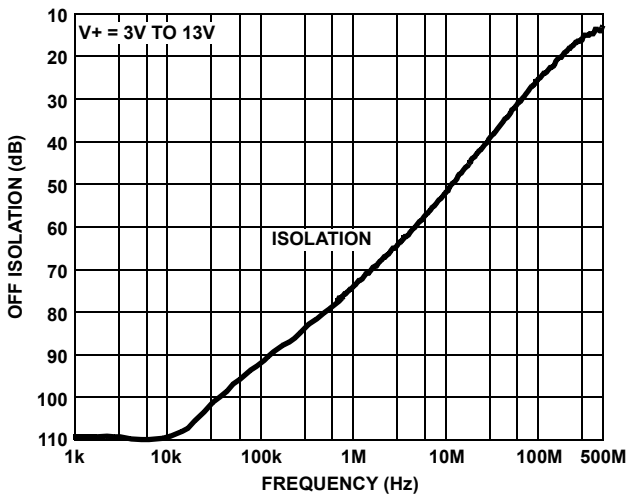

FIGURE 17. OFF ISOLATION

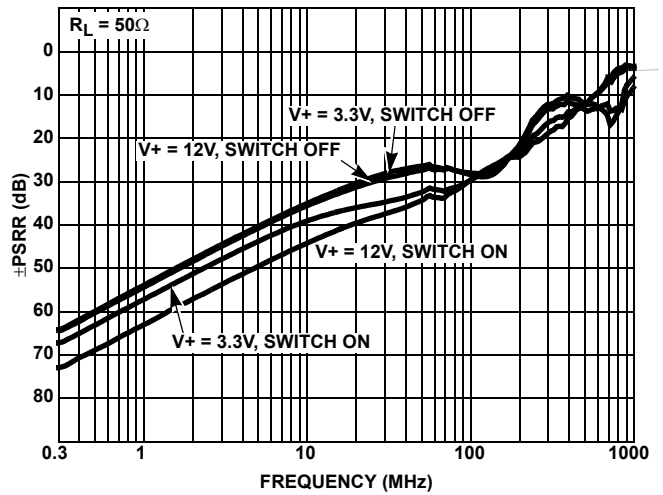

FIGURE 18. \pm PSRR vs FREQUENCY

Die Characteristics

SUBSTRATE POTENTIAL (POWERED UP):

GND

TRANSISTOR COUNT:

ISL43210: 58

PROCESS:

Si Gate CMOS

© Copyright Intersil Americas LLC 2007. All Rights Reserved.

All trademarks and registered trademarks are the property of their respective owners.

For additional products, see www.intersil.com/en/products.html

Intersil products are manufactured, assembled and tested utilizing ISO9001 quality systems as noted in the quality certifications found at www.intersil.com/en/support/qualandreliability.html

Intersil products are sold by description only. Intersil may modify the circuit design and/or specifications of products at any time without notice, provided that such modification does not, in Intersil's sole judgment, affect the form, fit or function of the product. Accordingly, the reader is cautioned to verify that datasheets are current before placing orders. Information furnished by Intersil is believed to be accurate and reliable. However, no responsibility is assumed by Intersil or its subsidiaries for its use; nor for any infringements of patents or other rights of third parties which may result from its use. No license is granted by implication or otherwise under any patent or patent rights of Intersil or its subsidiaries.

For information regarding Intersil Corporation and its products, see www.intersil.com

Small Outline Transistor Plastic Packages (SOT23-6)

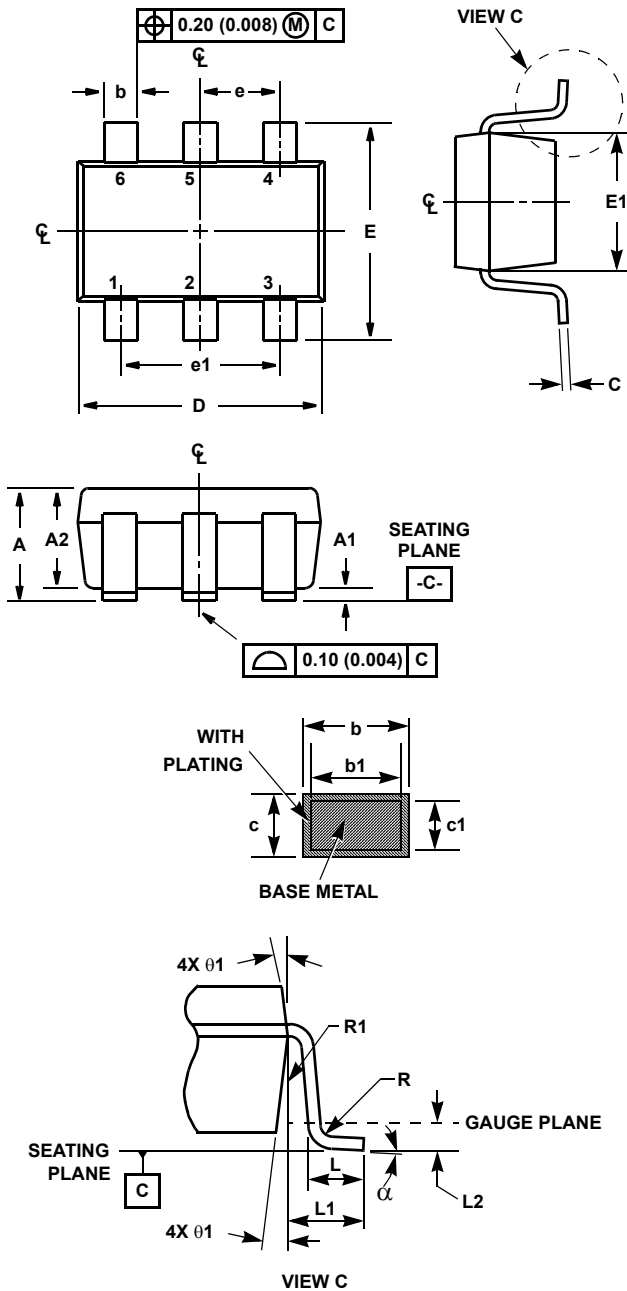

P6.064

6 LEAD SMALL OUTLINE TRANSISTOR PLASTIC PACKAGE

SYMBOL	INCHES		MILLIMETERS		NOTES
	MIN	MAX	MIN	MAX	
A	0.036	0.057	0.90	1.45	-
A1	0.000	0.0059	0.00	0.15	-
A2	0.036	0.051	0.90	1.30	-
b	0.012	0.020	0.30	0.50	-
b1	0.012	0.018	0.30	0.45	-
c	0.003	0.009	0.08	0.22	6
c1	0.003	0.008	0.08	0.20	6
D	0.111	0.118	2.80	3.00	3
E	0.103	0.118	2.60	3.00	-
E1	0.060	0.068	1.50	1.75	3
e	0.0374 Ref		0.95 Ref		-
e1	0.0748 Ref		1.90 Ref		-
L	0.014	0.022	0.35	0.55	4
L1	0.024 Ref.		0.60 Ref.		-
L2	0.010 Ref.		0.25 Ref.		-
N	6		6		5
R	0.004	-	0.10	-	-
R1	0.004	0.010	0.10	0.25	-
α	0°	8°	0°	8°	-



Rev. 3 9/03

NOTES:

1. Dimensioning and tolerance per ASME Y14.5M-1994.
2. Package conforms to EIAJ SC-74 and JEDEC MO178AB.
3. Dimensions D and E1 are exclusive of mold flash, protrusions, or gate burrs.
4. Footlength L measured at reference to gauge plane.
5. "N" is the number of terminal positions.
6. These Dimensions apply to the flat section of the lead between 0.08mm and 0.15mm from the lead tip.
7. Controlling dimension: MILLIMETER. Converted inch dimensions are for reference only

Looking for pricing, stock, or lifecycle information?

Click below to explore more details on WIN SOURCE:

-  [View ISL43210IHZ-T7A on WIN SOURCE](#)
-  [Renesas Electronics America](#) Information

Optimize Your Supply Chain with WIN SOURCE Solutions

-  Global Sourcing Solution
-  Obsolete Management
-  Cost Control Management
-  Shortage Management
-  Alternative Solution
-  Excess Inventory Management