



**THE DATASHEET OF  
MAX77734BENP+T**



Click [here](#) to ask an associate for production status of specific part numbers.

## MAX77734

# Ultra-Low Power Tiny PMIC with Power Path Charger for Small Li+ and 150mA LDO

### General Description

The MAX77734 is a tiny PMIC for applications where size and simplicity are critical. The IC integrates a linear-mode Li+ battery charger, low-dropout linear regulator (LDO), analog multiplexer, and dual-channel current sink driver.

The charger is designed for small-battery systems that require accurate termination as low as 0.375mA. The circuit can instantly regulate the system voltage when an input source is connected even if the battery is depleted.

The 150mA LDO's output is programmable between 0.8V and 3.975V with I<sup>2</sup>C. The analog MUX enables an external ADC to perform conversions on battery V&I signals for power monitoring. The current sinks are capable of sinking 12.8mA each and can be programmed for LEDs to blink in custom patterns.

The MAX77734 is available in a 20-bump, 0.4mm pitch, wafer-level package (WLP).

### Applications

- Hearables: Headsets, Headphones, Earbuds
- Fitness Bands and other Bluetooth Wearables
- Action Cameras, Wearable/Body Cameras
- Low-Power Internet of Things (IoT) Gadgets

### Benefits and Features

- Extends Battery Life
  - 200nA Factory-Ship Mode for Long Shelf Life
  - 500nA Shutdown Current
  - 4.5µA Quiescent Current with LDO Enabled
  - Charger Allows Battery to Relax after Charging
- Linear Charger Optimized for Small Battery Size
  - 7.5mA to 300mA Fast-Charge Current
  - Battery Regulation Voltage from 3.6V to 4.6V
  - Accurate Termination Current as low as 0.375mA
  - Instant-On Functionality provided by Maxim's Smart Power Selector™
  - JEITA Battery Temperature Monitors for Safe Charging
- Highly Integrated
  - 150mA LDO with Power-OK Output
  - Dual-Channel Current Sink for LEDs
  - Analog Multiplexer for Power Monitoring
  - Watchdog Timer
  - On-Key Input for LDO Enable and Manual Reset
- Small Size
  - 2.23mm x 1.97mm (0.5mm max height) WLP
  - 20-Bump, 0.4mm Pitch, 4 x 5 Array

### Simplified Application Circuit

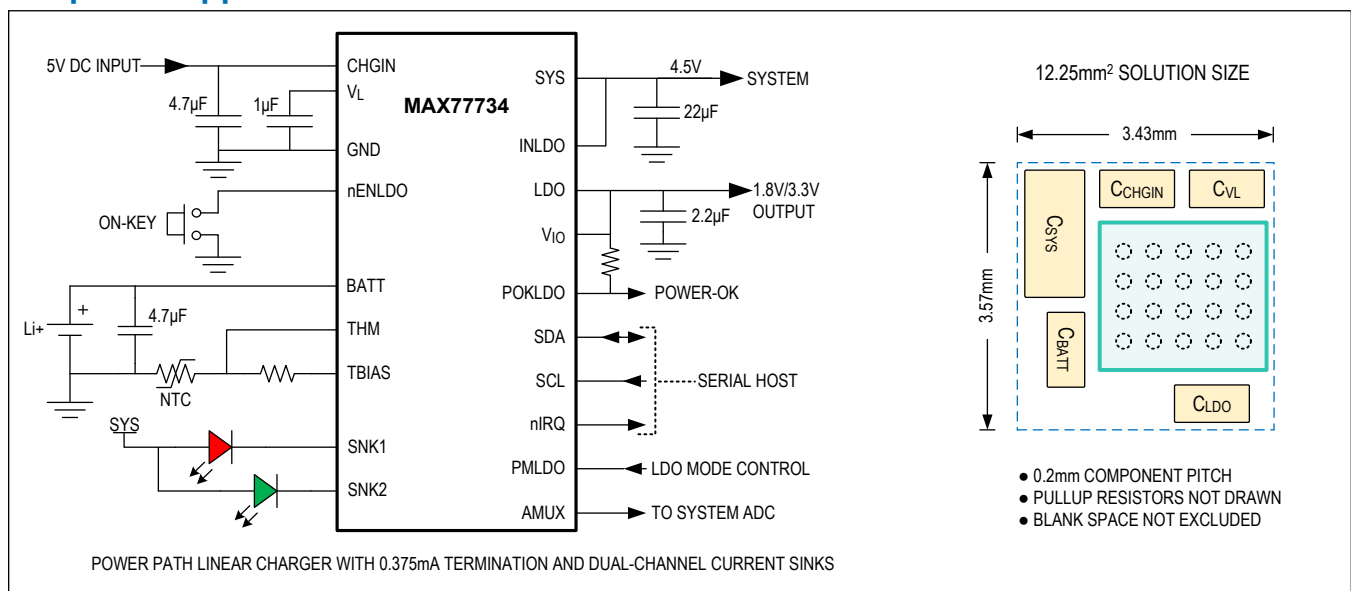

Smart Power Selector is a trademark of Maxim Integrated Products, Inc.

[Ordering Information](#) appears at end of datasheet.

19-100062; Rev 6; 4/23

© 2023 Analog Devices, Inc. All rights reserved. Trademarks and registered trademarks are the property of their respective owners.

One Analog Way, Wilmington, MA 01887 U.S.A. | Tel: 781.329.4700 | © 2023 Analog Devices, Inc. All rights reserved.

**TABLE OF CONTENTS**

General Description . . . . .	1
Applications . . . . .	1
Benefits and Features . . . . .	1
Simplified Application Circuit . . . . .	1
Absolute Maximum Ratings . . . . .	7
Package Information . . . . .	7
20WLP . . . . .	7
Electrical Characteristics . . . . .	7
Electrical Characteristics—Smart Power Selector Charger . . . . .	9
Electrical Characteristics—Adjustable Thermistor Temperature Monitors . . . . .	12
Electrical Characteristics—Analog Multiplexer . . . . .	13
Electrical Characteristics—Linear Regulator . . . . .	14
Electrical Characteristics—Dual-Channel Current Sink Driver . . . . .	16
Electrical Characteristics—I <sup>2</sup> C Serial Interface . . . . .	17
Typical Operating Characteristics . . . . .	19
Pin Configuration . . . . .	21
MAX77734 . . . . .	21
Pin Description . . . . .	21
Simplified Block Diagram . . . . .	23
MAX77734 . . . . .	23
Detailed Description . . . . .	24
On/Off Controller . . . . .	24
Factory-Ship Mode State . . . . .	28
Shutdown (Bias Off) State . . . . .	28
Standby (Bias On) State . . . . .	28
Resource On State . . . . .	28
Hardware Enable (nENLDO) . . . . .	29
Manual Reset . . . . .	29
Push-Button vs. Slide-Switch Functionality . . . . .	29
nENLDO Pullup Resistors to V <sub>CCINT</sub> (V <sub>CC</sub> Internal) . . . . .	30
Power Mode . . . . .	30
Interrupts (nIRQ) . . . . .	30
Watchdog Timer . . . . .	31
Thermal Alarms and Protection . . . . .	32
Register Reset Conditions . . . . .	32
Factory Options . . . . .	32
Detailed Description—Smart Power Selector Charger . . . . .	33
Charger Symbol Reference Guide . . . . .	33
Smart Power Selector . . . . .	34

**TABLE OF CONTENTS (CONTINUED)**

Input Current Limiter . . . . .	34
Minimum Input Voltage Regulation . . . . .	35
Minimum System Voltage Regulation . . . . .	35
Die Temperature Regulation . . . . .	35
Charger State Machine . . . . .	36
Charger Off State . . . . .	36
Prequalification State . . . . .	37
Fast-Charge States . . . . .	37
Top-Off State . . . . .	37
Done State . . . . .	37
Prequalification Timer Fault State . . . . .	37
Fast-Charge Timer Fault State . . . . .	38
Battery Temperature Fault State . . . . .	38
JEITA-Modified States . . . . .	38
Typical Charge Profile . . . . .	38
Charger Applications Information . . . . .	39
Configuring a Valid System Voltage . . . . .	39
CHGIN/SYS/BATT Capacitor Selection . . . . .	39
Detailed Description—Adjustable Thermistor Temperature Monitors . . . . .	40
Thermistor Bias . . . . .	41
Configurable Temperature Thresholds . . . . .	42
Thermistor Applications Information . . . . .	43
Using Different Thermistor $\beta$ . . . . .	43
NTC Thermistor Selection . . . . .	44
Detailed Description—Analog Multiplexer . . . . .	44
Measuring Battery Current . . . . .	45
Method for Measuring Discharging Current . . . . .	45
Method for Measuring Charging Current . . . . .	46
Detailed Description—Linear Regulator . . . . .	46
LDO Enable Control . . . . .	46
LDO Power Mode (PMLDO) . . . . .	47
LDO Power-OK Output (POKLDO) . . . . .	48
LDO Applications Information . . . . .	48
Input/Output Capacitor Selection . . . . .	48
Startup Rate and Inrush Current . . . . .	48
PCB Layout Guidelines . . . . .	49
Detailed Description—Dual-Channel Current Sink Driver . . . . .	50
Detailed Description—I <sup>2</sup> C Serial Interface . . . . .	51
Register Map . . . . .	52

---

**TABLE OF CONTENTS (CONTINUED)**

---

MAX77734 .....	52
Register Details .....	53
Typical Application Circuits .....	70
Battery Charger using LDO Hardware Enable Key .....	70
Battery Charger using LDO Software Enable.....	71
Ordering Information .....	71
Revision History .....	72

---

**LIST OF FIGURES**

---

Figure 1. On/Off Controller State Machine . . . . .	25
Figure 2. On/Off Controller Action Sequences . . . . .	27
Figure 3. nENLDO Dual-Functionality Timing Diagram. . . . .	29
Figure 4. nENLDO Pullup Resistor Configuration . . . . .	30
Figure 5. Watchdog Timer State Machine. . . . .	31
Figure 6. Charger Simplified Control Loops . . . . .	34
Figure 7. Charger State Diagram . . . . .	36
Figure 8. Example Battery Charge Profile. . . . .	39
Figure 9. Thermistor Logic Functional Diagram . . . . .	40
Figure 10. Safe-Charging Profile Example . . . . .	41
Figure 11. Thermistor Bias State Diagram . . . . .	42
Figure 12. Thermistor Circuit with Adjusting Series and Parallel Resistors . . . . .	43
Figure 13. LDO Simplified Block Diagram. . . . .	46
Figure 14. Dynamic LDO Power Mode Control Idea. . . . .	48
Figure 15. PCB Top-Metal and Component Layout Example . . . . .	49
Figure 16. LED Current Sinks Functional Block Diagram . . . . .	50

---

**LIST OF TABLES**

---

Table 1. On/Off Controller Transitions List . . . . .	25
Table 2. On/Off Controller Internal Signals . . . . .	27
Table 3. On/Off Controller State Transition Priority . . . . .	28
Table 4. Watchdog Timer Factory-Programmed Safety Options . . . . .	31
Table 5. Register Reset Conditions . . . . .	32
Table 6. Factory-Programmed Defaults (OTP Options) . . . . .	32
Table 7. Charger Quick Symbol Reference Guide . . . . .	33
Table 8. Input Current Limit Factory Options . . . . .	34
Table 9. Trip Temperatures vs. Trip Voltages for Different NTC $\beta$ . . . . .	42
Table 10. Example $R_S$ and $R_P$ Correcting Values for NTC $\beta$ Above 3380K . . . . .	43
Table 11. NTC Thermistors . . . . .	44
Table 12. AMUX Signal Transfer Functions . . . . .	44
Table 13. Battery Current Direction Decode . . . . .	45
Table 14. LDO Power Mode Truth Table . . . . .	47
Table 15. I <sup>2</sup> C Slave Address Options . . . . .	51

## Absolute Maximum Ratings

nIRQ, POKLDO to GND	-0.3V to $V_{SYS} + 0.3V$	LDO to GND	-0.3V to $V_{INLDO} + 0.3V$
SCL, SDA, PMLDO to GND	-0.3V to $V_{IO} + 0.3V$	INLDO, $V_{IO}$ to GND	-0.3V to $V_{SYS} + 0.3V$
nENLDO to GND (Note 1)	-0.3V to $V_{CCINT} + 0.3V$	SNK1, SNK2 to GND	-0.3V to +6.0V
CHGIN to GND	-0.3V to +30.0V	Operating Temperature Range	-40°C to +85°C
SYS, BATT to GND	-0.3V to +6.0V	Junction Temperature	+150°C
$V_L$ to GND	-0.3V to +6.0V	Storage Temperature Range	-65°C to +150°C
AMUX, THM, TBIAS to GND	-0.3V to +6.0V	Soldering Temperature (reflow)	+260°C
nIRQ, POKLDO Continuous Current	±3mA	Continuous Power Dissipation (70°C ambient)	
SDA, AMUX Continuous Current	±20mA	WLP (derate 18mW/°C above +70°C)	1440mW
CHGIN, SYS, BATT Continuous Current	1.2A <sub>RMS</sub>		

**Note 1:**  $V_{CCINT}$  is internally connected to either BATT or  $V_L$ . Refer to [nENLDO Pullup Resistors to  \$V\_{CCINT}\$  \( \$V\_{CC}\$  Internal\)](#) section.

Stresses beyond those listed under "Absolute Maximum Ratings" may cause permanent damage to the device. These are stress ratings only, and functional operation of the device at these or any other conditions beyond those indicated in the operational sections of the specifications is not implied. Exposure to absolute maximum rating conditions for extended periods may affect device reliability.

## Package Information

### 20WLP

Package Code	N201B2+1
Outline Number	<a href="#">21-100154</a>
Land Pattern Number	Refer to <a href="#">Application Note 1891</a>
<b>THERMAL RESISTANCE, FOUR-LAYER BOARD</b>	
Junction to Ambient ( $\theta_{JA}$ )	55.49 °C/W

For the latest package outline information and land patterns (footprints), go to [www.maximintegrated.com/packages](http://www.maximintegrated.com/packages). Note that a "+", "#", or "-" in the package code indicates RoHS status only. Package drawings may show a different suffix character, but the drawing pertains to the package regardless of RoHS status.

Package thermal resistances were obtained using the method described in JEDEC specification JESD51-7, using a four-layer board. For detailed information on package thermal considerations, refer to [www.maximintegrated.com/thermal-tutorial](http://www.maximintegrated.com/thermal-tutorial).

## Electrical Characteristics

( $V_{CHGIN} = 0V$ ,  $V_{SYS} = V_{BATT} = V_{INLDO} = 3.7V$ ,  $V_{IO} = 1.8V$ , limits are 100% production tested at  $T_A = +25^\circ C$ , limits over the operating temperature range ( $T_A = -40^\circ C$  to  $+85^\circ C$ ) are guaranteed by design and characterization, unless otherwise noted.)

PARAMETER	SYMBOL	CONDITIONS	MIN	TYP	MAX	UNITS
SYS Voltage Range	$V_{SYS}$		2.7		5.5	V
BATT Factory-Ship Mode Current	$I_{BATT-FSM}$	Factory-ship mode (BATT to SYS switch open), $T_A = +25^\circ C$ , $V_{BATT} = 3.7V$ , $V_{SYS} = V_{INLDO} = 0V$		0.2	1	$\mu A$
BATT Shutdown Current	$I_{BATT-SHDN}$	Shutdown state (all resources and bias off), BATT to SYS switch closed, $T_A = +25^\circ C$ , no load		0.5	1	$\mu A$

**Electrical Characteristics (continued)**

( $V_{CHGIN} = 0V$ ,  $V_{SYS} = V_{BATT} = V_{INLDO} = 3.7V$ ,  $V_{IO} = 1.8V$ , limits are 100% production tested at  $T_A = +25^\circ C$ , limits over the operating temperature range ( $T_A = -40^\circ C$  to  $+85^\circ C$ ) are guaranteed by design and characterization, unless otherwise noted.)

PARAMETER	SYMBOL	CONDITIONS		MIN	TYP	MAX	UNITS
BATT Standby Current	$I_{BATT-STDBY}$	Standby state (all resources off), BATT to SYS switch closed, no load	Bias enabled in low-power mode (BIAS_REQ = 1, BIAS_LPM = 1)		1.5		$\mu A$
			Bias enabled in normal mode (BIAS_REQ = 1, BIAS_LPM = 0)		30		
BATT Quiescent Current	$I_{BATT-Q}$	Resource on state, BATT to SYS switch closed, current sinks and analog MUX disabled, $V_{LDO} = 1.2V$ , no load	Bias is in low-power mode (BIAS_LPM = 1), LDO enabled in low-power mode		4.5	10	$\mu A$
			Bias is in low-power mode (BIAS_LPM = 1), LDO enabled in normal mode		22	40	
			Bias is in normal mode (BIAS_LPM = 0), LDO enabled in normal mode		40	60	
<b>POWER-ON RESET (POR)</b>							
POR Threshold	$V_{POR}$	$V_{SYS}$ falling		1.5	1.9	2.1	V
POR Threshold Hysteresis					100		mV
<b>UNDERVOLTAGE LOCKOUT (UVLO)</b>							
UVLO Threshold	$V_{SYSUVLO}$	$V_{SYS}$ falling		2.65	2.85	3.05	V
		$V_{SYS}$ falling. MAX77734M option.		2.35	2.50	2.65	
UVLO Threshold Hysteresis	$V_{SYSUVLO\_HYS}$				150		mV
<b>OVERVOLTAGE LOCKOUT (OVLO)</b>							
OVLO Threshold	$V_{SYSOVLO}$	$V_{SYS}$ rising		5.55	5.85	6.15	V
<b>THERMAL MONITORS</b>							
Over-Temperature Lockout Threshold	$T_{OTLO}$	$T_J$ rising			165		$^\circ C$
Thermal Alarm Temperature 1	$T_{JAL1}$	$T_J$ rising			80		$^\circ C$
Thermal Alarm Temperature 2	$T_{JAL2}$	$T_J$ rising			100		$^\circ C$
Thermal Alarm Temperature Hysteresis					15		$^\circ C$
<b>ENABLE INPUT (nENLDO)</b>							
nENLDO Leakage Current	$I_{nENLDO-LKG}$	$V_{BATT} = 5.5V$ , $V_{nENLDO} = 5.5V$	$T_A = +25^\circ C$	-1	$\pm 0.001$	+1	$\mu A$
			$T_A = +85^\circ C$		$\pm 0.01$		

**Electrical Characteristics (continued)**

( $V_{CHGIN} = 0V$ ,  $V_{SYS} = V_{BATT} = V_{INLDO} = 3.7V$ ,  $V_{IO} = 1.8V$ , limits are 100% production tested at  $T_A = +25^\circ C$ , limits over the operating temperature range ( $T_A = -40^\circ C$  to  $+85^\circ C$ ) are guaranteed by design and characterization, unless otherwise noted.)

PARAMETER	SYMBOL	CONDITIONS		MIN	TYP	MAX	UNITS
nENLDO Falling Threshold	$V_{TH\_nENLDO\_F}$	nENLDO Falling		$V_{CCINT} - 1.4$	$V_{CCINT} - 1.0$		V
nENLDO Rising Threshold	$V_{TH\_nENLDO\_R}$	nENLDO Rising			$V_{CCINT} - 0.9$	$V_{CCINT} - 0.6$	V
$V_{CC}$ Internal	$V_{CCINT}$	(Note 2)	$V_{CHGIN} = 0V$ , battery is present ( $V_{BATT}$ is valid)	$V_{BATT}$			V
			$V_{CHGIN} = 5V$ , not USB suspended ( $USBS = 0$ )	$V_L$			
nENLDO Pullup	$R_{nEN-PU}$	Pullup to $V_{CCINT}$	$PU\_DIS = 0$	200			k $\Omega$
			$PU\_DIS = 1$	10000			
Debounce Time	$t_{DBNC\_nENLDO}$	Rising and falling, not in factory-ship mode	$DB\_nENLDO = 0$ (Note 3)	200			$\mu s$
			$DB\_nENLDO = 1$	30			ms
	$t_{FSM-EXDB}$	Falling only, factory-ship mode (Note 4)	250				
Manual Reset Time	$t_{MRST}$	$T\_MRST = 0$	5	8	10	s	
		$T\_MRST = 1$	10	16	20		
Watchdog Timer Period	$t_{WD}$	$WDT\_PER[1:0] = 0b11$	89	128	154	s	
<b>INTERRUPT OUTPUT (nIRQ)</b>							
nIRQ Output Low Voltage	$V_{nIRQ-LO}$	Sinking 2mA				0.4	V
nIRQ Leakage Current	$I_{nIRQ-LKG}$	$V_{SYS} = V_{IO} = 5.5V$ , nIRQ set to be high impedance (i.e., no interrupts), $V_{nIRQ} = 0V$ and $3.6V$	$T_A = +25^\circ C$	-1	$\pm 0.001$	+1	$\mu A$
			$T_A = +85^\circ C$		$\pm 0.01$		

**Electrical Characteristics—Smart Power Selector Charger**

( $V_{CHGIN} = 5.0V$ ,  $V_{SYS} = 4.5V$ ,  $V_{BATT} = 4.2V$ , limits are 100% production tested at  $T_A = +25^\circ C$ , limits over the operating temperature range ( $T_A = -40^\circ C$  to  $+85^\circ C$ ) are guaranteed by design and characterization, unless otherwise noted.)

PARAMETER	SYMBOL	CONDITIONS	MIN	TYP	MAX	UNITS
<b>DC INPUT</b>						
CHGIN Valid Voltage Range	$V_{CHGIN}$	Initial CHGIN voltage before enabling charging	4.10		7.25	V
CHGIN Standoff Voltage Range	$V_{STANDOFF}$	DC rising		28		V
CHGIN Overvoltage Threshold	$V_{CHGIN\_OVP}$	DC rising	7.25	7.50	7.75	V
CHGIN Overvoltage Hysteresis				100		mV
CHGIN Undervoltage Lockout	$V_{CHGIN\_UVLO}$	DC rising	3.9	4.0	4.1	V

**Electrical Characteristics—Smart Power Selector Charger (continued)**

( $V_{CHGIN} = 5.0V$ ,  $V_{SYS} = 4.5V$ ,  $V_{BATT} = 4.2V$ , limits are 100% production tested at  $T_A = +25^\circ C$ , limits over the operating temperature range ( $T_A = -40^\circ C$  to  $+85^\circ C$ ) are guaranteed by design and characterization, unless otherwise noted.)

PARAMETER	SYMBOL	CONDITIONS	MIN	TYP	MAX	UNITS
CHGIN Undervoltage-Lockout Hysteresis				500		mV
Input Current-Limit Range	$I_{CHGIN-LIM}$	$V_{SYS} = V_{SYS-REG} - 100mV$ , programmable in 95mA steps	95		475	mA
Input Current-Limit Accuracy		$I_{CHGIN-LIM} = 95mA$ , $V_{SYS} = V_{SYS-REG} - 100mV$	90	95	100	mA
Minimum Input Voltage Regulation Range	$V_{CHGIN-MIN}$	$V_{CHGIN}$ falling due to loading conditions and/or high-impedance charge source, programmable in 100mV increments with $V_{CHGIN\_MIN}[2:0]$	4.0		4.7	V
Minimum Input Voltage Regulation Accuracy		$V_{CHGIN-MIN} = 4.5V$ ( $V_{CHGIN\_MIN}[2:0] = 0b101$ ), $I_{CHGIN}$ reduced by 10%	4.32	4.50	4.68	V
Charger Input Debounce Timer	$t_{CHGIN-DB}$	$V_{CHGIN} = 5V$ , time before CHGIN is allowed to deliver current to SYS or BATT	100	120	140	ms
<b>SUPPLY AND QUIESCENT CURRENTS</b>						
CHGIN Supply Current	$I_{CHGIN}$	$V_{CHGIN} = 5V$ , charger is not in USB suspend ( $USBS = 0$ ), charging is finished ( $CHG\_DTLS[3:0]$ indicate done), $I_{SYS} = 0mA$		1.0	1.8	mA
		$V_{CHGIN} = 0V$ to $1V$ , $V_{BATT} = 3.3V$ , $I_{SYS} = 0mA$			50	$\mu A$
CHGIN Suspend Supply Current	$I_{CHGIN-SUS}$	$V_{CHGIN} = 5V$ , charger in USB suspend ( $USBS = 1$ )			50	$\mu A$
BATT Bias Current	$I_{BATT-BIAS}$	$V_{CHGIN} = 5V$ , charger is not in USB suspend ( $USBS = 0$ ), charging is finished ( $CHG\_DTLS[3:0]$ indicate done), $I_{SYS} = 0mA$		5		$\mu A$
<b>PREQUALIFICATION</b>						
Charge Current Soft-Start Slew Time		Zero to full-scale		1		ms
Prequalification Voltage Threshold Range	$V_{PQ}$	Programmable in 100mV steps with $CHG\_PQ[2:0]$	2.3		3.0	V
Prequalification Voltage Threshold Accuracy		$V_{PQ} = 3.0V$	-3		+3	%
Prequalification Mode Charge Current	$I_{PQ}$	$V_{BATT} = 2.5V$ , $V_{PQ} = 3.0V$ , expressed as a percentage of $I_{FAST-CHG}$	$I_{PQ} = 0$	10		%
			$I_{PQ} = 1$	20		
Prequalification Safety Timer	$t_{PQ}$	$V_{BATT} < V_{PQ} = 3.0V$	27	30	33	minutes
<b>FAST-CHARGE</b>						
Fast-Charge Voltage Range	$V_{FAST-CHG}$	$I_{BATT} = 0mA$ , programmable in 25mV steps with $CHG\_CV[5:0]$	3.6		4.6	V

**Electrical Characteristics—Smart Power Selector Charger (continued)**

( $V_{CHGIN} = 5.0V$ ,  $V_{SYS} = 4.5V$ ,  $V_{BATT} = 4.2V$ , limits are 100% production tested at  $T_A = +25^\circ C$ , limits over the operating temperature range ( $T_A = -40^\circ C$  to  $+85^\circ C$ ) are guaranteed by design and characterization, unless otherwise noted.)

PARAMETER	SYMBOL	CONDITIONS	MIN	TYP	MAX	UNITS	
Fast-Charge Voltage Accuracy		$I_{BATT} = 0mA$	$V_{FAST-CHG} = 4.3V$ , $V_{SYS} = 4.5V$ , $T_A = +25^\circ C$	-0.5		+0.5	%
			$V_{FAST-CHG} = 3.6V$ to $4.6V$ , $V_{SYS} = 4.8V$			1.0	
Fast-Charge Current Range	$I_{FAST-CHG}$	Programmable in 7.5mA steps with CHG_CC[5:0]	7.5		300	mA	
Fast-Charge Current Accuracy		$T_A = +25^\circ C$ , $V_{BATT} = V_{FAST-CHG} - 300mV$	$I_{FAST-CHG} = 15mA$	-1.5		+1.5	%
			$I_{FAST-CHG} = 300mA$	-1.5		+1.5	
Fast-Charge Current Accuracy over Temperature		Across all current settings, $V_{BATT} = V_{FAST-CHG} - 300mV$ , $T_A = -40^\circ C$ to $+85^\circ C$	-10		+10	%	
Fast-Charge Safety Timer Range	$t_{FC}$	Programmable in 2 hour increments or disabled with T_FAST_CHG[1:0], time measured from prequal done to timer fault	3		7	hours	
Fast-Charge Safety Timer Accuracy		$t_{FC} = 3$ hours	-10		+10	%	
Fast-Charge Safety Timer Suspend Threshold		Fast-charge CC mode, fast-charge safety timer paused when charge current drops below this threshold, expressed as a percentage of $I_{FAST-CHG}$		20		%	
Junction Temperature Regulation Setting Range	$T_{J-REG}$	Programmable in $10^\circ C$ steps with TJ_REG[2:0]	60		100	$^\circ C$	
Junction Temperature Regulation Loop Gain	$G_{TJ-REG}$	Rate at which $I_{FAST-CHG}/I_{PQ}$ is reduced to maintain $T_{J-REG}$ , expressed as a percentage of $I_{FAST-CHG}/I_{PQ}$ per degree centigrade rise		-5.4		%/ $^\circ C$	
<b>TERMINATION AND TOPOFF</b>							
End-of-Charge Termination Current	$I_{TERM}$	$I_{TERM} = 0b00$ (expressed as a percentage of $I_{FAST-CHG}$ )		5		%	
		$I_{TERM} = 0b01$ (expressed as a percentage of $I_{FAST-CHG}$ )		7.5			
		$I_{TERM} = 0b10$ (expressed as a percentage of $I_{FAST-CHG}$ )	8.5	10	11.5		
		$I_{TERM} = 0b11$ (expressed as a percentage of $I_{FAST-CHG}$ )		15			
Top-Off Timer Range	$t_{TO}$	$I_{BATT} < I_{TERM}$ , programmable in 5 minute steps with T_TOPOFF[2:0]	0		35	minutes	
Top-Off Timer Accuracy		$t_{TO} = 10$ minutes	-10		+10	%	
Charge Restart Threshold	$V_{RESTART}$	Charging is finished (CHG_DTLS[3:0] indicate done), charging resumes when $V_{BATT} < V_{FAST-CHG} - V_{RESTART}$	65	150		mV	

**Electrical Characteristics—Smart Power Selector Charger (continued)**

( $V_{CHGIN} = 5.0V$ ,  $V_{SYS} = 4.5V$ ,  $V_{BATT} = 4.2V$ , limits are 100% production tested at  $T_A = +25^\circ C$ , limits over the operating temperature range ( $T_A = -40^\circ C$  to  $+85^\circ C$ ) are guaranteed by design and characterization, unless otherwise noted.)

PARAMETER	SYMBOL	CONDITIONS	MIN	TYP	MAX	UNITS	
End-of-Charge Termination Current Accuracy		$I_{FAST-CHG} = 15mA$ , $I_{TERM} = 1.5mA$ (10% of $I_{FAST-CHG}$ ), $T_A = +25^\circ C$	1.35	1.5	1.65	mA	
		$I_{FAST-CHG} = 300mA$ , $I_{TERM} = 30mA$ (10% of $I_{FAST-CHG}$ ), $T_A = +25^\circ C$	27	30	33		
End-of-Charge Termination Current Glitch Filter				60		$\mu s$	
<b>DEVICE ON-RESISTANCE AND LEAKAGE</b>							
BATT to SYS On-Resistance		$V_{BATT} = 3.7V$ , $I_{BATT} = 300mA$ , $V_{CHGIN} = 0V$ , battery is discharging to SYS		100	150	m $\Omega$	
Charger FET Leakage Current		$V_{SYS} = 4.5V$ , $V_{BATT} = 0V$ , charger disabled	$T_A = +25^\circ C$	0.1	1.0	$\mu A$	
			$T_A = +85^\circ C$	1			
		$V_{SYS} = 0V$ , $V_{BATT} = 4.2V$ , factory-ship mode	$T_A = +25^\circ C$	0.1	1.0		
			$T_A = +85^\circ C$	1			
CHGIN to SYS On-Resistance		$V_{CHGIN} = 4.65V$ , $I_{CHGIN} = 400mA$		600		m $\Omega$	
Input FET Leakage Current		$V_{CHGIN} = 0V$ , $V_{SYS} = 4.2V$ , body-switched diode reverse biased	$T_A = +25^\circ C$	0.1	1.0	$\mu A$	
			$T_A = +85^\circ C$	1			
<b>SYSTEM NODE</b>							
System Voltage Regulation Range	$V_{SYS-REG}$	Programmable in 25mV steps with $VSYS\_REG[4:0]$	4.1		4.8	V	
System Voltage Regulation Accuracy	$V_{SYS}$	$VSYS-REG = 4.5V$ , $ISYS = 1mA$	$T_A = +25^\circ C$	4.41	4.50	4.59	V
			$T_A = -40^\circ C$ to $+85^\circ C$	4.365	4.5	4.635	
Minimum System Voltage Regulation Loop Setpoint	$V_{SYS-MIN}$	$V_{CHGIN} = 5V$ , $VSYS-REG = 4.5V$ , $V_{SYS} < VSYS-REG$ due to $I_{CHGIN} = I_{CHGIN-LIM}$ (input in current limit), battery charging, $I_{BATT}$ reduced to 50% of $I_{FAST-CHG}$ (minimum system voltage regulation active)	4.34	4.4	4.45	V	
Supplement Mode System Voltage Regulation		$ISYS = 150mA$		$V_{BATT} - 0.15V$		V	

**Electrical Characteristics—Adjustable Thermistor Temperature Monitors**

( $V_{CHGIN} = 5.0V$ ,  $V_{SYS} = 4.5V$ ,  $V_{BATT} = 4.2V$ , limits are 100% production tested at  $T_A = +25^\circ C$ , limits over the operating temperature range ( $T_A = -40^\circ C$  to  $+85^\circ C$ ) are guaranteed by design and characterization, unless otherwise noted.)

PARAMETER	SYMBOL	CONDITIONS	MIN	TYP	MAX	UNITS
<b>JEITA TEMPERATURE MONITORS</b>						
TBIAS Voltage	$V_{TBIAS}$	$THM\_EN = 1$ , $V_{CHGIN} = 5V$		1.25		V

**Electrical Characteristics—Adjustable Thermistor Temperature Monitors (continued)**

( $V_{CHGIN} = 5.0V$ ,  $V_{SYS} = 4.5V$ ,  $V_{BATT} = 4.2V$ , limits are 100% production tested at  $T_A = +25^\circ C$ , limits over the operating temperature range ( $T_A = -40^\circ C$  to  $+85^\circ C$ ) are guaranteed by design and characterization, unless otherwise noted.)

PARAMETER	SYMBOL	CONDITIONS	MIN	TYP	MAX	UNITS
JEITA Cold Threshold Range	$V_{COLD}$	Voltage rising threshold, programmable with THM_COLD[1:0] in 5°C increments when using an NTC $\beta = 3380K$	0.867		1.024	V
JEITA Cool Threshold Range	$V_{COOL}$	Voltage rising threshold, programmable with THM_COOL[1:0] in 5°C increments when using an NTC $\beta = 3380K$	0.747		0.923	V
JEITA Warm Threshold Range	$V_{WARM}$	Voltage falling threshold, programmable with THM_WARM[1:0] in 5°C increments when using an NTC $\beta = 3380K$	0.367		0.511	V
JEITA Hot Threshold Range	$V_{HOT}$	Voltage falling threshold, programmable with THM_HOT[1:0] in 5°C increments when using an NTC $\beta = 3380K$	0.291		0.411	V
Temperature Threshold Accuracy		Voltage threshold accuracy expressed as temperature for an NTC $\beta = 3380K$		±3		°C
Temperature Threshold Hysteresis		Temperature hysteresis set on each voltage threshold for an NTC $\beta = 3380K$		3		°C
JEITA Modified Fast-Charge Voltage Range	$V_{FAST-CHG\_JEITA}$	$I_{BATT} = 0mA$ , programmable in 25mV steps, battery is either cool or warm	3.6		4.6	V
JEITA Modified Fast-Charge Current Range	$I_{FAST-CHG\_JEITA}$	Programmable in 7.5mA steps, battery is either cool or warm	7.5		300	mA

**Electrical Characteristics—Analog Multiplexer**

( $V_{CHGIN} = 5.0V$ ,  $V_{SYS} = 4.5V$ ,  $V_{BATT} = 4.2V$ , limits are 100% production tested at  $T_A = +25^\circ C$ , limits over the operating temperature range ( $T_A = -40^\circ C$  to  $+85^\circ C$ ) are guaranteed by design and characterization, unless otherwise noted.)

PARAMETER	SYMBOL	CONDITIONS	MIN	TYP	MAX	UNITS
<b>ANALOG MULTIPLEXER</b>						
Full-Scale Voltage	$V_{FS}$			1.25		V
Channel Switching Time				0.3		μs
Off Leakage Current		$V_{AMUX} = 0V$ , AMUX is high impedance	$T_A = +25^\circ C$	1	500	nA
			$T_A = +85^\circ C$	1		μA
<b>CHGIN POWER MEASUREMENT</b>						
CHGIN Current Monitor Gain	$G_{I_{CHGIN}}$	$V_{FS}$ corresponds to maximum $I_{CHGIN-LIM}$ setting		2.632		V/A
CHGIN Voltage Monitor Gain	$G_{V_{CHGIN}}$	$V_{FS}$ corresponds to $V_{CHGIN\_OVP}$		0.167		V/V
<b>BATT AND SYS POWER MEASUREMENT</b>						
Battery Charge Current Monitor Gain	$G_{I_{BATT-CHG}}$	$V_{FS}$ corresponds to 100% of $I_{FAST-CHG}$ setting (CHG_CC[5:0])		12.5		mV/%
Charge Current Monitor Accuracy		$I_{FAST-CHG} = 15mA$ , $T_A = +25^\circ C$ , $V_{BATT} = V_{FAST-CHG} - 300mV$	-3.5		+3.5	%
		$I_{FAST-CHG} = 300mA$ , $T_A = +25^\circ C$ , $V_{BATT} = V_{FAST-CHG} - 300mV$	-3.5		+3.5	

**Electrical Characteristics—Analog Multiplexer (continued)**

( $V_{CHGIN} = 5.0V$ ,  $V_{SYS} = 4.5V$ ,  $V_{BATT} = 4.2V$ , limits are 100% production tested at  $T_A = +25^\circ C$ , limits over the operating temperature range ( $T_A = -40^\circ C$  to  $+85^\circ C$ ) are guaranteed by design and characterization, unless otherwise noted.)

PARAMETER	SYMBOL	CONDITIONS	MIN	TYP	MAX	UNITS
Charge Current Monitor Accuracy over Temperature		Across all current settings, $V_{BATT} = V_{FAST-CHG} - 300mV$	-10		+10	%
Battery Discharge Monitor Full-Scale Current Range	$I_{DISCHG-SCALE}$	Programmable with $IMON\_DISCHG\_SCALE[3:0]$	8.2		300	mA
Battery Discharge Current Monitor Accuracy		15mA to 300mA battery discharge current, $I_{DISCHG-SCALE} = 300mA$	-15		+15	%
Battery Discharge Current Monitor Offset		$I_{BATT} = 0mA$	-0.5		+0.8	mA
Battery-Voltage Monitor Gain	$G_{VBATT}$	$V_{FS}$ corresponds to maximum $V_{FAST-CHG}$ setting		0.272		V/V
SYS Voltage Monitor Gain	$G_{VSYS}$	$V_{FS}$ corresponds to maximum $V_{SYS-REG}$ setting		0.26		V/V
<b>THM AND TBIAS VOLTAGE MEASUREMENT</b>						
THM Voltage Monitor Gain	$G_{VTHM}$			1		V/V
TBIAS Voltage Monitor Gain	$G_{VTBIAS}$			1		V/V

**Electrical Characteristics—Linear Regulator**

( $V_{SYS} = V_{INLDO} = 3.7V$ ,  $C_{SYS} = 22\mu F$ ,  $C_{LDO} = 2.2\mu F$ , limits are 100% production tested at  $T_A = +25^\circ C$ , limits over the operating temperature range ( $T_A = -40^\circ C$  to  $+85^\circ C$ ) are guaranteed by design and characterization, unless otherwise noted. )

PARAMETER	SYMBOL	CONDITIONS	MIN	TYP	MAX	UNITS	
<b>LDO</b>							
INLDO Voltage Range	$V_{INLDO}$	INLDO cannot exceed $V_{SYS}$ by 0.3V	1.7		5.5	V	
INLDO Supply Current	$I_{INLDO-Q}$	$V_{LDO} = 1.2V$ , no load	Low-power mode			$\mu A$	
			Normal mode		12		
LDO Output Voltage Range	$V_{LDO-REG}$	Target regulation voltage. Programmable in 25mV steps with $LDO\_VREG[6:0]$ .	0.8		3.975	V	
LDO Output Voltage Accuracy	$V_{LDO}$	$V_{INLDO} = V_{LDO} + 0.3V$ to 5.5V, across all $V_{LDO-REG}$ settings, bias in normal mode	$I_{LDO} = 0.1mA$ to 150mA, $T_A = -5^\circ C$ to $+85^\circ C$ , normal mode		-2	+2	%
			$I_{LDO} = 0.1mA$ to 150mA, $T_A = -40^\circ C$ , normal mode		-3	+3	
			$I_{LDO} = 0.1mA$ to 5mA, low-power mode		-6.5	+6.5	
LDO Maximum Output Current	$I_{LDO}$	Normal mode (Note 7)			150	mA	
		Low-power mode (Note 7)			5		

**Electrical Characteristics—Linear Regulator (continued)**

( $V_{SYS} = V_{INLDO} = 3.7V$ ,  $C_{SYS} = 22\mu F$ ,  $C_{LDO} = 2.2\mu F$ , limits are 100% production tested at  $T_A = +25^\circ C$ , limits over the operating temperature range ( $T_A = -40^\circ C$  to  $+85^\circ C$ ) are guaranteed by design and characterization, unless otherwise noted. )

PARAMETER	SYMBOL	CONDITIONS		MIN	TYP	MAX	UNITS
Load Regulation		$V_{INLDO} = V_{LDO} + 0.3V$ to $5.5V$ , across all $V_{LDO-REG}$ settings	$I_{LDO} = 0.1mA$ to $150mA$ , normal mode		0.5		%
			$I_{LDO} = 0.1mA$ to $5mA$ , low-power mode		0.5		
Line Regulation		$I_{LDO} = 0.1mA$ , $V_{INLDO} = V_{LDO} + 0.3V$ to $5.5V$ , across all $V_{LDO-REG}$ settings	Normal mode		0.05		%/ $V$
			Low-power mode		0.05		
Dropout Voltage	$V_{DO}$	$I_{LDO} = 150mA$ , normal mode (Note 6)	$V_{INLDO} = 3.0V$ , $V_{LDO-REG} = 3.3V$		60	150	mV
			$V_{INLDO} = 1.7V$ , $V_{LDO-REG} = 1.85V$		100		
LDO Current Limit	$I_{LDO-LIM}$	$V_{LDO} = 90%$ of programmed target	Normal mode	160	300	560	mA
			Low-power mode		40		
LDO Output Capacitance for Stability	$C_{LDO}$	(Note 5)		1.1	2.2		$\mu F$
LDO Startup Ramp Rate	$\Delta V_{LDO}/\Delta t$	10% to 90% of final value			20		mV/ $\mu s$
Output Noise		LDO and bias in normal mode, $f = 10Hz$ to $100kHz$ , $I_{LDO} = 15mA$	$V_{SYS} = V_{INLDO} = 2.7V$ , $V_{LDO} = 0.8V$		100		$\mu V_{RMS}$
			$V_{SYS} = V_{INLDO} = 2.7V$ , $V_{LDO} = 1.0V$		150		
			$V_{SYS} = V_{INLDO} = 2.7V$ , $V_{LDO} = 2.0V$		200		
			$V_{SYS} = V_{INLDO} = 3.7V$ , $V_{LDO} = 3.0V$		300		
			$V_{SYS} = V_{INLDO} = 5.5V$ , $V_{LDO} = 3.975V$		400		
Power-Supply Rejection Ratio	PSRR	LDO in normal-power mode, bias in low-power mode, $V_{SYS} = 3.6V$ , $V_{INLDO} = 2.8V + 20mV_{pp}$ , $f = 10Hz$ to $1kHz$ , $V_{LDO} = 1.8V$ , $I_{LDO} = 15mA$		60			dB
Active Discharge Resistance	$R_{AD\_LDO}$			100			$\Omega$
<b>LDO POWER-OK OUTPUT (POKLDO)</b>							
POKLDO Threshold	$V_{POKLDO\_R}$	$V_{LDO}$ rising, expressed as a percentage of $V_{LDO-REG}$	82.5	87.5	92.5		%
	$V_{POKLDO\_F}$	$V_{LDO}$ falling, expressed as a percentage of $V_{LDO-REG}$	79	84	89		
POKLDO Low Voltage	$V_{POKLDO}$	POKLDO = low, sinking $2mA$			0.4		V

**Electrical Characteristics—Linear Regulator (continued)**

( $V_{SYS} = V_{INLDO} = 3.7V$ ,  $C_{SYS} = 22\mu F$ ,  $C_{LDO} = 2.2\mu F$ , limits are 100% production tested at  $T_A = +25^\circ C$ , limits over the operating temperature range ( $T_A = -40^\circ C$  to  $+85^\circ C$ ) are guaranteed by design and characterization, unless otherwise noted.)

PARAMETER	SYMBOL	CONDITIONS		MIN	TYP	MAX	UNITS
POKLDO Leakage Current	$I_{POKLDO-LKG}$	$V_{SYS} = V_{IO} = 5.5V$ , POKLDO is high-Z, $V_{POKLDO} = 0V$ or 5.5V	$T_A = +25^\circ C$	-1	$\pm 0.001$	+1	$\mu A$
			$T_A = +85^\circ C$			$\pm 0.01$	
<b>LDO POWER-MODE INPUT (PMLDO)</b>							
PMLDO Logic-High Threshold	$V_{PMLDO\_HI}$			$0.7 \times V_{IO}$			V
PMLDO Logic-Low Threshold	$V_{PMLDO\_LO}$			$0.3 \times V_{IO}$			V
PMLDO Debounce Timer	$t_{PMLDO-DB}$	(Note 3)		200			$\mu s$
PMLDO Leakage Current	$I_{PMLDO-LKG}$	$V_{SYS} = V_{IO} = 5.5V$ , $V_{PMLDO} = 0V$ or 5.5V	$T_A = +25^\circ C$	-1	$\pm 0.001$	+1	$\mu A$
			$T_A = +85^\circ C$			$\pm 0.01$	

**Electrical Characteristics—Dual-Channel Current Sink Driver**

( $V_{SYS} = 3.7V$ ,  $V_{SNKx} = 0.2V$ , limits are 100% production tested at  $T_A = +25^\circ C$ , limits over the operating temperature range ( $T_A = -40^\circ C$  to  $+85^\circ C$ ) are guaranteed by design and characterization, unless otherwise noted.)

PARAMETER	SYMBOL	CONDITIONS		MIN	TYP	MAX	UNITS
<b>DUAL-CHANNEL CURRENT SINK DRIVER</b>							
Current Sink Quiescent Current	$\Delta I_{BATT-Q}$	Change in supply current when one channel is enabled and delivering 12.8mA, $V_{SNKx} = 0.2V$			6		$\mu A$
Current Sink Leakage		All current sink drivers combined, outputs disabled, $V_{SNKx} = 5.5V$ ,	$T_A = +25^\circ C$		+0.1	+1.0	$\mu A$
			$T_A = +85^\circ C$			+1.0	
Sink Current Range	$I_{SNKx}$	Programmable with BRT_SNKx[4:0]	SNK_FSx[1:0] = 0b01	0.1		3.2	mA
			SNK_FSx[1:0] = 0b10	0.2		6.4	
			SNK_FSx[1:0] = 0b11	0.4		12.8	
<b>3.2mA CURRENT SINK RANGE (SNK_FSx[1:0]=0b01)</b>							
Current Sink DAC Bits					5		bits
Current Sink Accuracy		BRT_SNKx[4:0] = 0b11111	SNK_FSx[1:0] = 0b01, $T_A = +25^\circ C$	3.10	3.20	3.25	mA
			SNK_FSx[1:0] = 0b01, $T_A = -40^\circ C$ to $+85^\circ C$	2.975	3.20	3.425	
Dropout Voltage	$V_{DO}$	BRT_SNKx[4:0] = 0b11111	SNK_FSx[1:0] = 0b01, $I_{SNKx} = 2.9mA$		35	70	mV

**Electrical Characteristics—Dual-Channel Current Sink Driver (continued)**

( $V_{SYS} = 3.7V$ ,  $V_{SNKx} = 0.2V$ , limits are 100% production tested at  $T_A = +25^\circ C$ , limits over the operating temperature range ( $T_A = -40^\circ C$  to  $+85^\circ C$ ) are guaranteed by design and characterization, unless otherwise noted.)

PARAMETER	SYMBOL	CONDITIONS	MIN	TYP	MAX	UNITS	
<b>6.4mA CURRENT SINK RANGE (SNK_FSx[1:0]=0b10)</b>							
Current Sink Accuracy		BRT_SNKx[4:0] = 0b11111	SNK_FSx[1:0] = 0b10, $T_A = +25^\circ C$	6.30	6.40	6.50	mA
			SNK_FSx[1:0] = 0b10, $T_A = -40^\circ C$ to $+85^\circ C$	5.95	6.40	6.85	
Dropout Voltage	$V_{DO}$	BRT_SNKx[4:0] = 0b11111	SNK_FSx[1:0] = 0b10, $I_{SNKx} = 5.75mA$		35	70	mV
<b>12.8mA CURRENT SINK RANGE (SNK_FSx[1:0]=0b11)</b>							
Current Sink Accuracy		BRT_SNKx[4:0] = 0b11111	SNK_FSx[1:0] = 0b11, $T_A = +25^\circ C$	12.6	12.8	13.0	mA
			SNK_FSx[1:0] = 0b11, $T_A = -40^\circ C$ to $+85^\circ C$	11.9	12.8	13.7	
Dropout Voltage	$V_{DO}$	BRT_SNKx[4:0] = 0b11111	SNK_FSx[1:0] = 0b11, $I_{SNKx} = 11.5mA$		35	70	mV
<b>TIMING CHARACTERISTICS</b>							
Root Clock Frequency			25.6	32.0	38.4	Hz	
<b>TIMING CHARACTERISTICS / BLINK PERIOD SETTINGS</b>							
Minimum Blink Period		P_SNKx[3:0] = 0b0000			0.5	s	
					16	clocks	
Maximum Blink Period		P_SNKx[3:0] = 0b1111			8	s	
					256	clocks	
Blink Period LSB					0.5	s	
					16	clocks	
<b>TIMING CHARACTERISTICS / BLINK DUTY CYCLE</b>							
Minimum Blink Duty Cycle		D_SNKx[3:0] = 0b0000			6.25	%	
Maximum Blink Duty Cycle		D_SNKx[3:0] = 0b1111			100	%	
Blink Duty Cycle LSB					6.25	%	

**Electrical Characteristics—I<sup>2</sup>C Serial Interface**

( $V_{SYS} = 3.7V$ ,  $V_{IO} = 1.8V$ , limits are 100% production tested at  $T_A = +25^\circ C$ , limits over the operating temperature range ( $T_A = -40^\circ C$  to  $+85^\circ C$ ) are guaranteed by design and characterization, unless otherwise noted.)

PARAMETER	SYMBOL	CONDITIONS	MIN	TYP	MAX	UNITS
<b>SERIAL INTERFACE / I/O STAGE</b>						
$V_{IO}$ Voltage Range	$V_{IO}$		1.7		3.6	V
$V_{IO}$ Bias Current		$T_A = +25^\circ C$	-1	0	+1	$\mu A$

**Electrical Characteristics—I<sup>2</sup>C Serial Interface (continued)**

(V<sub>SYS</sub> = 3.7V, V<sub>IO</sub> = 1.8V, limits are 100% production tested at T<sub>A</sub> = +25°C, limits over the operating temperature range (T<sub>A</sub> = -40°C to +85°C) are guaranteed by design and characterization, unless otherwise noted.)

PARAMETER	SYMBOL	CONDITIONS	MIN	TYP	MAX	UNITS
SCL, SDA Input High Voltage	V <sub>IH</sub>		0.7 x V <sub>IO</sub>			V
SCL, SDA Input Low Voltage	V <sub>IL</sub>				0.3 x V <sub>IO</sub>	V
SCL, SDA Input Hysteresis	V <sub>HYS</sub>			0.05 x V <sub>IO</sub>		V
SCL, SDA Input Leakage Current	I <sub>I</sub>	V <sub>IO</sub> = 3.6V, V <sub>SCL</sub> = V <sub>SDA</sub> = 0V or 3.6V	-10		10	μA
SDA Output Low Voltage	V <sub>OL</sub>	Sinking 20mA			0.4	V
SCL, SDA Pin Capacitance		(Note 8)		10		pF
Input Filter Suppressed Spike Maximum Pulse Width	t <sub>SP</sub>	(Note 8)		50		ns
<b>SERIAL INTERFACE / TIMING</b>						
Clock Frequency	f <sub>SCL</sub>				1	MHz
Bus Free Time between STOP and START Condition	t <sub>BUF</sub>		0.5			μs
Setup Time REPEATED START Condition	t <sub>SU;STA</sub>		260			ns
Hold Time REPEATED START Condition	t <sub>HD;STA</sub>		260			ns
SCL Low Period	t <sub>LOW</sub>		500			ns
SCL High Period	t <sub>HIGH</sub>		260			ns
Data Setup Time	t <sub>SU;DAT</sub>		50			ns
Data Hold Time	t <sub>HD;DAT</sub>		0			μs
Setup Time for STOP Condition	t <sub>SU;STO</sub>		260			ns

**Note 2:** See the [nENLDO Pullup Resistors to V<sub>CCINT</sub> \(V<sub>CC</sub> Internal\)](#) section of the data sheet.

**Note 3:** Digitally debounced for two consecutive 100μs clock periods. Typical debounce time is at least 200μs and up to 300μs due to synchronization to the digital clock.

**Note 4:** This is the amount of additional debounce time required to exit factory-ship mode (250ms, typ additional time).

**Note 5:** For stability, guaranteed by design and not production tested.

**Note 6:** The dropout voltage is the difference between the input voltage and the output voltage when the input voltage is within the valid input voltage range, but below the output voltage setpoint. For example, if the output voltage setpoint is 1.85V, the input voltage is 1.7V, and the actual output voltage is 1.65V, then the dropout voltage is 50mV (V<sub>DO</sub> = V<sub>INLDO</sub> - V<sub>LDO</sub>).

**Note 7:** The "Maximum Output Current" is guaranteed by the "Output Voltage Accuracy" tests.

**Note 8:** Design guidance only. Not production tested.

Typical Operating Characteristics

(Typical Application Circuit,  $V_{CHGIN} = 0V$ ,  $V_{SYS} = V_{BATT} = V_{INLDO} = 3.7V$ ,  $V_{IO} = 1.8V$ ,  $T_A = +25^\circ C$ , unless otherwise noted.)

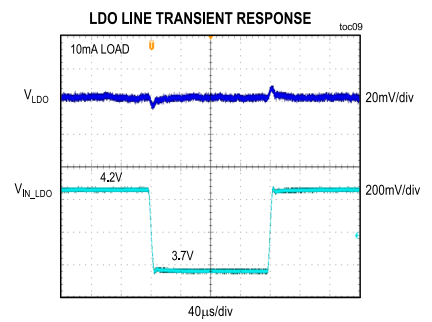
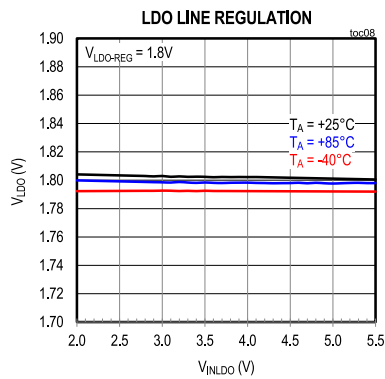
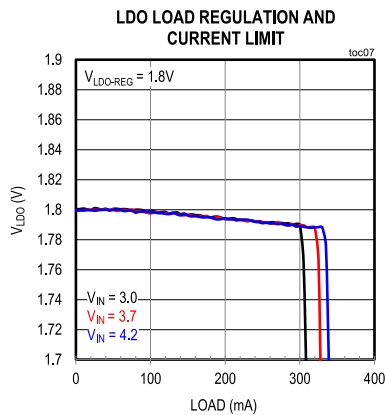
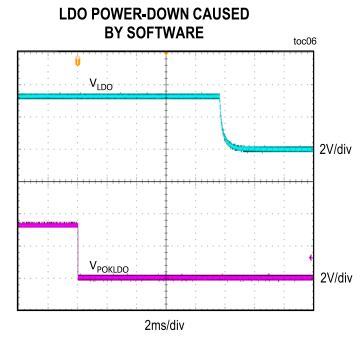
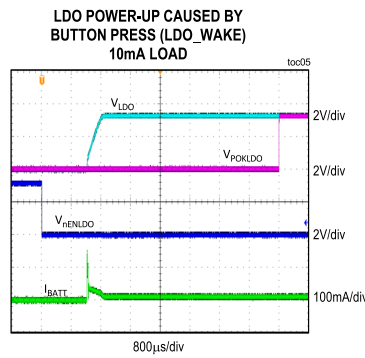
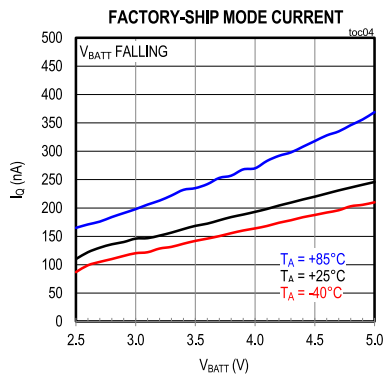
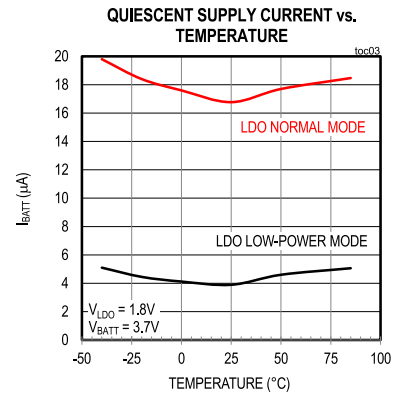
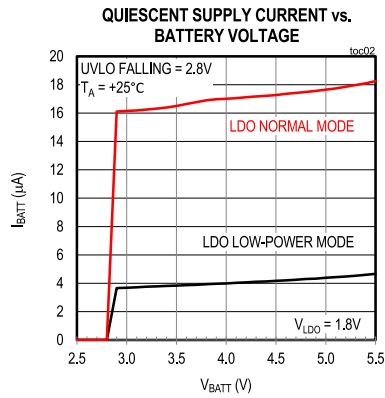
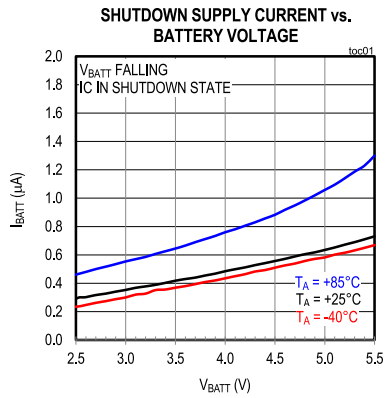

Typical Operating Characteristics (continued)

(Typical Application Circuit,  $V_{CHGIN} = 0V$ ,  $V_{SYS} = V_{BATT} = V_{INLDO} = 3.7V$ ,  $V_{IO} = 1.8V$ ,  $T_A = +25^\circ C$ , unless otherwise noted.)

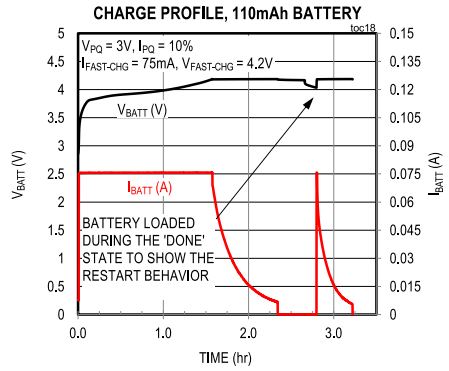
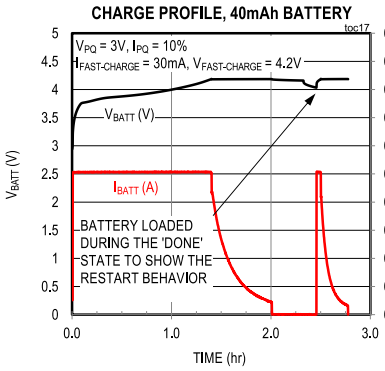
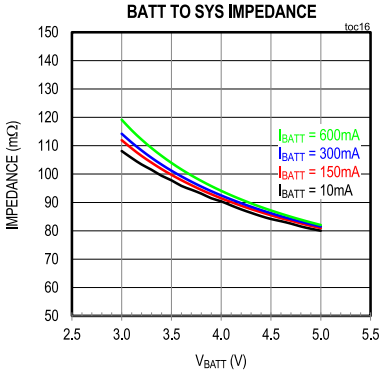
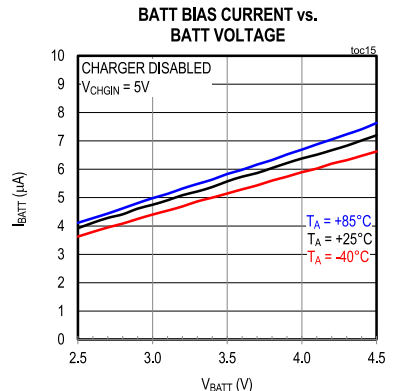
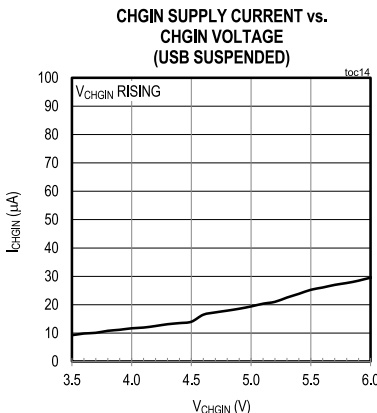
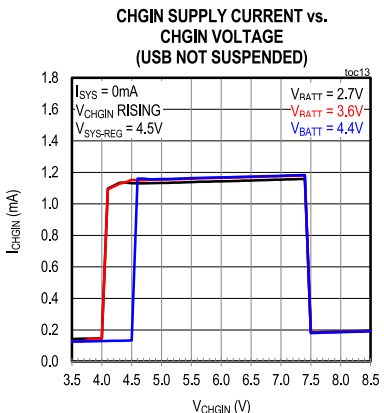
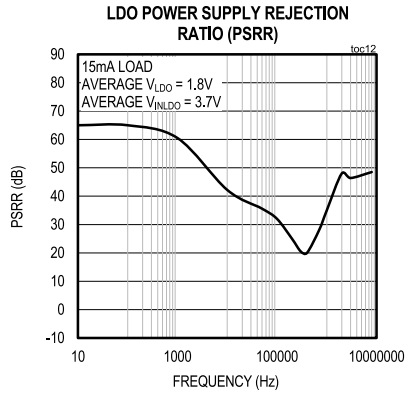
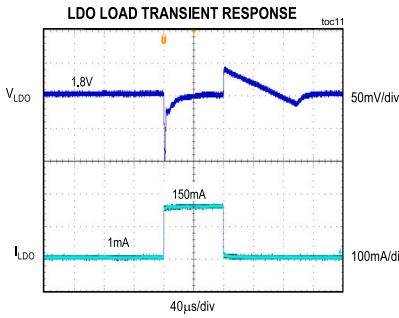
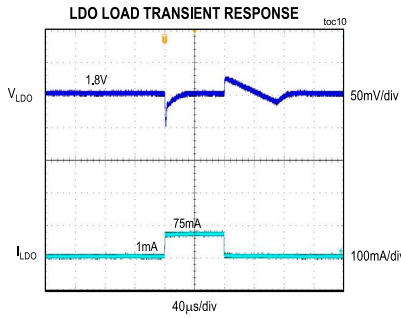

Pin Configuration

MAX77734

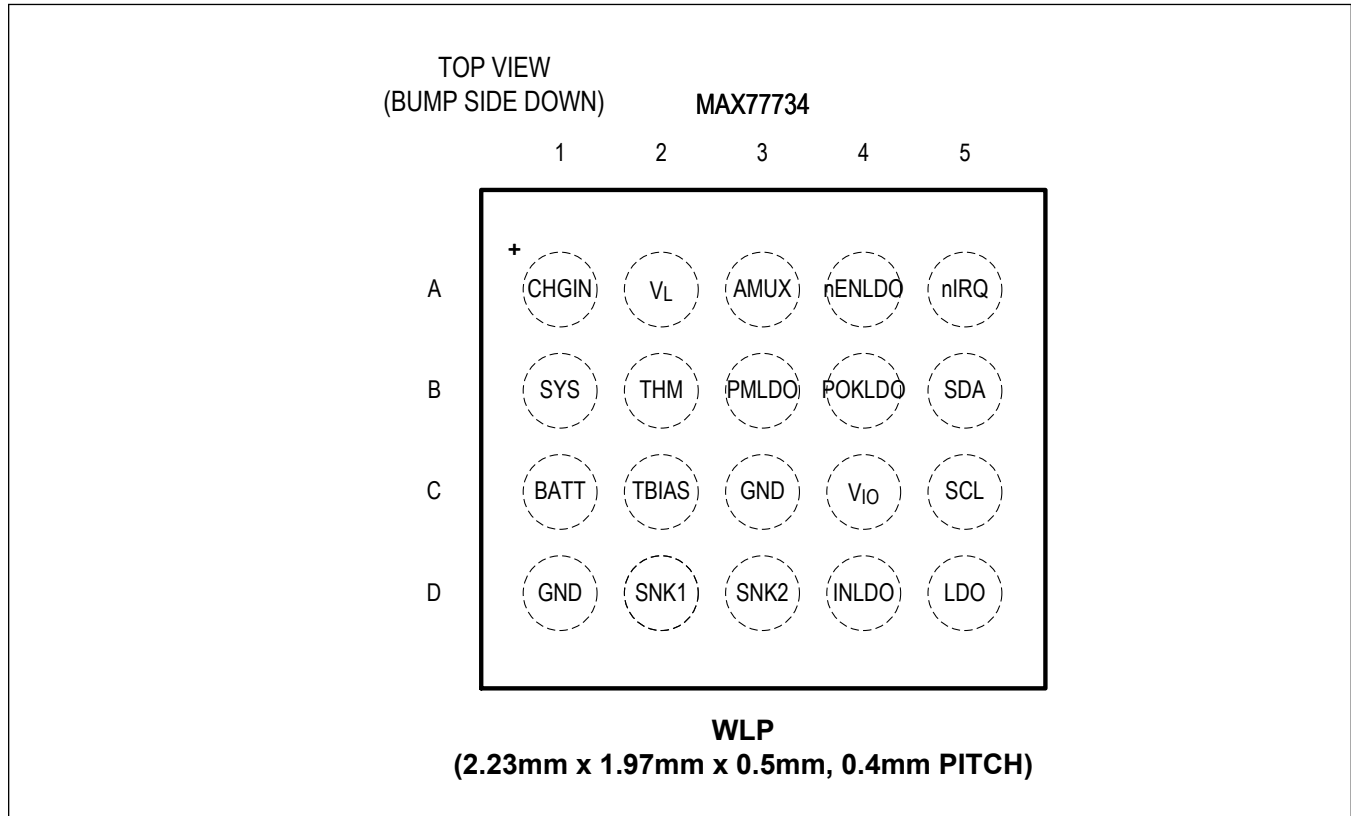

Pin Description

PIN	NAME	FUNCTION	TYPE
<b>CHARGER</b>			
A1	CHGIN	Charger Input. Connect to a 5V DC charging source. Bypass to GND with a 4.7µF ceramic capacitor.	power input
A2	VL	Internal Charger 3V Logic Supply Powered from CHGIN. Bypass to GND with a 1µF ceramic capacitor. Do not load VL externally.	power
A3	AMUX	Analog Multiplexer Output. Connect to system ADC to perform conversions on charger power signals. Leave this pin unconnected if unused.	analog output
B1	SYS	System Power Output. SYS provides power to the system resources as well as the control logic of the IC. Bypass to GND with a 22µF ceramic capacitor.	power output
B2	THM	Thermistor Monitor. Thermally couple an NTC to the battery and connect between THM and GND.	analog input
C1	BATT	Li+ Battery Connection. Connect to positive battery terminal. Bypass to GND with a 4.7µF ceramic capacitor.	power i/o
C2	TBIAS	Thermistor Bias Supply. Connect a resistor equal to the NTC's room temperature resistance between TBIAS and THM. Do not load TBIAS with other external circuitry.	analog

## Pin Description (continued)

PIN	NAME	FUNCTION	TYPE
C3, D1	GND	Ground. Connect to the negative battery terminal and the low-impedance ground plane of the PCB.	ground
<b>LINEAR REGULATOR</b>			
A4	nENLDO	Active-Low LDO Enable Input. This digital input also causes the IC to exit factory-ship mode. Pulled up internally to $V_{CCINT}$ . See the <a href="#">Hardware Enable (nENLDO)</a> section.	digital input
B3	PMLDO	LDO Power-Mode Control Input. This digital input causes the LDO to change between low-power mode and normal mode when the MSB of LDO_PM[1:0] is set. See the <a href="#">LDO Power Mode (PMLDO)</a> section.	digital input
B4	POKLDO	Open-Drain Linear Regulator Power-OK Output. Connect a 100k $\Omega$ pullup resistor between POKLDO and a voltage equal to or less than $V_{SYS}$ if this pin is used. Leave unconnected if unused.	digital output
D4	INLDO	Linear Regulator Input. Connect to GND if unused.	power input
D5	LDO	Linear Regulator Output. Bypass to GND with a 2.2 $\mu$ F ceramic capacitor. Leave unconnected if unused.	power output
<b>DUAL-CHANNEL CURRENT SINK</b>			
D2	SNK1	Current Sink Port 1. SNK1 is typically connected to the cathode of an LED and is capable of sinking up to 12.8mA. Connect to GND if unused.	power
D3	SNK2	Current Sink Port 2. SNK2 is typically connected to the cathode of an LED and is capable of sinking up to 12.8mA. Connect to GND if unused.	power
<b>I<sup>2</sup>C SERIAL INTERFACE</b>			
A5	nIRQ	Active-Low, Open-Drain Interrupt Output. Connect a 100k $\Omega$ pullup resistor between nIRQ and a voltage equal to or less than $V_{SYS}$ .	digital output
B5	SDA	I <sup>2</sup> C Serial Interface Data	digital i/o
C4	V <sub>IO</sub>	I <sup>2</sup> C Serial Interface Voltage Supply	power input
C5	SCL	I <sup>2</sup> C Serial Interface Clock	digital input

Simplified Block Diagram

MAX77734

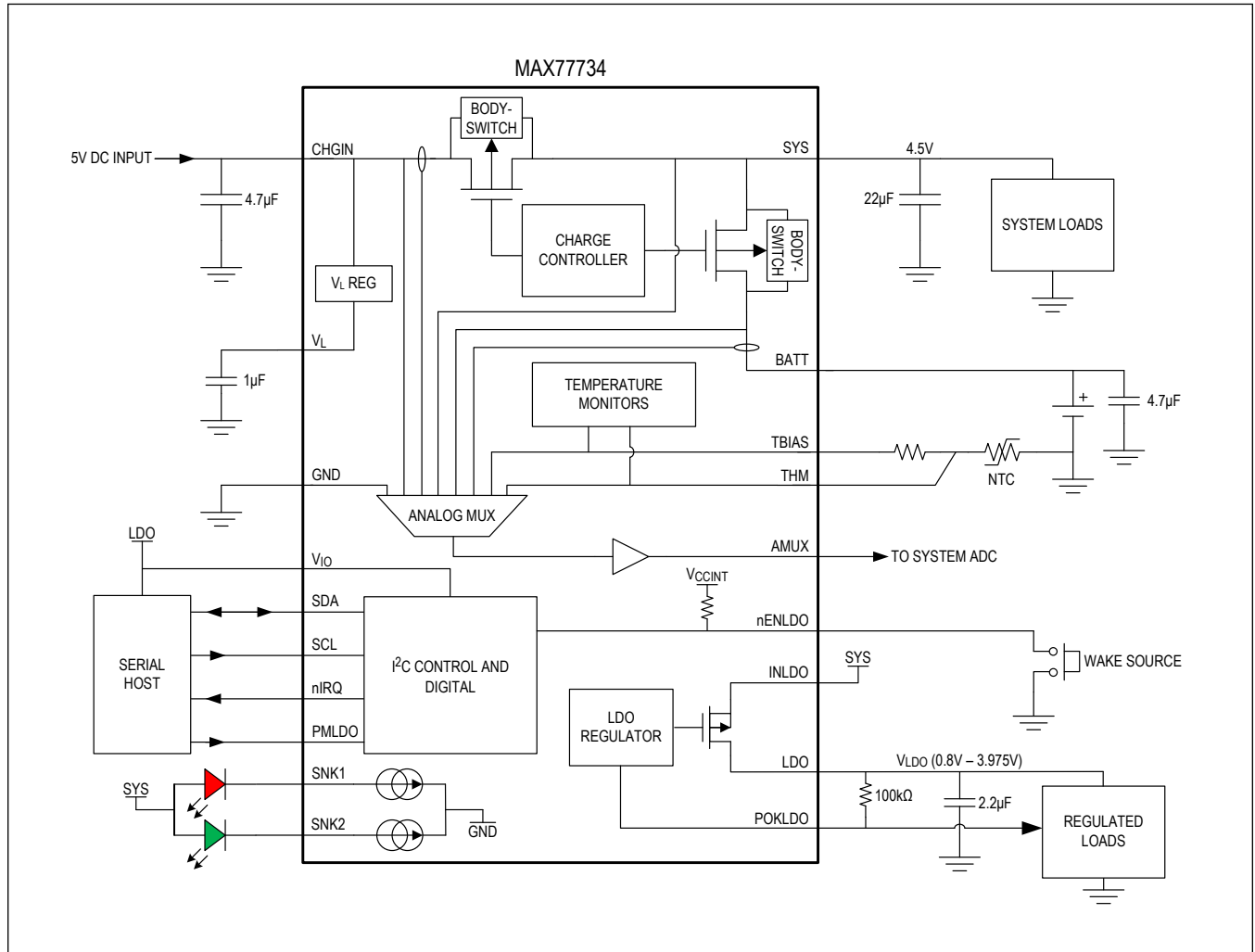

## Detailed Description

The MAX77734 is a tiny power-management integrated circuit (PMIC) that integrates the following:

- Instant-on linear-mode lithium-ion/lithium-polymer (Li+) battery charger optimized for small battery cells (see [Detailed Description-Smart Power Selector Charger](#))
- NTC thermistor monitor for automatic JEITA safe-charging (see [Detailed Description-Adjustable Thermistor Temperature Monitors](#))
- Analog Multiplexer (MUX) which enables an external ADC to monitor power (see [Detailed Description-Analog Multiplexer](#))
- 150mA linear regulator (see [Detailed Description-Linear Regulator](#))
- Dual-channel current sinks with individual pattern control (see [Detailed Description-Dual-Channel Current Sink Driver](#))

The IC's internal top-level digital logic is described in the [On/Off Controller](#) section of the datasheet. The IC is fully configurable through I<sup>2</sup>C (see the [Register Map](#) and [Detailed Description-I<sup>2</sup>C Serial Interface](#)). The active-low nENLDO input can be used to wake-up the LDO using an external on-key. See [Hardware Enable \(nENLDO\)](#).

A low-I<sub>Q</sub> (0.2μA typ) factory-ship mode can be entered to isolate the battery node (BATT) from the system (SYS) to prevent slow cell discharge due to a high combined shutdown current of all external SYS loads (see [Factory-Ship Mode State](#)).

A watchdog timer can be enabled through I<sup>2</sup>C (or factory-enabled and locked) to provide supervisory reset in the event that serial activity from the host controller suddenly stops (see [Watchdog Timer](#)).

Additionally, a SYS voltage supervisory function is accomplished by the undervoltage (UVLO), overvoltage (OVLO), and power-on reset (POR) comparators.

### On/Off Controller

The IC top-level on/off controller uses a synchronous digital state machine with a 100μs clock. Asynchronous inputs to the state machine can take up to 100μs to take effect due to clock synchronization.

The state machine is drawn in [Figure 1](#) and [Figure 2](#). State transition conditions are listed in [Table 1](#).

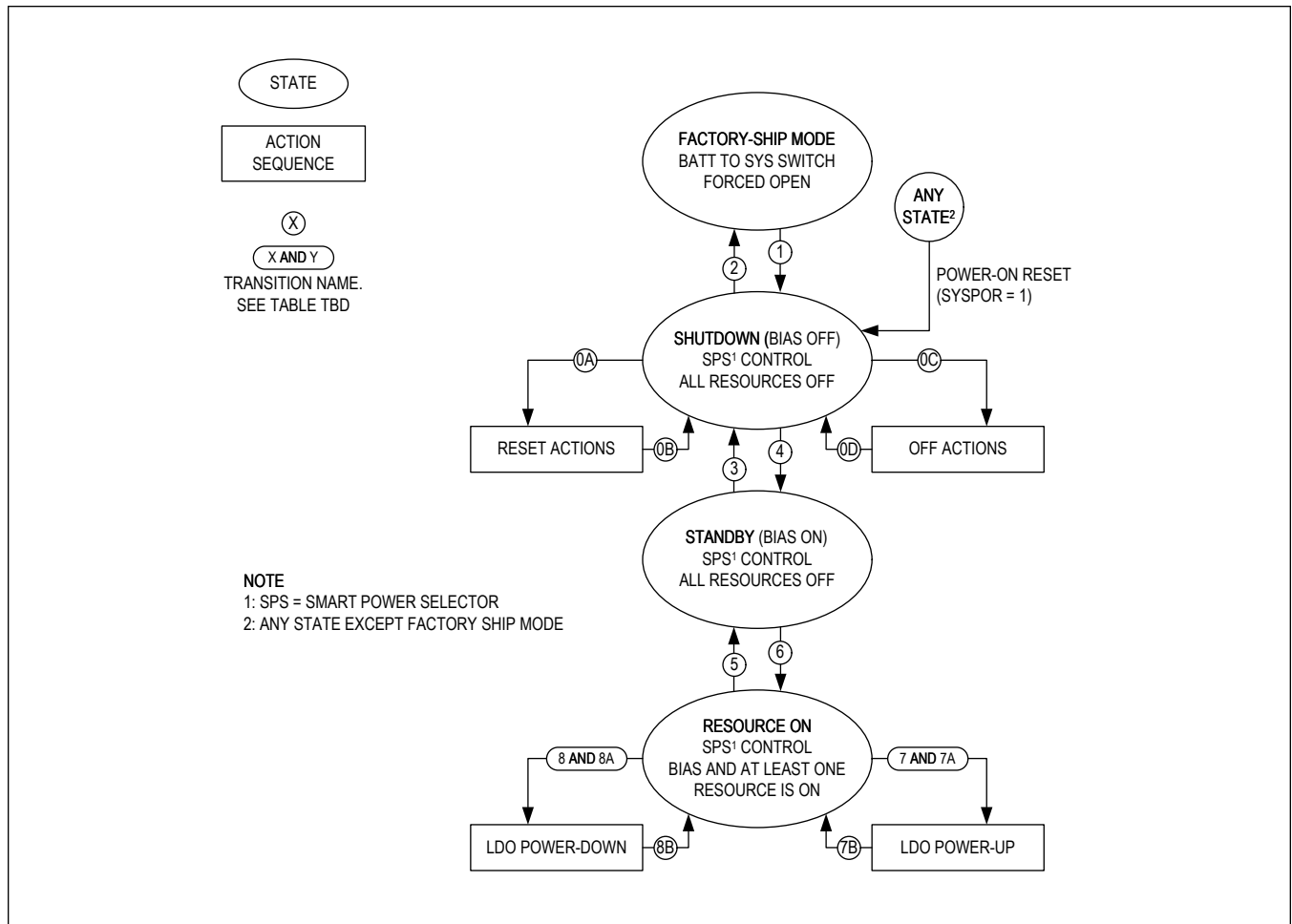

Figure 1. On/Off Controller State Machine

Table 1. On/Off Controller Transitions List

TRANSITION NUMBER	CONDITION (TRANSITION HAPPENS WHEN...)
0A	Software cold reset (SFT_CTRL[1:0] = 0b01) OR Watchdog timer expired causes reset (WDT_EXP = 1 and WDT_MODE = 1)
0B	Reset actions completed
0C	Software power-off (SFT_CTRL[1:0] = 0b10) OR Watchdog expired causes power-off (WDT_EXP = 1 and WDT_MODE = 0) OR Chip over-temperature lockout ( $T_J > T_{OTLO}$ ) OR SYS undervoltage lockout ( $V_{SYS} < V_{SYSUVLO} + V_{SYSUVLO\_HYS}$ ) OR SYS overvoltage lockout ( $V_{SYS} > V_{SYSOVLO}$ ) OR Manual reset occurred (MAN_RST = 1)
0D	Off Actions completed
1	CHGIN inserted and debounced valid (CHGIN_DTLS[1:0] = 0b11) OR nENLDO asserted for 250ms debounce timer ( $t_{FSM-DB}$ ) OR Power to the IC is removed ( $V_{BATT} < \text{approx. } 1.8V$ ) and then reapplied ( $V_{BATT} > V_{POR}$ )
2	Factory-ship mode requested (SFT_CTRL[1:0] = 0b11) AND CHGIN unplugged (CHGIN_DTLS[1:0] = 0b00)

**Table 1. On/Off Controller Transitions List (continued)**

TRANSITION NUMBER	CONDITION (TRANSITION HAPPENS WHEN...)
3	NOT(4) OR Factory-ship mode requested (SFT_CTRL[1:0] = 0b11) OR Software cold reset (SFT_CTRL[1:0] = 0b01) OR Software power-off (SFT_CTRL[1:0] = 0b10) OR Watchdog timer expired (WDT_EXP = 1) OR Manual reset occurred (MAN_RST = 1) OR Device over-temperature lockout ( $T_J > T_{OTLO}$ ) OR SYS undervoltage lockout ( $V_{SYS} < V_{SYSUVLO}$ ) OR SYS overvoltage lockout ( $V_{SYS} > V_{SYSOVLO}$ )
4	Main bias requested enabled through I <sup>2</sup> C (BIAS_REQ = 1) OR 6
5	NOT(6) OR Factory-ship mode requested (SFT_CTRL[1:0] = 0b11) OR Software cold reset (SFT_CTRL[1:0] = 0b01) OR Software power-off (SFT_CTRL[1:0] = 0b10) OR Watchdog timer expired (WDT_EXP = 1) OR Manual reset occurred (MAN_RST = 1) OR Device over-temperature lockout ( $T_J > T_{OTLO}$ ) OR SYS undervoltage lockout ( $V_{SYS} < V_{SYSUVLO}$ ) OR SYS overvoltage lockout ( $V_{SYS} > V_{SYSOVLO}$ )
6	At least one current sink is enabled (EN_SNK1 or EN_SNK2 = 1) OR AMUX is being used (MUX_SEL[3:0] ≠ 0b0000) OR CHGIN inserted and debounced valid (CHGIN_DTLS[1:0] = 0b11) OR LDO is forced enabled (LDO_EN[1:0] = 0b01) OR LDO wake-up flag is set (LDO_WAKE = 1) OR Internal wake-up flag is set (SFT_WAKE = 1)
7	LDO power-up sequence has not happened yet
7A	LDO is forced enabled (LDO_EN[1:0] = 0b01) OR LDO wake-up flag is set (LDO_WAKE = 1) OR Internal wake-up flag is set (SFT_WAKE = 1)
7B	Done with LDO power-up
8	LDO power-down sequence has not happened yet
8A	LDO is forced disabled (LDO_EN[1:0] = 0b00) OR Software cold reset (SFT_CTRL[1:0] = 0b01) OR Software power-off (SFT_CTRL[1:0] = 0b10) OR Watchdog timer expired (WDT_EXP = 1) OR Factory-ship mode requested (SFT_CTRL[1:0] = 0b11) OR Manual reset occurred (MAN_RST = 1) OR Chip over-temperature lockout ( $T_J > T_{OTLO}$ ) OR SYS undervoltage lockout ( $V_{SYS} < V_{SYSUVLO} + V_{SYSUVLO\_HYS}$ ) OR SYS overvoltage lockout ( $V_{SYS} > V_{SYSOVLO}$ )
8B	Done with LDO power-down

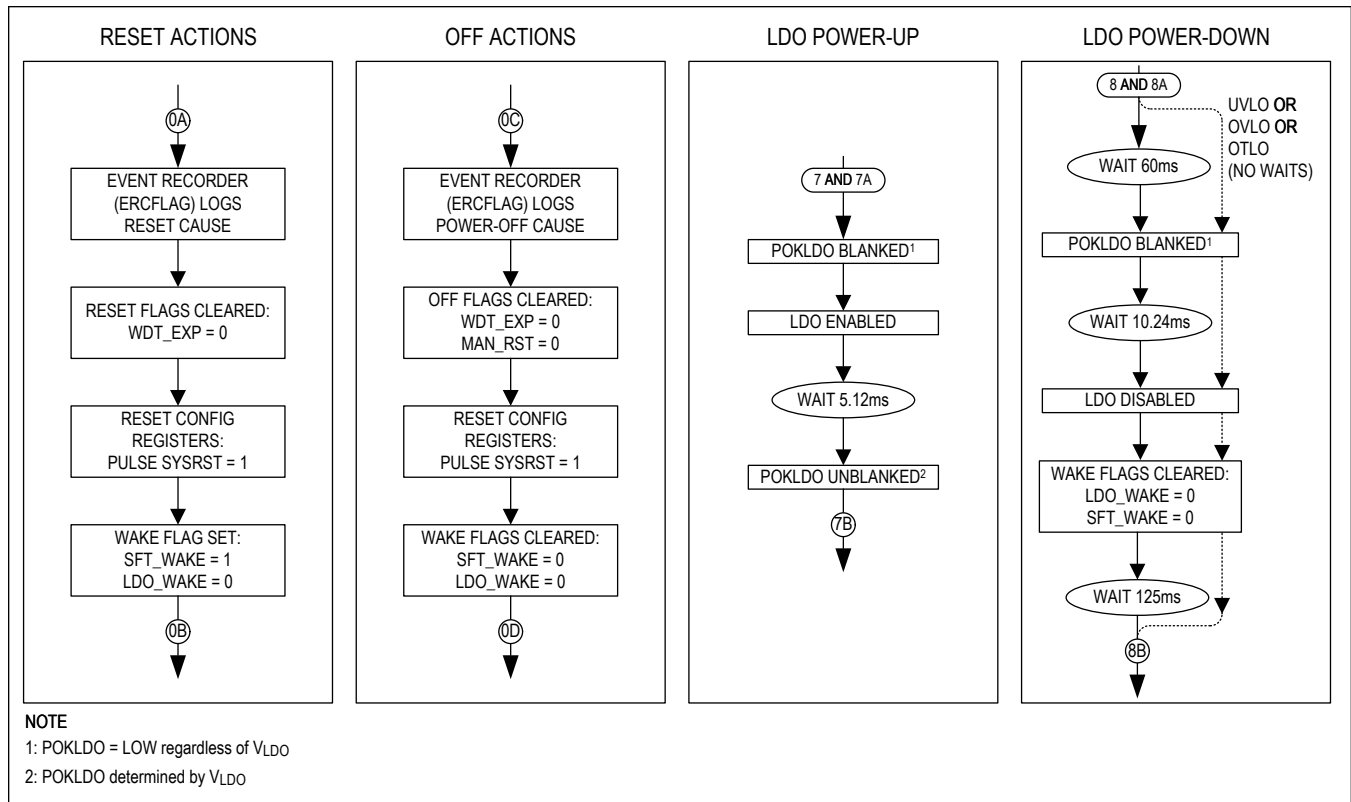

Figure 2. On/Off Controller Action Sequences

The on/off controller operates on internally latched signals which are decoded in [Table 2](#).

**Table 2. On/Off Controller Internal Signals**

SIGNAL NAME	TYPE	DESCRIPTION	SET CONDITION	CLEAR CONDITION
WDT_EXP	Off/Reset Flag	Watchdog timer expired flag. See <a href="#">Watchdog Timer</a> .	Watchdog timer expires	During Reset Actions, Off Actions
MAN_RST	Off/Reset Flag	Manual reset occurred. See <a href="#">Manual Reset</a> .	nENLDO asserted for t <sub>MRST</sub>	During Off Actions
LDO_WAKE	Wake Flag	LDO wakeup flag. See <a href="#">LDO Enable Control</a> .	nENLDO debounced low or CHGIN debounced valid. LDO_EN[1:0] must be 0b10 for this flag to set.	During LDO Power-Down, Off Actions, Reset Actions
SFT_WAKE	Wake Flag	LDO software wakeup flag. See <a href="#">LDO Enable Control</a> .	Software reset (Reset Actions) and LDO_EN[1:0] reset value is 0b10.	During Power-Down, Off Actions
EN_SNKx	Wake Flag	Final enable signal for current sink 1 and 2.	EN_SNK_MSTR = 1 and either SNK_FS1[1:0] != 0b00 or SNK_FS2[1:0] != 0b00	EN_SNK_MSTR = 0 or both SNK_FS1[1:0] = 0b00 and SNK_FS2[1:0] = 0b00

The state machine places a higher priority on events that cause shutdown versus events that cause power-on. In other words, moving the IC to a *lower-power* state is prioritized over moving the IC to a *higher-power* state. When two transitions are true at the same time, the state machine prioritizes action according to [Table 3](#).

**Table 3. On/Off Controller State Transition Priority**

STATE	TRANSITION PRIORITY TO EXIT
FACTORY-SHIP MODE	N/A (single exit path)
SHUTDOWN	2 > 0C > 0A > 4
STANDBY	SYSPOR > 3 > 6
RESOURCE ON	SYSPOR > (8 AND 8A) > 5 > (7 AND 7A)

**Factory-Ship Mode State**

Factory-ship mode internally disconnects the battery (BATT) from the system (SYS). The battery does not power the system in this mode. Use this mode to preserve battery life if external circuits on SYS cause the battery to leak.

Write SFT\_CTRL[1:0] = 0b11 using I<sup>2</sup>C to enter factory-ship mode. The IC responds in two different ways depending on the state of the charger input (CHGIN):

- If CHGIN is valid (CHGIN\_DTLS[1:0] = 0b11) while SFT\_CTRL[1:0] = 0b11, then the IC enters factory-ship mode (internally disconnects BATT from SYS) but SYS is still powered from CHGIN (regulating to V<sub>SYS-REG</sub>). SYS decays to 0V when CHGIN is disconnected.
- If CHGIN is invalid (CHG\_DTLS[1:0] ≠ 0b11) while SFT\_CTRL[1:0] = 0b11, then the IC enters factory-ship mode and SYS decays to 0V.

Factory-ship mode causes many configuration registers to reset (SYSRST). Consult the *Register Map* section of the data sheet for details. I<sup>2</sup>C reads and writes can not happen in factory-ship mode.

Factory-ship mode only exits after SYS decays below approximately 1.8V. Once this condition is met, there are two ways to exit factory-ship mode:

- Apply a valid DC source at CHGIN for t<sub>CHGIN-DB</sub> (120ms typical). Factory-ship mode is unlatched (exited) when the charger input becomes valid from a previously invalid state (CHGIN\_DTLS[1:0] = 0b00 → 0b11).
- Assert nENLDO for t<sub>FSM-EXDB</sub> (250ms typical) + t<sub>DBNC-nENLDO</sub> (0.2ms or 30ms typical).

Furthermore, this state is unlatched if power is removed from the IC (BATT voltage falls below approximately 1.8V). In all exit cases, the Smart Power Selector controls the interaction between BATT and SYS until factory-ship mode is entered again (see [Smart Power Selector](#)).

**Shutdown (Bias Off) State**

The on/off controller is in shutdown (bias off) state when no resources are enabled and CHGIN is invalid. I<sup>2</sup>C is still active as long as V<sub>IO</sub> is valid.

The device shuts down when V<sub>SYS</sub> becomes invalid (< V<sub>SYSUVLO</sub> or > V<sub>SYSOVLO</sub>) or the junction temperature exceeds approximately 165°C (T<sub>OTLO</sub>). Manual reset (MAN\_RST), watchdog timer expiration (WDT\_EXP), or software power-off request (SFT\_CTRL[1:0] = 0b10) also causes shutdown.

The IC exits shutdown when transition 4 in [Table 1](#) is true.

**Standby (Bias On) State**

Standby state is a transitional state used to activate the IC's central bias supply before a resource is allowed to operate. Bias activation is automatically managed by the on/off controller.

**Resource On State**

The IC is in resource on state when at least one resource is enabled:

- CHGIN is valid (CHGIN\_DTLS[1:0] = 0b11) indicating the charger resource is ready to be enabled through CHG\_EN
- The analog multiplexer output buffer is being used (MUX\_SEL[3:0] ≠ 0b0000)
- The LDO is enabled
- At least one of the current sinks is activated (EN\_SNK\_MSTR = 1 and SNK\_FS1/2 ≠ 0b00)

The wake flags in [Table 2](#) also cause the on/off controller to enter this state.

**Hardware Enable (nENLDO)**

nENLDO is an active-low, internally debounced digital input with internal pullup resistors. nENLDO's input signal typically comes from a physical on-key. Asserting nENLDO sets LDO\_WAKE (see [Table 2](#)). This input is also used to exit factory-ship mode (see [Factory-Ship Mode State](#)).

The debounce time is programmable with DB\_nENLDO to either 200µs or 30ms. Both rising and falling edges are debounced. Maskable rising and falling interrupts (nENLDO\_R and nENLDO\_F) are available to signal a change in nENLDO's status. The debounced status of this input is continuously mirrored by the STAT\_ENLDO bit. Consult the *Register Map* for more details.

**Manual Reset**

Asserting nENLDO for an extended period of time causes the IC to shutdown (MAN\_RST = 1).

If nENLDO is continuously asserted for t<sub>MRST</sub> (8 or 16 seconds depending on T\_MRST bit), then the on/off controller shuts down the IC and resets configuration registers (SYSRST). The default value of T\_MRST can be factory-programmed. See the *Register Map* for additional details.

The manual reset function is useful for forcing a register reset and power-down in case communication with the host controller fails. End-applications frequently call this a "hard reset".

The manual reset timer counts differently based on the type of on-key (push-button or slide-switch). See [Push-Button vs. Slide-Switch Functionality](#).

**Push-Button vs. Slide-Switch Functionality**

The nENLDO manual reset ("hard-reset") can be configured to work with a push-button switch or a slide-switch using the nENLDO\_MODE bit.

Use nENLDO\_MODE = 0 for normally-open, momentary, and push-buttons. In this mode, the manual reset timer counts t<sub>MRST</sub> while nENLDO is low (a long button press and hold).

Use nENLDO\_MODE = 1 for persistent slide-switches. In this mode, the manual reset timer counts t<sub>MRST</sub> while nENLDO is high (switch in off position). If the host controller fails to issue a software shutdown command in t<sub>MRST</sub> after nENLDO goes high, then the on/off controller automatically causes a register reset and shutdown.

The default value of nENLDO\_MODE is factory-programmable. [Figure 3](#) shows a visual example of how nENLDO\_MODE changes how t<sub>MRST</sub> is counted.

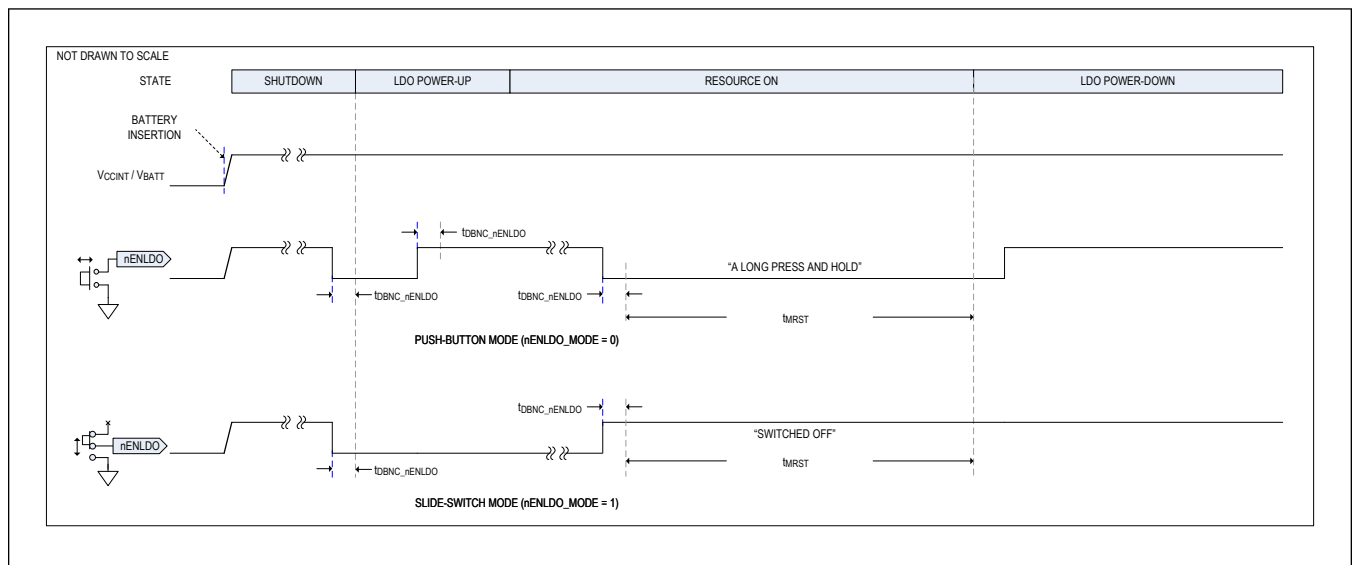

Figure 3. nENLDO Dual-Functionality Timing Diagram

**nENLDO Pullup Resistors to V<sub>CCINT</sub> (V<sub>CC</sub> Internal)**

V<sub>CCINT</sub> is an always-on internal voltage domain. The nENLDO logic thresholds are referenced to V<sub>CCINT</sub>. There are internal pullup resistors between nENLDO and V<sub>CCINT</sub> (R<sub>nEN-PU</sub>). See [Figure 4](#). The pullup strength can be modified with the PU\_DIS bit. While PU\_DIS = 0, the pullup value is approximately 200kΩ (typ). While PU\_DIS = 1, the pullup value is 10MΩ (typ).

V<sub>CCINT</sub> is defined by the following conditions:

- If CHGIN is valid (CHGIN\_DTLS[1:0] = 0b11) and not USB suspended (USBS = 0), then V<sub>CCINT</sub> equals V<sub>L</sub> (3V typ).
- If CHGIN is invalid (CHGIN\_DTLS[1:0] ≠ 0b11) or CHGIN is valid but USB suspended (USBS = 1) then V<sub>CCINT</sub> equals V<sub>BATT</sub>.

Applications using a slide-switch on-key connected to nENLDO can optimize quiescent current consumption by changing pullup strength to 10MΩ by setting PU\_DIS to 1. This is because a slide-switch in the "on position" connects nENLDO to ground and creates a path for BATT to leak (since V<sub>CCINT</sub> = V<sub>BATT</sub> while CHGIN is not present). Applications using normally-open, momentary, and push-button on-keys (as shown in [Figure 4](#)) do not create this leakage path and should use the stronger 200kΩ pullup option (PU\_DIS = 0).

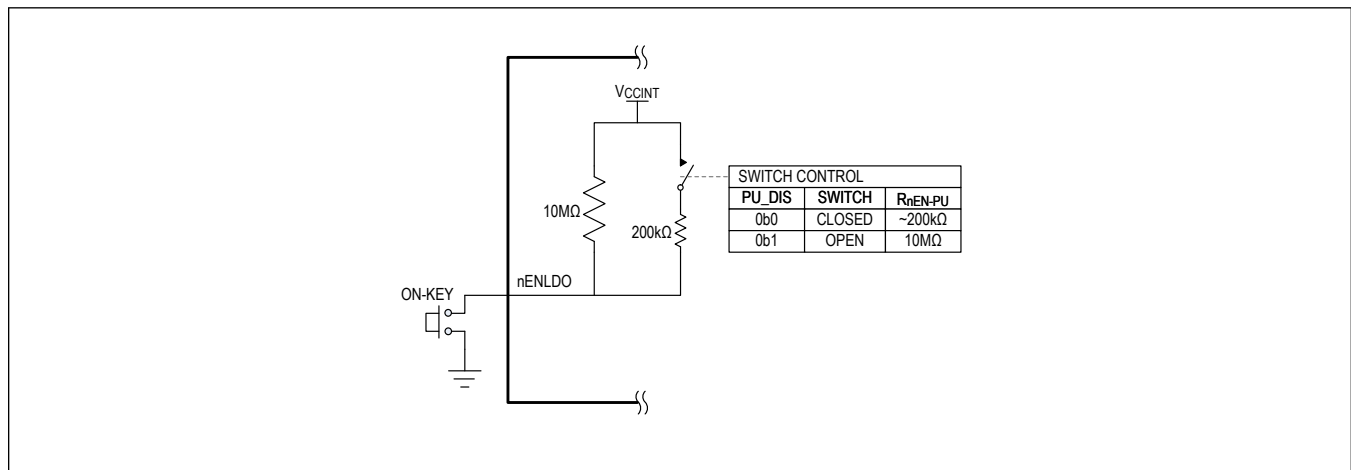

Figure 4. nENLDO Pullup Resistor Configuration

**Power Mode**

The MAX77734 can be placed in a lower-power state to further reduce quiescent current by setting CNFG\_GLBL.BIAS\_LPM = 1. While in low-power mode, the internal bias is sampled-and-held (S/H), and several internal reference voltages are sampled-and-held.

Blocks whose references are sampled:

- LDO reference
- UVLO/OVLO comparator references
- Current sink driver references

Note that the LDO has its own low-power mode. For more details, see the [LDO Power Mode \(PMLDO\)](#) section.

**Interrupts (nIRQ)**

nIRQ is an active-low, open-drain output that is typically routed to the host processor's interrupt input to signal an important change in the ICs status. See the [Register Map](#) for a full list of available status and interrupt bits.

A pullup resistor to a voltage less than or equal to V<sub>SYS</sub> is required for this node. nIRQ is the logical NOR of all unmasked interrupt bits in the ICs register map.

All interrupts are masked by default. Masked interrupt bits do not cause the nIRQ pin to change. Unmask the interrupt bits to allow nIRQ to assert.

### Watchdog Timer

The IC features a watchdog timer function for operational safety. If this timer expires without being cleared, then an internal signal called WDT\_EXP asserts and the on/off controller causes the IC to enter the shutdown state and resets configuration registers. See the [On/Off Controller](#) and List of Transitions (transitions 0A and 0C) for more details.

Write WDT\_EN = 1 through I<sup>2</sup>C to enable the timer. The watchdog timer period (t<sub>WD</sub>) is configurable from 16 to 128 seconds in 4 steps with WDT\_PER[1:0]. The default timer period is 128 seconds. The WDT\_CLR bit must be set through I<sup>2</sup>C periodically (within t<sub>WD</sub>) to reset the timer and prevent shutdown. Consult the *Register Map* and *Watchdog Timer State Machine* (Figure 5) for additional details.

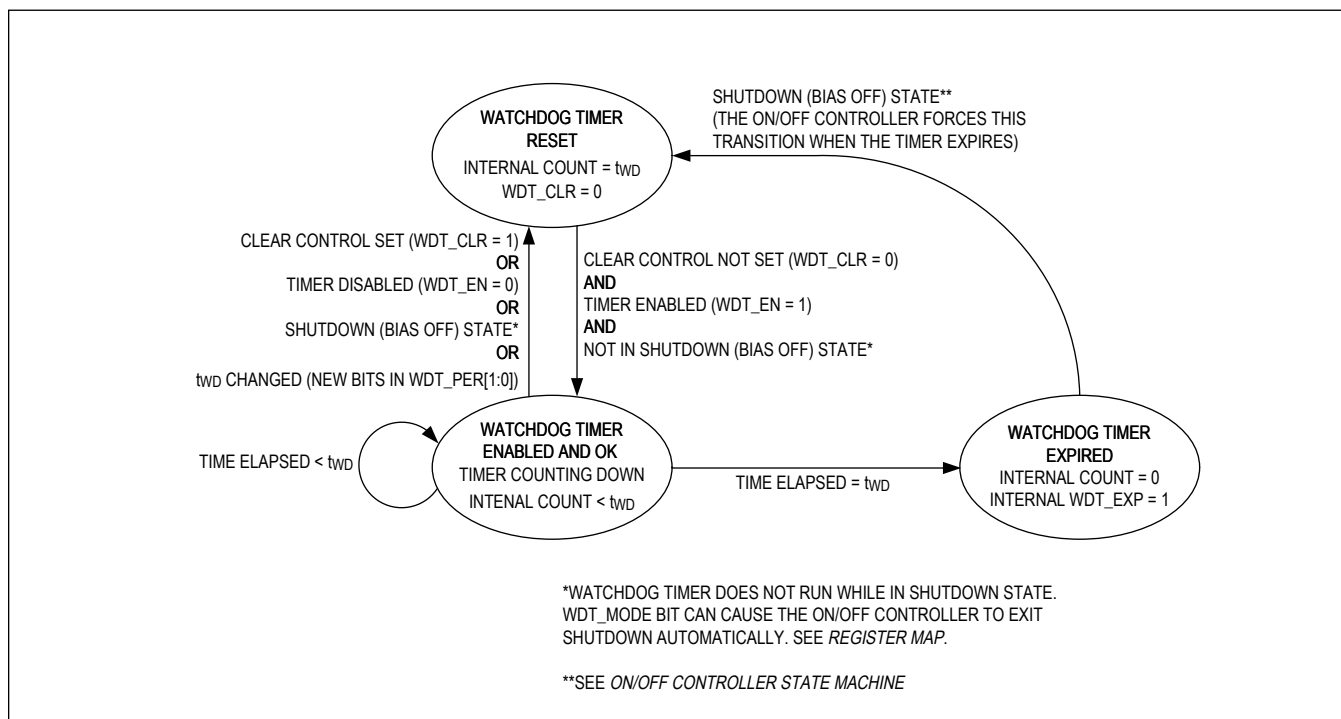

Figure 5. Watchdog Timer State Machine

The timer can be factory-programmed to be enabled by default, disabled by default, or locked from accidental disable. The WDT\_LOCK bit is read-only and must be configured at the factory. See [Table 4](#) for a full description.

**Table 4. Watchdog Timer Factory-Programmed Safety Options**

WDT_LOCK	WDT_EN	FUNCTION
0	0	Watchdog timer is disabled by default. Timer can be enabled or disabled by I <sup>2</sup> C writes.
0	1	Watchdog timer is enabled by default. Timer can be enabled or disabled by I <sup>2</sup> C writes.
1	0	Watchdog timer is disabled by default. Timer can be enabled by an I <sup>2</sup> C write, but only a SYSRST can reset the WDT_EN value back to 0. Timer can not be disabled by direct I <sup>2</sup> C writes to WDT_EN (write from 1 → 0 is ignored, write from 0 → 1 is accepted).
1	1	Watchdog timer is enabled by default. Nothing can disable the timer.

### Thermal Alarms and Protection

The IC has thermal alarms to monitor if the junction temperature rises above 80°C ( $T_{JAL1}$ ) and 100°C ( $T_{JAL2}$ ). Over-temperature lockout (OTLO) is entered if the junction temperature exceeds  $T_{OTLO}$  (approximately 165°C, typ). OTLO causes all resources to turn off immediately. Resources may not enable until the temperature falls below  $T_{OTLO}$  by approximately 15°C.

The  $TJAL1\_S$  and  $TJAL2\_S$  status bits continuously indicate the junction temperature alarm status. Maskable interrupts are available to signal a change in either of these bits. Consult the *Register Map* for details.

### Register Reset Conditions

The IC's registers reset to default values when the corresponding reset condition for each particular bit becomes true. [Table 5](#) lists all register reset conditions. See the *Register Map* for a list of every configuration and status bit and the associated reset value and reset condition.

**Table 5. Register Reset Conditions**

RESET CONDITION	NAME	RESET CAUSE AND DETAILS
SYSPOR	System Power-On Reset	$V_{SYS} < 1.9V$ (typ)
SYSRST	System Reset	SYSPOR OR On/off controller (see transitions 0A and 0C in <a href="#">Table 1</a> )
CHGPOK	Charger Power-OK	CHGPOR OR USB suspend (USBS = 1) OR $V_{CHGIN} < V_{CHGIN\_UVLO}$ (typ. 4V rising, 3.5V falling)
CHGPOR	Charger Power-On Reset	$V_{CHGIN} < 1.9V$ (typ)

### Factory Options

[Table 6](#) shows the factory-programmable (OTP) options for the IC. Refer to the [Ordering Information](#) and *Register Map* for more information about the different default register functions.

**Table 6. Factory-Programmed Defaults (OTP Options)**

	MAX77734BENP	MAX77734CENP	MAX77734GENP	MAX77734QENP	MAX77734MENP
Option Letter	B	C	G	Q	M
Chip Identification	CID[3:0] = 0x1	CID[3:0] = 0x3	CID[3:0] = 0x4	CID[3:0] = 0x7	CID[3:0] = 0x8
I <sup>2</sup> C Device Address (7-bit)	0x48	0x48	0x48	0x48	0x48
$V_{SYSUVLO}$ (falling UVLO threshold)	2.85V	2.85V	2.85V	2.85V	2.50V
$V_{SYSUVLO\_HYS}$ (UVLO hysteresis)	0.15V	0.15V	0.15V	0.15V	0.15V
CHG_EN (default charger enable bit)	0 (disabled)	0 (disabled)	1 (enabled)	1 (enabled)	0 (disabled)
I <sub>CHGIN-LIM</sub> (default input current limit)	475mA	95mA	95mA	475mA	475mA
LDO_VREG[6:0] (default LDO voltage)	0x28 (1.8V)	0x64 (3.3V)	0x64 (3.3V)	0x64 (3.3V)	0x28 (1.8V)
LDO_EN[1:0] (default LDO enable)	0b00 (disabled)	0b10 (hardware enable)	0b10 (hardware enable)	0b10 (hardware enable)	0b00 (disabled)
DB_nENLDO (nENLDO input debounce time)	1 (30ms)	1 (30ms)	1 (30ms)	1 (30ms)	1 (30ms)

**Table 6. Factory-Programmed Defaults (OTP Options) (continued)**

nENLDO_MODE (button type)	0 (push-button)	0 (push-button)	0 (push-button)	0 (push-button)	0 (push-button)
T_MRST (manual reset time)	0 (8s)	0 (8s)	0 (8s)	0 (8s)	0 (8s)
WDT_EN (watchdog timer enable)	0 (disabled)	0 (disabled)	0 (disabled)	1 (enabled)	0 (disabled)
WDT_LOCK (watchdog timer enable lock)	0 (unlocked)	0 (unlocked)	0 (unlocked)	0 (unlocked)	0 (unlocked)

### Detailed Description—Smart Power Selector Charger

The linear Li+ charger implements power path with Maxim's Smart Power Selector. This allows separate input current limit and battery charge current settings. Batteries charge faster under the supervision of the Smart Power Selector because charge current is independently regulated and not shared with variable system loads. See the [Smart Power Selector](#) section for more information.

The programmable constant-current charge rate (7.5mA to 300mA) supports a wide range of battery capacities. The programmable input current limit (95mA to 475mA) supports a range of charge sources, including USB. The charger's programmable battery regulation voltage range (3.6V–4.6V) supports a wide variety of cell chemistries. Small battery capacities are supported; the charger accurately terminates charging by detecting battery currents as low as 0.375mA.

Additionally, the robust charger input withstands overvoltages up to 28V. To enhance charger safety, an NTC thermistor provides temperature monitoring in accordance with the JEITA recommendations. See the Detailed Description—Adjustable Thermistor Temperature Monitors section for more information.

### Charger Symbol Reference Guide

[Table 7](#) lists the names and functions of charger-specific signals and if they can be programmed through I<sup>2</sup>C. Consult the [Electrical Characteristics](#) and [Register Map](#) for more information.

**Table 7. Charger Quick Symbol Reference Guide**

SYMBOL	NAME	I <sup>2</sup> C PROGRAMMABLE?
V <sub>CHGIN_OVP</sub>	CHGIN overvoltage threshold	No
V <sub>CHGIN_UVLO</sub>	CHGIN undervoltage-lockout threshold	No
V <sub>CHGIN-MIN</sub>	Minimum CHGIN voltage regulation setpoint	Yes, through V <sub>CHGIN_MIN</sub> [2:0]
I <sub>CHGIN-LIM</sub>	CHGIN input current limit	Yes, through I <sub>CHGIN_LIM</sub> [2:0]
V <sub>SYS-REG</sub>	SYS voltage regulation target	Yes, through V <sub>SYS_REG</sub> [4:0]
V <sub>SYS-MIN</sub>	Minimum SYS voltage regulation setpoint	No, tracks V <sub>SYS-REG</sub>
V <sub>FAST-CHG</sub>	Fast-charge constant-voltage level	Yes, through CHG_CV[5:0]
I <sub>FAST-CHG</sub>	Fast-charge constant-current level	Yes, through CHG_CC[5:0]
I <sub>PQ</sub>	Prequalification current level	Yes, through I_PQ
V <sub>PQ</sub>	Prequalification voltage threshold	Yes, through CHG_PQ[2:0]
I <sub>TERM</sub>	Termination current level	Yes, through I_TERM[1:0]
T <sub>J-REG</sub>	Die temperature regulation setpoint	Yes, through T <sub>J_REG</sub> [2:0]
t <sub>PQ</sub>	Prequalification safety timer	No
t <sub>FC</sub>	Fast-charge safety timer	Yes, through T_FAST_CHG[1:0]
t <sub>TO</sub>	Top-off timer	Yes, through T_TOPOFF[2:0]

[Figure 6](#) indicates the high-level functions of each control circuit within the linear charger.

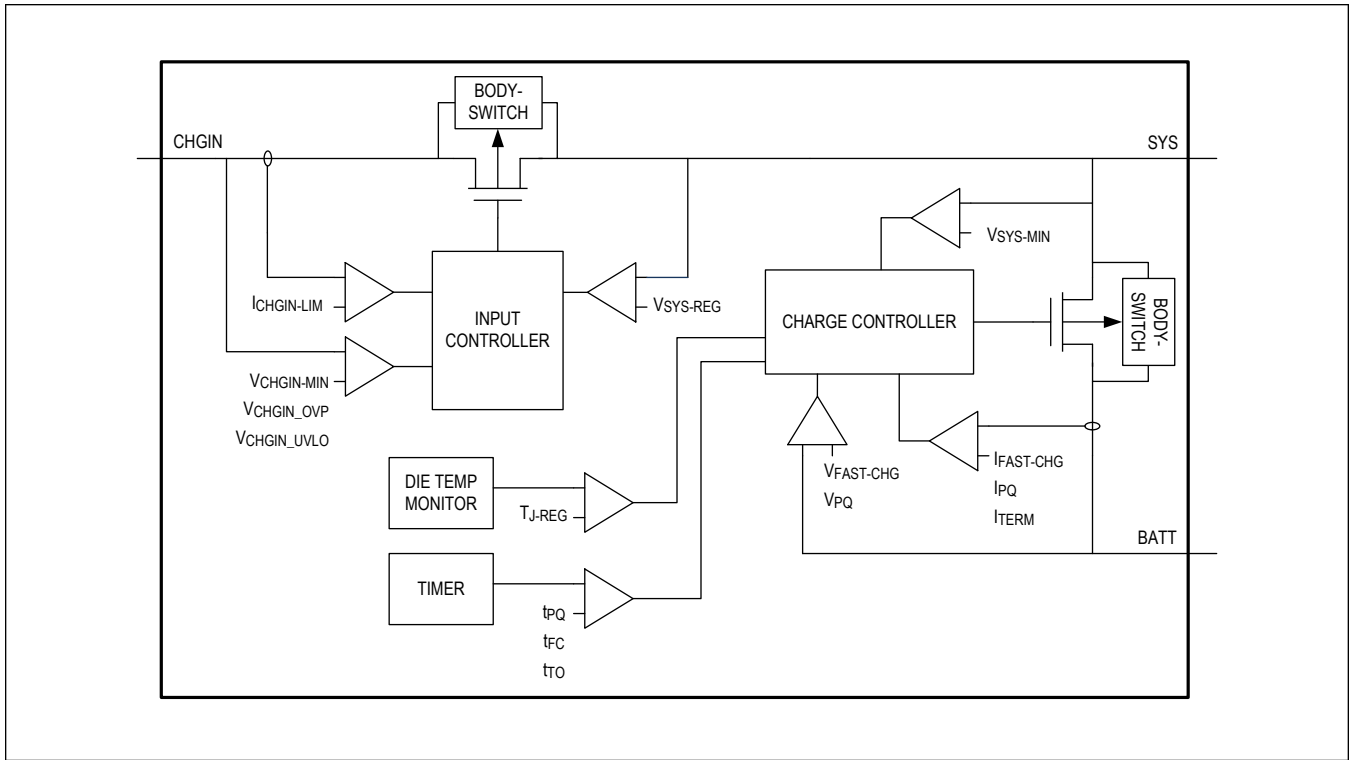

Figure 6. Charger Simplified Control Loops

### Smart Power Selector

The Smart Power Selector seamlessly distributes power from the input (CHGIN) to the battery (BATT) and the system (SYS). The Smart Power Selector basic functions are:

- When the system load current is less than the input current limit, the battery is charged with residual power from the input.
- When a valid input source is connected, the system regulates to  $V_{SYS-REG}$  to power system loads regardless of the battery's voltage (instant on).
- When the system load current exceeds the input current limit, the battery provides additional current to the system (supplement mode).
- When the battery is finished charging and an input source is present to power the system, the battery remains disconnected from the system.
- When the battery is connected and there is no input power, the system is powered from the battery.

### Input Current Limiter

The input current limiter limits CHGIN current to not exceed  $I_{CHGIN-LIM}$  (programmed by ICHGIN\_LIM[2:0]). A maskable interrupt (CHGIN\_CTRL\_I) signals when the input current limit engages. The ICHGIN\_LIM\_STAT bit reflects the state of the current limiter loop.

The default value of  $I_{CHGIN-LIM}$  is factory-programmable to either 95mA or 475mA. The decoding of the ICHGIN\_LIM[2:0] bitfield changes depending on the factory-programmed default value (see Table 8). The reset value of this bitfield is always 0b000 regardless of factory option.

**Table 8. Input Current Limit Factory Options**

ICHGIN_LIM[2:0]	95mA FACTORY-DEFAULT	475mA FACTORY-DEFAULT
0b000	95mA	475mA

**Table 8. Input Current Limit Factory Options (continued)**

ICHGIN_LIM[2:0]	95mA FACTORY-DEFAULT	475mA FACTORY-DEFAULT
0b001	190mA	380mA
0b010	285mA	285mA
0b011	380mA	190mA
0b100 - 0b111	475mA	95mA

CHGIN is capable of standing off 28V from ground. CHGIN suspends power delivery to the system and battery when  $V_{CHGIN}$  exceeds  $V_{CHGIN\_OVP}$  (7.5V, typ). The input circuit also suspends when  $V_{CHGIN}$  falls below  $V_{CHGIN\_UVLO}$  minus 500mV of hysteresis (3.5V, typ). While in OVP or UVLO, the charger remains off and the battery provides power to the system.

Power transfer to SYS is delayed by a 120ms debounce timer ( $t_{CHGIN\_DB}$ ) after a valid DC source is connected to CHGIN. SYS does not begin regulating to  $V_{SYS\_REG}$  until after the timer expires.

The CHGIN\_DTLS[1:0] bitfield continuously indicates the state of CHGIN's voltage quality. A maskable interrupt (CHGIN\_I) asserts when CHGIN\_DTLS[1:0] changes.

### Minimum Input Voltage Regulation

In the event of a poor-quality charge source, the minimum input voltage regulation loop works to reduce input current if  $V_{CHGIN}$  falls below  $V_{CHGIN\_MIN}$  (programmed by  $V_{CHGIN\_MIN}[2:0]$ ). This is important because many commonly used charge adapters feature foldback protection mechanisms where the adapter completely shuts off if its output drops too low. The minimum input voltage regulation loop also prevents  $V_{CHGIN}$  from dropping below  $V_{CHGIN\_UVLO}$  if the cable between the charge source and the charger's input is long or highly resistive.

The input voltage regulation loop improves performance with current limited adapters. If the charger's input current limit is programmed above the current limit of the given adapter, the input voltage loop allows the input to regulate at the current limit of the adapter. The input voltage regulation loop also allows the charger to perform well with adapters that have poor transient load response times.

A maskable interrupt (CHGIN\_CTRL\_I) signals when the minimum input voltage regulation loop engages. The state of this loop is reflected by  $V_{CHGIN\_MIN\_STAT}$ .

### Minimum System Voltage Regulation

The minimum system voltage regulation loop ensures that the system rail remains close to the programmed SYS regulation voltage ( $V_{SYS\_REG}$ ) regardless of system loading. The loop engages when the combined battery charge current and system load current causes the CHGIN input to current limit at  $I_{CHGIN\_LIM}$ . When this happens, the minimum system voltage loop reduces charge current in an attempt to keep the input out of current limit, thereby keeping the system voltage above  $V_{SYS\_MIN}$  ( $V_{SYS\_REG} - 100mV$ , typ). If this loop reduces battery current to 0 and the system is in need of more current than the input can provide, then the Smart Power Selector overrides the minimum system voltage regulation loop and allows SYS to collapse to BATT for the battery to provide supplement current to the system. The Smart Power Selector automatically reenables the minimum system voltage loop when the supplement event has ended.

A maskable interrupt (SYS\_CTRL\_I) asserts to signal a change in  $V_{SYS\_MIN\_STAT}$ . This status bit asserts when the minimum system voltage regulation loop is active.

### Die Temperature Regulation

If the die temperature exceeds  $T_{J\_REG}$  (programmed by  $T_{J\_REG}[2:0]$ ) the charger attempts to limit the temperature increase by reducing battery charge current. The  $T_{J\_REG\_STAT}$  bit asserts whenever charge current is reduced due to this loop. The charger's current sourcing capability to SYS remains unaffected when  $T_{J\_REG\_STAT}$  is high. A maskable interrupt ( $T_{J\_REG\_I}$ ) asserts to signal a change in  $T_{J\_REG\_STAT}$ . Use the  $T_{J\_REG\_I}$  interrupt to signal the system processor to reduce loads on SYS to reduce total system temperature.

**Charger State Machine**

The battery charger follows a strict state-to-state progression to ensure that a battery is charged safely. The status bitfield CHG\_DTLS[3:0], reflects the charger's current operational state. A maskable interrupt (CHG\_I) is available to signal a change in CHG\_DTLS[3:0].

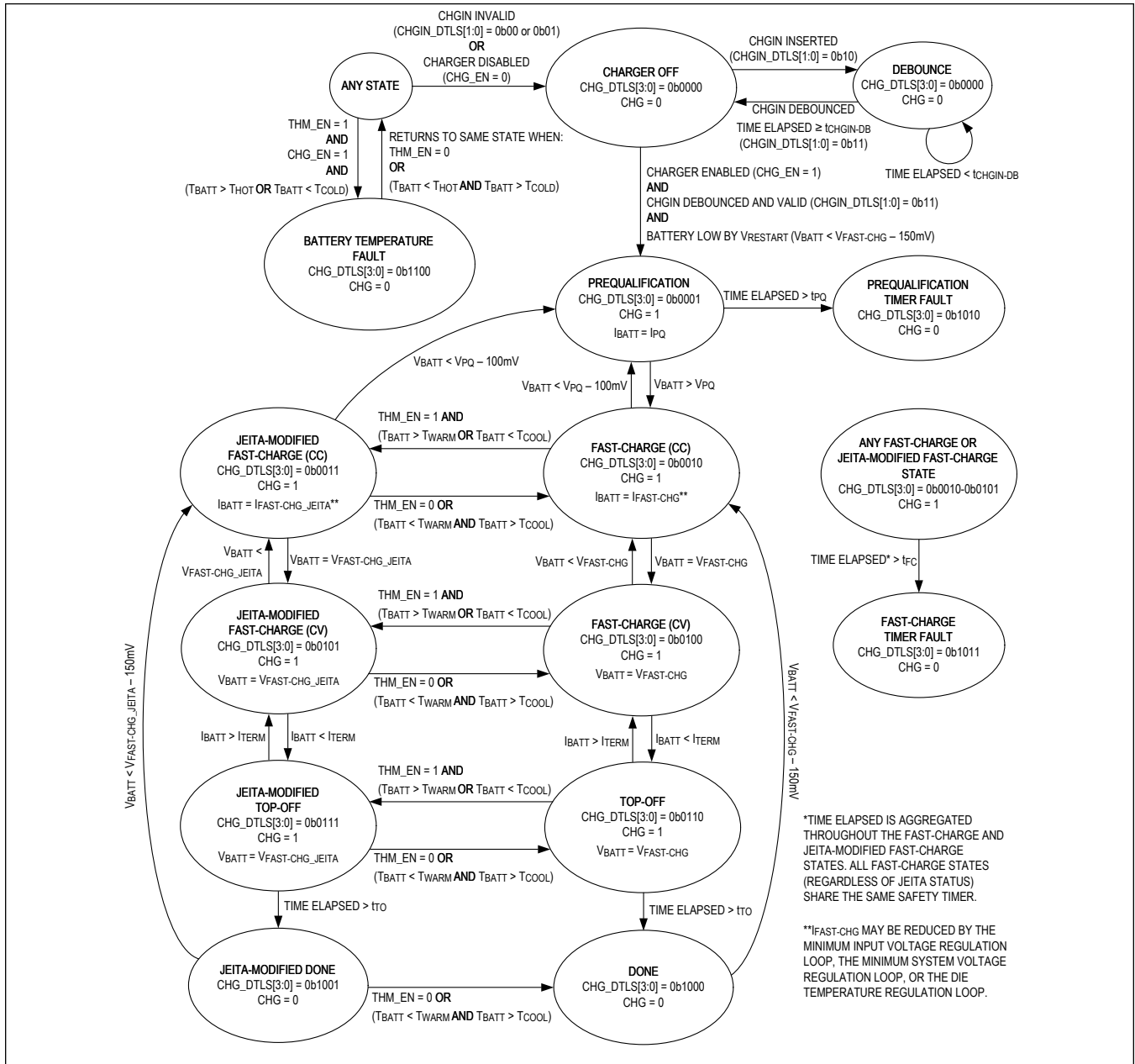

Figure 7. Charger State Diagram

**Charger Off State**

The charger is off when CHGIN is invalid, the charger is disabled, or the battery is fresh. CHGIN is invalid when the CHGIN input is invalid ( $V_{CHGIN} < V_{CHGIN\_UVLO}$  or  $V_{CHGIN} > V_{CHGIN\_OVP}$ ). While

CHGIN is invalid, the battery is connected to the system. CHGIN voltage quality can be separately monitored by the CHGIN\_DTLS[1:0] status bitfield. Refer to the *Register Map* for details.

The charger is disabled when the charger enable bit is 0 (CHG\_EN = 0). The battery is connected or disconnected to the system depending on the validity of V<sub>CHGIN</sub> while CHG\_EN = 0. See the [Smart Power Selector](#) section.

The battery is fresh when CHGIN is valid and the charger is enabled (CHG\_EN = 1) and the battery is not low by V<sub>RESTART</sub> (V<sub>BATT</sub> > V<sub>FAST-CHG</sub> - V<sub>RESTART</sub>). The battery is disconnected from the system and not charged while the battery is fresh. The charger state machine exits this state and begins charging when the battery becomes low by V<sub>RESTART</sub> (150mV, typ). This condition is functionally similar to done state. See [Done State](#) section.

### Prequalification State

The prequalification state is intended to assess a low-voltage battery's health by charging at a reduced rate. If the battery voltage is less than the V<sub>PQ</sub> threshold, the charger is automatically in prequalification. If the cell voltage does not exceed V<sub>PQ</sub> in 30 minutes (t<sub>PQ</sub>), the charger faults. The prequalification charge rate is a percentage of I<sub>FAST-CHG</sub> and is programmable with I<sub>PQ</sub>. The prequalification voltage threshold (V<sub>PQ</sub>) is programmable through CHG\_PQ[2:0].

### Fast-Charge States

When the battery voltage is above V<sub>PQ</sub>, the charger transitions to the fast-charge (CC) state. In this state, the charger delivers a constant current (I<sub>FAST-CHG</sub>) to the cell. The constant current level is programmable from 7.5mA to 300mA by CHG\_CC[5:0].

When the cell voltage reaches V<sub>FAST-CHG</sub>, the charger state machine transitions to fast-charge (CV). V<sub>FAST-CHG</sub> is programmable with CHG\_CV[5:0] from 3.6V to 4.6V. The charger holds the battery's voltage constant at V<sub>FAST-CHG</sub> while in the fast-charge (CV) state. As the battery approaches full, the current accepted by the battery reduces. When the charger detects that battery charge current has fallen below I<sub>TERM</sub>, the charger state machine enters the top-off state.

A fast-charge safety timer starts when the state machine enters fast-charge (CC) or JEITA-modified fast-charge (CC) from a non-fast-charge state. The timer continues to run through all fast-charge states regardless of JEITA status. The timer length (t<sub>FC</sub>) is programmable from 3 hours to 7 hours in 2 hour increments with T\_FAST\_CHG[1:0]. If it is desired to charge without a safety timer, program T\_FAST\_CHG[1:0] with 0b00 to disable the feature. If the timer expires before the fast-charge states are exited, the charger faults. See the [Fast-Charge Timer Fault State](#) section for more information.

If the charge current falls below 20% of the programmed value during fast-charge (CC), the safety timer pauses. The timer also pauses for the duration of supplement mode events. The TIME\_SUS bit indicates the status of the fast-charge safety timer. Refer to the *Register Map* for more details.

### Top-Off State

Top-off state is entered when the battery charge current falls below I<sub>TERM</sub> during the fast-charge (CV) state. I<sub>TERM</sub> is a percentage of I<sub>FAST-CHG</sub> and is programmable through I\_TERM[1:0]. While in the top-off state, the battery charger continues to hold the battery's voltage at V<sub>FAST-CHG</sub>. A programmable top-off timer starts when the charger state machine enters the top-off state. When the timer expires, the charger enters the done state. The top-off timer value (t<sub>TO</sub>) is programmable from 0 minutes to 35 minutes with T\_TOPOFF[2:0]. If it is desired to stop charging as soon as battery current falls below I<sub>TERM</sub>, program t<sub>TO</sub> to 0 minutes.

### Done State

The charger enters the done state when the top-off timer expires. The battery remains disconnected from the system during done. The charger restarts if the battery voltage falls more than V<sub>RESTART</sub> (150mV, typ) below the programmed V<sub>FAST-CHG</sub> value.

### Prequalification Timer Fault State

The prequalification timer fault state is entered when the battery's voltage fails to rise above V<sub>PQ</sub> in t<sub>TO</sub> (30 minutes, typ) from when the prequalification state was first entered. If a battery is too deeply discharged, damaged, or internally shorted, the prequalification timer fault state can occur. During the timer fault state, the charger stops delivering current to the battery and the battery remains disconnected from the system. To exit the prequalification timer fault state, toggle the charger enable (CHG\_EN) bit or unplug and replug the external voltage source connected to CHGIN.

**Fast-Charge Timer Fault State**

The charger enters the fast-charge timer fault state if the fast-charge safety timer expires. While in this state, the charger stops delivering current to the battery and the battery remains disconnected from the system. To exit the fast-charge timer fault state, toggle the charger enable bit (CHG\_EN) or unplug and replug the external voltage source connected to CHGIN.

**Battery Temperature Fault State**

If the thermistor monitoring circuit reports that the battery is either too hot or too cold to charge (as programmed by THM\_HOT[1:0] and THM\_COLD[1:0]), the state machine enters the battery temperature fault state. While in this state, the charger stops delivering current to the battery and the battery remains disconnected from the system. This state can only be entered if the thermistor is enabled (THM\_EN = 1). Battery temperature fault state has priority over any other fault state, and can be exited when the thermistor is disabled (THM\_EN = 0) or when the battery returns to an acceptable temperature. When this fault state is exited, the state machine returns to the last state it was in before battery temperature fault state was entered.

All active charger timers (fast-charge safety timer, prequalification timer, or top-off timer) are paused in this state. When the charger exits this state, the prequalification timer resumes while the fast-charge safety and top-off timers reset.

The THM\_DTLS[2:0] bitfield reports battery temperature status. See the [Electrical Characteristics—Adjustable Thermistor Temperature Monitors](#) section and refer to the *Register Map* for more information.

**JEITA-Modified States**

If the thermistor is enabled (THM\_EN = 1), then the charger state machine is allowed to enter the JEITA-modified states. These states are entered if the charger's temperature monitors indicate that the battery temperature is either warm (greater than  $T_{WARM}$ ) or cool (lesser than  $T_{COOL}$ ). See the [Electrical Characteristics—Adjustable Thermistor Temperature Monitors](#) section for more information about setting the temperature thresholds.

The charger's current and voltage parameters change from I<sub>FAST-CHG</sub> and V<sub>FAST-CHG</sub> to I<sub>FAST-CHG\_JEITA</sub> and V<sub>FAST-CHG\_JEITA</sub> while in the JEITA-modified states. The JEITA modified parameters can be independently set to lower voltage and current values so that the battery can charge safely over a wide range of ambient temperatures. If the battery temperature returns to normal, or the thermistor is disabled (THM\_EN = 0), the charger exits the JEITA-modified states.

**Typical Charge Profile**

A typical battery charge profile (and state progression) is illustrated in [Figure 8](#).

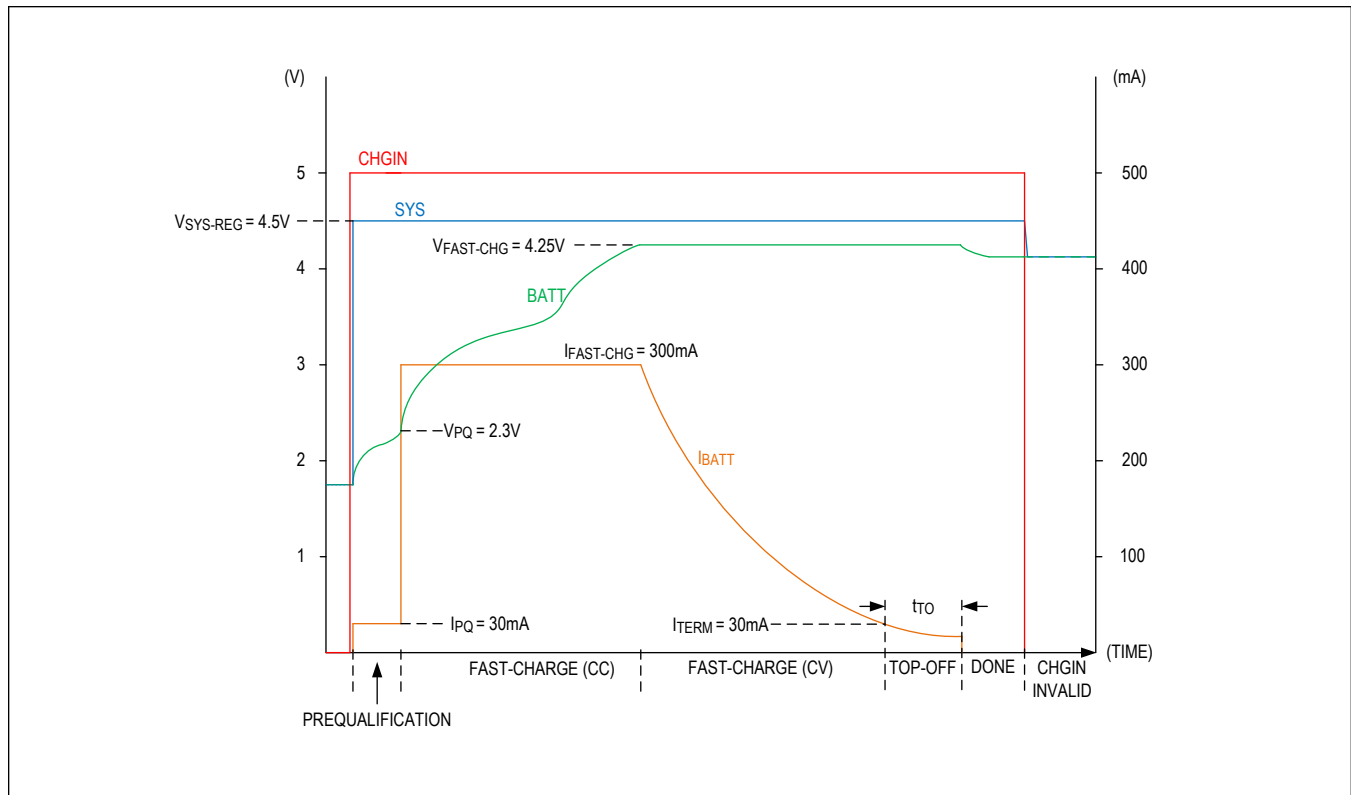

Figure 8. Example Battery Charge Profile

## Charger Applications Information

### Configuring a Valid System Voltage

The Smart Power Selector begins to regulate SYS to  $V_{\text{SYS-REG}}$  when CHGIN is connected to a valid source. To ensure the charger's accuracy specified in the [Electrical Characteristics](#) table, the system voltage must always be programmed at least 200mV above the charger's constant-voltage level ( $V_{\text{FAST-CHG}}$ ). If this condition is not met, then the charger's internal configuration logic forces  $V_{\text{FAST-CHG}}$  to reduce to satisfy the 200mV requirement. If this happens, the charger asserts the SYS\_CNFG\_I interrupt to alert the user that a configuration error has been made and that the bits in CHG\_CV[5:0] have changed to reduce  $V_{\text{FAST-CHG}}$ .

### CHGIN/SYS/BATT Capacitor Selection

Bypass CHGIN to GND with a 4.7 $\mu\text{F}$  ceramic capacitor to minimize inductive kick caused by long cables between the DC charge source and the product/IC. Larger values increase decoupling for the linear charger, but increase inrush current from the DC charge source when the product/IC is first connected to a source through a cable/plug. If the DC charging source is an upstream USB device, limit the maximum CHGIN input capacitance based on the appropriate USB specification (i.e., typically no more than 10 $\mu\text{F}$ ).

Bypass SYS to GND with a 22 $\mu\text{F}$  ceramic capacitor. This capacitor is needed to ensure stability of SYS while it is being regulated from CHGIN. Larger values of SYS capacitance increase decoupling for all SYS loads. The effective value of the SYS capacitor must be greater than 4 $\mu\text{F}$  and no more than 100 $\mu\text{F}$ .

Bypass BATT to GND with a 4.7 $\mu\text{F}$  ceramic capacitor. This capacitor is required to ensure stability of the BATT voltage regulation loop. The effective value of the BATT capacitor must be greater than 1 $\mu\text{F}$ .

Ceramic capacitors with X5R or X7R dielectric are highly recommended due to their small size, low ESR, and small temperature coefficients. All ceramic capacitors derate with DC bias voltage (effective capacitance goes down as DC bias goes up). Generally, small case size capacitors derate heavily compared to larger case sizes (0603 case size

performs better than 0402). Consider the effective capacitance value carefully by consulting the manufacturer's data sheet.

## Detailed Description—Adjustable Thermistor Temperature Monitors

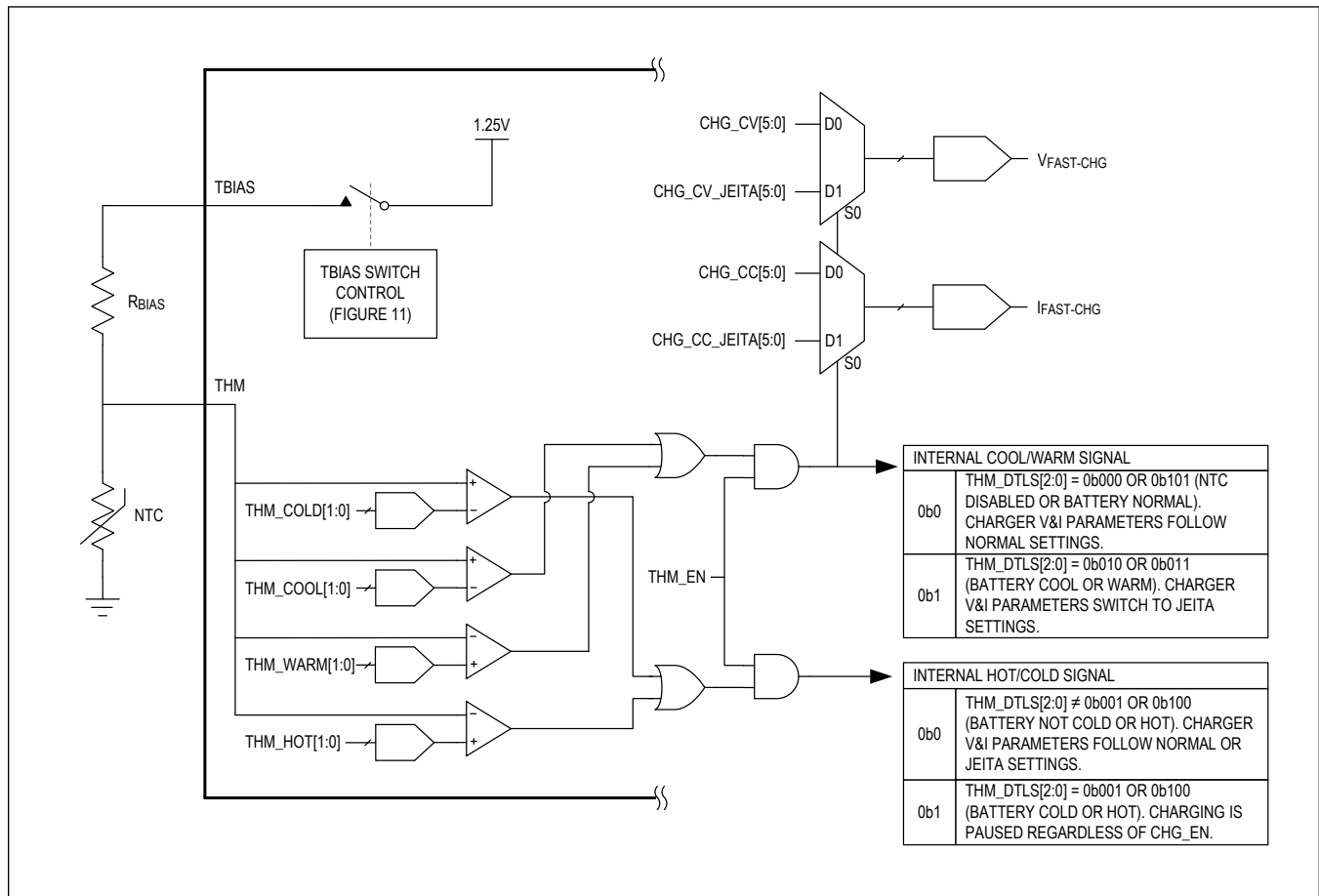

Figure 9. Thermistor Logic Functional Diagram

The optional use of a negative temperature coefficient (NTC) thermistor (thermally coupled to the battery) enables the charger to operate safely over the JEITA temperature range. When the thermistor is enabled (THM\_EN = 1), the charger continuously monitors the voltage at the THM pin in order to sense the temperature of the battery being charged.

See [Figure 10](#) for a visual example of the following text:

- If the battery temperature is higher than  $T_{COOL}$  and lower than  $T_{WARM}$ , the battery charges normally with the normal values for  $V_{FAST-CHG}$  and  $I_{FAST-CHG}$ . The charger state machine does not enter JEITA-modified states while the battery temperature is normal.
- If the battery temperature is either above  $T_{WARM}$  but below  $T_{HOT}$ , or below  $T_{COOL}$  but above  $T_{COLD}$ , the battery charges with the JEITA-modified voltage and current values. These modified values,  $V_{FAST-CHG\_JEITA}$  and  $I_{FAST-CHG\_JEITA}$ , are programmable through CHG\_CV\_JEITA[5:0] and CHG\_CC\_JEITA[5:0], respectively. These values are independently programmable from the nonmodified  $V_{FAST-CHG}$  and  $I_{FAST-CHG}$  values and can even be programmed to the same values if an automatic response to a warm or cool battery is not desired. The charger state machine enters JEITA-modified states while the battery temperature is outside of normal.
- If the battery temperature is either above  $T_{HOT}$  or below  $T_{COLD}$ , the charger follows the JEITA recommendation and pauses charging. The charger state machine enters battery temperature fault state while charging is paused due to

extreme high or low temperatures.

The battery's temperature status is reflected by the THM\_DTLS[2:0] status bitfield. A maskable interrupt (THM\_I) signals a change in THM\_DTLS[2:0]. Refer to the *Register Map* for more information. To completely disable the charger's automatic response to battery temperature, disable the feature by programming THM\_EN = 0.

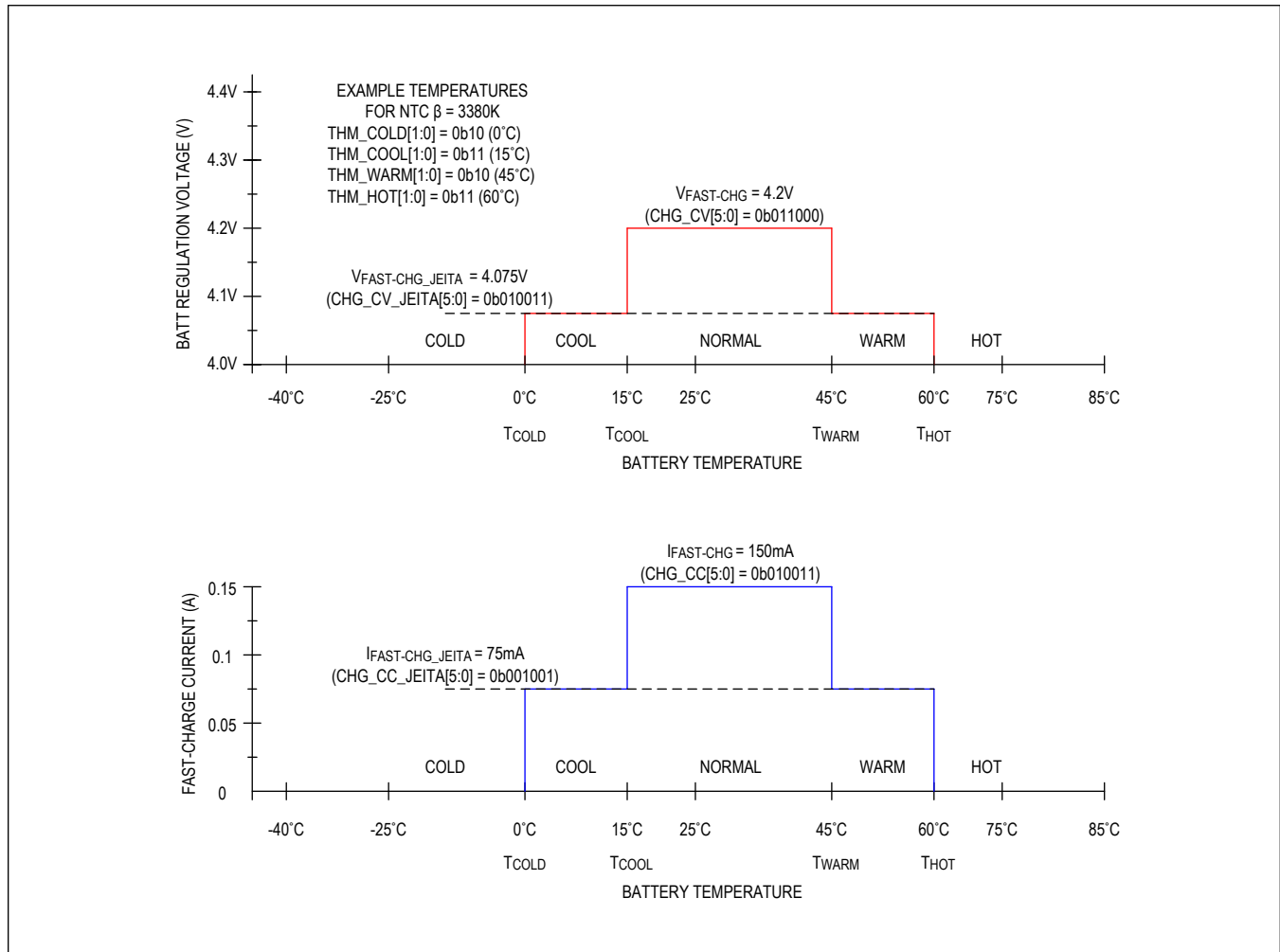

Figure 10. Safe-Charging Profile Example

The voltage thresholds corresponding to the JEITA temperature thresholds are independently programmable through THM\_HOT[1:0], THM\_WARM[1:0], THM\_COOL[1:0], and THM\_COLD[1:0]. Each threshold can be programmed to one of four voltage options spanning 15°C for an NTC beta of 3380K. See the [Configurable Temperature Thresholds](#) section and refer to the *Register Map* for more information.

### Thermistor Bias

An external ADC can optionally perform conversions on the THM and TBIAS pins to measure the battery's temperature. An on-chip analog multiplexer is used to route these nodes to the AMUX pin. The operation of the analog multiplexer does not interfere with the charger's temperature monitoring comparators or the charger's automatic JEITA response. See the [Detailed Description—Analog Multiplexer](#) section for more information.

The NTC thermistor's bias source (TBIAS) follows the simple operation outlined as follows:

- If CHGIN is valid and the thermistor is enabled (THM\_EN = 1), then the thermistor is biased so the charger can automatically respond to battery temperature changes.
- If the analog multiplexer is connecting THM or TBIAS to AMUX, then the thermistor is biased so an external ADC can perform a meaningful temperature conversion.

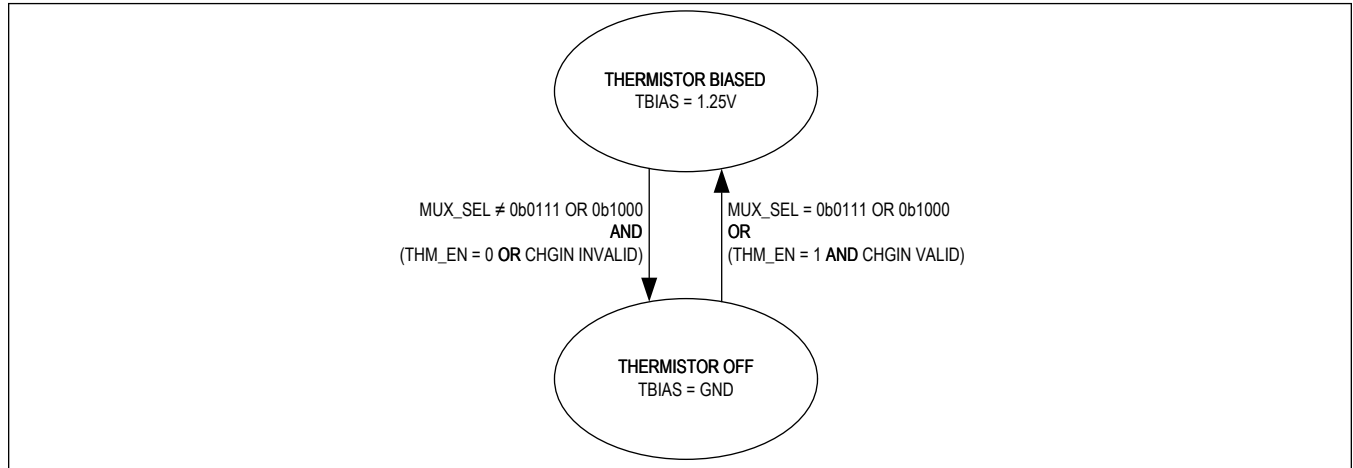

Figure 11. Thermistor Bias State Diagram

The AMUX pin is a buffered output. The operation of the analog multiplexer and external ADC does not collide with the function of the on-chip temperature monitors. Both functions can be used simultaneously with no ill effect.

### Configurable Temperature Thresholds

Temperature thresholds for different NTC thermistor beta values are listed in [Table 9](#). The largest possible programmable temperature range can be realized by using an NTC with a beta of 3380K. Using a larger beta compresses the temperature range. The trip voltage thresholds are programmable with the THM\_HOT[1:0], THM\_WARM[1:0], THM\_COOL[1:0], and THM\_COLD[1:0] bitfields. All possible programmable trip voltages are listed in [Table 9](#).

**Table 9. Trip Temperatures vs. Trip Voltages for Different NTC β**

TRIP VOLTAGE (V)	TRIP TEMPERATURES (°C)					
	3380K	3435K	3940K	4050K	4100K	4250K
1.024	-10.0	-9.5	-5.6	-4.8	-4.5	-3.5
0.976	-5.0	-4.6	-1.1	-0.5	-0.2	0.6
0.923	0.0	0.3	3.3	3.8	4.1	4.8
0.867	5.0	5.3	7.7	8.1	8.3	8.9
0.807	10.0	10.2	12.0	12.4	12.5	12.9
0.747	15.0	15.1	16.4	16.6	16.7	17.0
0.511	35.0	34.8	33.5	33.3	33.2	32.9
0.459	40.0	39.8	37.8	37.4	37.3	36.8
0.411	45.0	44.7	42.0	41.5	41.3	40.7
0.367	50.0	49.6	46.2	45.6	45.3	44.6
0.327	55.0	54.5	50.4	49.7	49.3	48.4
0.291	60.0	59.4	54.6	53.7	53.3	52.2

These are theoretical values computed by a formula. Refer to the particular NTC's data sheet for more accurate measured data. In all cases, select the value of R<sub>BIAS</sub> to be equal to the NTC's effective resistance at +25°C.

**Thermistor Applications Information**

**Using Different Thermistor  $\beta$**

If an NTC with a beta larger than 3380K is used and the resulting available programmable temperature range is undesirably small, then two adjusting resistors can be used to expand the temperature range.  $R_S$  and  $R_P$  can be optionally added to the NTC thermistor circuit (shown in [Figure 12](#)) to expand the range of programmable temperature thresholds.

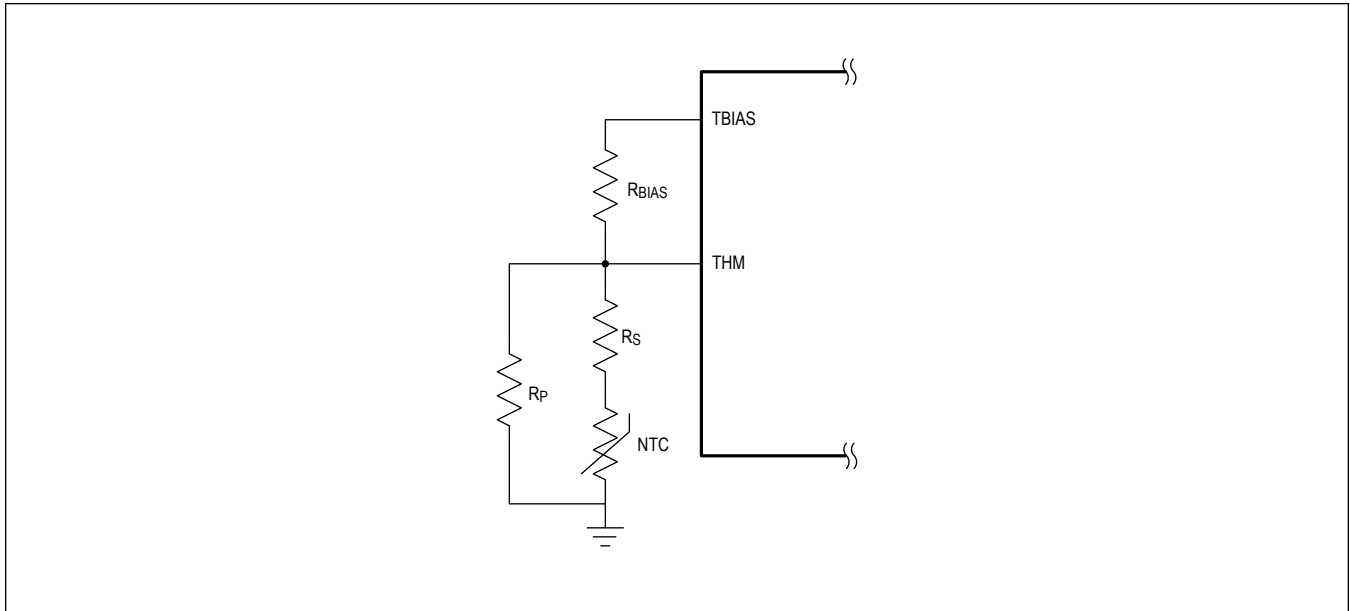

Figure 12. Thermistor Circuit with Adjusting Series and Parallel Resistors

Select values for  $R_S$  and  $R_P$  based on the information shown in [Table 10](#).

**Table 10. Example  $R_S$  and  $R_P$  Correcting Values for NTC  $\beta$  Above 3380K**

PARAMETER	UNIT	TARGET NTC CASE	CASE 1		CASE 2		CASE 3	
NTC thermistor beta	K	3380	3940		4050		4250	
25°C NTC resistance	k $\Omega$	10	10		47		100	
$R_{BIAS}$		10	10		47		100	
Adjusting parallel resistor, $R_P$		open	open	200	open	680	open	1300
Adjusting series resistor, $R_S$		short	short	0.62	short	3.3	short	9.1
$R_{NTC}$ at 1.024V <sub>COOL</sub> threshold		45.24	45.24	578.5	212.6	306.1	452.4	684.8
$R_{NTC}$ at 0.867V <sub>COOL</sub> threshold		22.61	22.61	248.8	106.3	122.7	226.1	264.7
$R_{NTC}$ at 0.459V <sub>WARM</sub> threshold		5.81	5.81	5.36	27.3	25.1	58.1	51.7
$R_{NTC}$ at 0.291V <sub>HOT</sub> threshold		3.04	3.04	2.46	14.3	112.7	30.4	22.0
$T_{ACTUAL}$ at V <sub>COOL</sub> (-10°C expected)		°C	-10.03	-5.56	-9.96	-4.82	-11.14	-3.55
$T_{ACTUAL}$ at V <sub>COOL</sub> (5°C expected)	4.98		7.66	5.76	8.10	5.33	8.86	5.94
$T_{ACTUAL}$ at V <sub>WARM</sub> (40°C expected)	40.02		37.79	39.76	37.43	39.40	36.82	39.48

**Table 10. Example  $R_S$  and  $R_P$  Correcting Values for NTC  $\beta$  Above 3380K (continued)**

$T_{ACTUAL}$ at $V_{HOT}$ (60°C expected)		60.04	54.56	60.37	53.68	60.02	52.21	60.45
--	--	-------	-------	-------	-------	-------	-------	-------

**NTC Thermistor Selection**

Popular NTC thermistor options are listed in [Table 11](#).

**Table 11. NTC Thermistors**

MANUFACTURER	PART#	$\beta$ -CONSTANT (25°C/50°C)	R ( $\Omega$ ) AT 25°C	CASE SIZE
TDK	NTCG063JF223HTBX	3380K	22k	0201
Murata	NCP03XH103F05RL	3380K	10k	0201
Murata	NCP15XH103F03RC	3380K	10k	0402
TDK	NTCG103JX103DT1	3380K	10k	0402
Cantherm	CMFX3435103JNT	3435K	10k	0402
Murata	NCP15XV103J03RC	3900K	10k	0402
Panasonic	ERT-JZEP473J	4050K	47k	0201
Panasonic	ABNTC-0402-473J-4100F-T	4100K	47k	0402
Murata	NCP15WF104F03RC	4250K	100k	0402

**Detailed Description—Analog Multiplexer**

An external ADC can be used to measure the chip's various signals for general functionality or on-the-fly power monitoring. The MUX\_SEL[3:0] bitfield controls the internal analog multiplexer responsible for connecting the proper channel to the AMUX pin. Each measurable signal is listed in [Table 12](#) with its appropriate multiplexer channel.

The voltage on the AMUX pin is a buffered output that ranges from 0V to  $V_{FS}$  (1.25V, typ). The buffer has 50 $\mu$ A of quiescent current consumption and is only active when a channel is selected (MUX\_SEL[3:0]  $\neq$  0b0000). Disable the buffer by programming MUX\_SEL[3:0] to 0b0000 when not actively converting the voltage on AMUX. The AMUX output is high-impedance while MUX\_SEL[3:0] is 0b0000.

[Table 12](#) shows how to translate the voltage signal on the AMUX pin to the value of the parameter being measured. See the [Electrical Characteristics](#) table and refer to the [Register Map](#) for more details.

**Table 12. AMUX Signal Transfer Functions**

SIGNAL	MUX_SEL[3:0]	TRANSFER FUNCTION	FULL-SCALE SIGNAL MEANING ( $V_{AMUX} = 1.25V$ )	ZERO-SCALE SIGNAL MEANING ( $V_{AMUX} = 0V$ )
CHGIN pin voltage	0b0001	$V_{CHGIN} = \frac{V_{AMUX}}{G_{VCHGIN}}$	7.5V	0V
CHGIN pin current	0b0010	$I_{CHGIN} = \frac{V_{AMUX}}{G_{ICHGIN}}$	0.475A	0A
BATT pin voltage	0b0011	$V_{BATT} = \frac{V_{AMUX}}{G_{VBATT}}$	4.6V	0V
BATT pin charging current	0b0100	$I_{BATT(CHG)} = \frac{V_{AMUX}}{V_{FS}} \times I_{FAST-CHG}$	100% of $I_{FAST-CHG}$ (CHG_CC[5:0])	0% of $I_{FAST-CHG}$

**Table 12. AMUX Signal Transfer Functions (continued)**

SIGNAL	MUX_SEL[3:0]	TRANSFER FUNCTION	FULL-SCALE SIGNAL MEANING (V <sub>AMUX</sub> = 1.25V)	ZERO-SCALE SIGNAL MEANING (V <sub>AMUX</sub> = 0V)
BATT pin discharge current	0b0101	$I_{\text{BATT(DISCHG)}} = \frac{(V_{\text{AMUX}} - V_{\text{NULL}})}{(V_{\text{FS}} - V_{\text{NULL}})} \times I_{\text{DISCHG-SCALE}}$	100% of I <sub>DISCHG-SCALE</sub> (IMON_DISCHG_SCALE[3:0])	0% of I <sub>DISCHG-SCALE</sub>
BATT pin discharge current NULL	0b0110	$V_{\text{NULL}} = V_{\text{AMUX}}$	1.25V	0V
THM pin voltage	0b0111	$V_{\text{THM}} = V_{\text{AMUX}}$	1.25V	0V
TBIAS pin voltage	0b1000	$V_{\text{TBIAS}} = V_{\text{AMUX}}$	1.25V	0V
AGND pin voltage*	0b1001	$V_{\text{AGND}} = V_{\text{AMUX}}$	1.25V	0V
SYS pin voltage	0b1010	$V_{\text{SYS}} = \frac{V_{\text{AMUX}}}{G_{\text{VSYS}}}$	4.8V	0V

\*AGND pin voltage is accessed through a 100Ω (typ) pulldown resistor.

### Measuring Battery Current

It is possible to sample the current in the BATT pin at any time or in any mode with an external ADC. For improved accuracy, the analog circuitry used for monitoring battery discharge current is different from the circuitry monitoring battery charge current. [Table 13](#) outlines how to determine the direction of battery current.

**Table 13. Battery Current Direction Decode**

MEASUREMENT	CHARGING OR DISCHARGING INDICATORS		
	CHG BIT	CHG_DTLS[3:0]	CHGIN_DTLS[1:0]
Discharging Battery Current (Positive Battery Terminal Sourcing Current)	<i>Don't care</i>	<i>Don't care</i>	0b00 0b01 0b10
Charging Battery Current (Positive Battery Terminal Sinking Current)	1	0b0001 - 0b0111	0b11

### Method for Measuring Discharging Current

- Program the multiplexer to switch to the discharge NULL measurement by changing MUX\_SEL[3:0] to 0b0110. A NULL conversion must always be performed first to cancel offsets.
- Wait the appropriate channel switching time (0.3μs, typ).
- Convert the voltage on the AMUX pin and store as V<sub>NULL</sub>.
- Program the multiplexer to switch to the battery discharge current measurement by changing MUX\_SEL[3:0] to 0b0101. A nonnulling conversion should be done immediately after a NULL conversion.
- Wait the appropriate channel switching time (0.3μs, typ).
- Convert the voltage on AMUX pin and use the following transfer function to determine the discharge current:

$$I_{\text{BATT(DISCHG)}} = \frac{(V_{\text{AMUX}} - V_{\text{NULL}})}{(V_{\text{FS}} - V_{\text{NULL}})} \times I_{\text{DISCHG-SCALE}}$$

$V_{\text{FS}}$  is 1.25V typical.  $I_{\text{DISCHG-SCALE}}$  is programmable through  $\text{IMON\_DISCHG\_SCALE}[3:0]$ . The default value is 300mA. If smaller currents are anticipated, then  $I_{\text{DISCHG-SCALE}}$  can be reduced for improved measurement accuracy.

### Method for Measuring Charging Current

- Program the multiplexer to switch to the charge current measurement by changing  $\text{MUX\_SEL}[3:0]$  to 0b0100.
- Wait the appropriate channel switching time (0.3 $\mu\text{s}$ , typ).
- Convert the voltage on the AMUX pin and use the following transfer function to determine charging current.

$$I_{\text{BATT(CHG)}} = \frac{V_{\text{AMUX}}}{V_{\text{FS}}} \times I_{\text{FAST-CHG}}$$

$V_{\text{FS}}$  is 1.25V typical.  $I_{\text{FAST-CHG}}$  the charger's fast-charge constant-current setting and is programmable through  $\text{CHG\_CC}[5:0]$ .

## Detailed Description—Linear Regulator

The IC integrates a 150mA PMOS low-dropout linear voltage regulator (LDO). Output voltage is programmable through I<sup>2</sup>C between 0.8V and 3.975V in 25mV steps using the  $\text{LDO\_VREG}[6:0]$  bitfield. The LDO features a low- $I_{\text{Q}}$  (1.5 $\mu\text{A}$ , typ) low-power mode which reduces system idle power consumption. The LDO input (INLDO) can be connected directly to SYS or supplied by an external step-down regulator for increased power efficiency. A 100 $\Omega$  (typ) active-discharge resistor is available to quickly discharge the LDO's output after the regulator has been disabled.

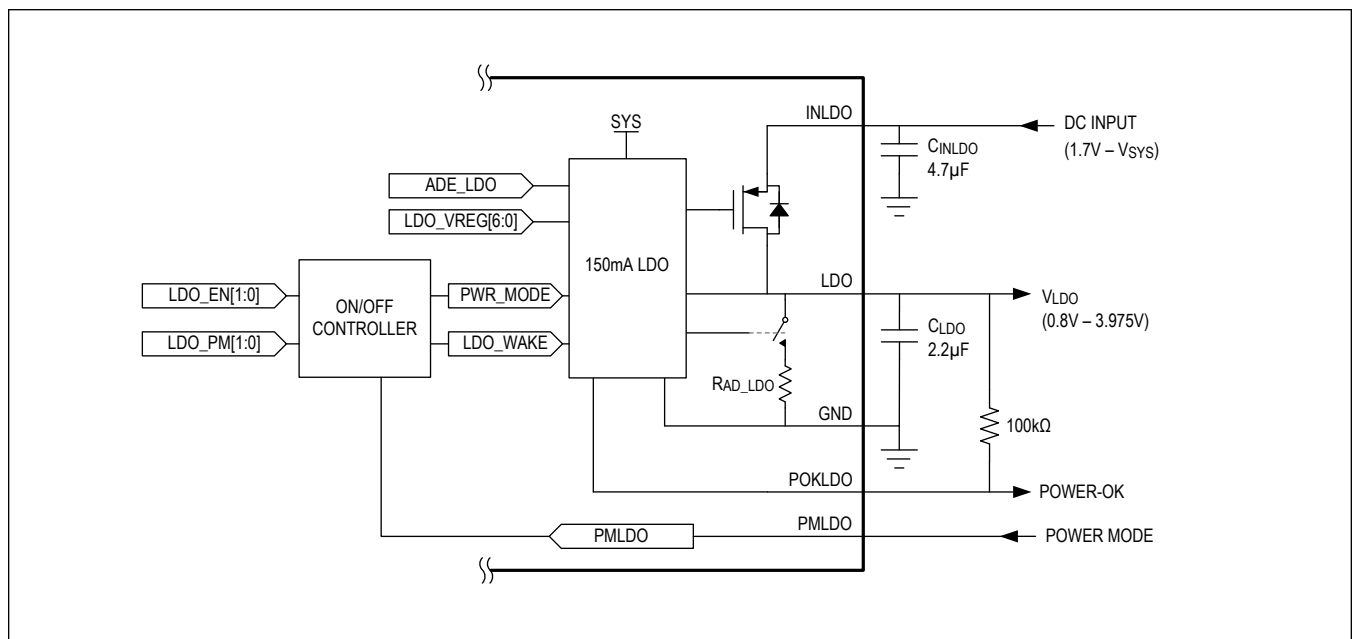

Figure 13. LDO Simplified Block Diagram

### LDO Enable Control

Force the LDO on by writing  $\text{LDO\_EN}[1:0]$  to 0b01 with I<sup>2</sup>C. The on/off controller begins the LDO power-up sequence when this bit combination is set.

Disable the LDO (force off) by writing  $\text{LDO\_EN}[1:0]$  to 0b00 with I<sup>2</sup>C. This bit combination causes the LDO power-down sequence to happen.

Setting the bits in  $\text{LDO\_EN}[1:0]$  to 0b10 causes the LDO to activate due to hardware inputs (nENLDO or CHGIN) or

special software commands. This bit combination causes the on/off controller to begin the LDO power-up sequence when:

- nENLDO is asserted for  $t_{DBNC\_nENLDO}$  (LDO\_WAKE internal flag set)
- CHGIN is inserted and debounced valid (CHGIN\_DTLS[1:0] = 0b11)
- Software caused a cold reset (SFT\_CTRL[1:0] = 0b01) and the reset actions are finished and LDO\_EN[1:0] is factory-programmed to 0b10 (SFT\_WAKE internal flag set)

The LDO deactivates regardless of LDO\_EN[1:0] when any of the following conditions are true:

- SYS undervoltage-lockout
- SYS overvoltage-lockout
- Chip over-temperature lockout
- Software causes a power-off (SFT\_CTRL[1:0] = 0b10)
- Software causes a reset (SFT\_CTRL[1:0] = 0b01)
- Software requests factory-ship mode (SFT\_CTRL[1:0] = 0b11)
- The watchdog timer is enabled and expires (WDT\_EXP internal flag set)
- Manual reset occurs (MAN\_RST internal flag set)

Consult the [On/Off Controller](#) section and [Table 1](#) of the data sheet for more details.

The reset value of the bits in LDO\_EN[1:0] is factory-programmable. Consult the [Ordering Information](#) for details.

### LDO Power Mode (PMLDO)

Program the LDO\_PM[1:0] bitfield to 0b00 to configure the LDO in low-power mode. Program 0b01 to configure the LDO for normal mode. Program 0b10 or 0b11 to enable hardware control of the power mode through the PMLDO pin. Code 0b10 enables normal mode when PMLDO is logic-high. Code 0b11 enables normal mode when PMLDO is logic-low. If the MSB of LDO\_PM[1:0] is set, then always drive the PMLDO pin to prevent mode chatter. If the MSB is not set, then the PMLDO pin is a *don't care*. See [Table 14](#) for a truth table of this behavior.

**Table 14. LDO Power Mode Truth Table**

PMLDO (PIN)	LDO_PM[1:0] (BITFIELD)	LDO POWER MODE
X	00	Low-Power
X	01	Normal
0	10	Low-Power
1	10	Normal
0	11	Normal
1	11	Low-Power

The LDO can support loads of 150mA with an  $I_{INLDO-Q}$  of 12 $\mu$ A (1.8V<sub>LDO</sub>) in normal mode. Loads of 5mA with a reduced  $I_{INLDO-Q}$  of 1.5 $\mu$ A (1.8V<sub>LDO</sub>) are supported in low-power mode.

A system similar to the block diagram in [Figure 14](#) can dynamically manage the LDO's power mode and minimize  $I_Q$  consumption. When the low-power microcontroller (U2) disables the dynamic load (U3) then the PMLDO pin is brought low indicating that the LDO goes to low-power mode. When the host enables the load, then the PMLDO pin becomes high and the LDO enters normal power mode to support the current demand of the dynamic load.

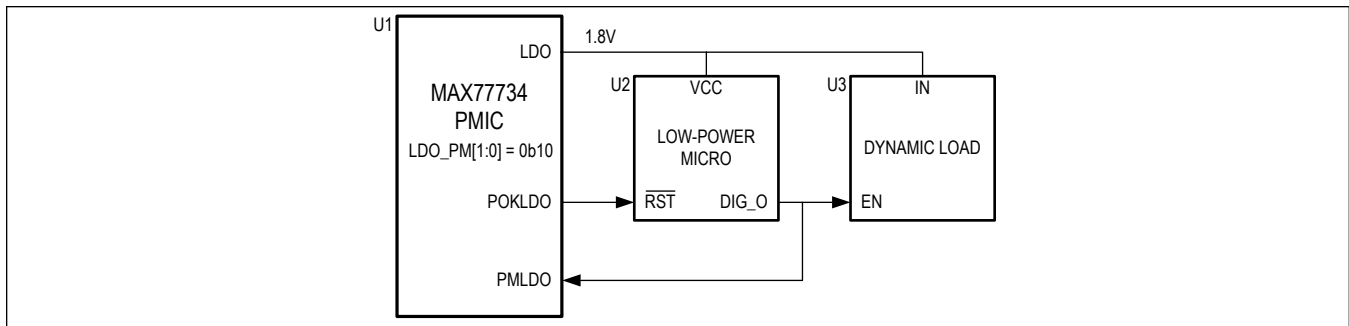

Figure 14. Dynamic LDO Power Mode Control Idea

### LDO Power-OK Output (POKLDO)

The IC features an open-drain LDO Power-OK (POKLDO) output to monitor the LDO output voltage. POKLDO requires an external pullup resistor to a voltage equal to or less than  $V_{SYS}$ . This node goes high when  $V_{LDO}$  rises above  $V_{POKLDO\_R}$  (typically 87.5% of programmed  $V_{LDO-REG}$ ) and goes low when  $V_{LDO}$  falls below  $V_{POKLDO\_F}$  (typically 84% of  $V_{LDO-REG}$ ).

POKLDO is blanked by the on/off controller during the LDO power-up and power-down sequences (Figure 2). The blanking signal holds POKLDO low regardless of  $V_{LDO}$ .

### LDO Applications Information

#### Input/Output Capacitor Selection

Bypass INLDO to GND with a minimum 10 $\mu$ F ceramic capacitor. If INLDO is connected to SYS, then a single 22 $\mu$ F bypass capacitor to GND can be used for both pins.

Bypass the LDO output to GND with a minimum 2.2 $\mu$ F ceramic capacitor that maintains 1.1 $\mu$ F of effective capacitance at bias. Larger values of LDO capacitance improve decoupling but increase inrush current during LDO startup. Refer to [Startup Rate and Inrush Current](#) for guidance on managing startup inrush current.

Ceramic capacitors with X5R or X7R dielectric are highly recommended due to their small size, low ESR, and small temperature coefficients. All ceramic capacitors derate with DC bias voltage (effective capacitance goes down as DC bias goes up). Generally, small case size capacitors derate heavily compared to larger case sizes (0603 case size performs better than 0402). Consider the effective capacitance value carefully by consulting the manufacturer's data sheet.

#### Startup Rate and Inrush Current

The startup ramp rate of the LDO can be controlled using the following equation:

$$\frac{\Delta V_{LDO}}{\Delta t} = \frac{I_{LDO-LIM}}{8 \times C_{LDO}}$$

where  $I_{LDO-LIM}$  is the output current limit of the LDO in normal mode (300mA, typ) and  $C_{LDO}$  is the LDO output capacitor (2.2 $\mu$ F minimum required).

Applications that are sensitive to inrush current from the battery should select an LDO output capacitor as close to the minimum stability requirement as possible (2.2 $\mu$ F), while at the same time, maximizing the INLDO and SYS capacitance to filter any large current spikes from BATT.

**PCB Layout Guidelines**

Careful printed circuit board (PCB) layout is necessary to achieve optimal performance. Follow these guidelines when designing the PCB:

1. Place decoupling components ( $C_{CHGIN}$ ,  $C_{SYS}$ ,  $C_{BATT}$ ,  $C_{INLDO}$ ,  $C_{LDO}$ ) close to the IC.
2. A single decoupling capacitor can be used to bypass both SYS and INLDO to GND. Use a short and wide copper flood to connect SYS and INLDO.
3. If INLDO has a different power source (other than SYS), then a separate INLDO decoupling capacitor (not drawn in [Figure 15](#)) is recommended.
4. The value of  $C_{INLDO}$  should be larger than  $C_{LDO}$ . If  $C_{LDO} = 2.2\mu\text{F}$  then choose  $C_{INLDO} = 4.7\mu\text{F}$  or greater.

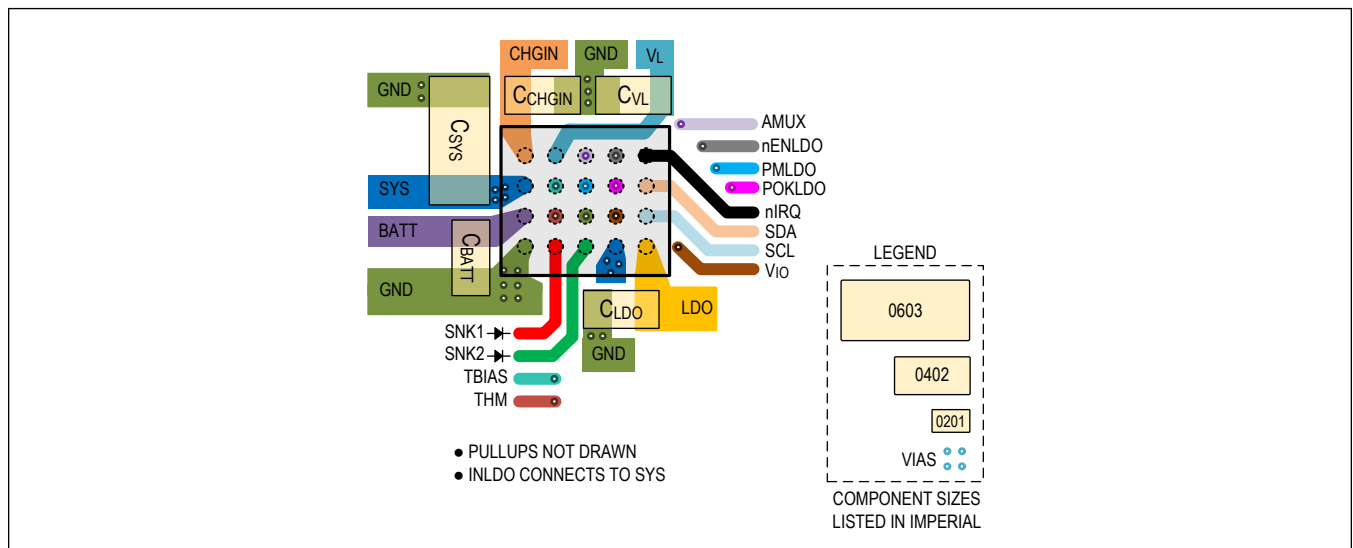

Figure 15. PCB Top-Metal and Component Layout Example

[Figure 15](#) shows an example PCB top metal layout with 0.2mm component-to-component spacing.

**Detailed Description—Dual-Channel Current Sink Driver**

The IC has a dual-channel current sink driver designed to drive LEDs in portable devices (see [Figure 16](#)). The circuit can also be used as a general-purpose current sink driver for other applications. The driver's on-time and frequency are independently programmable for each output to achieve a desired blink pattern. Alternatively, the LEDs can be continuously on (not blinking). The blink period is programmable from 0.5s to 8s, with an on-time duty cycle from 6.25% to 100%.

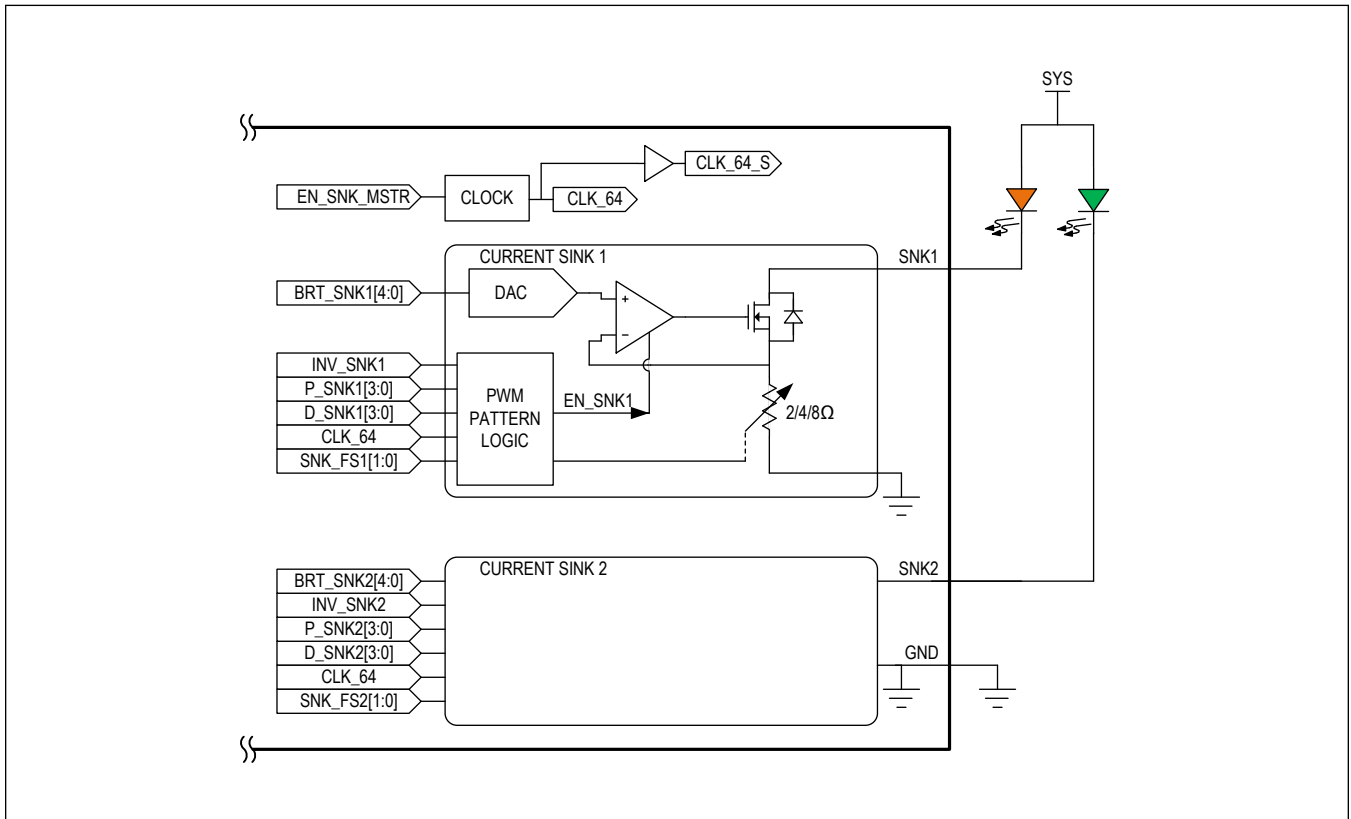

Figure 16. LED Current Sinks Functional Block Diagram

## Detailed Description—I<sup>2</sup>C Serial Interface

The IC features a revision 3.0 I<sup>2</sup>C-compatible, 2-wire serial interface consisting of a bidirectional serial data line (SDA) and a serial clock line (SCL). The IC is a slave-only device that relies on an external bus master to generate SCL. SCL clock rates from 0Hz to 3.4MHz are supported. I<sup>2</sup>C is an open-drain bus and therefore SDA and SCL require pullups.

The device's I<sup>2</sup>C communication controller implements 7-bit slave addressing. An I<sup>2</sup>C bus master initiates communication with the slave by issuing a START condition followed by the slave address. The slave address is factory programmable to one of two options (Table 15). All slave addresses not mentioned in Table 15 are not acknowledged.

The IC uses 8-bit registers with 8-bit register addressing. They support standard communication protocols: (1) Writing to a single register (2) Writing to multiple sequential registers with an automatically incrementing data pointer (3) Reading from a single register (4) Reading from multiple sequential registers with an automatically incrementing data pointer. For additional information on the I<sup>2</sup>C protocols, refer to the [MAX77734 I<sup>2</sup>C Implementer's Guide](#) and/or the I<sup>2</sup>C specification that is freely available on the internet.

**Table 15. I<sup>2</sup>C Slave Address Options**

ADDRESS	7-BIT SLAVE ADDRESS	8-BIT WRITE ADDRESS	8-BIT READ ADDRESS
Main Address (ADDR = 1)*	0x48, 0b 100 1000	0x90, 0b 1001 0000	0x91, 0b 1001 0001
Main Address (ADDR = 0)*	0x40, 0b 100 0000	0x80, 0b 1000 0000	0x81, 0b 1000 0001
Test Mode**	0x49, 0b 100 1001	0x92, 0b 1001 0010	0x93, 0b 1001 0011

\*Perform all reads and writes on the Main Address. ADDR is a factory one-time programmable (OTP) option, allowing for address changes in the event of a bus conflict. [Contact Maxim](#) for more information.

\*\*When test mode is unlocked, the additional address is acknowledged. Test mode details are confidential. If possible, leave the test mode address unallocated to allow for the rare event that debugging needs to be performed in cooperation with Maxim.

## Register Map

## MAX77734

ADDRESS	NAME	MSB							LSB
<b>Global Configuration</b>									
0x00	<a href="#">INT_GLBL[7:0]</a>	RSVD	POKLDO_I	TJAL2_R	TJAL1_R	nENLDO_R	nENLDO_F	RSVD	RSVD
0x01	<a href="#">INT_CHG[7:0]</a>	RSVD	SYS_CNFG_I	SYS_CTL_I	CHGIN_CTRL_I	TJ_REG_I	CHGIN_I	CHG_I	THM_I
0x02	<a href="#">STAT_CHG_A[7:0]</a>	RSVD	VCHGIN_MIN_S TAT	ICHGIN_LIM_STA T	VSYS_M IN_STAT	TJ_REG_STAT	THM_DTLS[2:0]		
0x03	<a href="#">STAT_CHG_B[7:0]</a>	CHG_DTLS[3:0]			CHGIN_DTLS[1:0]		CHG	TIME_S US	
0x04	<a href="#">ERCFLAG[7:0]</a>	WDT_RST	WDT_OFF	SFT_RST	SFT_OFF	MRST	SYSUVO	SYSOVL_O	TOVLD
0x05	<a href="#">STAT_GLBL[7:0]</a>	DIDM[1:0]		POKLDO_S	TJAL2_S	TJAL1_S	STAT_ENLDO	BOK	STAT_IRQ
0x06	<a href="#">INTM_GLBL[7:0]</a>	RSVD	POKLDO_IM	TJAL2_RM	TJAL1_RM	nENLDO_RM	nENLDO_FM	RSVD	RSVD
0x07	<a href="#">INT_M_CHG[7:0]</a>	RSVD	SYS_CNFG_M	SYS_CTL_M	CHGIN_CTRL_M	TJ_REG_M	CHGIN_M	CHG_M	THM_M
0x08	<a href="#">CNFG_GLBL[7:0]</a>	PU_DIS	T_MRST	BIAS_LPM	BIAS_REQ	nENLDO_MODE	DB_nENLDO	SFT_CTRL[1:0]	
0x09	<a href="#">CID[7:0]</a>	-	-	-	-	CID[3:0]			
0x0A	<a href="#">CNFG_WDT[7:0]</a>	RSVD	RSVD	WDT_PER[1:0]		WDT_MODE	WDT_CLR	WDT_EN	WDT_LOCK
<b>Charger Configuration</b>									
0x20	<a href="#">CNFG_CHG_A[7:0]</a>	THM_HOT[1:0]		THM_WARM[1:0]	THM_COOL[1:0]		THM_COLD[1:0]		
0x21	<a href="#">CNFG_CHG_B[7:0]</a>	VCHGIN_MIN[2:0]			ICHGIN_LIM[2:0]		I_PQ	CHG_EN	
0x22	<a href="#">CNFG_CHG_C[7:0]</a>	CHG_PQ[2:0]			I_TERM[1:0]	T_TOPOFF[2:0]			
0x23	<a href="#">CNFG_CHG_D[7:0]</a>	TJ_REG[2:0]			VSYS_REG[4:0]				
0x24	<a href="#">CNFG_CHG_E[7:0]</a>	CHG_CC[5:0]						T_FAST_CHG[1:0]	
0x25	<a href="#">CNFG_CHG_F[7:0]</a>	CHG_CC_JEITA[5:0]						THM_EN	RSVD
0x26	<a href="#">CNFG_CHG_G[7:0]</a>	CHG_CV[5:0]						USBS	RSVD
0x27	<a href="#">CNFG_CHG_H[7:0]</a>	CHG_CV_JEITA[5:0]						RSVD	RSVD
0x28	<a href="#">CNFG_CHG_I[7:0]</a>	IMON_DISCHG_SCALE[3:0]				MUX_SEL[3:0]			
<b>LDO Configuration</b>									
0x30	<a href="#">CNFG_LDO_A[7:0]</a>	ADE_LDO	LDO_VREG[6:0]						
0x31	<a href="#">CNFG_LDO_B[7:0]</a>					LDO_PM[1:0]	LDO_EN[1:0]		
<b>Current Sinks Configuration</b>									
0x40	<a href="#">CNFG_SNK1_A[7:0]</a>	SNK_FS1[1:0]		INV_SNK1	BRT_SNK1[4:0]				
0x41	<a href="#">CNFG_SNK1_B[7:0]</a>	P_SNK1[3:0]				D_SNK1[3:0]			
0x42	<a href="#">CNFG_SNK2_A[7:0]</a>	SNK_FS2[1:0]		INV_SNK2	BRT_SNK2[4:0]				

ADDRESS	NAME	MSB						LSB
0x43	<a href="#">CNFG_SNK2_B[7:0]</a>	P_SNK2[3:0]			D_SNK2[3:0]			
0x44	<a href="#">CNFG_SNK_TOP[7:0]</a>	-	-	-	-	-	-	CLK_64_ S EN_SNK_ MSTR

## Register Details

### [INT\\_GLBL \(0x00\)](#)

BIT	7	6	5	4	3	2	1	0
<b>Field</b>	RSVD	POKLDO_I	TJAL2_R	TJAL1_R	nENLDO_R	nENLDO_F	RSVD	RSVD
<b>Reset</b>	0b0	0b0	0b0	0b0	0b0	0b0	0b0	0b0
<b>Access Type</b>	Read Clears All	Read Clears All	Read Clears All	Read Clears All	Read Clears All	Read Clears All	Read Clears All	Read Clears All

BITFIELD	BITS	DESCRIPTION	DECODE
RSVD	7	Reserved. Reads back 0.	N/A
POKLDO_I	6	POKLDO Interrupt	0 = POKLDO_S has not changed since the last time this bit was read. 1 = POKLDO_S has changed since the last time this bit was read.
TJAL2_R	5	Thermal Alarm 2 Rising Interrupt	0 = The junction temperature has not risen above TJAL2 since the last time this bit was read. 1 = The junction temperature has risen above TJAL2 since the last time this bit was read.
TJAL1_R	4	Thermal Alarm 1 Rising Interrupt	0 = The junction temperature has not risen above TJAL1 since the last time this bit was read. 1 = The junction temperature has risen above TJAL1 since the last time this bit was read.
nENLDO_R	3	nENLDO Rising Interrupt	0 = No nENLDO rising edges have occurred since the last time this bit was read. 1 = A nENLDO rising edge as occurred since the last time this bit was read.
nENLDO_F	2	nENLDO Falling Interrupt	0 = No nENLDO falling edges have occurred since the last time this bit was read. 1 = A nENLDO falling edge as occurred since the last time this bit was read.
RSVD	1	Reserved. Reads back 0.	N/A
RSVD	0	Reserved. Reads back 0.	N/A

### [INT\\_CHG \(0x01\)](#)

BIT	7	6	5	4	3	2	1	0
<b>Field</b>	RSVD	SYS_CNFG_I	SYS_CTRL_I	CHGIN_CT RL_I	TJ_REG_I	CHGIN_I	CHG_I	THM_I
<b>Reset</b>	0b1	0b0	0b0	0b0	0b0	0b0	0b0	0b0
<b>Access Type</b>	Read Clears All	Read Clears All	Read Clears All	Read Clears All	Read Clears All	Read Clears All	Read Clears All	Read Clears All

BITFIELD	BITS	DESCRIPTION	DECODE
RSVD	7	Reserved. Reads back 0.	N/A

BITFIELD	BITS	DESCRIPTION	DECODE
SYS_CNFG_I	6	System Voltage Configuration Error Interrupt. Goes high when $V_{SYS-REG}$ and $V_{FAST-CHG}$ are programmed too close to each other. Reads back 1 when the bit combination in CHG_CV[5:0] or CHG_CV_JEITA[5:0] has been forced to change (reduce) to ensure $V_{SYS-REG} = V_{FAST-CHG} + 200mV$ .	0 = No configuration error since the last time this bit was read. 1 = The bits in CHG_CV[5:0] have been forced to change to ensure $V_{SYS-REG}$ is 200mV above $V_{FAST-CHG}$ .
SYS_CTRL_I	5	Minimum System Voltage Regulation Loop Related Interrupt. Signals a change in VSYS_MIN_STAT.	0 = VSYS_MIN_STAT has not changed since the last time this bit was read. 1 = VSYS_MIN_STAT has changed.
CHGIN_CTRL_I	4	CHGIN Control-Loop Related Interrupt. Signals a change in the minimum input voltage regulation loop (VCHGIN_MIN_STAT) or the input current-limit loop (ICHGIN_LIM_STAT).	0 = Neither VCHGIN_MIN_STAT nor ICHGIN_LIM_STAT has changed since the last time this bit was read. 1 = VCHGIN_MIN_STAT or ICHGIN_LIM_STAT has changed.
TJ_REG_I	3	Die Junction Temperature Regulation Interrupt. Signals a change in the die temperature regulation loop (TJ_REG_STAT).	0 = TJ_REG_STAT has not changed since the last time this bit was read. 1 = TJ_REG_STAT has changed.
CHGIN_I	2	CHGIN Related Interrupt. Signals a change in CHGIN_DTLS[1:0].	0 = The bits in CHGIN_DTLS[1:0] have not changed since the last time this bit was read. 1 = The bits in CHGIN_DTLS[1:0] have changed.
CHG_I	1	Charger Related Interrupt. Signals a change in CHG_DTLS[3:0].	0 = The bits in CHG_DTLS[3:0] have not changed since the last time this bit was read. 1 = The bits in CHG_DTLS[3:0] have changed.
THM_I	0	Thermistor Related Interrupt. Signals a change in THM_DTLS[2:0].	0 = The bits in THM_DTLS[2:0] have not changed since the last time this bit was read. 1 = The bits in THM_DTLS[2:0] have changed.

**STAT\_CHG\_A (0x02)**

BIT	7	6	5	4	3	2	1	0
Field	RSVD	VCHGIN_MIN_STAT	ICHGIN_LIM_STAT	VSYS_MIN_STAT	TJ_REG_STAT	THM_DTLS[2:0]		
Reset	0b0	0b0	0b0	0b0	0b0	0b000		
Access Type	Read Only	Read Only	Read Only	Read Only	Read Only	Read Only		

BITFIELD	BITS	DESCRIPTION	DECODE
RSVD	7	Reserved. Reads back 0.	N/A
VCHGIN_MIN_STAT	6	Minimum Input Voltage Regulation Loop Status	0 = The minimum CHGIN voltage regulation loop has not engaged. 1 = The loop has engaged to reduce CHGIN current to regulate $V_{CHGIN} \geq V_{CHGIN-MIN}$ .
ICHGIN_LIM_STAT	5	Input Current-Limit Loop Status	0 = The CHGIN current-limit loop is not engaged. 1 = The loop has engaged to regulate $I_{CHGIN} \leq I_{CHGIN-LIM}$ .
VSYS_MIN_STAT	4	Minimum System Voltage Regulation Loop Status	0 = The minimum system voltage regulation loop is not engaged. 1 = The loop has engaged to regulate $V_{SYS} \geq V_{SYS-MIN}$ .

BITFIELD	BITS	DESCRIPTION	DECODE
TJ_REG_ST AT	3	Maximum Junction Temperature Regulation Loop Status	0 = The maximum junction temperature regulation loop is not engaged. 1 = The loop has engaged and is reducing charge current to limit die temperature.
THM_DTLS	2:0	Battery Temperature Details	0b000 = Thermistor is disabled (THM_EN = 0). 0b001 = Battery is cold as programmed by THM_COLD[1:0]. 0b010 = Battery is cool as programmed by THM_COOL[1:0]. 0b011 = Battery is warm as programmed by THM_WARM[1:0]. 0b100 = Battery is hot as programmed by THM_HOT[1:0]. 0b101 = Battery temperature is normal as programmed by CNFG_CHG_A register. 0b110-0b111 = Reserved.

**STAT\_CHG\_B (0x03)**

BIT	7	6	5	4	3	2	1	0
Field	CHG_DTLS[3:0]				CHGIN_DTLS[1:0]		CHG	TIME_SUS
Reset	0b0000				0b00		0b0	0b0
Access Type	Read Only				Read Only		Read Only	Read Only

BITFIELD	BITS	DESCRIPTION	DECODE
CHG_DTLS	7:4	Charger Details. Indicates the current state of the charger.	0b0000 = Charger off. 0b0001 = Prequalification mode. 0b0010 = Fast-charge constant-current (CC) mode. 0b0011 = JEITA-modified fast-charge constant-current mode. 0b0100 = Fast-charge constant-voltage (CV) mode. 0b0101 = JEITA-modified fast-charge constant-voltage mode. 0b0110 = Top-off mode. 0b0111 = JEITA-modified top-off mode. 0b1000 = Done. 0b1001 = JEITA-modified done (done was entered through the JEITA-modified fast-charge states). 0b1010 = Prequalification timer fault. 0b1011 = Fast-charge timer fault. 0b1100 = Battery temperature fault. 0b1101-0b1111 = Reserved.
CHGIN_DTLS	3:2	CHGIN Status Details	0b00 = CHGIN voltage is below the UVLO threshold ( $V_{CHGIN\_UVLO}$ ) or USB suspended (USBS = 1). 0b01 = CHGIN voltage is above the OVP threshold ( $V_{CHGIN\_OVP}$ ). 0b10 = The CHGIN input is being debounced (no power drawn from CHGIN during debounce). 0b11 = The CHGIN input is debounced and valid.
CHG	1	Quick Charger Status	0 = Charging is not happening. 1 = Charging is happening.

BITFIELD	BITS	DESCRIPTION	DECODE
TIME_SUS	0	Time Suspend Indicator. The fast-charge safety timer suspends if any of the following are true: charge current has dropped below 20% of I <sub>FAST-CHG</sub> while the charger state machine is in FAST CHARGE (CC) state, the charger is in supplement mode, or the charger state machine is in BATTERY TEMPERATURE FAULT mode.	0 = Charger's timers are not active or not suspended. 1 = Charger's active timer suspended.

**ERCFLAG (0x04)**

BIT	7	6	5	4	3	2	1	0
<b>Field</b>	WDT_RST	WDT_OFF	SFT_RST	SFT_OFF	MRST	SYSUVLO	SYSOVLO	TOVLD
<b>Reset</b>	0b0	0b0	0b0	0b0	0b0	0b0	0b0	0b0
<b>Access Type</b>	Read Clears All	Read Clears All	Read Clears All	Read Clears All	Read Clears All	Read Clears All	Read Clears All	Read Clears All

BITFIELD	BITS	DESCRIPTION	DECODE
WDT_RST	7	Watchdog Timer Reset Flag. This bit sets when the watchdog timer expires and causes a power-reset (WTD_EXP = 1 and WTD_MODE = 1).	0 = Watchdog timer has not caused a power-reset since the last time this bit was read. 1 = Watchdog timer has expired and caused a power-reset since the last time this bit was read.
WDT_OFF	6	Watchdog Timer OFF Flag. This bit sets when the watchdog timer expires and causes a power-off (WTD_EXP = 1 and WTD_MODE = 0).	0 = Watchdog timer has not caused a power-off since the last time this bit was read. 1 = Watchdog timer has expired and caused a power-off since the last time this bit was read.
SFT_RST	5	Software Reset Flag. This bit sets when an I <sup>2</sup> C write causes a power-reset (SFT_RST[1:0] = 0b01).	0 = No software caused power-reset since the last time this bit was read. 1 = Software has caused a power-reset since the last time this bit was read.
SFT_OFF	4	Software OFF Flag. This bit sets when an I <sup>2</sup> C write causes a power-off (SFT_CTRL[1:0] = 0b10).	0 = No software caused power-off since the last time this bit was read. 1 = Software has caused a power-off since the last time this bit was read.
MRST	3	Manual Reset Timer Flag. This bit sets when a manual reset event (MAN_RST = 1) causes a power reset.	0 = Manual reset has not caused power-reset since the last time this bit was read. 1 = Manual reset has caused power-reset since the last time this bit was read.
SYSUVLO	2	SYS Domain Undervoltage-Lockout Flag. This bit sets when the SYS domain voltage falls below V <sub>SYSUVLO</sub> and causes a power-off.	0 = SYS domain undervoltage lockout has not caused a power-off since the last time this bit was read. 1 = SYS domain undervoltage lockout has caused a power-off since the last time this bit was read.
SYSOVLO	1	SYS Domain Overvoltage-Lockout Flag. This bit sets when the SYS domain voltage rises above V <sub>SYSOVLO</sub> and causes a power-off.	0 = SYS domain overvoltage lockout has not caused a power-off since the last time this bit was read. 1 = SYS domain overvoltage lockout has caused a power-off since the last time this bit was read.
TOVLD	0	Thermal Overload Flag. This bit sets when the junction temperature exceeds 165°C and causes a power-off.	0 = Thermal overload has not caused a power-off since the last time this bit was read. 1 = Thermal overload has caused a power-off since the last time this bit was read.

[STAT\\_GLBL \(0x05\)](#)

BIT	7	6	5	4	3	2	1	0
Field	DIDM[1:0]		POKLDO_S	TJAL2_S	TJAL1_S	STAT_ENLDO	BOK	STAT_IRQ
Reset	0b10		0b0	0b0	0b0	0b0	0b0	0b0
Access Type	Read Only		Read Only	Read Only	Read Only	Read Only	Read Only	Read Only

BITFIELD	BITS	DESCRIPTION	DECODE
DIDM	7:6	Device Identification Bits for Metal Options	0b00 = Reserved for future use. 0b01 = Reserved for future use. 0b10 = MAX77734 0b11 = Reserved for future use
POKLDO_S	5	LDO Power-OK Status. Continuous software mirror of the POKLDO pin.	0 = POKLDO is low 1 = POKLDO is high (Hi-Z)
TJAL2_S	4	Thermal Alarm 2 Status	0 = The junction temperature is less than T <sub>JAL2</sub> 1 = The junction temperature is greater than T <sub>JAL2</sub>
TJAL1_S	3	Thermal Alarm 1 Status	0 = The junction temperature is less than T <sub>JAL1</sub> 1 = The junction temperature is greater than T <sub>JAL1</sub>
STAT_ENLDO	2	Debounced Status for the nENLDO input	0 = nENLDO is not asserted (logic high) 1 = nENLDO is asserted (logic low)
BOK	1	System Bias OK Status Bit	0 = Bias not ready or not enabled. 1 = Bias enabled and ready.
STAT_IRQ	0	Interrupt Status. Continuous <i>inverted</i> software mirror of the nIRQ pin as if all interrupts were unmasked.	0 = No interrupts pending. nIRQ would be high if all interrupts were unmasked. 1 = Interrupts pending. nIRQ would be low if all interrupts were unmasked.

[INTM\\_GLBL \(0x06\)](#)

BIT	7	6	5	4	3	2	1	0
Field	RSVD	POKLDO_I M	TJAL2_RM	TJAL1_RM	nENLDO_R M	nENLDO_F M	RSVD	RSVD
Reset	0b0	0b1	0b1	0b1	0b1	0b1	0b0	0b0
Access Type	Write, Read	Write, Read	Write, Read	Write, Read	Write, Read	Write, Read	Write, Read	Write, Read

BITFIELD	BITS	DESCRIPTION	DECODE
RSVD	7	Reserved. Bit is a <i>don't care</i> .	N/A
POKLDO_IM	6	POKLDO_I Interrupt Mask. Setting this bit prevents the POKLDO_I bit from causing hardware interrupts.	0 = POKLDO_I is not masked. 1 = POKLDO_I is masked.
TJAL2_RM	5	Thermal Alarm 2 Rising Interrupt Mask. Setting this bit prevents the TJAL2_R bit from causing hardware interrupts.	0 = TJAL2_R is not masked. 1 = TJAL2_R is masked.
TJAL1_RM	4	Thermal Alarm 1 Rising Interrupt Mask. Setting this bit prevents the TJAL1_R bit from causing hardware interrupts.	0 = TJAL1_R is not masked. 1 = TJAL1_R is masked.
nENLDO_RM	3	nENLDO Rising Interrupt Mask. Setting this bit prevents the nENLDO_R bit from causing hardware interrupts.	0 = nENLDO_R is unmasked. 1 = nENLDO_R is masked.

BITFIELD	BITS	DESCRIPTION	DECODE
nENLDO_FM	2	nENLDO Falling Interrupt Mask. Setting this bit prevents the nENLDO_F bit from causing hardware interrupts.	0 = nENLDO_F is not masked. 1 = nENLDO_F is masked.
RSVD	1	Reserved. Bit is a <i>don't care</i> .	N/A
RSVD	0	Reserved. Bit is a <i>don't care</i> .	N/A

**INT\_M\_CHG (0x07)**

BIT	7	6	5	4	3	2	1	0
Field	RSVD	SYS_CNFG_M	SYS_CTRL_M	CHGIN_CTRL_M	TJ_REG_M	CHGIN_M	CHG_M	THM_M
Reset	0b1	0b1	0b1	0b1	0b1	0b1	0b1	0b1
Access Type	Write, Read	Write, Read	Write, Read	Write, Read	Write, Read	Write, Read	Write, Read	Write, Read

BITFIELD	BITS	DESCRIPTION	DECODE
RSVD	7	Reserved. Bit is a <i>don't care</i> .	N/A
SYS_CNFG_M	6	Setting this bit prevents the SYS_CNFG_I bit from causing hardware interrupts.	0 = SYS_CNFG_I is not masked. 1 = SYS_CNFG_I is masked.
SYS_CTRL_M	5	Setting this bit prevents the SYS_CTRL_I bit from causing hardware interrupts.	0 = SYS_CTRL_I is not masked. 1 = SYS_CTRL_I is masked.
CHGIN_CTRL_M	4	Setting this bit prevents the CHGIN_CTRL_I bit from causing hardware interrupts.	0 = CHGIN_CTRL_I is not masked. 1 = CHGIN_CTRL_I is masked.
TJ_REG_M	3	Setting this bit prevents the TJ_REG_I bit from causing hardware interrupts.	0 = TJ_REG_I is not masked. 1 = TJ_REG_I is masked.
CHGIN_M	2	Setting this bit prevents the CHGIN_I bit from causing hardware interrupts.	0 = CHGIN_I is not masked. 1 = CHGIN_I is masked.
CHG_M	1	Setting this bit prevents the CHG_I bit from causing hardware interrupts.	0 = CHG_I is not masked. 1 = CHG_I is masked.
THM_M	0	Setting this bit prevents the THM_I bit from causing hardware interrupts.	0 = THM_I is not masked. 1 = THM_I is masked.

**CNFG\_GLBL (0x08)**

BIT	7	6	5	4	3	2	1	0
Field	PU_DIS	T_MRST	BIAS_LPM	BIAS_REQ	nENLDO_M ODE	DB_nENLDO	SFT_CTRL[1:0]	
Reset	0b0	OTP	0b1	0b0	OTP	OTP	0b00	
Access Type	Write, Read	Write, Read	Write, Read	Write, Read	Write, Read	Write, Read	Write, Read	

BITFIELD	BITS	DESCRIPTION	DECODE
PU_DIS	7	nENLDO Internal Pullup Resistor Control to V <sub>CCINT</sub>	0 = 200kΩ pullup resistor for momentary push-buttons 1 = 10MΩ pullup resistor for persistent slide-switches
T_MRST	6	Sets the Manual Reset Time (t <sub>MRST</sub> )	0 = 8 seconds 1 = 16 seconds

BITFIELD	BITS	DESCRIPTION	DECODE
BIAS_LPM	5	System Bias Low-Power Mode Software Request	0 = Bias requested to be in normal-power mode whenever it is enabled. 1 = Bias requested to be in low-power mode whenever it is enabled.
BIAS_REQ	4	System Bias Enable Software Request	0 = Bias not requested on by software. 1 = Bias forced on by software.
nENLDO_MODE	3	nENLDO (ONKEY) Default Configuration Mode	0 = Push-button mode 1 = Slide-switch mode
DB_nENLDO	2	Debounce Timer for the nENLDO pin	0 = 200 $\mu$ s debounce 1 = 30ms debounce
SFT_CTRL	1:0	Software Control Functions	0b00 = No Action 0b01 = Software Reset. Causes a power-reset. The IC powers down, configuration registers reset (SYSRST), and the IC powers up and turns the LDO on again. 0b10 = Software Off. The IC powers down, configuration registers reset, and the IC remains off and waits for a wake-up event to turn on again. 0b11 = Factory-Ship Mode Enter (FSM). The IC powers down, configuration registers reset, and the internal BATT to SYS switch opens. The device remains this way until a factory-ship mode exit event occurs.

**CID (0x09)**

BIT	7	6	5	4	3	2	1	0
Field	–	–	–	–	CID[3:0]			
Reset	–	–	–	–	OTP			
Access Type	–	–	–	–	Read Only			

BITFIELD	BITS	DESCRIPTION	DECODE
CID	3:0	Chip Identification Code for OTP Options	Varies. See the <i>Factory Options</i> section for more details.

**CNFG\_WDT (0x0A)**

BIT	7	6	5	4	3	2	1	0
Field	RSVD	RSVD	WDT_PER[1:0]		WDT_MOD E	WDT_CLR	WDT_EN	WDT_LOC K
Reset	0b0	0b0	0b11		0b0	0b0	OTP	OTP
Access Type	Write, Read	Write, Read	Write, Read		Write, Read	Write 1 to Clear, Read	Write, Read	Read Only

BITFIELD	BITS	DESCRIPTION	DECODE
RSVD	7	Reserved. Bit is a <i>don't care</i> .	N/A
RSVD	6	Reserved. Bit is a <i>don't care</i> .	N/A
WDT_PER	5:4	Watchdog Timer Period. Sets $t_{WD}$ . Watchdog timer is reset to the programmed value as soon as this bitfield is changed.	0b00 = 16 seconds 0b01 = 32 seconds 0b10 = 64 seconds 0b11 = 128 seconds

BITFIELD	BITS	DESCRIPTION	DECODE
WDT_MODE	3	Watchdog Timer Expired Action. Determines what the IC does after the watchdog timer expires.	0 = Watchdog timer expire causes power-off. 1 = Watchdog timer expire causes power-reset.
WDT_CLR	2	Watchdog Timer Clear Control. Set this bit to feed (reset) the watchdog timer.	0 = Watchdog timer period is not reset. 1 = Watchdog timer is reset back to $t_{WD}$ .
WDT_EN	1	Watchdog Timer Enable. Write protected depending on WDT_LOCK.	0 = Watchdog timer is not enabled. WDT_EXP = 0 always. 1 = Watchdog timer is enabled. If the timer expires without being fed (reset) then WDT_EXP = 1.
WDT_LOCK	0	Factory-Set Safety Bit for the Watchdog Timer. Determines if the timer can be disabled through WDT_EN or not.	0 = Watchdog timer can be enabled and disabled with WDT_EN. 1 = Watchdog timer can not be disabled with WDT_EN. (WDT_EN can still be used to enable the watchdog timer.)

**CNFG\_CHG\_A (0x20)**

BIT	7	6	5	4	3	2	1	0
Field	THM_HOT[1:0]		THM_WARM[1:0]		THM_COOL[1:0]		THM_COLD[1:0]	
Reset	0b00		0b00		0b11		0b11	
Access Type	Write, Read		Write, Read		Write, Read		Write, Read	

BITFIELD	BITS	DESCRIPTION	DECODE
THM_HOT	7:6	Sets the $V_{HOT}$ JEITA Temperature Threshold	0b00 = 0.411V 0b01 = 0.367V 0b10 = 0.327V 0b11 = 0.291V
THM_WARM	5:4	Sets the $V_{WARM}$ JEITA Temperature Threshold	0b00 = 0.511V 0b01 = 0.459V 0b10 = 0.411V 0b11 = 0.367V
THM_COOL	3:2	Sets the $V_{COOL}$ JEITA Temperature Threshold	0b00 = 0.923V 0b01 = 0.867V 0b10 = 0.807V 0b11 = 0.747V
THM_COLD	1:0	Sets the $V_{COLD}$ JEITA Temperature Threshold	0b00 = 1.024V 0b01 = 0.976V 0b10 = 0.923V 0b11 = 0.867V

**CNFG\_CHG\_B (0x21)**

BIT	7	6	5	4	3	2	1	0
Field	VCHGIN_MIN[2:0]			ICHGIN_LIM[2:0]			I_PQ	CHG_EN
Reset	0b000			0b000			0b0	OTP
Access Type	Write, Read			Write, Read			Write, Read	Write, Read

BITFIELD	BITS	DESCRIPTION	DECODE
VCHGIN_MIN	7:5	Sets the Minimum CHGIN Regulation Voltage (VCHGIN-MIN)	0b000 = 4.0V 0b001 = 4.1V 0b010 = 4.2V 0b011 = 4.3V 0b100 = 4.4V 0b101 = 4.5V 0b110 = 4.6V 0b111 = 4.7V
ICHGIN_LIM	4:2	Sets the CHGIN Input Current Limit (ICHGIN-LIM)	This bitfield decoding changes depending on factory option. See Table 8 for details. 0b000 = 95mA/475mA 0b001 = 190mA/380mA 0b010 = 285mA 0b011 = 380mA/190mA 0b100-0b111 = 475mA/95mA
I_PQ	1	Sets the prequalification charge current (I <sub>PQ</sub> ) as a percentage of I <sub>FAST-CHG</sub> .	0 = 10% 1 = 20%
CHG_EN	0	Charger enable	0 = Disabled 1 = Enabled

**CNFG\_CHG\_C (0x22)**

BIT	7	6	5	4	3	2	1	0
Field	CHG_PQ[2:0]			I_TERM[1:0]		T_TOPOFF[2:0]		
Reset	0b111			0b11		0b000		
Access Type	Write, Read			Write, Read		Write, Read		

BITFIELD	BITS	DESCRIPTION	DECODE
CHG_PQ	7:5	Sets the Battery Prequalification Voltage Threshold (V <sub>PQ</sub> )	0b000 = 2.3V 0b001 = 2.4V 0b010 = 2.5V 0b011 = 2.6V 0b100 = 2.7V 0b101 = 2.8V 0b110 = 2.9V 0b111 = 3.0V
I_TERM	4:3	Sets the Battery Charge Termination Current (I <sub>TERM</sub> ) as a Percentage of I <sub>FAST-CHG</sub>	0b00 = 5% 0b01 = 7.5% 0b10 = 10% 0b11 = 15%
T_TOPOFF	2:0	Sets the Top-Off Timer Value (t <sub>TO</sub> )	0b000 = 0 minutes 0b001 = 5 minutes 0b010 = 10 minutes 0b011 = 15 minutes 0b100 = 20 minutes 0b101 = 25 minutes 0b110 = 30 minutes 0b111 = 35 minutes

[CNFG\\_CHG\\_D \(0x23\)](#)

BIT	7	6	5	4	3	2	1	0
Field	TJ_REG[2:0]				VSYS_REG[4:0]			
Reset	0b000				0b10000			
Access Type	Write, Read				Write, Read			

BITFIELD	BITS	DESCRIPTION	DECODE
TJ_REG	7:5	Sets the Die Junction Temperature Regulation Point (T <sub>J-REG</sub> )	0b000 = 60°C 0b001 = 70°C 0b010 = 80°C 0b011 = 90°C 0b100-0b111 = 100°C
VSYS_REG	4:0	Sets the System Voltage Regulation Point While CHGIN is Valid (V <sub>SYSTEM-REG</sub> ). This 5-bit configuration is a linear transfer function that starts at 4.1V and ends at 4.8V, with 25mV increments.	0b00000 = 4.100V 0b00001 = 4.125V 0b00010 = 4.150V ... 0b10000 = 4.500V ... 0b11010 = 4.750V 0b11011 = 4.775V 0b11100-0b11111 = 4.800V

[CNFG\\_CHG\\_E \(0x24\)](#)

BIT	7	6	5	4	3	2	1	0
Field	CHG_CC[5:0]						T_FAST_CHG[1:0]	
Reset	0b000001						0b01	
Access Type	Write, Read						Write, Read	

BITFIELD	BITS	DESCRIPTION	DECODE
CHG_CC	7:2	Sets the Fast-Charge Constant Current Value (I <sub>FAST-CHG</sub> ). This 6-bit configuration is a linear transfer function that starts at 7.5mA and ends at 300mA, with 7.5mA increments.	0b000000 = 7.5mA 0b000001 = 15mA ... 0b100111-0b111111 = 300mA
T_FAST_CHG	1:0	Sets the Fast-Charge Safety Timer (t <sub>FC</sub> )	0b00 = timer disabled 0b01 = 3 hours 0b10 = 5 hours 0b11 = 7 hours

[CNFG\\_CHG\\_F \(0x25\)](#)

BIT	7	6	5	4	3	2	1	0
Field	CHG_CC_JEITA[5:0]						THM_EN	RSVD
Reset	0b000001						0b0	0b0
Access Type	Write, Read						Write, Read	Write, Read

BITFIELD	BITS	DESCRIPTION	DECODE
CHG_CC_JE ITA	7:2	Sets I <sub>FAST-CHG_JEITA</sub> for when the battery is either cool or warm as defined by the T <sub>COOL</sub> and T <sub>WARM</sub> temperature thresholds. This register is a <i>don't care</i> if the battery temperature is normal or if THM_EN = 0.  This 6-bit configuration is a linear transfer function that starts at 7.5mA and ends at 300mA, with 7.5mA increments.	0b000000 = 7.5mA 0b000001 = 15mA ... 0b100111-0b111111 = 300mA
THM_EN	1	Thermistor Enable. Setting this bit causes the charger to enable the thermistor bias (TBIAS) and continuously monitor battery temperature. Does not collide with MUX_SEL[3:0] settings 0x7 or 0x8.	0 = Disabled 1 = Enabled
RSVD	0	Reserved Control Bit. Write to 0.	N/A

**CNFG\_CHG\_G (0x26)**

BIT	7	6	5	4	3	2	1	0
Field	CHG_CV[5:0]						USBS	RSVD
Reset	0b000000						0b0	0b0
Access Type	Write, Read						Write, Read	Write, Read

BITFIELD	BITS	DESCRIPTION	DECODE
CHG_CV	7:2	Sets fast-charge battery regulation voltage (V <sub>FAST-CHG</sub> ). Internal logic clamps the maximum V <sub>FAST-CHG</sub> value to 200mV less than V <sub>SYS-REG</sub> . This 6-bit configuration is a linear transfer function that starts at 3.6V and ends at 4.6V, with 25mV increments.	0b000000 = 3.600V 0b000001 = 3.625V ... 0b1010000-0b1111111 = 4.6V
USBS	1	Setting this bit places CHGIN in USB suspend mode. CHGIN can not draw power from an external source while in USB suspend mode.	0 = CHGIN is not suspended. 1 = CHGIN is suspended.
RSVD	0	Reserved. Bit is a <i>don't care</i> .	N/A

**CNFG\_CHG\_H (0x27)**

BIT	7	6	5	4	3	2	1	0
Field	CHG_CV_JEITA[5:0]						RSVD	RSVD
Reset	0b000000						0b0	0b0
Access Type	Write, Read						Write, Read	Write, Read

BITFIELD	BITS	DESCRIPTION	DECODE
CHG_CV_JE ITA	7:2	Sets $V_{FAST-CHG\_JEITA}$ for when the battery is either cool or warm as defined by the $T_{COOL}$ and $T_{WARM}$ temperature thresholds. This register is a <i>don't care</i> if the battery temperature is normal or if $THM\_EN = 0$ . Internal logic clamps the maximum $V_{FAST-CHG\_JEITA}$ value to 200mV less than $V_{SYS-REG}$ . This 6-bit configuration is a linear transfer function that starts at 3.6V and ends at 4.6V, with 25mV increments.	0b000000 = 3.600V 0b000001 = 3.625V ... 0b1010000-0b111111 = 4.6V
RSVD	1	Reserved. Bit is a <i>don't care</i> .	N/A
RSVD	0	Reserved. Bit is a <i>don't care</i> .	N/A

**CNFG\_CHG\_I (0x28)**

BIT	7	6	5	4	3	2	1	0
Field	IMON_DISCHG_SCALE[3:0]				MUX_SEL[3:0]			
Reset	0b1111				0b0000			
Access Type	Write, Read				Write, Read			

BITFIELD	BITS	DESCRIPTION	DECODE
IMON_DISC HG_SCALE	7:4	Selects the battery discharge current full-scale current value. This 4-bit configuration starts at 8.2 and ends at 300mA.	0b0000 = 8.2mA 0b0001 = 40.5mA 0b0010 = 72.3mA 0b0011 = 103.4mA 0b0100 = 134.1mA 0b0101 = 164.1mA 0b0110 = 193.7mA 0b0111 = 222.7mA 0b1000 = 251.2mA 0b1001 = 279.3mA 0b1010 - 0b1111 = 300mA
MUX_SEL	3:0	Selects the analog channel to connect to AMUX. The AMUX output buffer consumes current unless it is in the 0b0000 state. When measurements are not needed, configure $MUX\_SEL[3:0] = 0b0000$ .	0b0000 = Multiplexer is disabled and AMUX is high-impedance. 0b0001 = CHGIN voltage monitor. 0b0010 = CHGIN current monitor. 0b0011 = BATT voltage monitor. 0b0100 = BATT charge current monitor. Valid only while battery charging is happening ( $CHG = 1$ ). 0b0101 = BATT discharge current monitor normal measurement. 0b0110 = BATT discharge current monitor nulling measurement. 0b0111 = THM voltage monitor. 0b1000 = TBIAS voltage monitor. 0b1001 = AGND voltage monitor (through 100Ω pulldown resistor). 0b1010-0b1111 = SYS voltage monitor.

[CNFG\\_LDO\\_A \(0x30\)](#)

BIT	7	6	5	4	3	2	1	0
Field	ADE_LDO	LDO_VREG[6:0]						
Reset	0b1	OTP						
Access Type	Write, Read	Write, Read						
BITFIELD	BITS	DESCRIPTION	DECODE					
ADE_LDO	7	LDO Active Discharge Resistor Control	0 = Disabled 1 = Enabled					
LDO_VREG	6:0	LDO Target Regulation Voltage ( $V_{LDO-REG}$ ). This 7-bit configuration is a linear transfer function that starts at 0.8V and ends at 3.975V, with 25mV increments.	0x00 = 0.800V 0x01 = 0.825V ... 0x27 = 1.775V 0x28 = 1.800V ... 0x7E = 3.950V 0x7F = 3.975V					

[CNFG\\_LDO\\_B \(0x31\)](#)

BIT		3	2	1	0	
Field		LDO_PM[1:0]		LDO_EN[1:0]		
Reset		0b01		OTP		
Access Type		Write, Read		Write, Read		
BITFIELD	BITS	DESCRIPTION	DECODE			
LDO_PM	3:2	LDO Power Mode Control	0b00 = Forced low-power mode 0b01 = Forced normal mode 0b10 = Pin-controlled, active high (normal mode when PMLDO pin is high) 0b11 = Pin-controlled, active low (normal mode when PMLDO pin is low)			
LDO_EN	1:0	LDO Enable Control	0b00 = LDO is forced disabled 0b01 = LDO is forced enabled 0b10 = LDO enables when nENLDO asserts or when CHGIN is valid. 0b11 = Same as 0b10.			

[CNFG\\_SNK1\\_A \(0x40\)](#)

BIT	7	6	5	4	3	2	1	0
Field	SNK_FS1[1:0]		INV_SNK1	BRT_SNK1[4:0]				
Reset	0b00		0b0	0b00100				
Access Type	Write, Read		Write, Read	Write, Read				

BITFIELD	BITS	DESCRIPTION	DECODE
SNK_FS1	7:6	SNK1 Enable and Full-Scale Range Control	0b00 = Disabled 0b01 = Enabled with 3.2mA full-scale range (0.1mA LSB) 0b10 = Enabled with 6.4mA full-scale range (0.2mA LSB) 0b11 = Enabled with 12.8mA full-scale range (0.4mA LSB)
INV_SNK1	5	SNK1 Invert Control	0 = Positive-Duty Operation. SNK1 is on during the beginning of each period for the programmed duty length. 1 = Negative-Duty Operation. SNK1 is off during the beginning of each period for the programmed duty length.
BRT_SNK1	4:0	SNK1 Current (Brightness) Control  <b>SNK_FS1[1:0] = 0b00</b> <i>don't care</i>  <b>SNK_FS1[1:0] = 0b01</b> 0.1mA–3.2mA in 0.1mA steps  <b>SNK_FS1[1:0] = 0b10</b> 0.2mA–6.4mA in 0.2mA steps  <b>SNK_FS1[1:0] = 0b11</b> 0.4mA–12.8mA in 0.4mA steps	0x00 = 0.1mA/0.2mA/0.4mA 0x01 = 0.2mA/0.4mA/0.8mA ... 0x1F = 3.2mA/6.4mA/12.8mA

**CNFG\_SNK1\_B (0x41)**

BIT	7	6	5	4	3	2	1	0
Field	P_SNK1[3:0]				D_SNK1[3:0]			
Reset	0b0000				0b1111			
Access Type	Write, Read				Write, Read			

BITFIELD	BITS	DESCRIPTION	DECODE
P_SNK1	7:4	SNK1 Period Control	0x0 = 0.5s 0x1 = 1.0s 0x2 = 1.5s 0x3 = 2.0s 0x4 = 2.5s 0x5 = 3.0s 0x6 = 3.5s 0x7 = 4.0s 0x8 = 4.5s 0x9 = 5.0s 0xA = 5.5s 0xB = 6.0s 0xC = 6.5s 0xD = 7.0s 0xE = 7.5s 0xF = 8s

BITFIELD	BITS	DESCRIPTION	DECODE
D_SNK1	3:0	SNK1 Duty Cycle Control	0x0 = 6.25% 0x1 = 12.5% 0x2 = 18.75% 0x3 = 25% 0x4 = 31.25% 0x5 = 37.5% 0x6 = 43.75% 0x7 = 50% 0x8 = 56.25% 0x9 = 62.5% 0xA = 68.75% 0xB = 75% 0xC = 81.25% 0xD = 87.5% 0xE = 93.75% 0xF = 100%

**CNFG\_SNK2\_A (0x42)**

BIT	7	6	5	4	3	2	1	0
Field	SNK_FS2[1:0]		INV_SNK2	BRT_SNK2[4:0]				
Reset	0b00		0b0	0b00100				
Access Type	Write, Read		Write, Read	Write, Read				

BITFIELD	BITS	DESCRIPTION	DECODE
SNK_FS2	7:6	SNK2 Enable and Full-Scale Range Control	0b00 = Disabled 0b01 = Enabled with 3.2mA full-scale range (0.1mA LSB) 0b10 = Enabled with 6.4mA full-scale range (0.2mA LSB) 0b11 = Enabled with 12.8mA full-scale range (0.4mA LSB)
INV_SNK2	5	SNK2 Invert Control	0 = Positive-Duty Operation. SNK2 is on during the beginning of each period for the programmed duty length. 1 = Negative-Duty Operation. SNK2 is off during the beginning of each period for the programmed duty length.
BRT_SNK2	4:0	SNK2 Current (Brightness) Control <b>SNK_FS2[1:0] = 0b00</b> <i>don't care</i> <b>SNK_FS2[1:0] = 0b01</b> 0.1mA–3.2mA in 0.1mA steps <b>SNK_FS2[1:0] = 0b10</b> 0.2mA–6.4mA in 0.2mA steps <b>SNK_FS2[1:0] = 0b11</b> 0.4mA–12.8mA in 0.4mA steps	0x00 = 0.1mA/0.2mA/0.4mA 0x01 = 0.2mA/0.4mA/0.8mA ... 0x1F = 3.2mA/6.4mA/12.8mA

CNFG\_SNK2\_B (0x43)

BIT	7	6	5	4	3	2	1	0
Field	P_SNK2[3:0]				D_SNK2[3:0]			
Reset	0b0000				0b1111			
Access Type	Write, Read				Write, Read			

BITFIELD	BITS	DESCRIPTION	DECODE
P_SNK2	7:4	SNK2 Period Control	0x0 = 0.5s 0x1 = 1.0s 0x2 = 1.5s 0x3 = 2.0s 0x4 = 2.5s 0x5 = 3.0s 0x6 = 3.5s 0x7 = 4.0s 0x8 = 4.5s 0x9 = 5.0s 0xA = 5.5s 0xB = 6.0s 0xC = 6.5s 0xD = 7.0s 0xE = 7.5s 0xF = 8s
D_SNK2	3:0	SNK2 Duty Cycle Control	0x0 = 6.25% 0x1 = 12.5% 0x2 = 18.75% 0x3 = 25% 0x4 = 31.25% 0x5 = 37.5% 0x6 = 43.75% 0x7 = 50% 0x8 = 56.25% 0x9 = 62.5% 0xA = 68.75% 0xB = 75% 0xC = 81.25% 0xD = 87.5% 0xE = 93.75% 0xF = 100%

CNFG\_SNK\_TOP (0x44)

BIT	7	6	5	4	3	2	1	0
Field	-	-	-	-	-	-	CLK_64_S	EN_SNK_MSTR
Reset	-	-	-	-	-	-	0b0	0b0
Access Type	-	-	-	-	-	-	Read Only	Write, Read

BITFIELD	BITS	DESCRIPTION	DECODE
RSVD	72		

<b>BITFIELD</b>	<b>BITS</b>	<b>DESCRIPTION</b>	<b>DECODE</b>
CLK_64_S	1	64Hz Clock Mirror. CLK_64_S is internally driven by the same clock that drives the current sink PWM logic. This signal has a 10% duty cycle. Allows software to align LED blink patterns between SNK1 and SNK2.	0 = Root clock is low. 1 = Root clock is high.
EN_SNK_MS TR	0	Master Sink Enable Bit	0 = Current sinks disabled. 1 = Current sinks enabled.



Typical Application Circuits (continued)

Battery Charger using LDO Software Enable

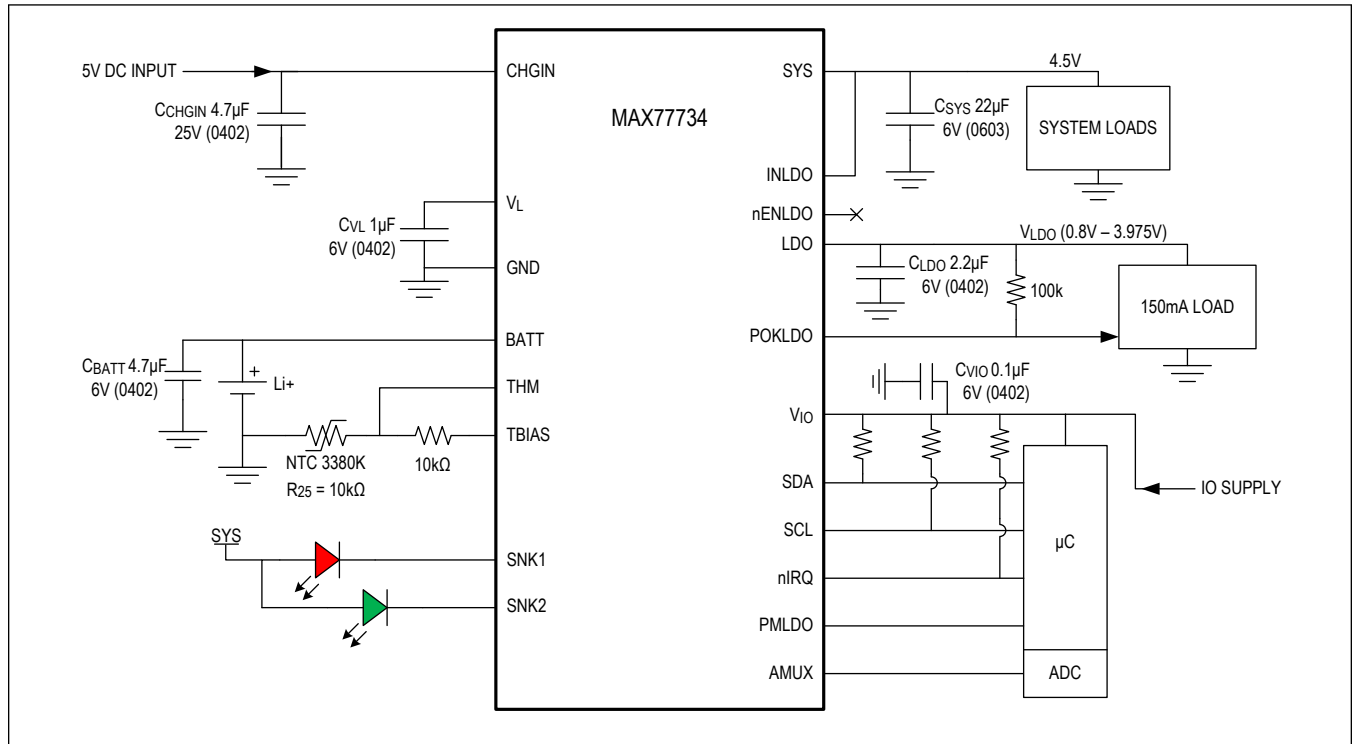

Ordering Information

PART NUMBER	TEMP RANGE	PIN-PACKAGE	FACTORY OPTIONS
MAX77734ENP+*	-40°C to +85°C	20 WLP	Engineering samples with custom options
MAX77734AENP+T**	-40°C to +85°C	20 WLP	A
MAX77734BENP+T	-40°C to +85°C	20 WLP	B
MAX77734CENP+T	-40°C to +85°C	20 WLP	C
MAX77734GENP+T	-40°C to +85°C	20 WLP	G
MAX77734QENP+T	-40°C to +85°C	20 WLP	Q
MAX77734MENP+T	-40°C to +85°C	20 WLP	M

+ Denotes a lead(Pb)-free/RoHS-compliant package.

T = Tape and reel.

\* Custom samples only. Not for production or stock. [Contact factory](#) for information.

\*\* Future product—[Contact factory](#) for availability.

## Revision History

REVISION NUMBER	REVISION DATE	DESCRIPTION	PAGES CHANGED
0	10/18	Initial release	—
1	9/17	Updated <i>General Description</i> and <i>Applications</i> sections, replaced Simplified Application Circuit, Figure 5, Figure 8, Figure 13, and Figure 15, updated <i>Typical Operating Characteristics</i> , Table 1 changed to Table 3, Table 3 changed to Table 1, corrected symbiology	1, 15, 17, 20, 21, 25–28, 30–33, 38, 39, 45, 47, 73, 74
2	5/18	Updated <i>Electrical Characteristics</i> tables, updated TOC6, replaced Table 10, updated Figure 13, added new section called <i>PCB Layout Guidelines</i> , updated CNFG_CHG_I (0x28) in <i>Register Map</i> , updated <i>Ordering Information</i> table	1, 3, 7, 9, 19, 20, 26, 29, 30, 33, 42, 45–47, 66, 73, 74
3	7/18	Updated Table 1, added new part number to Table 6, added new part number to <i>Ordering Information</i> table	1, 26, 33, 74, 75
4	11/18	Updated <i>Electrical Characteristics</i> table, updated descriptions in <i>Register Map</i> section, added MAX77734Q to the <i>Ordering Information</i> table	1, 10, 33, 40, 53, 75
5	7/20	Updated <i>Benefits and Features</i> , <i>Shutdown (Bias Off) State</i> section, Figure 7, <i>Battery Temperature Fault State</i> section, and descriptions in <i>Register Map</i> section	1, 29, 36, 38, 59, 69, 71
6	4/23	Updated <i>General Description</i> , <i>Electrical Characteristics—Smart Power Selector Charger</i> , TOC 12, Table 6, <i>Register Details</i> , added <i>Power Mode</i> section, added MAX77734M to the <i>Ordering Information</i> table	1, 11, 20, 30, 32, 33, 59, 71

## Looking for pricing, stock, or lifecycle information?

Click below to explore more details on WIN SOURCE:

- ⊖ [View MAX77734BENP+T on WIN SOURCE](#)
- ⊖ [Maxim Integrated Information](#)

## Optimize Your Supply Chain with WIN SOURCE Solutions

- ✓ Global Sourcing Solution
- ✓ Obsolete Management
- ✓ Cost Control Management
- ✓ Shortage Management
- ✓ Alternative Solution
- ✓ Excess Inventory Management