

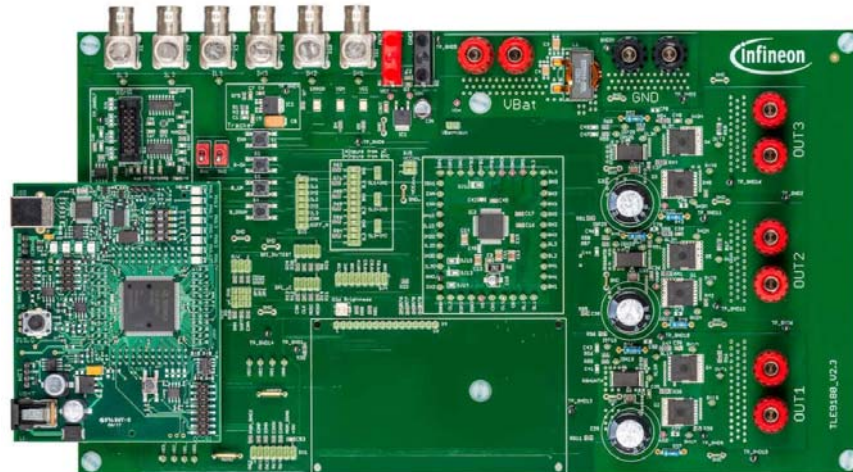

**THE DATASHEET OF
EVAL_TLE9180D-31QK**





EVAL_TLE9180D-31QK

This evaluation board has the purpose to quickly get familiar with the gate driver IC **TLE9180D-31QK** and evaluate the functions. The board can be operated at an input voltage range from 12 V up to 48 V DC.

Summary of Features

- Main board with the 3-phase gate driver IC, MOSFET power stage and auxiliary components
- Pre-flashed microcontroller board using the Infineon XC2785X-104F to establish a communication link between the driver IC and the PC
- USB cable to connect the microcontroller to a PC
- Graphical user interface for register easy access to the driver IC (available for Microsoft Windows only)

Potential Applications

- 48 V motor drives
- Cooling fans
- Water pump
- Oil Pump
- HVAC compressor
- Commercial and agricultural vehicles

Access to complete technical documentation including application notes and design tools:

1. Please register under myinfineon.com with your company e-mail address
2. Send login name to: motordriver@infineon.com
3. Automated update service will be provided for new documents once you are registered
4. Full registration process might take up to 24h to be completed (due to different time zones)

Diagrams

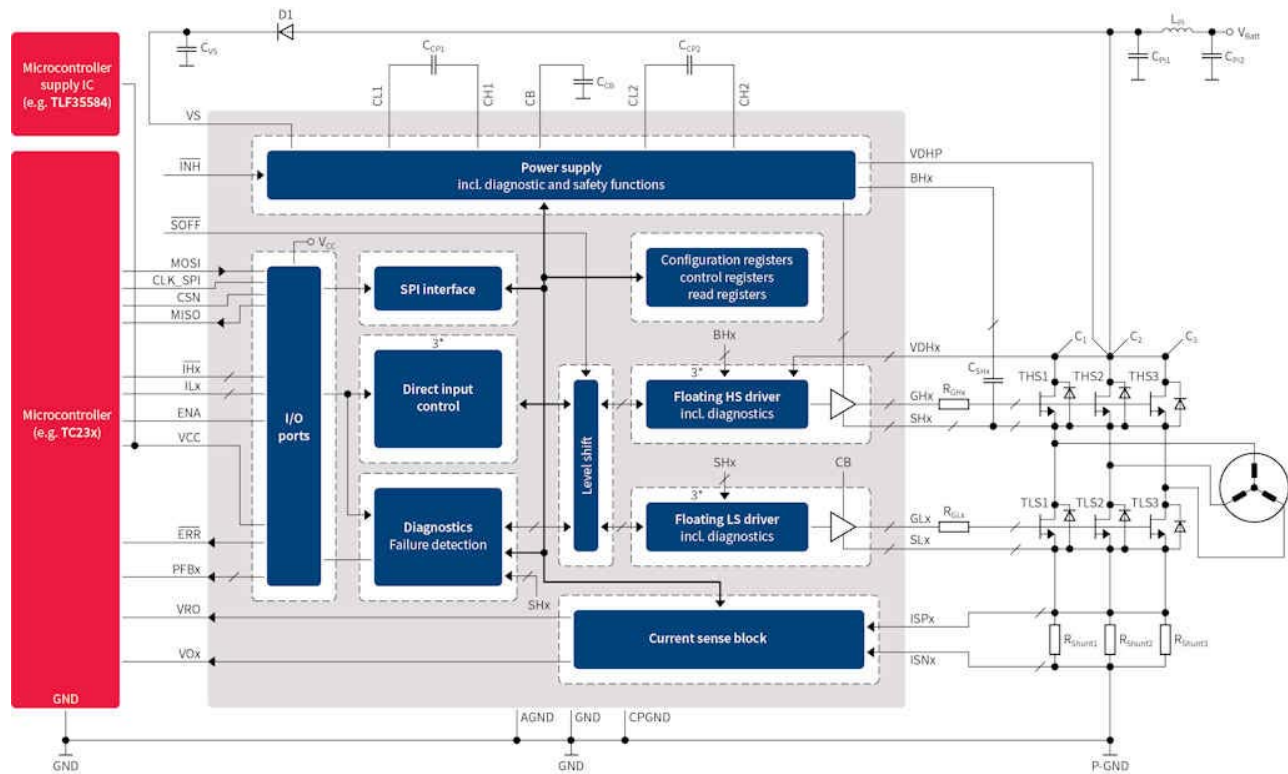

Parametrics

Parametrics	EVAL_TLE9180D-31QK
Family	3-phase gate driver IC ; Microcontroller
Input Type	DC
Output Voltage min max	12.0 V 48.0 V
Product Description	Evaluation board for TLE9180D-31QK to quickly get familiar with the gate driver IC. The board includes power MOSFETs and a microcontroller on a daughter card. The board comes together with a GUI to easily establish the SPI communication and get it running.
Qualification	Automotive
Supply Voltage min max	12.0 V 48.0 V
Target Application	Automotive ; Motor Control & Drives
Topology	3-Phase Inverter
Type	Evaluation Board
Parametrics	EVAL_TLE9180D-31QK

Order

Sales Product Name	EVAL_TLE9180D-31QK
OPN	EVALTLE9180D31QKTOBO1
Product Status	active and preferred
Package name	--

Sales Product Name	EVAL_TLE9180D-31QK
Order online	
Completely lead free	
Halogen free	
RoHS compliant	no
Packing Size	1
Packing Type	CONTAINER
Moisture Level	
Moisture Packing	NON DRY

Looking for pricing, stock, or lifecycle information?

Click below to explore more details on WIN SOURCE:

 [View EVAL_TLE9180D-31QK on WIN SOURCE](#)

 [Infineon Technologies](#) Information

Optimize Your Supply Chain with WIN SOURCE Solutions

-  Global Sourcing Solution
-  Obsolete Management
-  Cost Control Management
-  Shortage Management
-  Alternative Solution
-  Excess Inventory Management