



THE DATASHEET OF
0845-2R1T-E4



THE INFORMATION CONTAINED HEREIN IS CONSIDERED "PROPRIETARY" TO BEL FUSE INC. AND SHALL NOT BE COPIED, REPRODUCED OR DISCLOSED WITHOUT THE WRITTEN APPROVAL OF BEL FUSE INC.

LED1 POLARITY			LED2 POLARITY		
PIN 27	PIN 28	COLOR	PIN 29	PIN 30	COLOR
-	+	GREEN	+	-	YELLOW
			-	+	GREEN

RoHS



ELECTRICAL CHARACTERISTICS @ 25°C

URNS RATIO	
TP1	1CT : 1CT ±2%
TP2	1CT : 1CT ±2%
TP3	1CT : 1CT ±2%
TP4	1CT : 1CT ±2%
OCCL @ 100kHz,100mVRMS	350 μH MIN.
8mA DC BIAS	
INS. LOSS	
100KHz TO 100MHz	-1.1 dB MAX
RET. LOSS (MIN)	
1MHz-30MHz	-18 dB
30MHz-60MHz	-16 dB
60MHz-80MHz	-14 dB
80MHz-100MHz	-12 dB
CM TO CM REJ	
100kHz - 100MHz	-25 dB TYP
CROSS TALK	
1MHz - 60MHz	-35 dB TYP
60MHz - 100MHz	-25 dB TYP
HIPOT (Isolation Voltage):	
	1500 Vrms
100% OF PRODUCTION TESTED TO COMPLY WITH IEEE 802.3 ISOLATION REQUIREMENTS.	
INTERWINDING CAPACITANCE	
PER CHANNEL (PRI. TO SEC.)	50pF Max @ 1MHz
DC RESISTANCE	
(21-15)=(16-23)=(24-18)=(19-26)	1.2 ohms Max
(RJ1-RJ2)=(RJ3-RJ6)=(RJ4-RJ5)=(RJ7-RJ8)	1.2 ohms Max
LED 1	
VF (FORWARD VOLTAGE)	IF=20mA GREEN 2.2V TYP.
λD (DOMINANT WAVELENGTH)	IF=20mA GREEN 570nm TYP.
LED 2	
VF (FORWARD VOLTAGE)	IF=20mA GREEN 2.2V TYP.
λD (DOMINANT WAVELENGTH)	IF=20mA GREEN 570nm TYP.
	IF=20mA GREEN 570nm TYP.
	YELLOW 2.1V TYP.
	YELLOW 590nm TYP.
OPERATING TEMPERATURE: 0°C TO +70°C.	

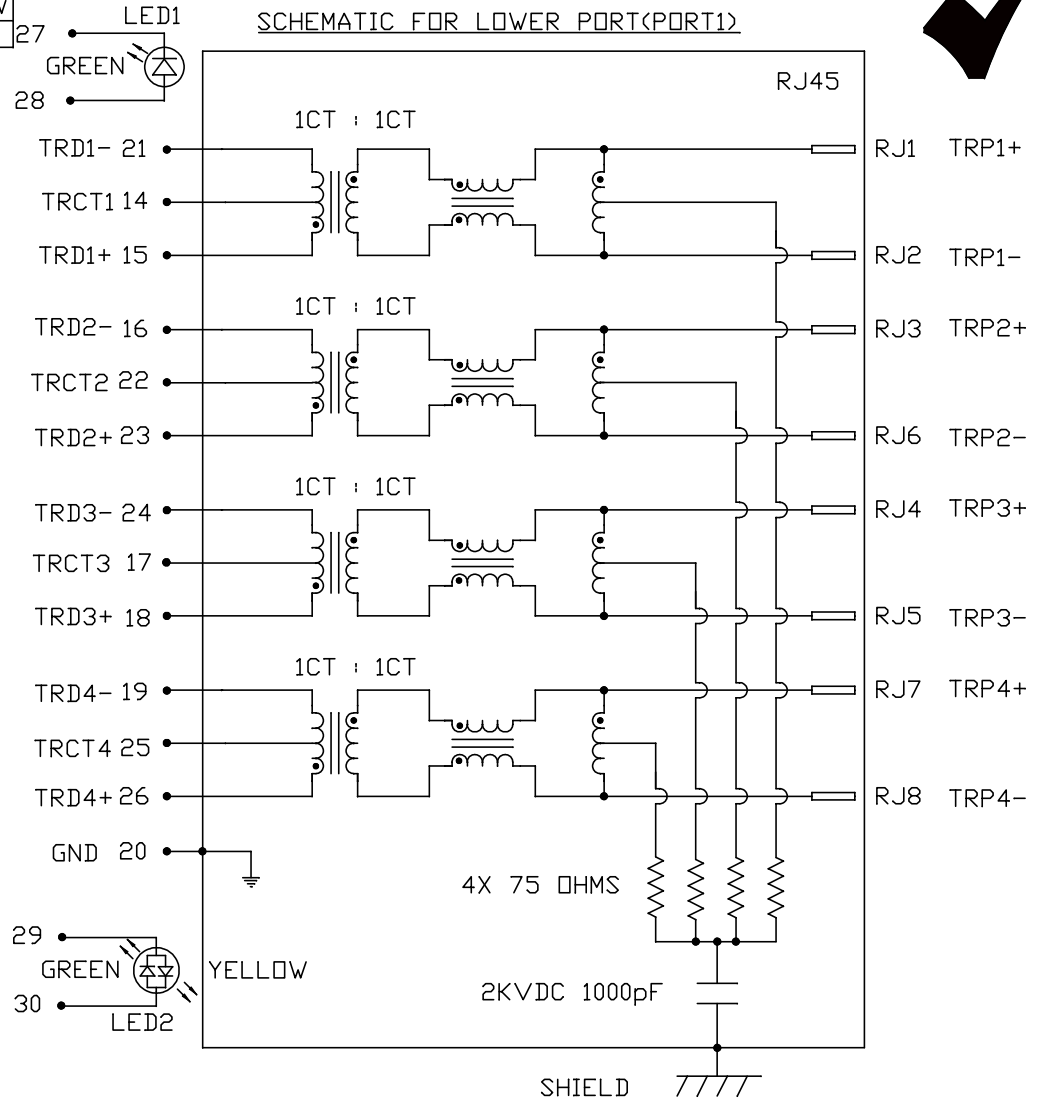

ORIGINATED BY
CHOW WANCHUNG
DATE 2017-02-25

DRAWN BY
XIE YIMING
DATE 2017-02-25

TITLE
2X1 gigabit MagJack®
(WITH LED)
PATENTED

PART NO. / DRAWING NO.
0845-2R1T-E4

FILE NAME
0845-2R1T-E4_H.DWG

STANDARD DIM. TOL. IN INCH
.X
.XX
.XXX

[] METRIC DIM. AS REF.
UNIT : INCH [mm]
SCALE : N/A
SIZE : A4

REV. : H PAGE : 2



THE INFORMATION CONTAINED HEREIN IS CONSIDERED 'PROPRIETARY' TO BEL FUSE INC. AND SHALL NOT BE COPIED, REPRODUCED OR DISCLOSED WITHOUT THE WRITTEN APPROVAL OF BEL FUSE INC.

LED3 POLARITY			LED4 POLARITY		
PIN 31	PIN 32	COLOR	PIN 33	PIN 34	COLOR
-	+	GREEN	+	-	YELLOW
			-	+	GREEN

RoHS



ELECTRICAL CHARACTERISTICS @ 25°C

TURNS RATIO

TP1	1CT : 1CT ±2%
TP2	1CT : 1CT ±2%
TP3	1CT : 1CT ±2%
TP4	1CT : 1CT ±2%

QCL @ 100kHz,100mVRMS

8mA DC BIAS 350 µH MIN.

INS. LOSS

100kHz TO 100MHZ -1.1 dB MAX

RET. LOSS (MIN)

1MHz-30MHz -18 dB

30MHz-60MHz -16 dB

60MHz-80MHz -14 dB

80MHz-100MHz -12 dB

CM TO CM REJ

100kHz - 100MHz -25 dB TYP

CROSS TALK

1MHz - 60MHz -35 dB TYP

60MHz - 100MHz -25 dB TYP

HIPOT (Isolation Voltage):

1500 Vrms

100% OF PRODUCTION TESTED TO COMPLY WITH

IEEE 802.3 ISOLATION REQUIREMENTS.

INTERWINDING CAPACITANCE

PER CHANNEL (PRI. TO SEC.) 50pF Max @ 1MHz

DC RESISTANCE

(13-6)=(5-11)=(10-3)=(2-8) 1.2 ohms Max

(RJ1-RJ2)=(RJ3-RJ6)=(RJ4-RJ5)=(RJ7-RJ8) 1.2 ohms Max

LED 3 (Super bright)

VF (FORWARD VOLTAGE) IF=20mA GREEN 2.2V TYP.

λD (DOMINANT WAVELENGTH) IF=20mA GREEN 570nm TYP.

LED 4 (Super bright)

VF (FORWARD VOLTAGE) IF=20mA GREEN 2.2V TYP.

λD (DOMINANT WAVELENGTH) IF=20mA GREEN 570nm TYP.

IF=20mA GREEN 570nm TYP.

IF=20mA GREEN 570nm TYP.

IF=20mA GREEN 570nm TYP.

IF=20mA GREEN 570nm TYP.

OPERATING TEMPERATURE: 0°C TO +70°C.

ORIGINATED BY CHOW WANCHUNG	TITLE 2X1 gigabit MagJack® (WITH LED) PATENTED
DATE 2017-02-25	
DRAWN BY XIE YIMING	
DATE 2017-02-25	

PART NO. / DRAWING NO. 0845-2R1T-E4	STANDARD DIM. TOL. IN INCH	[] METRIC DIM. AS REF.
FILE NAME 0845-2R1T-E4_H.DWG	.X .XX .XXX	UNIT : INCH [mm] SCALE : N/A SIZE : A4

REV. : H	PAGE : 3
-----------------	-----------------

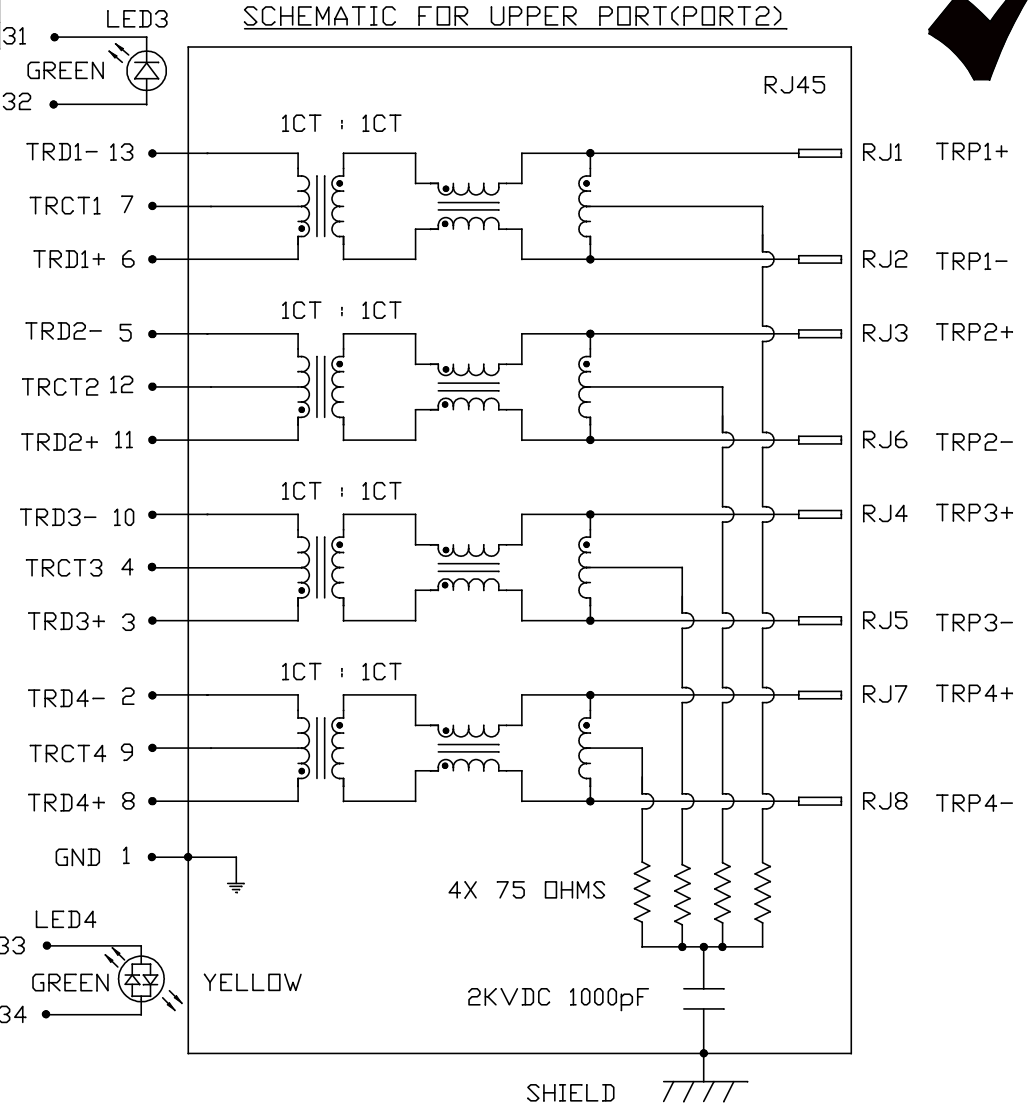

THE INFORMATION CONTAINED HEREIN IS CONSIDERED "PROPRIETARY" TO BEL FUSE INC. AND SHALL NOT BE COPIED, REPRODUCED OR DISCLOSED WITHOUT THE WRITTEN APPROVAL OF BEL FUSE INC.

RoHS

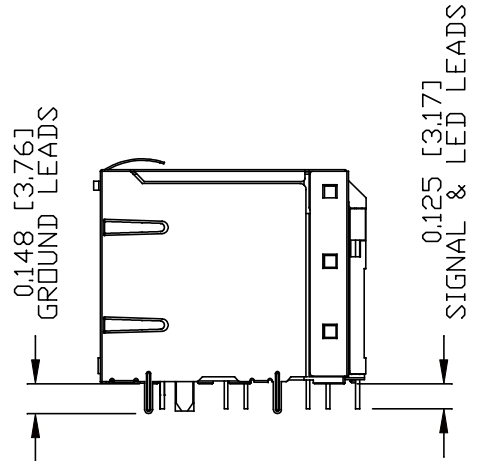
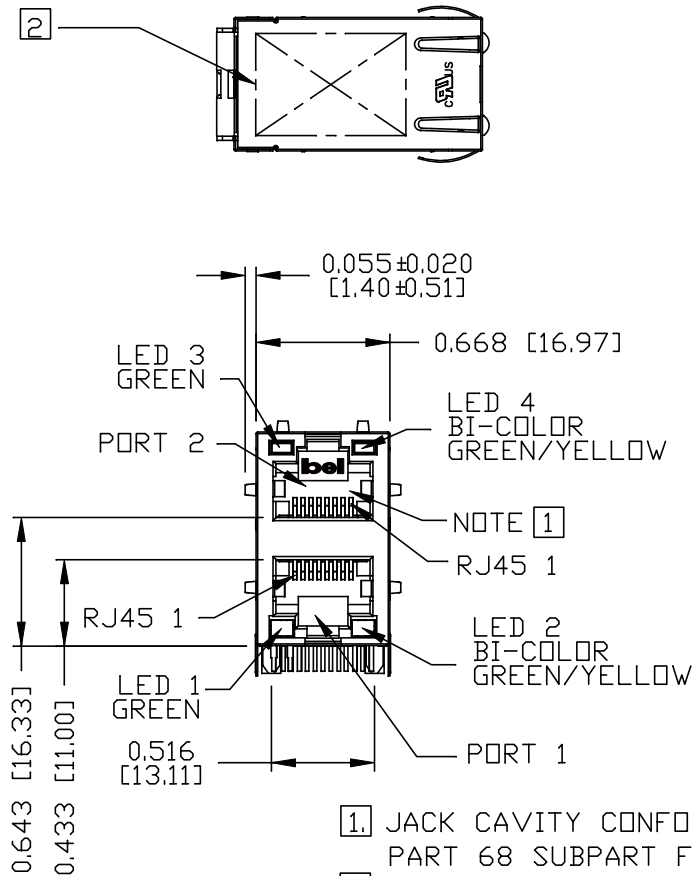
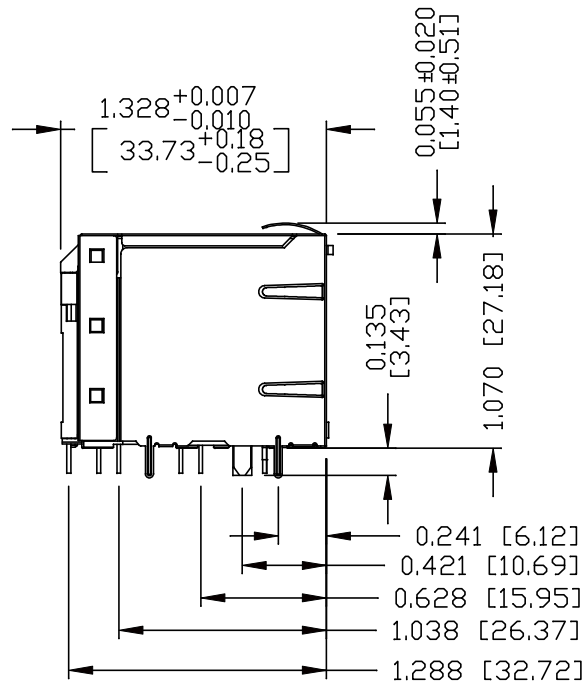

NOTES:

PLASTIC HOUSING: THERMOPLASTIC PBT, BLACK
 FLAMMABILITY RATING UL 94V-0
 CONTACT PLATING: 50 MICRO-INCH HARD GOLD PLATING OR EQUIVALENT,
 30 MICRO-INCH MIN NICKEL UNDERPLATE.
 OUTPUT PINS: TIN-COATED COPPER WIRE, DIA 0.018 INCH.
 100 MICRO-INCH MIN MATTE TIN.
 PINS ARE SOLDER DIPPED.
 METAL SHIELD: NICKEL PLATED ON COPPER ALLOY.
 (ALL GROUND LEADS ARE SOLDER DIPPED)

1. JACK CAVITY CONFORMS TO FCC RULES AND REGULATIONS, PART 68 SUBPART F.
2. MARK PART WITH MFG LOGO, MFG NAME, PART NUMBER, DATE CODE AND PATENTED.
3. THE PRODUCT IS RoHS COMPLIANCE.
4. THE PRODUCT IS PATENTED. THE PATENT NUMBER IS U.S. PAT. 6,840,817
5. THE PRODUCT IS RECOMMENDED FOR WAVE SOLDERING PROCESS, PEAK TEMPERATURE 260°C MAX. AND 10 SECONDS MAX..

UL RECOGNIZED - FILE #E196366 AND E169987.

ORIGINATED BY
 ANTON LIAO
 DATE 2017-02-25
 DRAWN BY
 LIU DONGJUN
 DATE 2017-02-25

TITLE
 2X1 gigabit MagJack®
 (WITH LED)
 PATENTED

PART NO. / DRAWING NO.
 0845-2R1T-E4
 FILE NAME
 0845-2R1T-E4_H.DWG

STANDARD DIM. TOL. IN INCH	[] METRIC DIM. AS REF.
.X	UNIT : INCH [mm]
.XX	SCALE : N/A
.XXX	±0.010 SIZE : A4

REV. : H PAGE : 4



THE INFORMATION CONTAINED HEREIN IS CONSIDERED "PROPRIETARY" TO BEL FUSE INC. AND SHALL NOT BE COPIED, REPRODUCED OR DISCLOSED WITHOUT THE WRITTEN APPROVAL OF BEL FUSE INC.

RoHS



LED CONFIGURATION

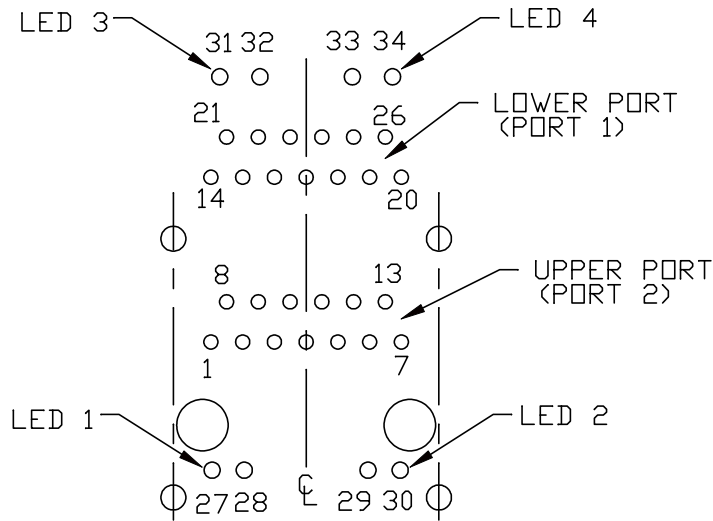

PIN-OUT INFORMATION
 (COMPONENT SIDE VIEW)

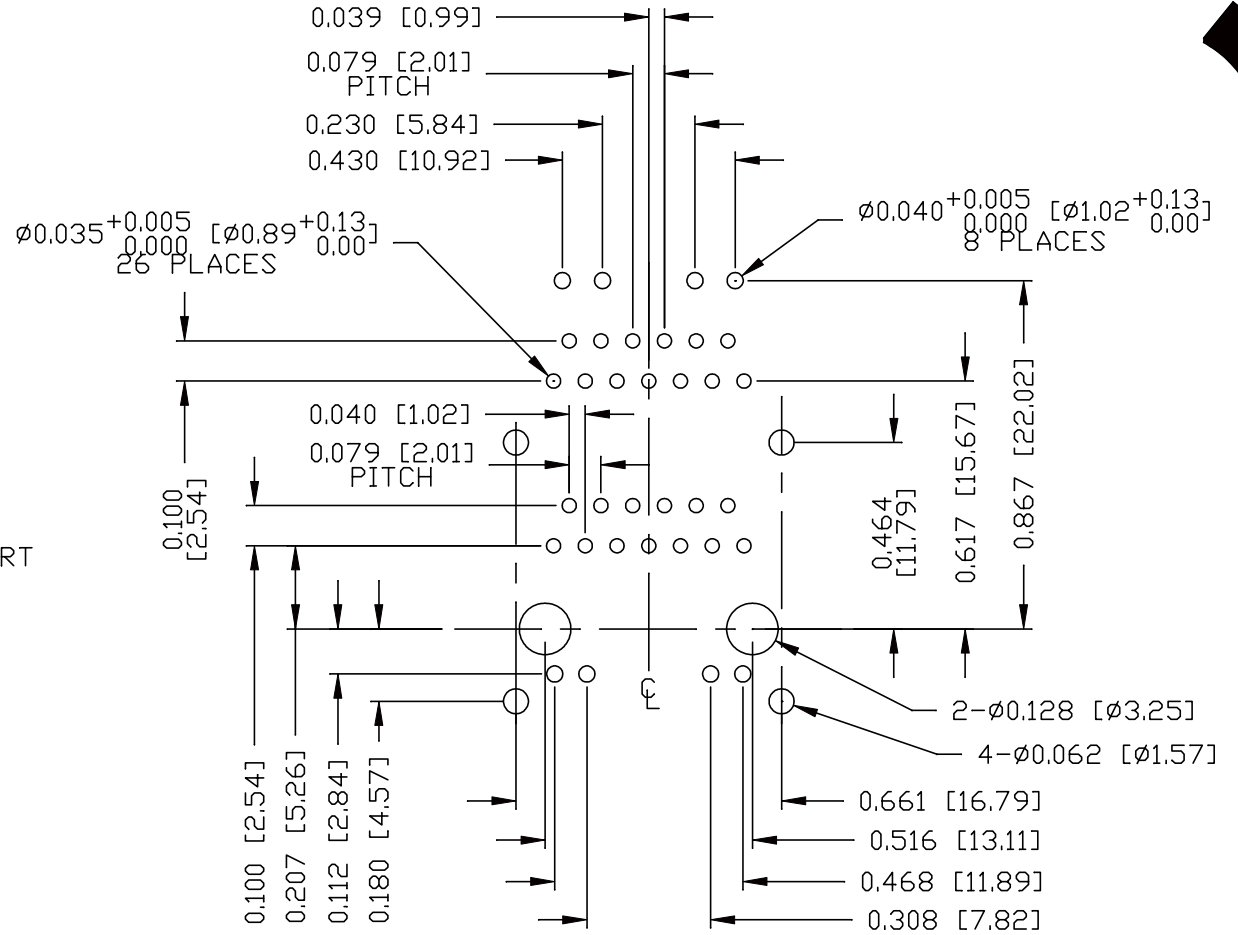

SUGGESTED FOOTPRINT
 (COMPONENT SIDE VIEW)

REV. : H PAGE : 5

ORIGINATED BY
 ANTON LIAD
 DATE 2017-02-25
 DRAWN BY
 LIU DONGJUN
 DATE 2017-02-25

TITLE
 2X1 gigabit MagJack®
 (with LED)
 PATENTED

PART NO. / DRAWING NO.
 0845-2R1T-E4
 FILE NAME
 0845-2R1T-E4_H.DWG

STANDARD DIM. TOL. IN INCH		[] METRIC DIM. AS REF.
.X		UNIT : INCH [mm]
.XX		SCALE : N/A
.XXX	±0.004	SIZE : A4



THE INFORMATION CONTAINED HEREIN IS CONSIDERED "PROPRIETARY" TO BEL FUSE INC. AND SHALL NOT BE COPIED, REPRODUCED OR DISCLOSED WITHOUT THE WRITTEN APPROVAL OF BEL FUSE INC.

RoHS

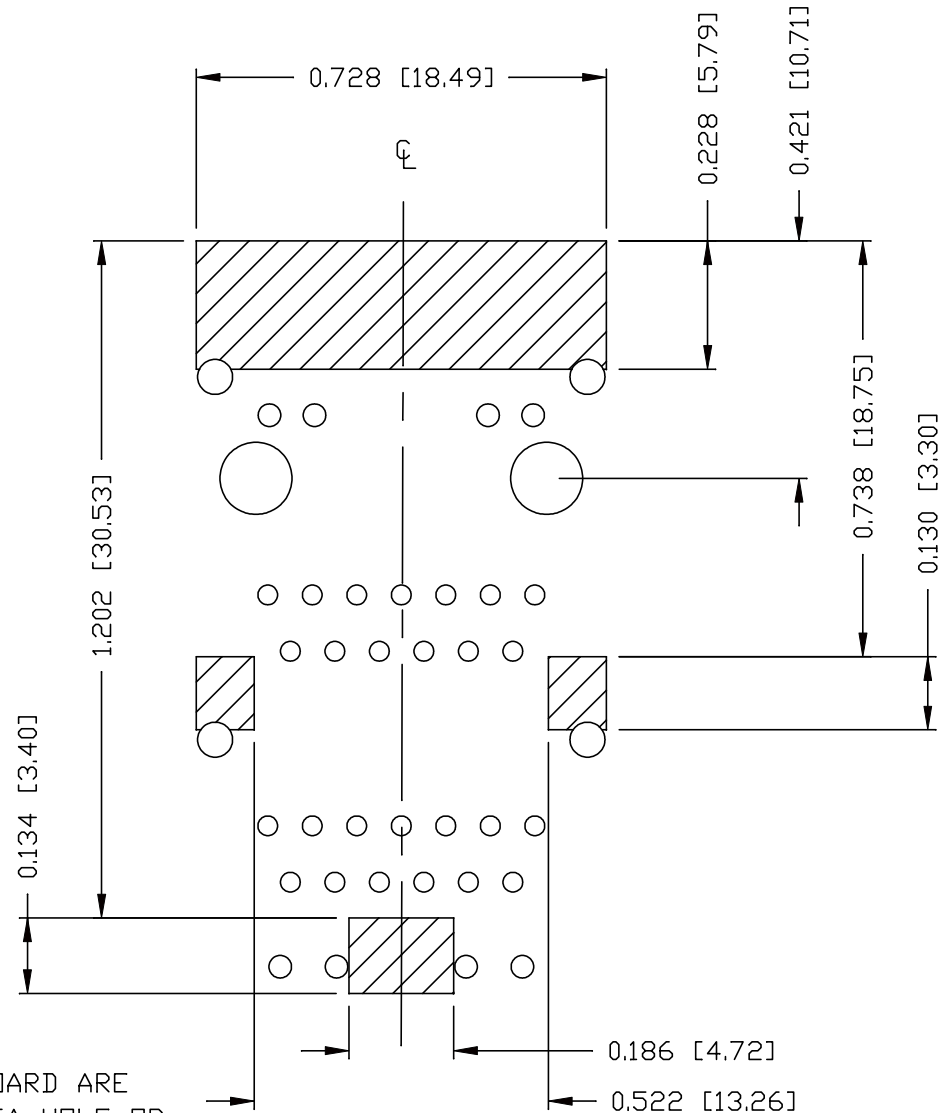

NOTES

THE SHADED AREA ON THE CUSTOMER BOARD ARE RECOMMENDED TO BE CLEAR OFF ANY VIA HOLE OR COMPONENT PAD.

ORIGINATED BY
ANTON LIAO
DATE 2017-02-25
DRAWN BY
LIU DONGJUN
DATE 2017-02-25

TITLE
2X1 gigabit MagJack®
(WITH LED)
PATENTED

PART NO. / DRAWING NO.
0845-2R1T-E4
FILE NAME
0845-2R1T-E4_H.DWG

STANDARD DIM. TOL. IN INCH	[] METRIC DIM. AS REF.
.X	UNIT : INCH [mm]
.XX	SCALE : N/A
.XXX	±0.004
	SIZE : A4

REV. : H PAGE : 6



THE INFORMATION CONTAINED HEREIN IS CONSIDERED "PROPRIETARY" TO BEL FUSE INC. AND SHALL NOT BE COPIED, REPRODUCED OR DISCLOSED WITHOUT THE WRITTEN APPROVAL OF BEL FUSE INC.

RoHS

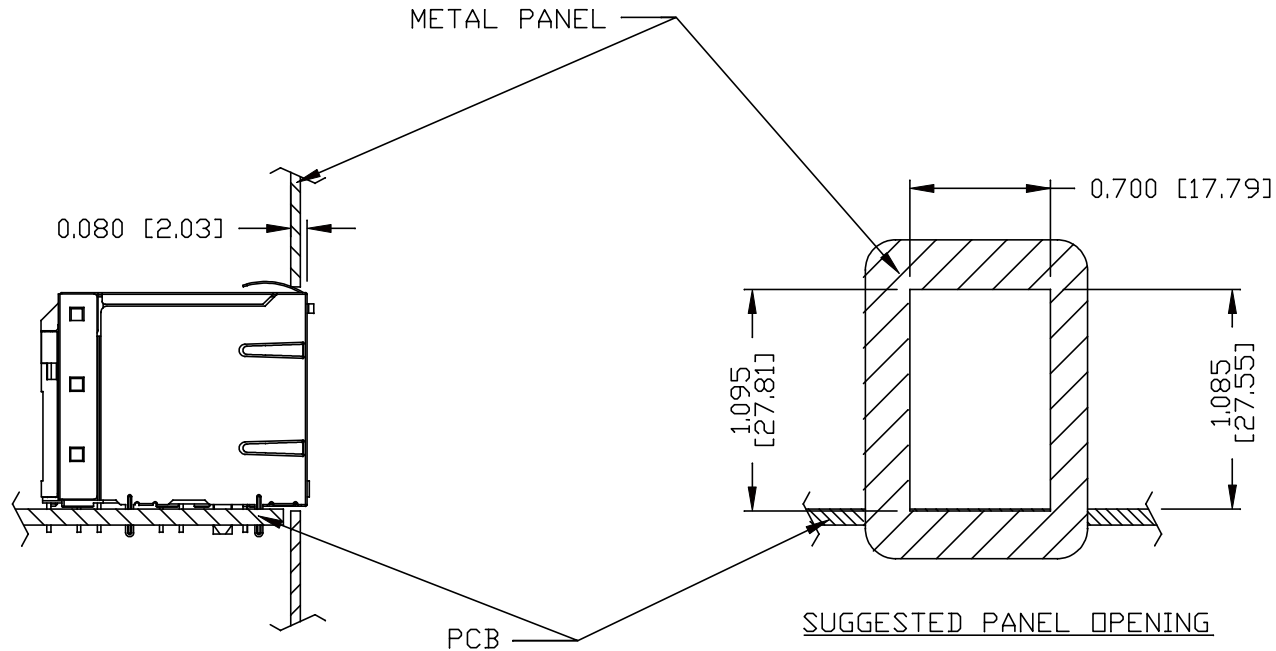

NOTE:

THE DISTANCE OF PANEL INSIDE SURFACE RELATIVE TO FRONT SURFACE OF PART IS ONLY A SUGGESTION. IN CASE THIS DISTANCE IS DIFFERENT, THE REQUIRED PANEL OPENING DIMENSIONS CHANGE ACCORDINGLY.

PACKING INFORMATION

PACKING TRAY: 0200-9999-H5 (TOP)
0200-9999-H6 (BOTTOM)

PACKING QUANTITY: 40 PCS FINISHED GOODS PER TRAY
6 TRAYS (240 PCS FINISHED GOODS) PER CARTON BOX.

NOTE: CARDBOARD ARE PLACED BETWEEN LAYERS OF PACKING TRAY INSIDE CARTON BOX.
(INCLUDE THE UPPERMOST AND LOWEREST TRAY)

REV. : H PAGE : 7

ORIGINATED BY
ANTON LIAO
DATE 2017-02-25

DRAWN BY
LIU DONGJUN
DATE 2017-02-25

TITLE
2X1 gigabit MagJack®
(WITH LED)
PATENTED

PART NO. / DRAWING NO.
0845-2R1T-E4

FILE NAME
0845-2R1T-E4_H.DWG

STANDARD DIM. TOL. IN INCH	[] METRIC DIM. AS REF.
.X	UNIT : INCH [mm]
.XX	SCALE : N/A
.XXX	±0.004
	SIZE : A4



Looking for pricing, stock, or lifecycle information?

Click below to explore more details on WIN SOURCE:

 [View 0845-2R1T-E4 on WIN SOURCE](#)

 [Bel Fuse Inc. Information](#)

Optimize Your Supply Chain with WIN SOURCE Solutions

-  Global Sourcing Solution
-  Obsolete Management
-  Cost Control Management
-  Shortage Management
-  Alternative Solution
-  Excess Inventory Management